

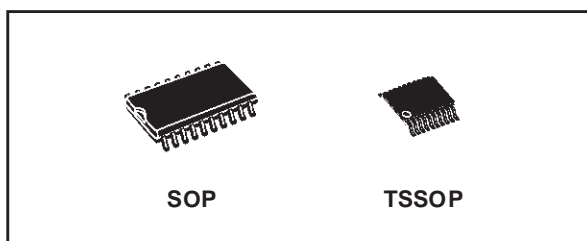

74LVQ541

OCTAL BUS BUFFER WITH 3 STATE OUTPUTS (NON INVERTED)

- HIGH SPEED:
 $t_{PD} = 5.8 \text{ ns (TYP.)}$ at $V_{CC} = 3.3 \text{ V}$
- COMPATIBLE WITH TTL OUTPUTS
- LOW POWER DISSIPATION:
 $I_{CC} = 4 \mu\text{A (MAX.)}$ at $T_A = 25^\circ\text{C}$
- LOW NOISE:
 $V_{OLP} = 0.4\text{V (TYP.)}$ at $V_{CC} = 3.3\text{V}$
- 75Ω TRANSMISSION LINE DRIVING CAPABILITY
- SYMMETRICAL OUTPUT IMPEDANCE:
 $|I_{OH}| = I_{OL} = 12\text{mA (MIN.)}$ at $V_{CC} = 3.0 \text{ V}$
- PCI BUS LEVELS GUARANTEED AT 24 mA
- BALANCED PROPAGATION DELAYS:
 $t_{PLH} \cong t_{PHL}$
- OPERATING VOLTAGE RANGE:
 $V_{CC(OPR)} = 2\text{V to } 3.6\text{V (1.2V Data Retention)}$
- PIN AND FUNCTION COMPATIBLE WITH 74 SERIES 541
- IMPROVED LATCH-UP IMMUNITY



ORDER CODES

PACKAGE	TUBE	T & R
SOP	74LVQ541M	74LVQ541MTR
TSSOP		74LVQ541TTR

DESCRIPTION

The 74LVQ541 is a low voltage CMOS OCTAL BUS BUFFER with 3 STATE OUTPUTS NON INVERTED fabricated with sub-micron silicon gate and double-layer metal wiring C²MOS technology. It is ideal for low power and low noise 3.3V applications.

The 3-STATE control gate operates as two input and such that if either $\overline{G1}$ and $\overline{G2}$ are high, all eight outputs are in the high impedance state. In order to enhance PC board layout, the 74LVQ541 offers a pinout having inputs and outputs on opposite side of the package.

All inputs and outputs are equipped with protection circuits against static discharge, giving them 2KV ESD immunity and transient excess voltage.

PIN CONNECTION AND IEC LOGIC SYMBOLS

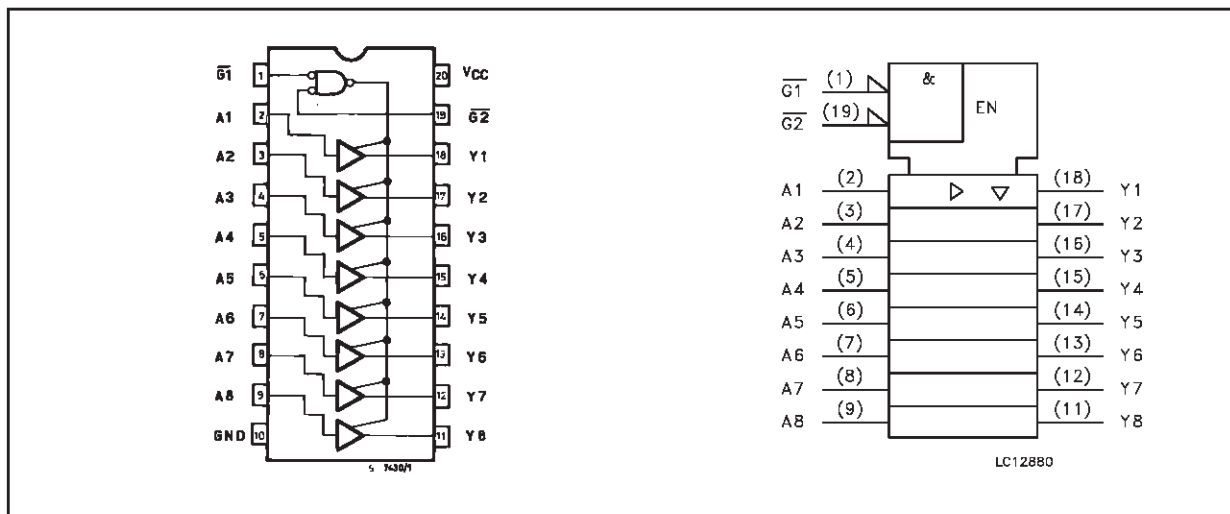

INPUT AND OUTPUT EQUIVALENT CIRCUIT

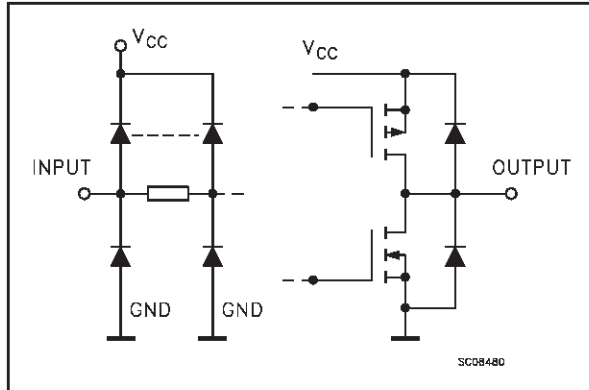

PIN DESCRIPTION

PIN No	SYMBOL	NAME AND FUNCTION
1, 19	G1, G2	Output Enable Inputs
2, 3, 4, 5, 6, 7, 8, 9	A1 to A8	Data Inputs
18, 17, 16, 15, 14, 13, 12, 11	Y1 to Y8	Data Outputs
10	GND	Ground (0V)
20	V _{CC}	Positive Supply Voltage

TRUTH TABLE

INPUTS			OUTPUT
$\overline{G1}$	$\overline{G2}$	A _n	Y _n
H	X	X	Z
X	H	X	Z
L	L	L	L
L	L	H	H

X : Don't Care
Z : High Impedance

ABSOLUTE MAXIMUM RATINGS

Symbol	Parameter	Value	Unit
V _{CC}	Supply Voltage	-0.5 to +7	V
V _I	DC Input Voltage	-0.5 to V _{CC} + 0.5	V
V _O	DC Output Voltage	-0.5 to V _{CC} + 0.5	V
I _{IK}	DC Input Diode Current	± 20	mA
I _{OK}	DC Output Diode Current	± 20	mA
I _O	DC Output Current	± 50	mA
I _{CC} or I _{GND}	DC V _{CC} or Ground Current	± 400	mA
T _{stg}	Storage Temperature	-65 to +150	°C
T _L	Lead Temperature (10 sec)	300	°C

Absolute Maximum Ratings are those values beyond which damage to the device may occur. Functional operation under these conditions is not implied

RECOMMENDED OPERATING CONDITIONS

Symbol	Parameter	Value	Unit
V _{CC}	Supply Voltage (note 1)	2 to 3.6	V
V _I	Input Voltage	0 to V _{CC}	V
V _O	Output Voltage	0 to V _{CC}	V
T _{op}	Operating Temperature	-55 to 125	°C
dt/dv	Input Rise and Fall Time V _{CC} = 3.0V (note 2)	0 to 10	ns/V

1) Truth Table guaranteed: 1.2V to 3.6V

2) V_{IN} from 0.8V to 2V

DC SPECIFICATIONS

Symbol	Parameter	Test Condition		Value						Unit	
		V _{CC} (V)		T _A = 25°C			-40 to 85°C		-55 to 125°C		
				Min.	Typ.	Max.	Min.	Max.	Min.		Max.
V _{IH}	High Level Input Voltage	3.0 to 3.6		2.0			2.0		2.0		V
V _{IL}	Low Level Input Voltage					0.8		0.8		0.8	V
V _{OH}	High Level Output Voltage	3.0	I _O =-50 μA	2.9	2.99		2.9		2.9		V
			I _O =-12 mA	2.58			2.48		2.48		
			I _O =-24 mA				2.2		2.2		
V _{OL}	Low Level Output Voltage	3.0	I _O =50 μA		0.002	0.1		0.1		0.1	V
			I _O =12 mA		0	0.36		0.44		0.44	
			I _O =24 mA					0.55		0.55	
I _I	Input Leakage Current	3.6	V _I = V _{CC} or GND			± 0.1		± 1		± 1	μA
I _{OZ}	High Impedance Output Leakage Current	3.6	V _I = V _{IH} or V _{IL} V _O = V _{CC} or GND			±0.25		± 2.5		± 5.0	μA
I _{CC}	Quiescent Supply Current	3.6	V _I = V _{CC} or GND			4		40		40	μA
I _{OLD}	Dynamic Output Current (note 1, 2)	3.6	V _{OLD} = 0.8 V max				36		25		mA
I _{OHD}			V _{OHD} = 2 V min				-25		-25		mA

1) Maximum test duration 2ms, one output loaded at time

2) Incident wave switching is guaranteed on transmission lines with impedances as low as 75Ω

DYNAMIC SWITCHING CHARACTERISTICS

Symbol	Parameter	Test Condition		Value						Unit	
		V _{CC} (V)		T _A = 25°C			-40 to 85°C		-55 to 125°C		
				Min.	Typ.	Max.	Min.	Max.	Min.		Max.
V _{OLP}	Dynamic Low Voltage Quiet Output (note 1, 2)	3.3	C _L = 50 pF		0.5	0.8					V
V _{OLV}				-0.8	-0.6						
V _{IHD}	Dynamic High Voltage Input (note 1, 3)	3.3		2							V
V _{ILD}	Dynamic Low Voltage Input (note 1, 3)	3.3				0.8					V

1) Worst case package.

2) Max number of outputs defined as (n). Data inputs are driven 0V to 3.3V, (n-1) outputs switching and one output at GND.

3) Max number of data inputs (n) switching. (n-1) switching 0V to 3.3V. Inputs under test switching: 3.3V to threshold (V_{ILD}), 0V to threshold (V_{IHD}), f=1MHz.

AC ELECTRICAL CHARACTERISTICS ($C_L = 50 \text{ pF}$, $R_L = 500 \Omega$, Input $t_r = t_f = 3\text{ns}$)

Symbol	Parameter	Test Condition		Value						Unit	
		V_{CC} (V)		$T_A = 25^\circ\text{C}$			$-40 \text{ to } 85^\circ\text{C}$		$-55 \text{ to } 125^\circ\text{C}$		
				Min.	Typ.	Max.	Min.	Max.	Min.		Max.
t_{PLH} t_{PHL}	Propagation Delay Time	2.7			6.6	11		12.5		14	ns
		3.3(*)			5.8	9		10.5		12	
t_{PZL} t_{PZH}	Output Enable Time	2.7			9.2	13.5		15		18	ns
		3.3(*)			7.6	10		11.5		13	
t_{PLZ} t_{PHZ}	Output Disable Time	2.7			9.0	12		13.5		15	ns
		3.3(*)			7.3	9.0		10.5		12	
t_{OSLH} t_{OSHL}	Output To Output Skew Time (note1, 2)	2.7			0.5	1.0		1.0		1.0	ns
		3.3(*)			0.5	1.0		1.0		1.0	

1) Skew is defined as the absolute value of the difference between the actual propagation delay for any two outputs of the same device switching in the same direction, either HIGH or LOW ($t_{OSLH} = |t_{PLHm} - t_{PLHn}|$, $t_{OSHL} = |t_{PHLm} - t_{PHLn}|$)

2) Parameter guaranteed by design

(*) Voltage range is $3.3\text{V} \pm 0.3\text{V}$

CAPACITIVE CHARACTERISTICS

Symbol	Parameter	Test Condition		Value						Unit	
		V_{CC} (V)		$T_A = 25^\circ\text{C}$			$-40 \text{ to } 85^\circ\text{C}$		$-55 \text{ to } 125^\circ\text{C}$		
				Min.	Typ.	Max.	Min.	Max.	Min.		Max.
C_{IN}	Input Capacitance	3.3			4						pF
C_{OUT}	Output Capacitance	3.3			8						pF
C_{PD}	Power Dissipation Capacitance (note 1)	3.3	$f_{IN} = 10\text{MHz}$		10						pF

1) C_{PD} is defined as the value of the IC's internal equivalent capacitance which is calculated from the operating current consumption without load. (Refer to Test Circuit). Average operating current can be obtained by the following equation. $I_{CC(opr)} = C_{PD} \times V_{CC} \times f_{IN} + I_{CC}/8$ (per Gate)

TEST CIRCUIT

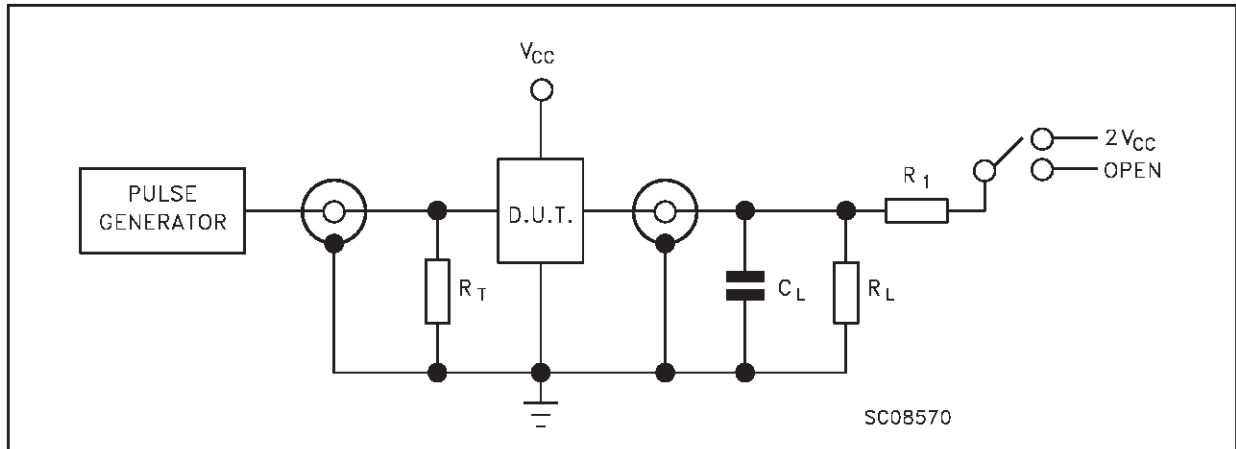

TEST	SWITCH
t_{PLH} , t_{PHL}	Open
t_{PZL} , t_{PLZ}	$2V_{CC}$
t_{PZH} , t_{PHZ}	Open

$C_L = 50\text{pF}$ or equivalent (includes jig and probe capacitance)
 $R_L = R_1 = 500\Omega$ or equivalent
 $R_T = Z_{OUT}$ of pulse generator (typically 50Ω)

WAVEFORM 1 : PROPAGATION DELAYS (f=1MHz; 50% duty cycle)

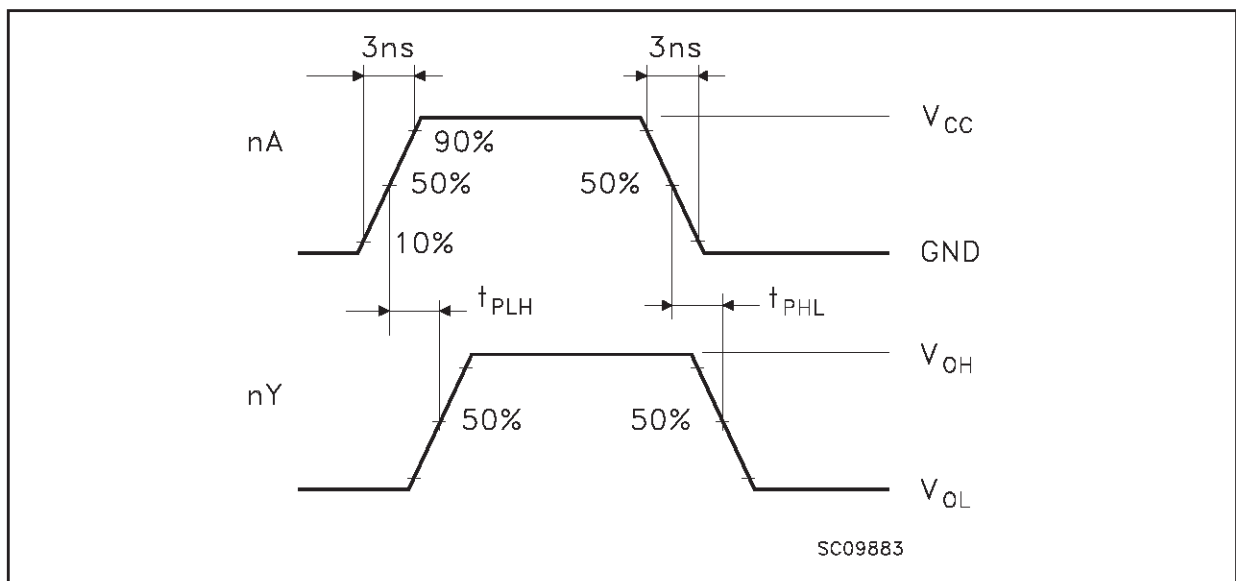

WAVEFORM 2 : OUTPUT ENABLE AND DISABLE TIMES (f=1MHz; 50% duty cycle)

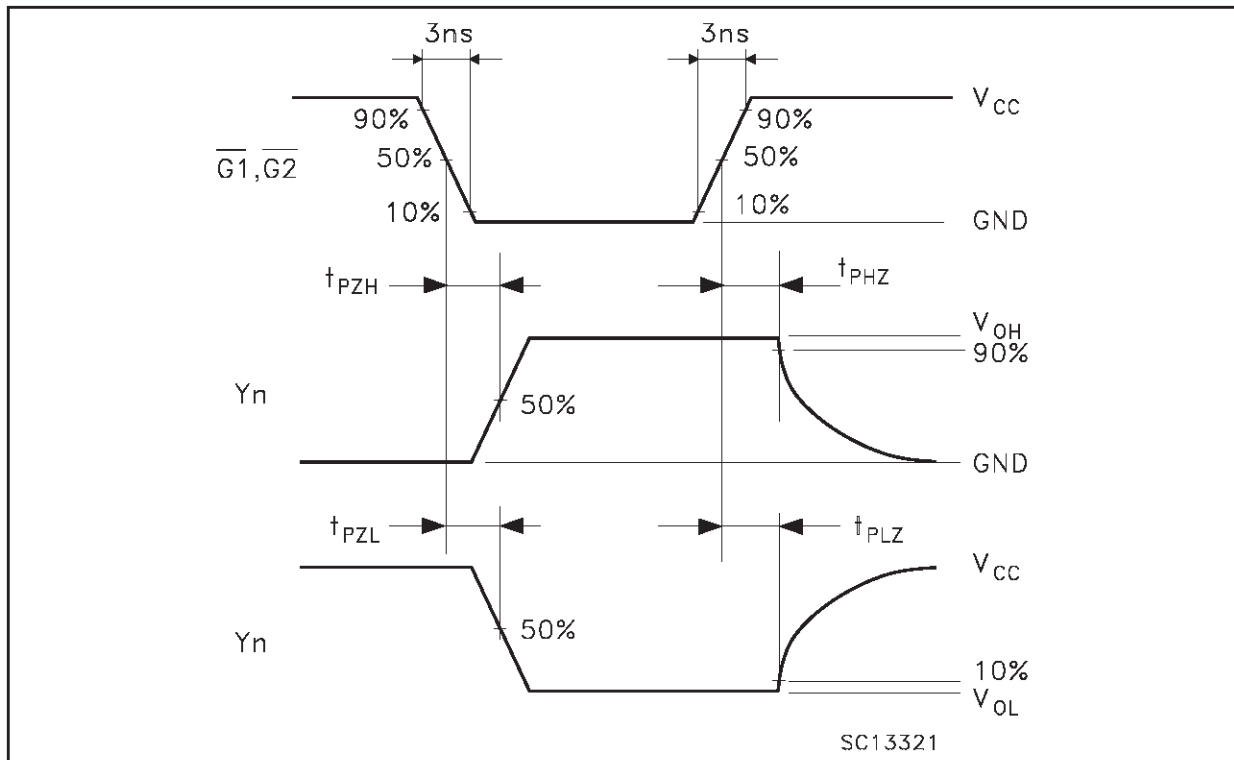

SO-20 MECHANICAL DATA

DIM.	mm.			inch		
	MIN.	TYP.	MAX.	MIN.	TYP.	MAX.
A			2.65			0.104
a1	0.1		0.2	0.004		0.008
a2			2.45			0.096
b	0.35		0.49	0.014		0.019
b1	0.23		0.32	0.009		0.012
C		0.5			0.020	
c1	45° (typ.)					
D	12.60		13.00	0.496		0.512
E	10.00		10.65	0.393		0.419
e		1.27			0.050	
e3		11.43			0.450	
F	7.40		7.60	0.291		0.300
L	0.50		1.27	0.020		0.050
M			0.75			0.029
S	8° (max.)					

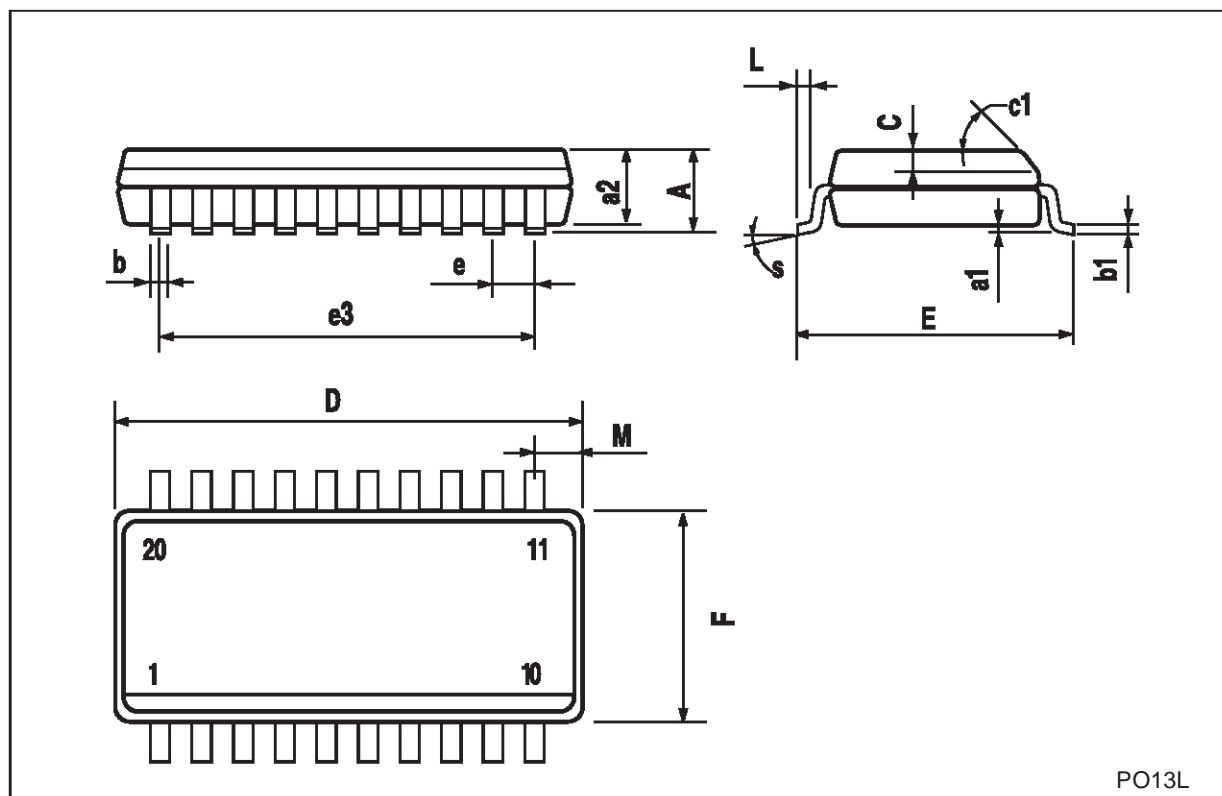

PO13L

TSSOP20 MECHANICAL DATA

DIM.	mm.			inch		
	MIN.	TYP	MAX.	MIN.	TYP.	MAX.
A			1.2			0.047
A1	0.05		0.15	0.002	0.004	0.006
A2	0.8	1	1.05	0.031	0.039	0.041
b	0.19		0.30	0.007		0.012
c	0.09		0.20	0.004		0.0089
D	6.4	6.5	6.6	0.252	0.256	0.260
E	6.2	6.4	6.6	0.244	0.252	0.260
E1	4.3	4.4	4.48	0.169	0.173	0.176
e		0.65 BSC			0.0256 BSC	
K	0°		8°	0°		8°
L	0.45	0.60	0.75	0.018	0.024	0.030

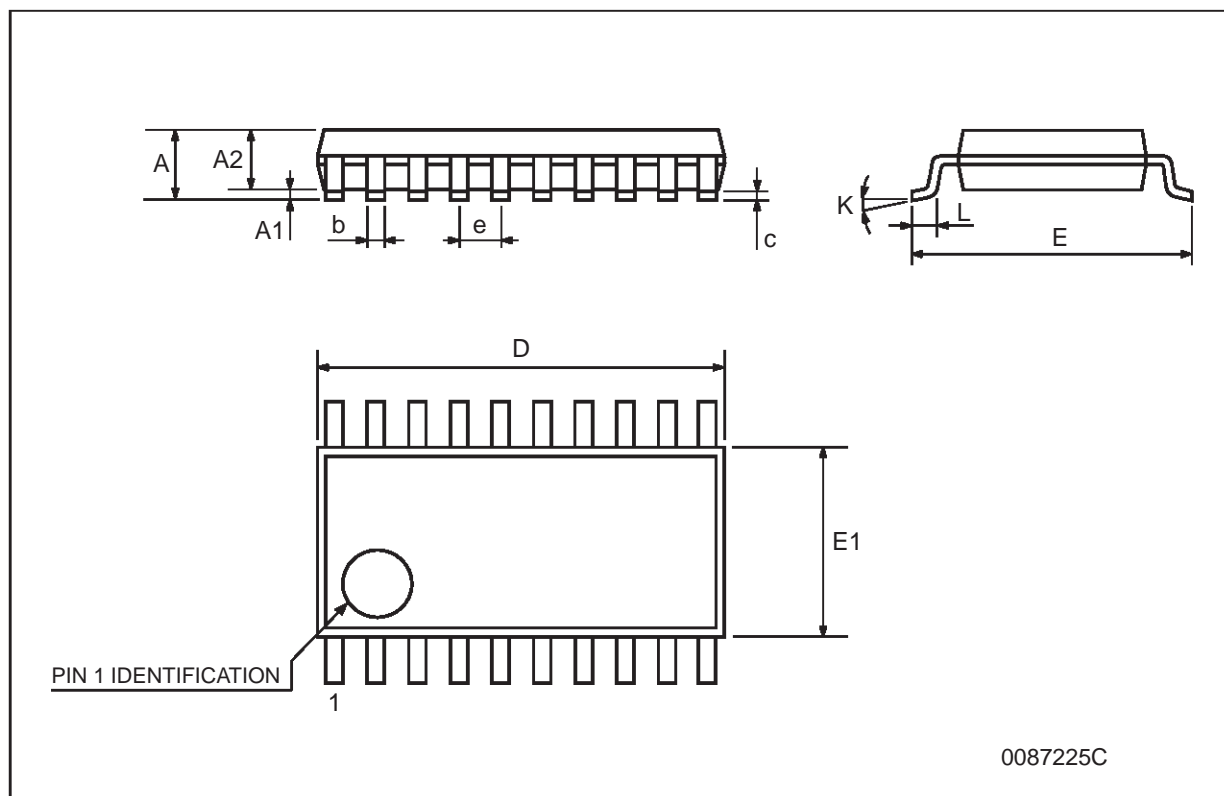

Information furnished is believed to be accurate and reliable. However, STMicroelectronics assumes no responsibility for the consequences of use of such information nor for any infringement of patents or other rights of third parties which may result from its use. No license is granted by implication or otherwise under any patent or patent rights of STMicroelectronics. Specifications mentioned in this publication are subject to change without notice. This publication supersedes and replaces all information previously supplied. STMicroelectronics products are not authorized for use as critical components in life support devices or systems without express written approval of STMicroelectronics.

© The ST logo is a registered trademark of STMicroelectronics

© 2001 STMicroelectronics - Printed in Italy - All Rights Reserved
STMicroelectronics GROUP OF COMPANIES

Australia - Brazil - China - Finland - France - Germany - Hong Kong - India - Italy - Japan - Malaysia - Malta - Morocco
Singapore - Spain - Sweden - Switzerland - United Kingdom

© <http://www.st.com>

