

**DATA SHEET**

# CX65001: 160 – 700 MHz Linear Power Amplifier Driver

## Applications

- TETRA transceivers
- GSM400
- Wireless Local Loop (WLL) and Industrial, Scientific, Medical (ISM) bands
- Repeaters
- Paging
- Mobile radios
- VHF/UHF TV broadcast

## Features

- 5 V single supply operation
- Linear P<sub>OUT</sub> of 24 dBm
- OIP3 of 45 dBm
- Internal bias circuits
- 8-pin SOIC 5.994 x 4.928 mm package with downset paddle

## Description

Skyworks CX65001 power amplifier driver offers a desirable combination of features that provide superb performance and ease of use in a low-cost Surface-Mounted Technology (SMT) package. The Gallium Arsenide (GaAs) Heterojunction Bipolar Transistor (HBT) device was developed and optimized for extreme linear performance in a variety of applications. It is ideal as a driver or output stage for transceivers and repeaters for Trans-European Trunked Radio (TETRA) transceivers, GSM400 and paging base stations, mobile radios, and many other applications.

The 8-pin Small Outline Integrated Circuit (SOIC) device package and pinout are shown in Figure 1. Figure 2 shows a functional block diagram for the CX65001. Signal pin assignments and functional pin descriptions are provided in Table 1.

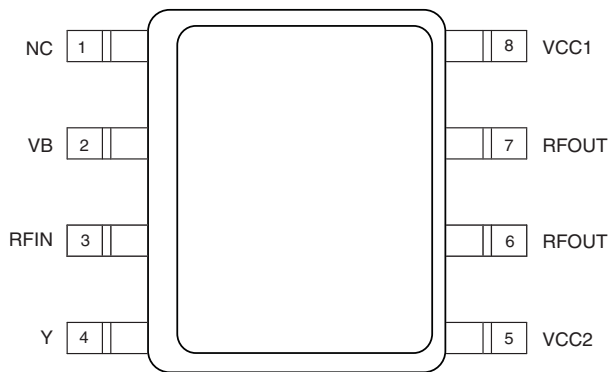

C1215

**Figure 1. CX65001 Pinout – 8-Pin SOIC Package Top View**

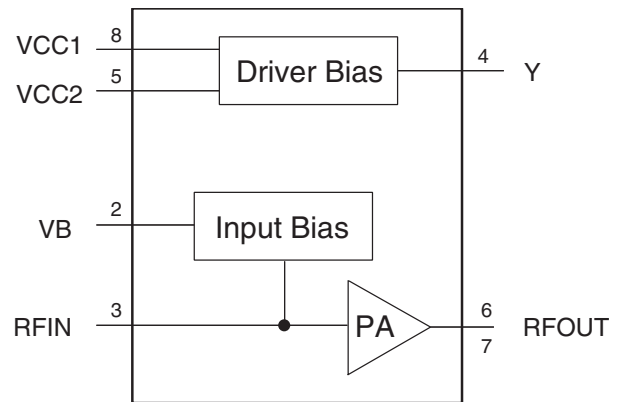

C1216

**Figure 2. CX65001 Functional Block Diagram**

**Table 1. CX65001 Signal Descriptions**

Pin #	Name	Description	Pin #	Name	Description
1	NC	No connection	5	VCC2	Supply voltage
2	VB	Input bias for amplifier driver	6	RFOUT	RF output
3	RFIN	RF input	7	RFOUT	RF output
4	Y	Output of internal bias circuit	8	VCC1	Supply voltage

**Table 2. CX65001 Absolute Maximum Ratings**

Parameter	Symbol	Min	Typical	Max	Units
RF input power	$P_{IN}$			6	dBm
Supply voltage (VCC1 and VCC2 pins)	VCC			6	V
Supply current ( $I_b + I_{BIAS}$ )	$I_{CC}$			240	mA
Power dissipation				1.3	W
Case operating temperature	$T_c$	-40		+85	°C
Storage temperature	$T_{ST}$	-55		+125	°C
Junction temperature	$T_J$			+150	°C

**Note:** Exposure to maximum rating conditions for extended periods may reduce device reliability. There is no damage to device with only one parameter set at the limit and all other parameters set at or below their nominal value.

### Technical Description

The CX65001 is a single stage linear amplifier. The device can be externally matched for optimum gain and linearity using two to three passive components. These external components allow the amplifier to be set to a desired operating frequency.

The CX65001 contains a bias circuit for optimum temperature tracking performance. An external resistor is used to set the bias current level. The value of this resistor can be selected to set the amplifier operational mode to Class A, B, or AB.

### Package and Handling Information

Since the device package is sensitive to moisture absorption, it is baked and vacuum packed before shipping. Instructions on the shipping container label regarding exposure to moisture after the container seal is broken must be followed. Otherwise, problems related to moisture absorption may occur when the part is subjected to high temperature during solder assembly.

If the part is attached in a reflow oven, the temperature ramp rate should not exceed 5 °C per second. Maximum temperature should not exceed 225 °C and the time spent at a temperature that exceeds 210 °C should be limited to less than 10 seconds. If the part is manually attached, precaution should be taken to

ensure that the part is not subjected to a temperature that exceeds 300 °C for more than 10 seconds.

Care must be taken when attaching this product, whether it is done manually or in a production solder reflow environment. Production quantities of this product are shipped in a standard tape and reel format. For packaging details, refer to the Skyworks Application Note, *Tape and Reel*, document number 101568.

### Electrical and Mechanical Specifications

The absolute maximum ratings of the CX65001 are provided in Table 2. The recommended operating conditions are specified in Table 3 and electrical specifications are provided in Table 4.

Typical performance characteristics of the CX65001 are shown in Figures 3 through 11. Figure 12 shows the package dimensions for the 8-pin CX65001 SOIC and Figure 13 provides the tape and reel dimensions.

### Electrostatic Discharge (ESD) Sensitivity

The CX65001 is a static-sensitive electronic device. Do not operate or store near strong electrostatic fields. Take proper ESD precautions.

**Table 3. CX65001 Recommended Operating Conditions**

Parameter	Symbol	Min	Typical	Max	Units
Supply voltage (VCC1 and VCC2 pins)	VCC		5		V
Operating frequency	F <sub>0</sub>	160		700	MHz
Junction temperature	T <sub>J</sub>			140	°C
Maximum bias condition		$(VCC \times I_b) < (T_{J\_RECOMMENDED} - T_c)/R_{TH,J-C}$			

**Table 4. CX65001 Electrical Characteristics**  
(VCC = 5.0 V, Frequency = 450 MHz, Tc = 25 °C, unless otherwise noted)

Parameter	Symbol	Test Conditions	Min	Typical	Max	Units
<b>Analog Inputs</b>						
Quiescent current	I <sub>0</sub>			120	130	mA
Small signal gain	G	P <sub>IN</sub> = -15 dBm	21	22		dB
Output power	P <sub>OUT</sub>	P <sub>IN</sub> = 3 dBm	23	24		dBm
Efficiency	PAE	P <sub>IN</sub> = 3 dBm	35	42		%
Noise Figure (NF)	NF			5	6	dB
Output IP3	OIP3	Two tones with 1 MHz spacing, P <sub>IN</sub> = -16 dBm per tone	40	45		dBm
Thermal resistance (junction – case)	R <sub>TH,J-C</sub>			65		°C/W

**Note:** The above specifications apply only to the 450 MHz operating frequency.

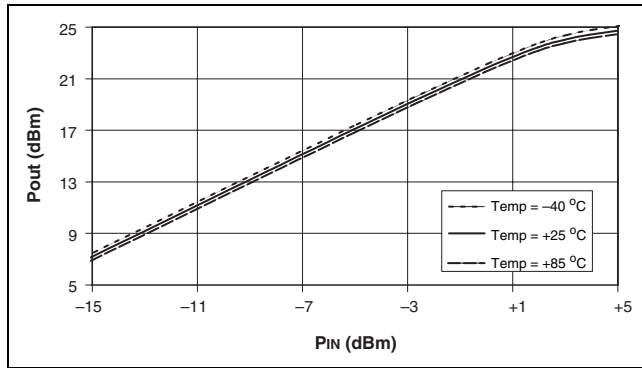

**Figure 3. Typical P<sub>OUT</sub> vs P<sub>IN</sub> @ 450 MHz Over Temperature**  
(Circuit Match for Optimum OIP3)

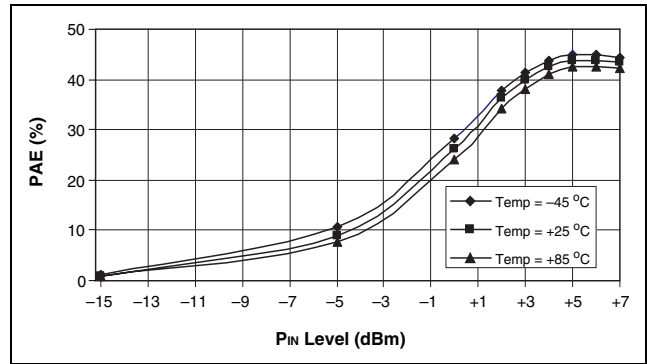

**Figure 4. Typical PAE vs P<sub>IN</sub> @ 450 MHz Over Temperature**  
(Circuit Match for Optimum OIP3)

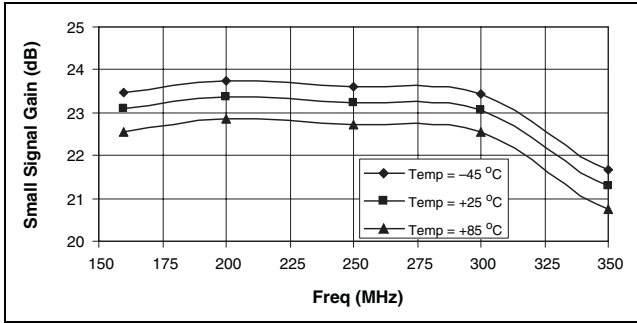

Figure 5. Typical Small Signal Gain From 160 to 300 MHz Over Temperature (Circuit Match for Optimum Gain)

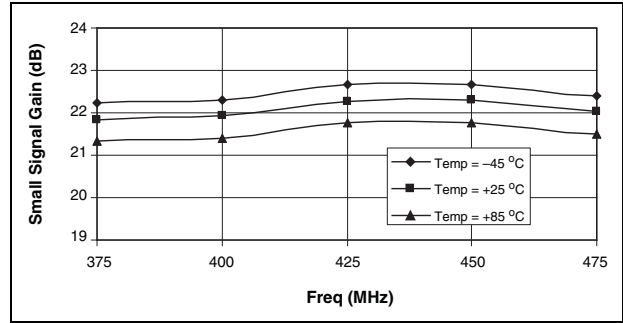

Figure 6. Typical Small Signal Gain From 375 to 475 MHz Over Temperature (Circuit Match for Optimum OIP3)

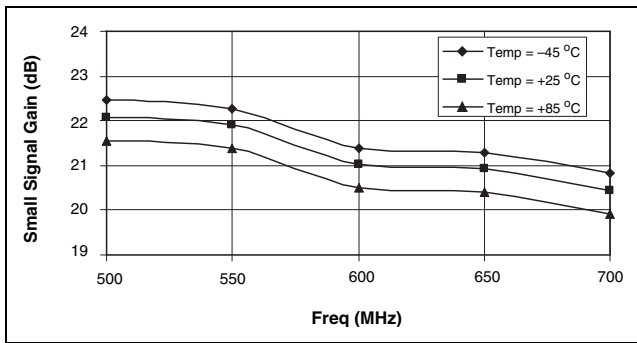

Figure 7. Typical Small Signal Gain From 500 to 700 MHz Over Temperature (Circuit Match for Optimum Gain)

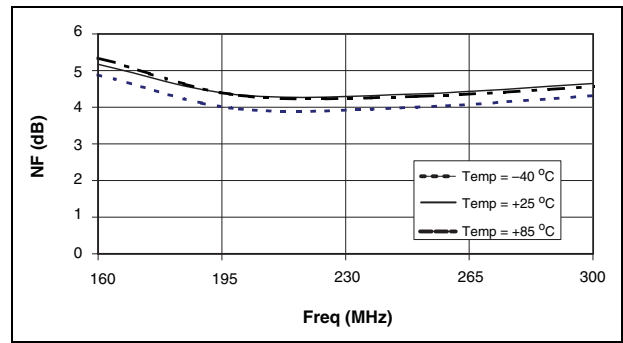

Figure 8. Typical Noise Figure From 160 to 300 MHz Over Temperature (Circuit Match for Optimum Gain)

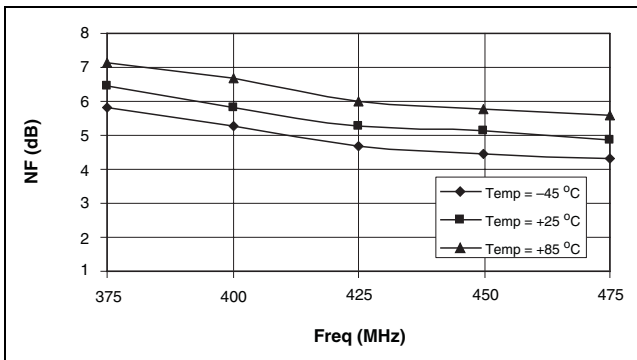

Figure 9. Typical Noise Figure From 375 to 475 MHz Over Temperature (Circuit Match for Optimum OIP3)

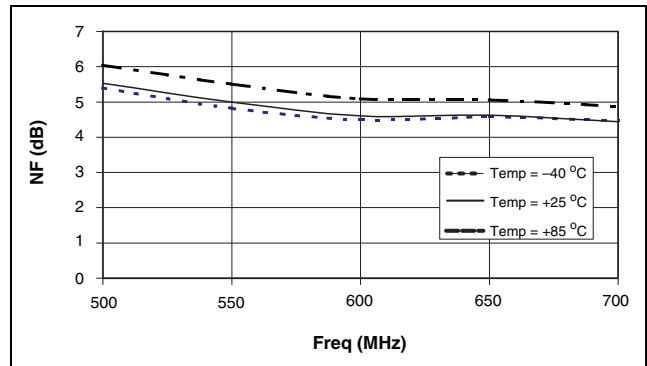
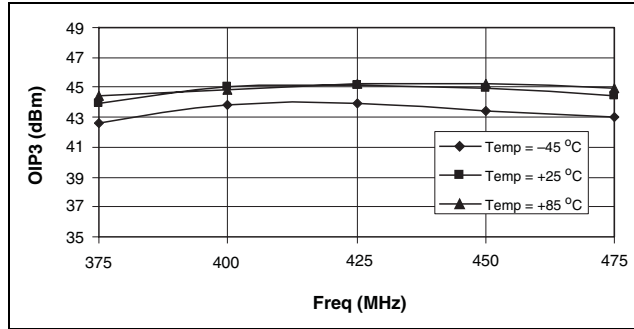
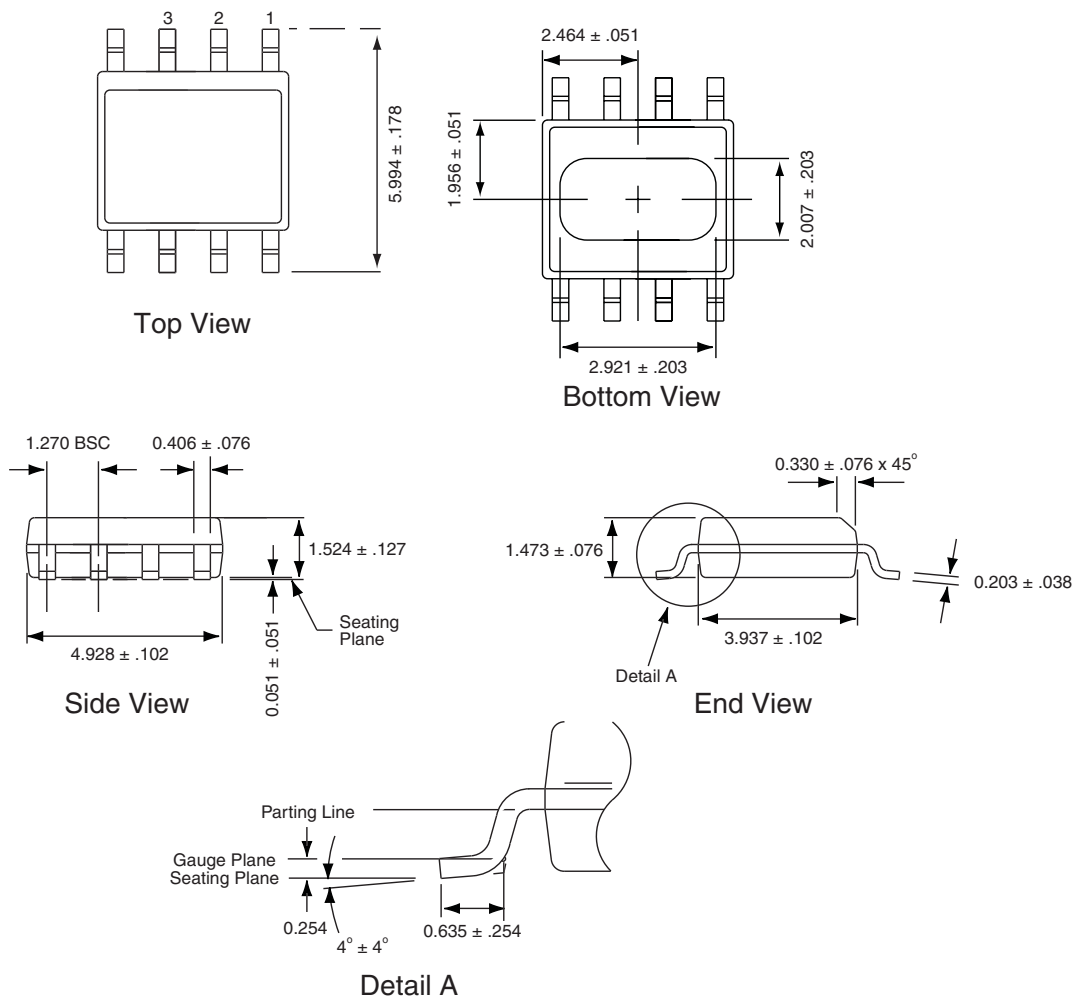

Figure 10. Typical Noise Figure From 500 to 700 MHz Over Temperature (Circuit Match for Optimum Gain)



**Figure 11. Typical OIP3 From 375 to 475 MHz Over Temperature (Circuit Match for Optimum OIP3)**



All measurements are in millimeters

C1444

**Figure 12. CX65001 8-Pin SOIC Package Dimensions**

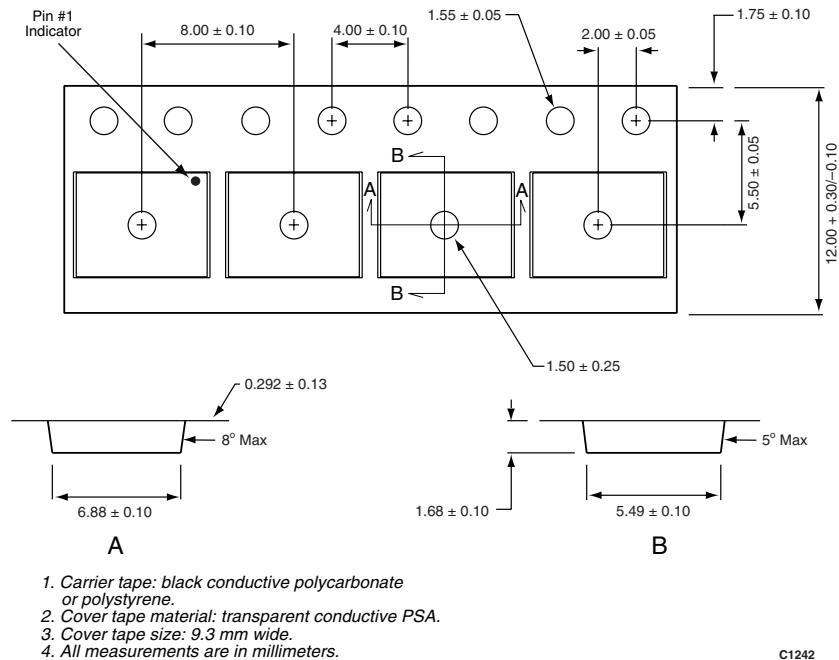

**Figure 13. CX65001 8-Pin SOIC Tape and Reel Dimensions**

### Evaluation Board Description

Skyworks CX65001 Evaluation Board is used to test the performance of the CX65001 power amplifier driver. The Evaluation Board schematic diagram is shown in Figure 14. The schematic shows the basic design of the board for the 375 to 475 MHz range. Figure 15 provides the Evaluation Board assembly diagram. Figure 16 provides the Evaluation Board layer detail. The mounting footprint for the CX65001 is shown in Figure 17.

### Circuit Design Considerations

The following design considerations are general in nature and must be followed regardless of final use or configuration

1. Paths to ground should be made as short as possible.
2. The ground pad of the CX65001 power amplifier has special electrical and thermal grounding requirements. This pad is the main thermal conduit for heat dissipation. Since the circuit board acts as the heat sink, it must shunt as much heat as possible from the amplifier. As such, design the connection to the ground pad to dissipate the maximum wattage produced to the circuit board. Multiple vias to the grounding layer are required.

**NOTE:** Junction temperature ( $T_j$ ) of the device increases with a poor connection to the slug and ground. This reduces the lifetime of the device.

3. External bypass capacitors are required on the VCC line and on pins 4, 5, and 8.
4. Bias resistor R1 is used to control the reference voltage of the bias circuit (VCC1) at pin 8.
5. Inductor L2 is placed between the bias circuit output (pin 4) and the base of the RF transistor (pin 2) for bias circuit and RF transistor connection.

A suggested matching circuit is shown in Figure 14.

### Testing Procedure

Use the following procedure to set up the CX65001 Evaluation Board for testing. Refer to Figure 18 for guidance:

1. Connect a +5.0 V supply voltage to VCC. If available, enable the current limiting function of the power supply to 240 mA.
2. Connect a signal generator to the RF signal input port. Set it to the desired RF frequency at a power level of -15 dBm or less to the Evaluation Board but do NOT enable the RF signal.
3. Connect a spectrum analyzer to the RF signal output port.
4. Enable the power supply.
5. Enable the RF signal.
6. Take measurements.

**CAUTION:** If the input signal exceeds the rated power, the CX65001 Evaluation Board can be permanently damaged.

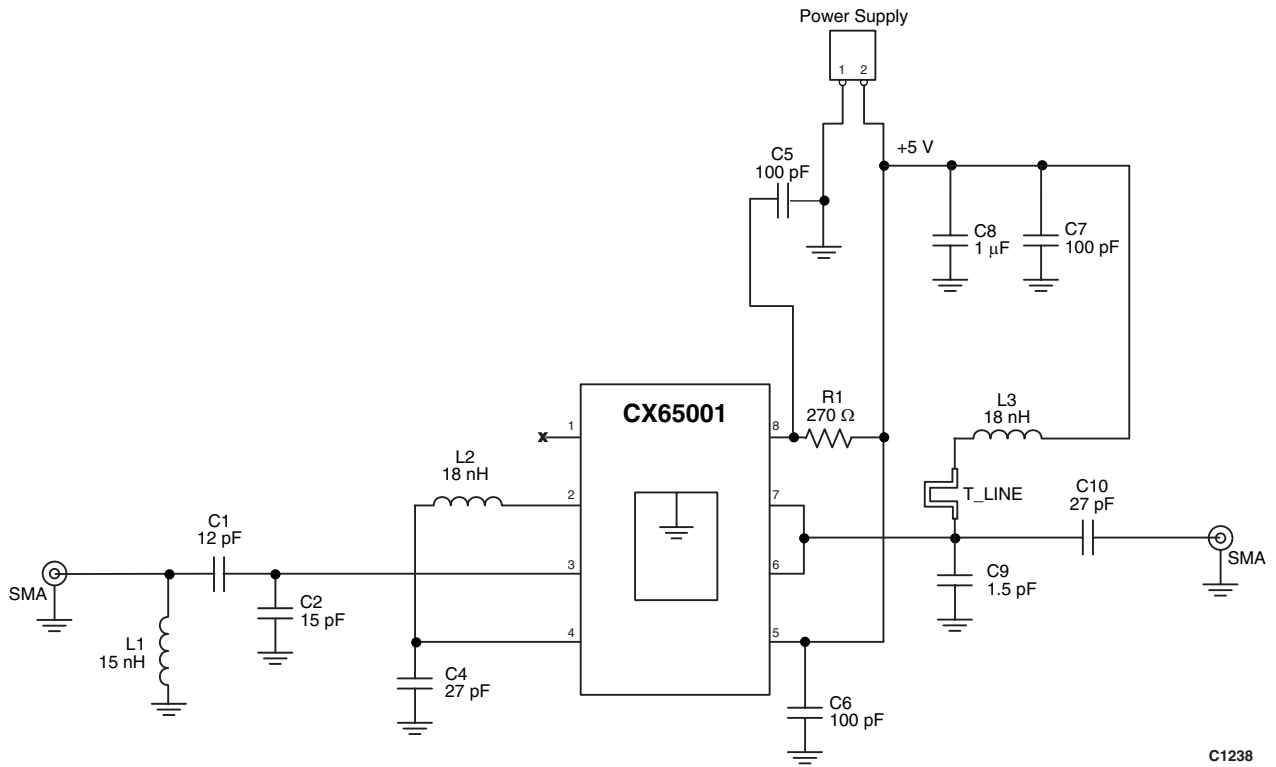

C1238

Figure 14. Application Schematic Optimized for OIP3 @ 450 MHz

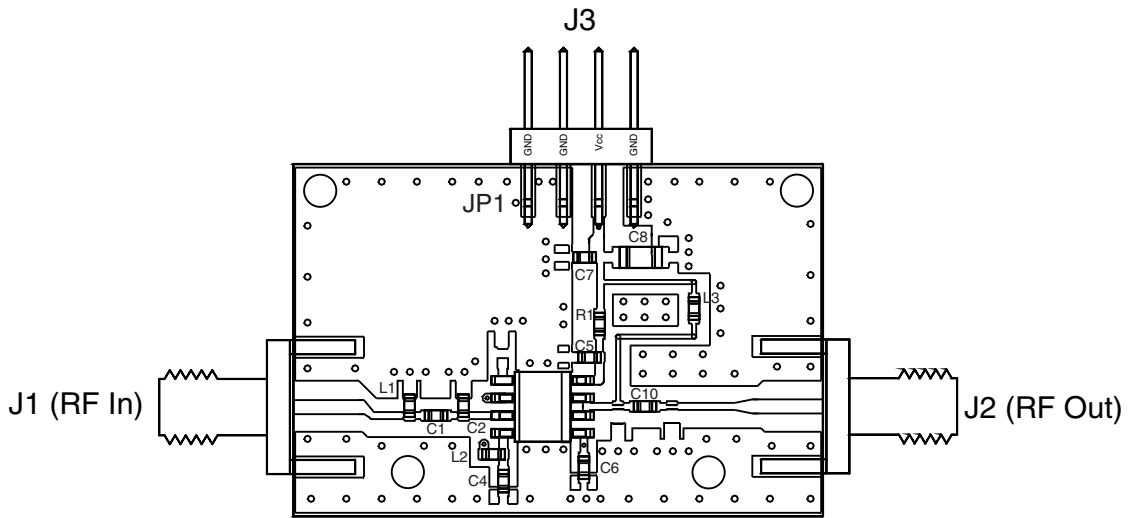

C1437

Figure 15. Evaluation Board Assembly Diagram

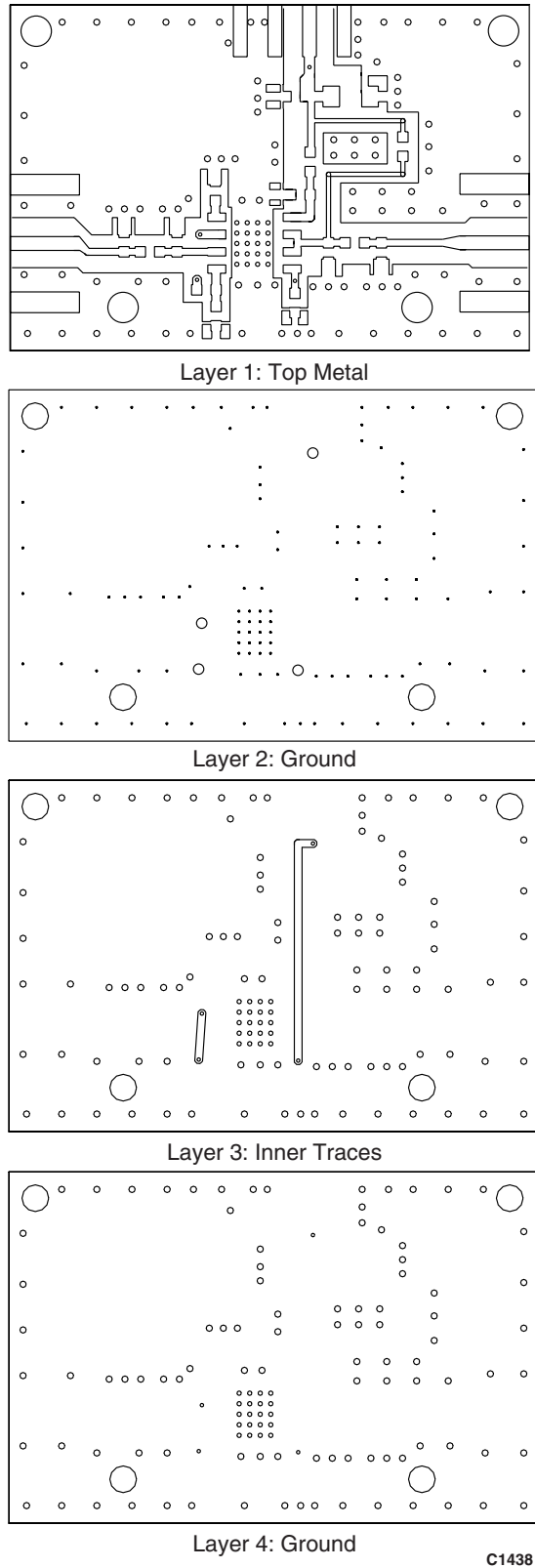

C1438

Figure 16. Evaluation Board Layer Detail



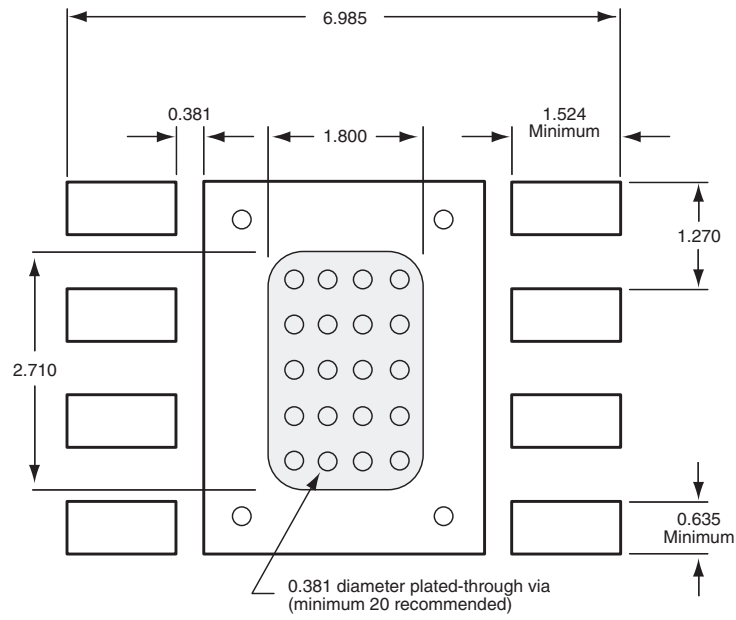

Dimensions are in millimeters

C1218

**Figure 17. PCB Mounting Footprint**

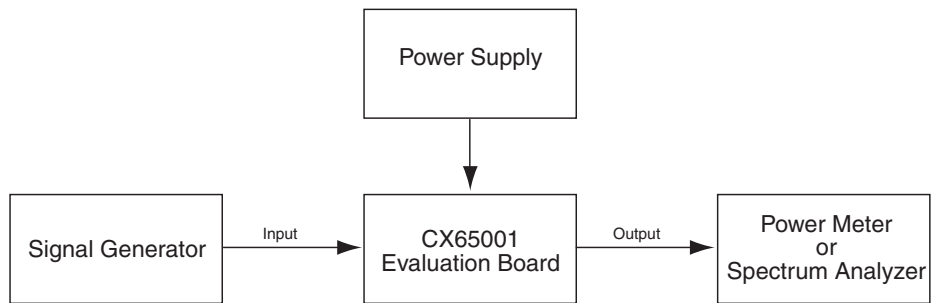

C1240e

**Figure 18. CX65001 Evaluation Board Testing Configuration**

## Ordering Information

Model Name	Manufacturing Part Number	Evaluation Kit Part Number
CX65001 160-700 MHz Linear Power Amplifier Driver	CX65001-12	TW10-D282 (tuned for optimum OIP3 @ 450 MHz )

Copyright © 2002, 2004, Skyworks Solutions, Inc. All Rights Reserved.

Information in this document is provided in connection with Skyworks Solutions, Inc. ("Skyworks") products. These materials are provided by Skyworks as a service to its customers and may be used for informational purposes only by the customer. Skyworks assumes no responsibility for errors or omissions in these materials. Skyworks may make changes to its documentation, products, specifications and product descriptions at any time, without notice. Skyworks makes no commitment to update the information and shall have no responsibility whatsoever for conflicts, incompatibilities, or other difficulties arising from future changes to its documentation, products, specifications and product descriptions.

No license, express or implied, by estoppel or otherwise, to any intellectual property rights is granted by or under this document. Except as may be provided in Skyworks Terms and Conditions of Sale for such products, Skyworks assumes no liability whatsoever in association with its documentation, products, specifications and product descriptions.

THESE MATERIALS ARE PROVIDED "AS IS" WITHOUT WARRANTY OF ANY KIND, EITHER EXPRESS OR IMPLIED OR OTHERWISE, RELATING TO SALE AND/OR USE OF SKYWORKS PRODUCTS INCLUDING WARRANTIES RELATING TO FITNESS FOR A PARTICULAR PURPOSE, MERCHANTABILITY, PERFORMANCE, QUALITY OR NON-INFRINGEMENT OF ANY PATENT, COPYRIGHT OR OTHER INTELLECTUAL PROPERTY RIGHT. SKYWORKS FURTHER DOES NOT WARRANT THE ACCURACY OR COMPLETENESS OF THE INFORMATION, TEXT, GRAPHICS OR OTHER ITEMS CONTAINED WITHIN THESE MATERIALS. SKYWORKS SHALL NOT BE LIABLE FOR ANY DAMAGES, INCLUDING SPECIAL, INDIRECT, INCIDENTAL, OR CONSEQUENTIAL DAMAGES, INCLUDING WITHOUT LIMITATION, LOST REVENUES OR LOST PROFITS THAT MAY RESULT FROM THE USE OF THESE MATERIALS WHETHER OR NOT THE RECIPIENT OF MATERIALS HAS BEEN ADVISED OF THE POSSIBILITY OF SUCH DAMAGE.

Skyworks products are not intended for use in medical, lifesaving or life-sustaining applications. Skyworks customers using or selling Skyworks products for use in such applications do so at their own risk and agree to fully indemnify Skyworks for any damages resulting from such improper use or sale.

The following are trademarks of Skyworks Solutions, Inc.: Skyworks™, the Skyworks logo, and Breakthrough Simplicity™. Product names or services listed in this publication are for identification purposes only, and may be trademarks of Skyworks or other third parties. Third-party brands and names are the property of their respective owners. Additional information, posted at [www.skyworksinc.com](http://www.skyworksinc.com), is incorporated by reference.