



(V) Preliminary Specification

() Final Specification

Module	20.1"W WSXGA+ Color TFT-LCD
Model Name	M201EW02 V8

Customer	Date
_____	_____
Approved by	
_____	_____
<p>Note: This Specification is subject to change without notice.</p>	

Checked & Approved by	Date
<i>CC Chiu</i>	<u>Sep. 29, 2006</u>
Prepared by	
<i>Katy Chang</i>	<u>Sep. 29, 2006</u>
<p>Desktop Display Business Group / AU Optronics corporation</p>	



Contents

1. Handling Precautions	6
2. General Description	8
2.1 Display Characteristics	8
2.2 Optical Characteristics.....	10
3. Functional Block Diagram	18
4. Absolute Maximum Ratings	20
4.1 TFT LCD Module	20
4.2 Backlight Unit	20
4.3 Absolute Ratings of Environment	20
5. Electrical characteristics	22
5.1 TFT LCD Module	22
5.1.1 Power Specification	22
5.1.2 Signal Electrical Characteristics.....	24
5.2 Backlight Unit	26
6. Signal Characteristic	29
6.1 Pixel Format Image	29
6.2 The input data format	29
6.3 Signal Description	30
6.4 Timing Characteristics	33
6.4.1 Timing Characteristics	34
6.4.2Timing diagram	35
6.5 Power ON/OFF Sequence	37
7. Connector & Pin Assignment	39
7.1 TFT LCD Module	39
7.1.1 Connector	39
7.1.2 Pin Assignment.....	39
7.2 Backlight Unit	41
7.2.1 Signal for Lamp connector	41
8. Reliability	42
9 Shipping Label	44
10. Mechanical Characteristics	45

1. Handling Precautions

- 1) Since front polarizer is easily damaged, pay attention not to scratch it.
- 2) Be sure to turn off power supply when inserting or disconnecting from input connector.
- 3) Wipe off water drop immediately. Long contact with water may cause discoloration or spots.
- 4) When the panel surface is soiled, wipe it with absorbent cotton or other soft cloth.
- 5) Since the panel is made of glass, it may break or crack if dropped or bumped on hard surface.
- 6) Since CMOS LSI is used in this module, take care of static electricity and insure human earth when handling.
- 7) Do not open or modify the Module Assembly.
- 8) Do not press the reflector sheet at the back of the module to any directions.
- 9) In case if a Module has to be put back into the packing container slot after once it was taken out from the container, do not press the center of the CCFL reflector edge. Instead, press at the far ends of the CCFL Reflector edge softly. Otherwise the TFT Module may be damaged.
- 10) At the insertion or removal of the Signal Interface Connector, be sure not to rotate nor tilt the Interface Connector of the TFT Module.
- 11) After installation of the TFT Module into an enclosure, do not twist nor bend the TFT Module even momentary. At designing the enclosure, it should be taken into consideration that no bending/twisting forces are applied to the TFT Module from outside. Otherwise the TFT Module may be damaged.
- 12) Cold cathode fluorescent lamp in LCD contains a small amount of mercury. Please follow local ordinances or regulations for disposal.
- 13) Small amount of materials having no flammability grade is used in the LCD module. The LCD module should be supplied by power complied with requirements of Limited Power Source (IEC60950 or UL1950), or be applied exemption.
- 14) The LCD module is designed so that the CCFL in it is supplied by Limited Current Circuit (IEC60950 or UL1950). Do not connect the CCFL in Hazardous Voltage Circuit.



2. General Description

This specification applies to the 20.1 inch-wide Color TFT-LCD Module M201EW02 v.8.

The display supports the WSXGA+ (1680(H) x 1050(V)) screen format and 16.7M colors (RGB 6-bits+Hi-RFC data).

All input signals are 2 Channel LVDS interface compatible.

This module does not contain an inverter card for backlight.

2.1 Display Characteristics

The following items are characteristics summary on the table under 25 °C condition:

ITEMS	Unit	SPECIFICATIONS
Screen Diagonal	[mm]	511.13 (20.1"Wide)
Active Area	[mm]	433.44 (H) x 270.90(V)
Pixels H x V		1680(x3) x 1050
Pixel Pitch	[mm]	0.258 (per one triad) x 0.258
Pixel Arrangement		R.G.B. Vertical Stripe
Display Mode		Normally White
White Luminance (Center)	[cd/m ²]	300cd/m ² @ 7.5mA (Typ)
Contrast Ratio		TBD
Optical Response Time	[msec]	TBD (Typ, on/off)
Nominal Input Voltage VCC	[Volt]	+5.0 V
Power Consumption (VCC line + CCFL line)	[Watt]	TBD
Weight	[Grams]	2500 (Typ)
Physical Size	[mm]	459.4(W) x 296.4(H) x 16.6(D) (Typ)
Electrical Interface		Dual Channel LVDS
Support Color		16.7M colors (RGB 6-bits+Hi-FRC data)
Temperature Range		
Operating	[°C]	0 to +50
Storage (Shipping)	[°C]	-20 to +60
Surface Treatment		Hard-coating (3H), Anti-Glare treatment
RoHS		RoHS compliance

2.2 Optical Characteristics

The optical characteristics are measured under stable conditions at 25°C:

Item	Unit	Conditions	Min.	Typ.	Max.	Note
Viewing Angle	[degree]	Horizontal (Right)	75	80	-	1
	[degree]	CR = 10 (Left)	75	80	-	
	[degree]	Vertical (Up)	75	80	-	
	[degree]	CR = 10 (Down)	75	80	-	
Luminance Uniformity	[%]		75	80	-	2,3
Response Time	[msec]	Rising Time	-	TBD	TBD	4,6
	[msec]	Falling Time	-	TBD	TBD	
	[msec]	Rising + Falling	-	TBD	TBD	
Color / Chromaticity Coordinates (CIE 1931)		Red x	0.610	0.640	0.670	4
		Red y	0.322	0.352	0.382	
		Green x	0.258	0.288	0.318	
		Green y	0.598	0.628	0.658	
		Blue x	0.117	0.147	0.177	
		Blue y	0.040	0.070	0.100	
		White x	0.283	0.313	0.343	
	White y	0.299	0.329	0.359		
White Luminance at CCFL 7.5mA (central point)	[cd/m ²]		240	300	-	4
Contrast ratio		Normal Direction	800	TBD	-	4
Crosstalk (in75Hz)	[%]				1.5	5
Flicker	[dB]				-20	7

Optical Equipment: BM-5A, BM-7, PR880, or equivalent

Note 1: Definition of viewing angle

Viewing angle is the measurement of contrast ratio ≥ 10 , at the screen center, over a 180° horizontal and 180° vertical range (off-normal viewing angles). The 180° viewing angle range is broken down as follows; 90° (θ) horizontal left and right and 90° (Φ) vertical, high (up) and low (down). The measurement direction is typically perpendicular to the display surface with the screen rotated about its center to develop the desired measurement viewing angle.

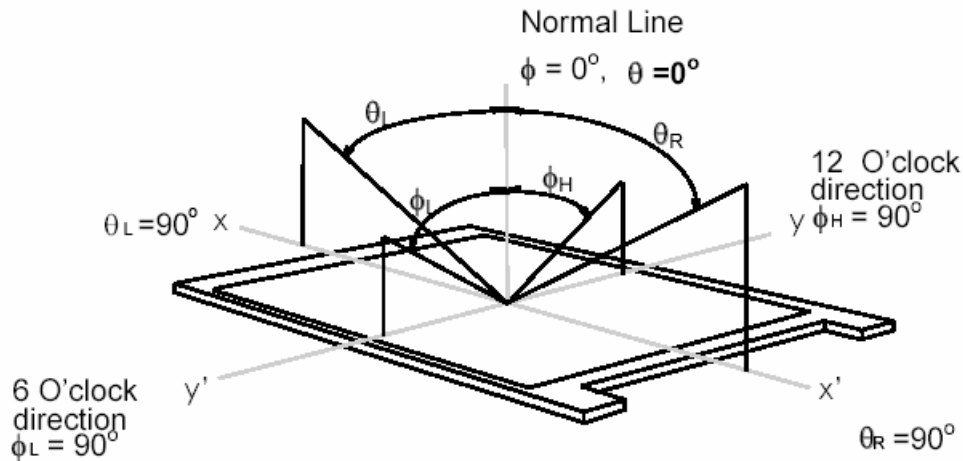

Note 2: 9 points position

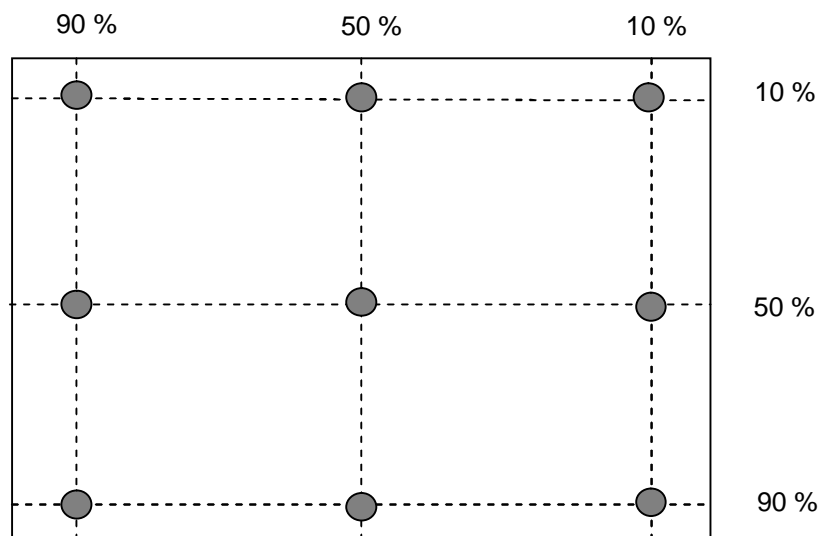

Note 3: The luminance uniformity of 9 points is defined by dividing the maximum luminance values by the minimum test point luminance

$$\delta_{w9} = \frac{\text{Minimum Luminance of 9 points}}{\text{Maximum Luminance of 9 points}}$$

Note 4: Measurement method

The LCD module should be stabilized at given temperature for 30 minutes to avoid abrupt temperature change during measuring. In order to stabilize the luminance, the measurement should be executed after lighting Backlight for 30 minutes in a stable, windless and dark room.

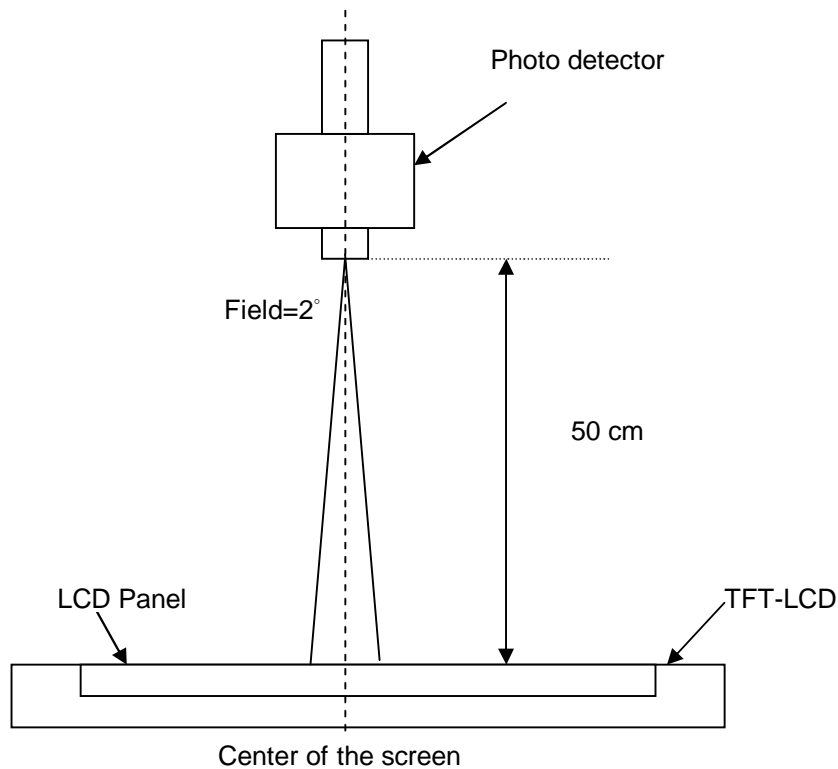

Note 5: Definition of Cross Talk (CT)

$$CT = | YB - YA | / YA \times 100 (\%)$$

Where

YA = Luminance of measured location without gray level 0 pattern (cd/m2)

YB = Luminance of measured location with gray level 0 pattern (cd/m2)

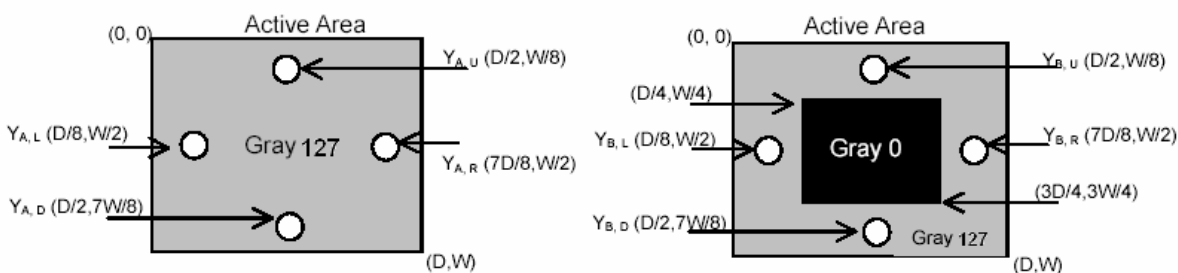

Note 6: Definition of response time:

The output signals of photo detector are measured when the input signals are changed from “Full Black” to “Full White” (rising time), and from “Full White” to “Full Black ”(falling time), respectively. The response time is interval between the 10% and 90% of amplitudes. Please refer to the figure as below.

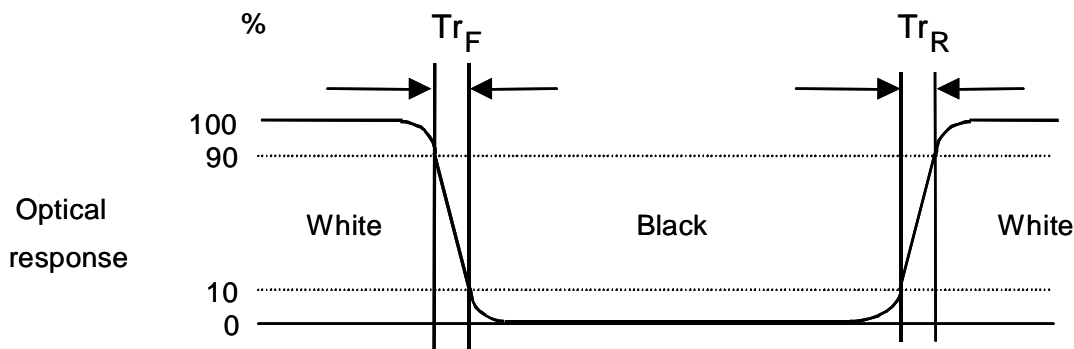

Note 7: Subchecker Pattern

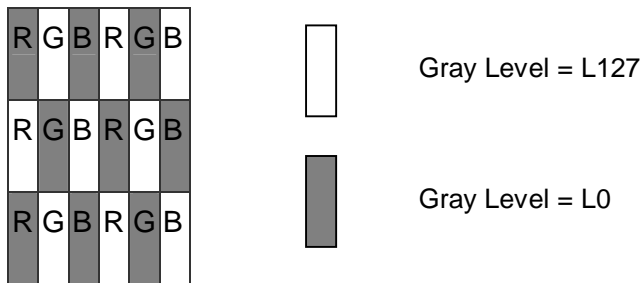

Method: Record dBV & DC value with (WESTAR)TRD-100

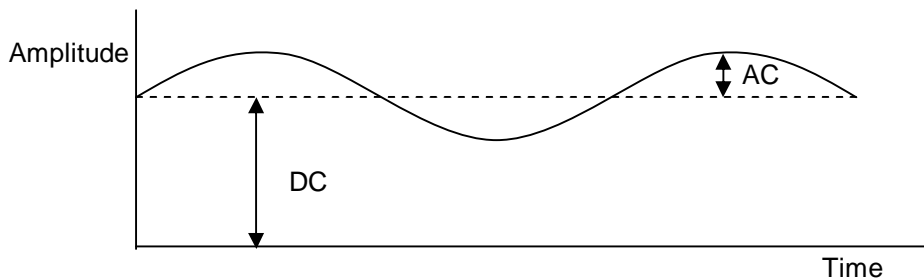

$$\text{Flicker (dB)} = 20 \log \frac{\text{AC Level(at 30 Hz)}}{\text{DC Level}}$$

3. Functional Block Diagram

The following diagram shows the functional block of the 20.1 inches wide Color TFT/LCD Module:

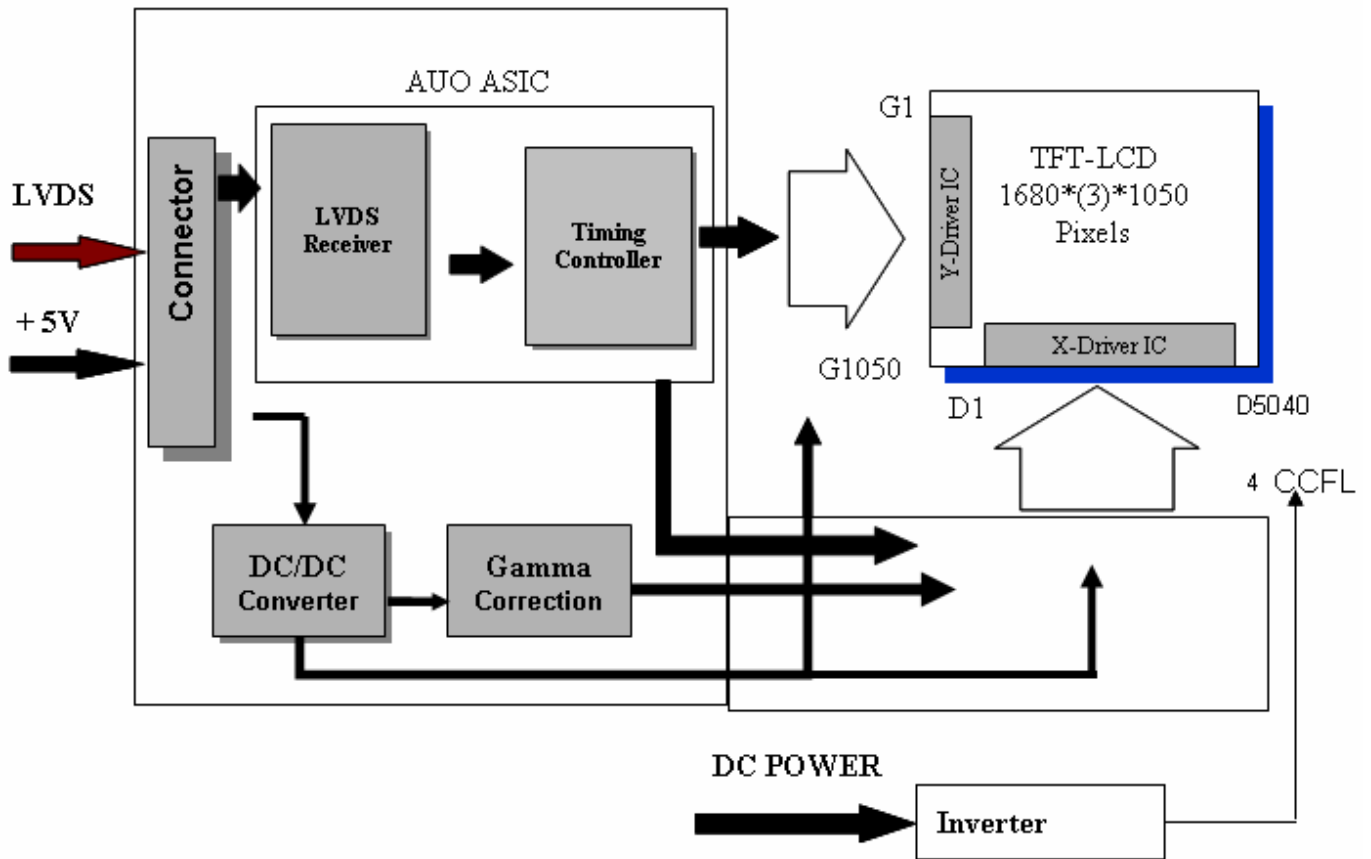

I/F + X-PCB

JAE FI-XB30SSRL-HF16

YEONHO35001HS-02L

4. Absolute Maximum Ratings

Absolute maximum ratings of the module is as following:

4.1 TFT LCD Module

Item	Symbol	Min	Max	Unit	Conditions
Logic/LCD Drive	VIN	-0.3	6	[Volt]	Note 1,2

4.2 Backlight Unit

Item	Symbol	Min	Max	Unit	Conditions
CCFL Current	ICFL	-	8	[mA] rms	Note 1,2

4.3 Absolute Ratings of Environment

Item	Symbol	Min	Max	Unit	Conditions
Operating Humidity	HOP	5	90	[%RH]	Note 3
Storage Temperature	TST	-20	+60	[°C]	
Storage Humidity	HST	5	90	[%RH]	

Note 1: With in Ta (25°C)

Note 2: Permanent damage to the device may occur if exceed maximum values

Note 3: For quality performance, please refer to AUO IIS (Incoming Inspection Standard).

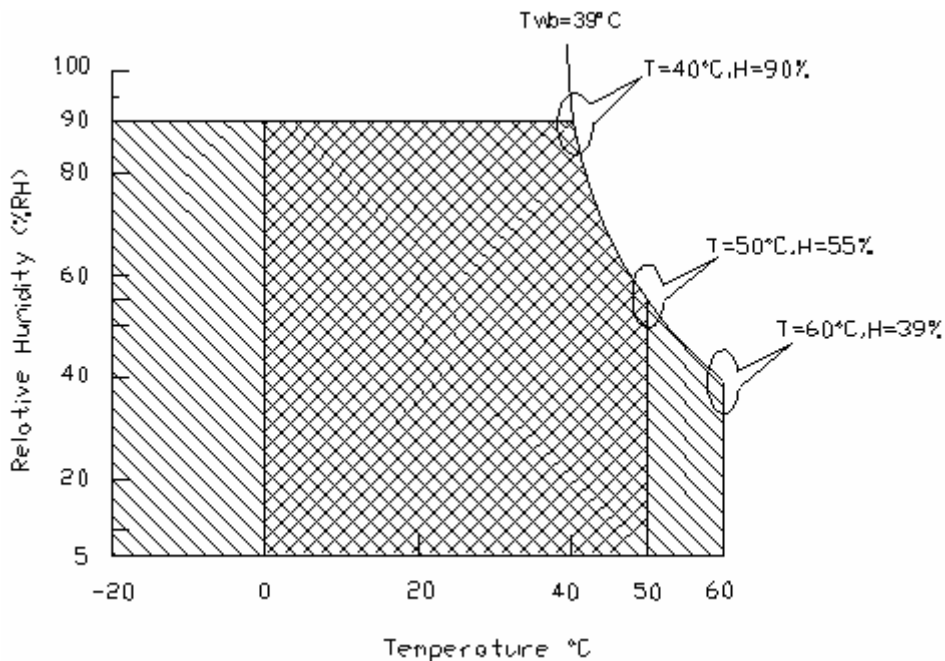

Operating Range



Storage Range



5. Electrical characteristics

5.1 TFT LCD Module

5.1.1 Power Specification

Input power specifications are as follows;

Symbol	Parameter	Min	Typ	Max	Units	Condition
VCC	Logic/LCD Drive Voltage	4.5	5	5.5	[Volt]	± 10%
ICC	VCC current	-	TBD	TBD	[mA]	Vin=5V , All Black Pattern, at 60Hz
Irush	LCD Inrush Current	-	-	TBD	[A]	Note
PCC	VCC Power	-	TBD	TBD	[Watt]	Vin=5V , All Black Pattern, at 60Hz

Note: Measurement conditions:

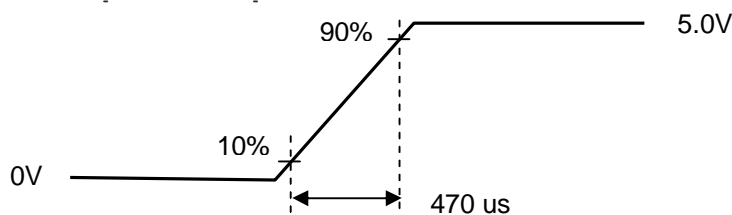
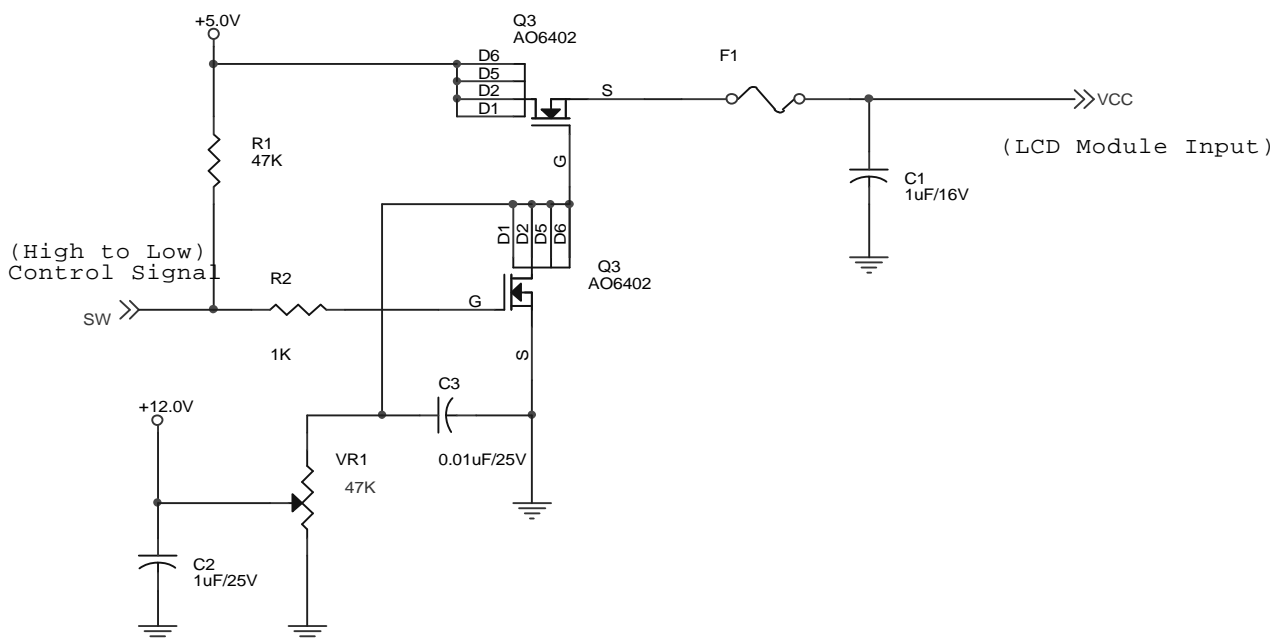

Vin rising time

5.2 Backlight Unit

Parameter guideline for CCFL Inverter

Symbol	Parameter	Min.	Typ.	Max.	Unit	Condition
ISCFL	CCFL standard current	7	7.5	8	[mA] rms	(Ta=25°C) Note 2
IRCFL	CCFL operation range	3	7.5	8	[mA] rms	(Ta=25°C) Note 2
FCFL	CCFL Frequency	40	55	60	[KHz]	(Ta=25°C) Note 3,4
ViCFL (0°C)	CCFL Ignition Voltage (End of the lamp wire connector)	1700	-		[Volt] rms	(Ta=0°C) Note 5
ViCF (25°C)	CCFL Ignition Voltage (End of the lamp wire connector)	1300	-		[Volt] rms	(Ta=25°C) Note 5
VCFL	CCFL Operation Voltage	TBD	750 @7.5mA	TBD	[Volt] rms	(Ta=25°C) Note 6
PCFL	CCFL Power consumption (for reference)	-	TBD	-	[Watt]	(Ta=25°C) Note 6
LTCFL	CCFL life Time	50,000	55,000	-	[Hour]	(Ta=25°C) Note 7

Note 1: Typ. are AUO recommended design points.

- *1 All of characteristics listed are measured under the condition using the AUO test inverter.
- *2 In case of using an inverter other than listed, it is recommended to check the inverter carefully. Sometimes, interfering noise stripes appear on the screen, and substandard luminance or flicker at low power may happen.
- *3 In designing an inverter, it is suggested to check safety circuit very carefully. Impedance of CCFL, for instance, becomes more than 1 [M ohm] when CCFL is damaged.
- *4 Generally, CCFL has some amount of delay time after applying kick-off voltage. It is recommended to keep on applying kick-off voltage for 1 [Sec] until discharge.
- *5 Reducing CCFL current increases CCFL discharge voltage and generally increases CCFL discharge frequency. So all the parameters of an inverter should be carefully designed so as not to produce too much leakage current from high-voltage output of the inverter.

Note 2: It should be employed the inverter which has "Duty Dimming", if IRCFL is less than 4mA.

Note 3: CCFL discharge frequency should be carefully determined to avoid interference between inverter and TFT LCD.

Note 4: The frequency range will not affect to lamp life and reliability characteristics.

Note 5: CCFL inverter should be able to give out a power that has a generating capacity of over 1,500 voltage. Lamp units need 1,500 voltage minimum for ignition.

Note 6: The variance of CCFL power consumption is ±10%. Calculator value for reference (ISCFL × VCFL × 4 = PCFL)

Note 7: Definition of Life time: Brightness becomes 50%. The typical life time CCFL in on the condition at 7.5 m A lamp current.

6. Signal Characteristic

6.1 Pixel Format Image

Following figure shows the relationship of the input signals and LCD pixel format.

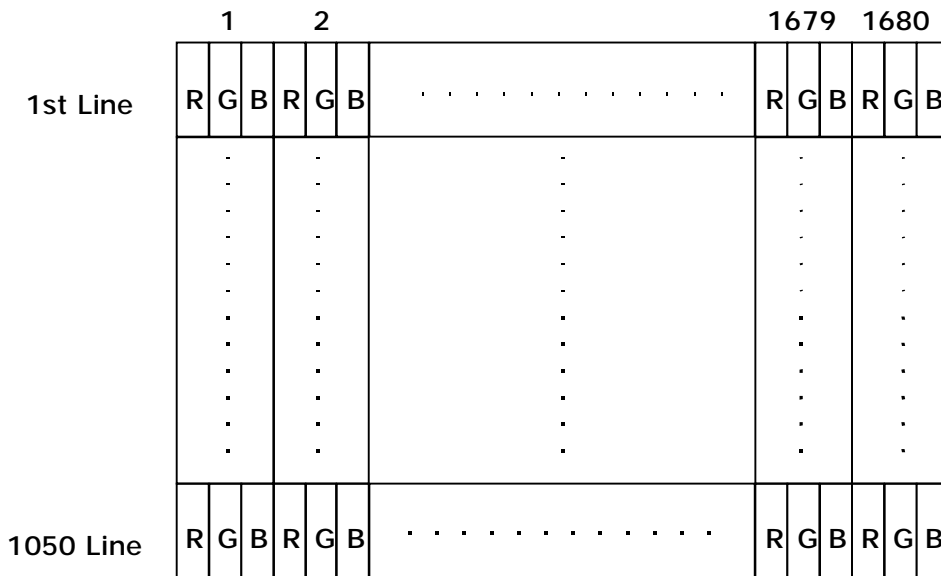

6.2 The input data format

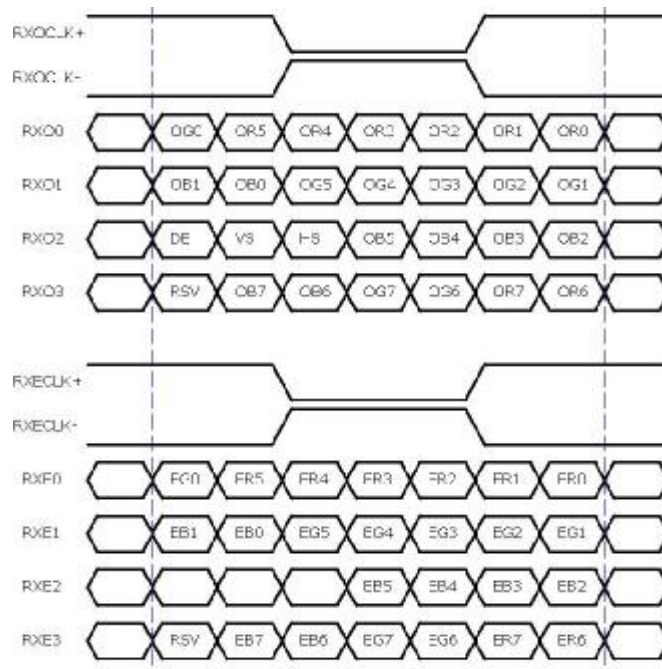

Note 1: R/G/B data 7:MSB, R/G/B data 0:LSB

O = "First Pixel Data"

E = "Second Pixel Data"

6.3 Signal Description

The module using one LVDS receiver SN75LVDS82(Texas Instruments) or compatible. LVDS is a differential signal technology for LCD interface and high speed data transfer device. Transmitter shall be SN75LVDS83(negative edge sampling) or compatible. The first LVDS port(RxOxxx) transmits odd pixels while the second LVDS port(RxExxx) transmits even pixels.

PIN #	SIGNAL NAME	DESCRIPTION
1	RxO0-	Negative LVDS differential data input (Odd data)
2	RxO0+	Positive LVDS differential data input (Odd data)
3	RxO1-	Negative LVDS differential data input (Odd data)
4	RxO1+	Positive LVDS differential data input (Odd data)
5	RxO2-	Negative LVDS differential data input (Odd data, H-Sync,V-Sync,DSPTMG)
6	RxO2+	Positive LVDS differential data input (Odd data, H-Sync,V-Sync,DSPTMG)
7	GND	Power Ground
8	RxOC-	Negative LVDS differential clock input (Odd clock)
9	RxOC+	Positive LVDS differential clock input (Odd clock)
10	RxO3-	Negative LVDS differential data input (Odd data)
11	RxO3+	Positive LVDS differential data input (Odd data)
12	RxE0-	Negative LVDS differential data input (Even clock)
13	RxE0+	Positive LVDS differential data input (Even data)
14	GND	Power Ground
15	RxE1-	Positive LVDS differential data input (Even data)
16	RxE1+	Negative LVDS differential data input (Even data)
17	GND	Power Ground
18	RxE2-	Negative LVDS differential data input (Even data)
19	RxE2+	Positive LVDS differential data input (Even data)
20	RxEC-	Negative LVDS differential clock input (Even clock)
21	RxEC+	Positive LVDS differential clock input (Even clock)
22	RxE3-	Negative LVDS differential data input (Even data)
23	RxE3+	Positive LVDS differential data input (Even data)
24	GND	Power Ground
25	GND	Power Ground
26	NC	No contact (For AUO test only)
27	GND	Power Ground
28	VCC	+5.0V Power Supply
29	VCC	+5.0V Power Supply
30	VCC	+5.0V Power Supply

Note1: Start from left side

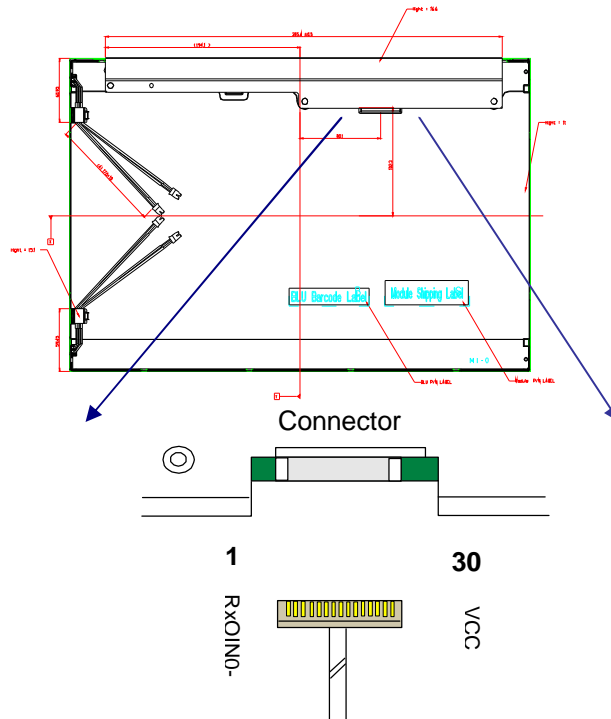

Note2: Input signals of odd and even clock shall be the same timing.

6.4 Timing Characteristics

6.4.1 Timing Characteristics

Basically, interface timings described here is not actual input timing of LCD module but output timing of SN75LVDS82DGG (Texas Instruments) or equivalent.

Signal	Item	Symbol	Min	Typ	Max	Unit
Vertical Section	Period	T_v	1060	1066	2048	Th
	Active	$T_{disp(v)}$	1050	1050	1050	Th
	Blanking	$T_{bp(v)}+T_{fp(v)}+PW_{vs}$	10	16	998	Th
Horizontal Section	Period	T_h	890	1128	2408	Tclk
	Active	$T_{disp(h)}$	840	840	840	Tclk
	Blanking	$T_{bp(h)}+T_{fp(h)}+PW_{hs}$	50	288	1208	Tclk
Clock	Period	T_{clk}	12.5	13.86	16.67	ns
	Frequency	Freq	47.17	72.1	80	MHz
Frame rate	Frame rate	F	50	60	75	Hz

Note : DE mode only

6.4.2 Timing diagram

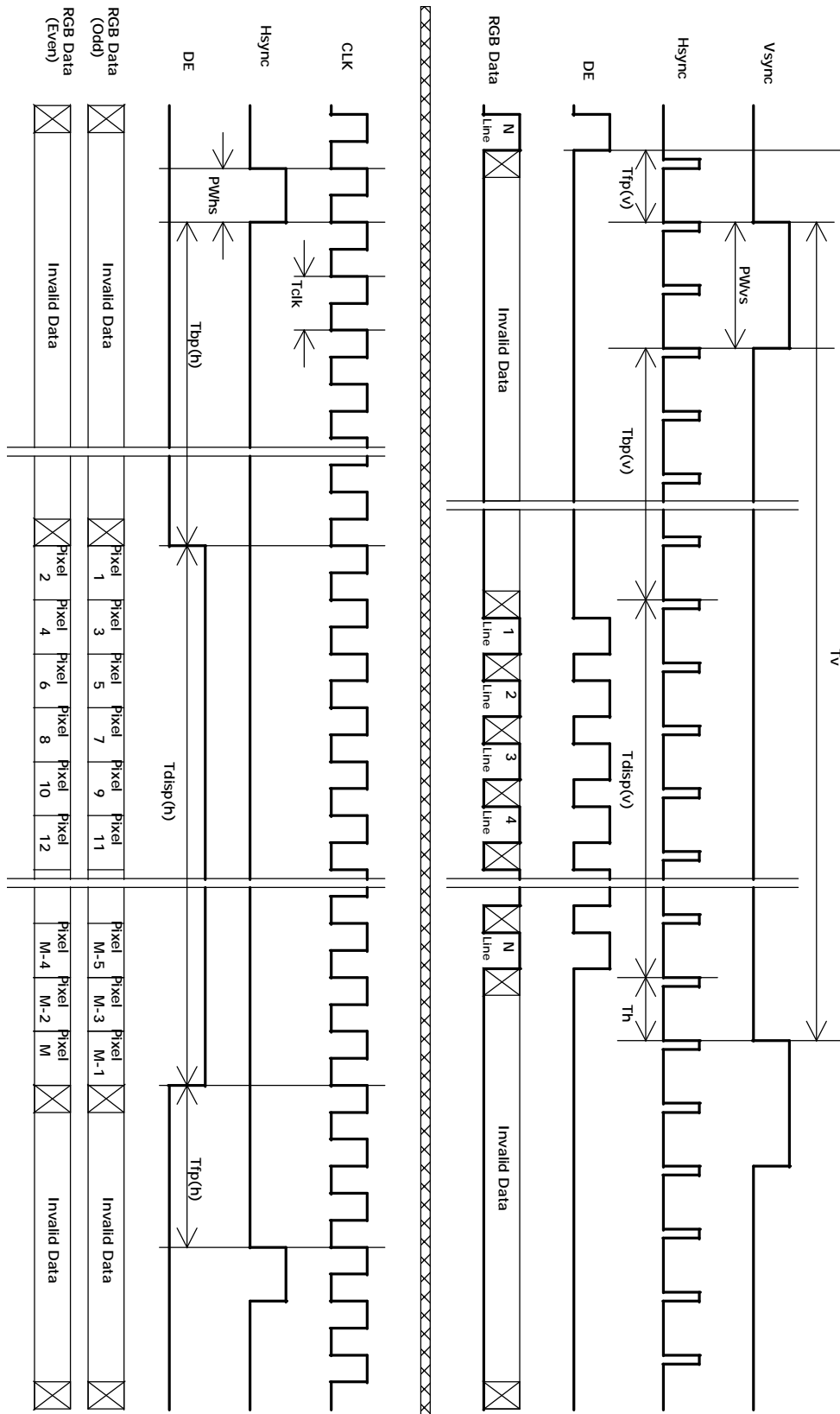

6.5 Power ON/OFF Sequence

Vin power and lamp on/off sequence is as follows. Interface signals are also shown in the chart. Signals from any system shall be Hi-Z state or low level when Vin is off.

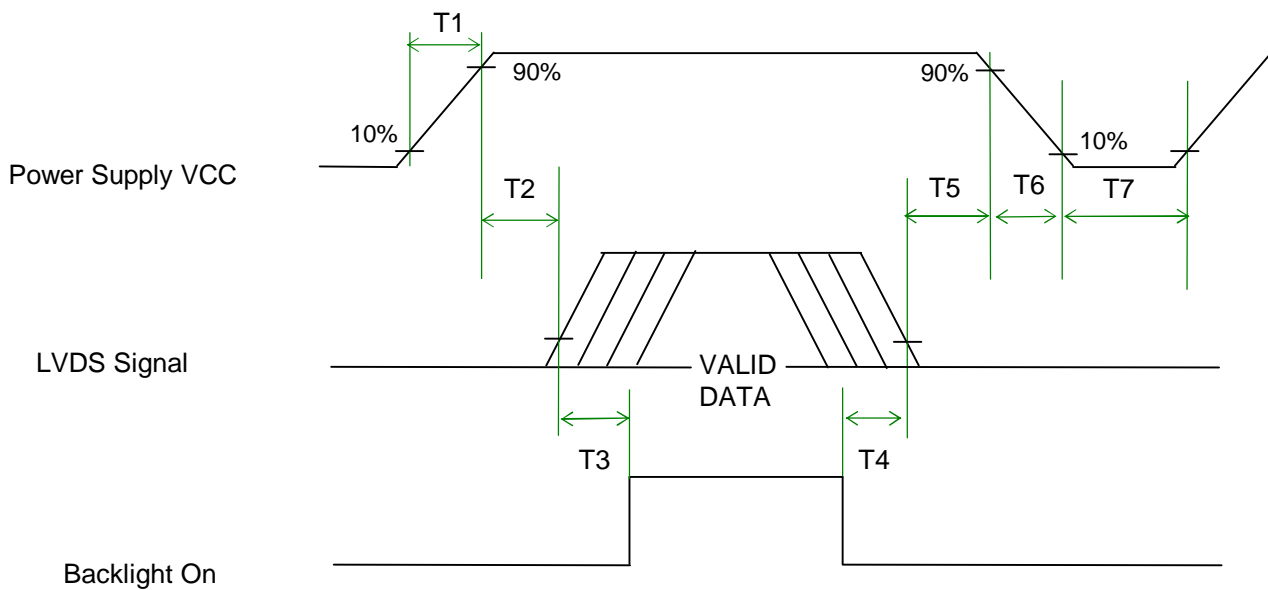

Symbol	Values			Unit
	Min	Typ	Max	
T1	0.5	-	10	[ms]
T2	0.5	40	50	[ms]
T3	300	-	-	[ms]
T4	300	-	-	[ms]
T5	0.5	16	50	[ms]
T6	-	-	100	[ms]
T7	1000	-	-	[ms]

7. Connector & Pin Assignment

Physical interface is described as for the connector on module.

These connectors are capable of accommodating the following signals and will be following components.

7.1 TFT LCD Module

7.1.1 Connector

Connector Name / Designation	Interface Connector / Interface card
Manufacturer	JAE or compatible
Type Part Number	FI-XB30SSRL-HF16
Mating Housing Part Number	FI-X30S-H

7.1.2 Pin Assignment

Pin#	Signal Name	Pin#	Signal Name
1	RxO0-	2	RxO0+
3	RxO1-	4	RxO1+
5	RxO2-	6	RxO2+
7	GND	8	RxOC-
9	RxOC+	10	RxO3-
11	RxO3+	12	RxE0-
13	RxE0+	14	GND
15	RxE1-	16	RxE1+
17	GND	18	RxE2-
19	RxE2+	20	RxEC-
21	RxEC+	22	RxE3-
23	RxE3+	24	GND
25	GND	26	NC
27	GND	28	VCC
29	VCC	30	VCC

7.2 Backlight Unit

Connector Name / Designation	Lamp Connector / Backlight lamp
Manufacturer	YEONHO
Type Part Number	35001HS-02L (CN3/CN4) 35001HS-02L (CN2/CN5)
Mating Type Part Number	SM02B-BHSS-1-TB (2pin)

7.2.1 Signal for Lamp connector

	Connector No.	Pin No.	Color	Function
Upper	CN2	1	Pink	High Voltage (Lamp 1)
		2	White	Low Voltage (Lamp 1)
	CN3	1	Pink	High Voltage (Lamp 2)
		2	White	Low Voltage (Lamp 2)
Upper	CN4	1	Pink	High Voltage (Lamp 3)
		2	White	Low Voltage (Lamp 3)
	CN5	1	Pink	High Voltage (Lamp 4)
		2	White	Low Voltage (Lamp 4)

8. Reliability

Reliability test condition

Items	Required Condition	Note
Temperature Humidity Bias (THB)	Ta= 50°C, 80%RH, 300hours	
High Temperature Operation (HTO)	Ta= 50°C, 50%RH, 300hours	
Low Temperature Operation (LTO)	Ta= 0°C, 300hours	
High Temperature Storage (HTS)	Ta= 60°C, 300hours	
Low Temperature Storage (LTS)	Ta= -20°C, 300hours	
Vibration Test (Non-operation)	Acceleration: 1.5 G Wave: Random Frequency: 10 - 200 - 10 Hz Sweep: 30 Minutes each Axis (X, Y, Z)	
Shock Test (Non-operation)	Acceleration: 50 G Wave: Half-sine Active Time: 20 ms Direction: ±X, ±Y, ±Z (one time for each Axis)	
Drop Test	Height: 60 cm, package test	
Thermal Shock Test (TST)	-20°C/30min, 60°C/30min, 100 cycles	1
On/Off Test	On/10sec, Off/10sec, 30,000 cycles	
ESD (ElectroStatic Discharge)	Contact Discharge: ± 8KV, 150pF(330Ω) 1sec, 8 points, 25 times/ point.	2
	Air Discharge: ± 15KV, 150pF(330Ω) 1sec 8 points, 25 times/ point.	
Altitude Test	Operation:10,000 ft	

Note 1: The TFT-LCD module will not sustain damage after being subjected to 100 cycles of rapid temperature change. A cycle of rapid temperature change consists of varying the temperature from -20°C to 60°C, and back again. Power is not applied during the test. After temperature cycling, the unit is placed in normal room ambient for at least 4 hours before power on.

Note 2: According to EN61000-4-2 , ESD class B: Some performance degradation allowed. No data lost. Self-recoverable. No hardware failures.



9 Shipping Label

The label is on the panel as shown below:

