

NPN Silicon Germanium RF Transistor

Preliminary data

- High gain low noise RF transistor
- Small package 1.4 x 0.8 x 0.59 mm
- Outstanding noise figure $F = 0.7$ dB at 1.8 GHz
Outstanding noise figure $F = 1.3$ dB at 6 GHz
- Maximum stable gain
 $G_{ms} = 21$ dB at 1.8 GHz
 $G_{ma} = 10.5$ dB at 6 GHz
- Gold metallization for extra high reliability

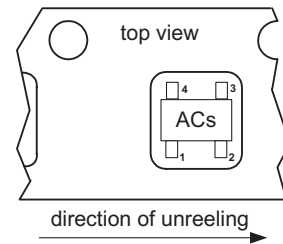
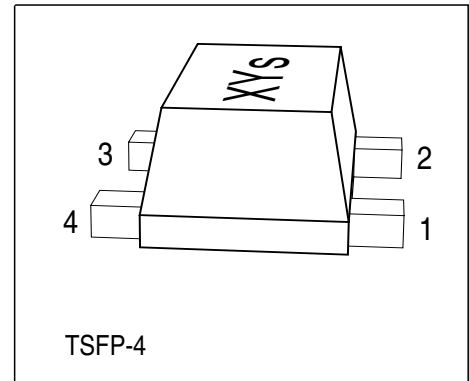

ESD: Electrostatic discharge sensitive device, observe handling precaution!

Type	Marking	Pin Configuration						Package
BFP620F E7764	R2s	1=B	2=E	3=C	4=E	-	-	TSFP-4

Maximum Ratings

Parameter	Symbol	Value	Unit
Collector-emitter voltage	V_{CEO}	2.3	V
Collector-emitter voltage	V_{CES}	7.5	
Collector-base voltage	V_{CBO}	7.5	
Emitter-base voltage	V_{EBO}	1.2	
Collector current	I_C	80	mA
Base current	I_B	3	
Total power dissipation ¹⁾ $T_S \leq 98^\circ\text{C}$	P_{tot}	185	mW
Junction temperature	T_j	150	
Ambient temperature	T_A	-65 ... 150	
Storage temperature	T_{stg}	-65 ... 150	

Thermal Resistance

Parameter	Symbol	Value	Unit
Junction - soldering point ²⁾	R_{thJS}	≤ 280	K/W

¹⁾ T_S is measured on the collector lead at the soldering point to the pcb

²⁾ For calculation of R_{thJA} please refer to Application Note Thermal Resistance

Electrical Characteristics at $T_A = 25^\circ\text{C}$, unless otherwise specified

Parameter	Symbol	Values			Unit
		min.	typ.	max.	
DC Characteristics					
Collector-emitter breakdown voltage $I_C = 1 \text{ mA}, I_B = 0$	$V_{(BR)CEO}$	2.3	2.8	-	V
Collector-emitter cutoff current $V_{CE} = 7.5 \text{ V}, V_{BE} = 0$	I_{CES}	-	-	10	μA
Collector-base cutoff current $V_{CB} = 5 \text{ V}, I_E = 0$	I_{CBO}	-	-	100	nA
Emitter-base cutoff current $V_{EB} = 0.5 \text{ V}, I_C = 0$	I_{EBO}	-	-	3	μA
DC current gain $I_C = 50 \text{ mA}, V_{CE} = 1.5 \text{ V}$	h_{FE}	100	180	320	-

Electrical Characteristics at $T_A = 25^\circ\text{C}$, unless otherwise specified

Parameter	Symbol	Values			Unit
		min.	typ.	max.	
AC Characteristics (verified by random sampling)					
Transition frequency $I_C = 60\text{ mA}$, $V_{CE} = 1.5\text{ V}$, $f = 1\text{ GHz}$	f_T	-	65	-	GHz
Collector-base capacitance $V_{CB} = 2\text{ V}$, $f = 1\text{ MHz}$	C_{cb}	-	0.12	0.2	pF
Collector emitter capacitance $V_{CE} = 2\text{ V}$, $f = 1\text{ MHz}$	C_{ce}	-	0.2	-	
Emitter-base capacitance $V_{EB} = 0.5\text{ V}$, $f = 1\text{ MHz}$	C_{eb}	-	0.45	-	
Noise figure $I_C = 5\text{ mA}$, $V_{CE} = 1.5\text{ V}$, $f = 1.8\text{ GHz}$, $Z_S = Z_{Sopt}$ $I_C = 5\text{ mA}$, $V_{CE} = 1.5\text{ V}$, $f = 6\text{ GHz}$, $Z_S = Z_{Sopt}$	F	-	0.7 1.3	-	dB
Power gain, maximum stable ¹⁾ $I_C = 50\text{ mA}$, $V_{CE} = 1.5\text{ V}$, $Z_S = Z_{Sopt}$, $Z_L = Z_{Lopt}$, $f = 1.8\text{ GHz}$	G_{ms}	-	21	-	dB
Power gain, maximum available ¹⁾ $I_C = 50\text{ mA}$, $V_{CE} = 1.5\text{ V}$, $Z_S = Z_{Sopt}$, $Z_L = Z_{Lopt}$, $f = 6\text{ GHz}$	G_{ma}	-	10.5	-	dB
Transducer gain $I_C = 50\text{ mA}$, $V_{CE} = 1.5\text{ V}$, $Z_S = Z_L = 50\ \Omega$, $f = 1.8\text{ GHz}$ $I_C = 50\text{ mA}$, $V_{CE} = 1.5\text{ V}$, $Z_S = Z_L = 50\ \Omega$, $f = 6\text{ GHz}$	$ S_{21e} ^2$	-	19.5 9	-	dB
Third order intercept point at output ²⁾ $V_{CE} = 2\text{ V}$, $I_C = 50\text{ mA}$, $f = 1.8\text{ GHz}$, $Z_S = Z_L = 50\ \Omega$	IP_3	-	24.5	-	dBm
1dB Compression point at output $I_C = 50\text{ mA}$, $V_{CE} = 2\text{ V}$, $Z_S = Z_L = 50\ \Omega$, $f = 1.8\text{ GHz}$	P_{-1dB}	-	11.5	-	

$$^1 G_{ma} = |S_{21e} / S_{12e}| (k - (k^2 - 1)^{1/2}), G_{ms} = |S_{21e} / S_{12e}|$$

²⁾IP3 value depends on termination of all intermodulation frequency components.
Termination used for this measurement is 50Ω from 0.1 MHz to 6 GHz

SPICE Parameter (Gummel-Poon Model, Berkley-SPICE 2G.6 Syntax):
Transistor Chip Data:

IS =	0.22	fA	BF =	425	-	NF =	1.025	-
VAF =	1000	V	IKF =	0.25	A	ISE =	21	fA
NE =	2	-	BR =	50	-	NR =	1	-
VAR =	2	V	IKR =	10	mA	ISC =	18	pA
NC =	2	-	RB =	3.129	Ω	IRB =	1.522	mA
RBM =	2.707	Ω	RE =	0.6	-	RC =	2.364	Ω
CJE =	250.7	fF	VJE =	0.75	V	MJE =	0.3	-
TF =	1.43	ps	XTF =	10	-	VTF =	1.5	V
ITF =	2.4	A	PTF =	0	deg	CJC =	124.9	fF
VJC =	0.6	V	MJC =	0.5	-	XCJC =	1	-
TR =	0.2	ns	CJS =	128.1	fF	VJS =	0.52	V
MJS =	0.5	-	NK =	-1.42	-	EG =	1.078	eV
XTI =	3	-	FC =	0.8	-	TNOM	298	K
AF =	2	-	KF =	7.291E-11	-			
TITF1	-0.0065	-	TITF2	1.0E-5	-			

All parameters are ready to use, no scaling is necessary.

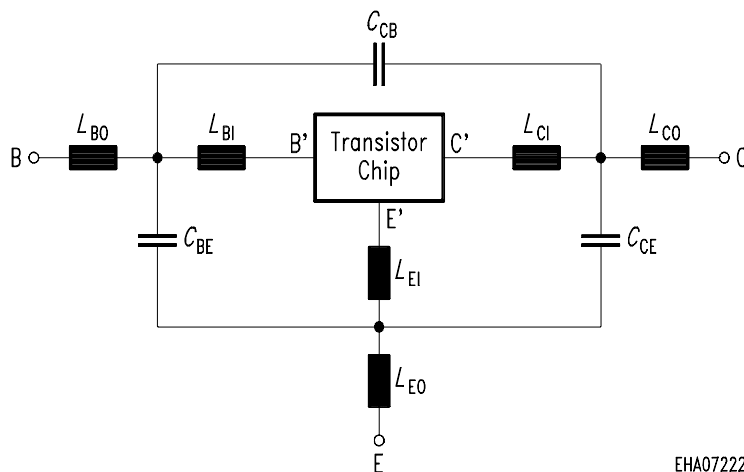
Package Equivalent Circuit:

L_{B0} =	0.22	nH
L_{E0} =	0.28	nH
L_{C0} =	0.22	nH
K_{B0-E0} =	0.1	-
K_{B0-C0} =	0.01	-
K_{E0-C0} =	0.11	-
C_{BE} =	34	fF
C_{BC} =	2	fF
C_{CE} =	33	fF
L_{BI} =	0.42	nH
R_{LBI} =	0.15	Ω
L_{EI} =	0.26	nH
R_{LEI} =	0.11	Ω
L_{CI} =	0.35	nH
R_{LI} =	0.13	Ω
K_{BI-EI} =	-0.05	-
K_{BI-CI} =	-0.08	-
K_{EI-CI} =	0.2	-

To avoid high complexity of the package equivalent circuit, both emitter leads of TSFP-4 are combined in one electrical connection. R_{LxI} are series resistors for the inductances L_{xI} and K_{xa-yb} are the coupling coefficients between the inductances L_{xa} and L_{yb} .

Valid up to 6GHz