



## SP809 / SP810

### 3 Pin Microprocessor Supervisor Circuit

#### FEATURES

- Ultra Low Supply Current 1 $\mu$ A (typ.)
- Guaranteed Reset valid to  $V_{CC} = 0.9V$
- 140 ms Min. Power-On Reset Pulse Width
- Internally Fixed Threshold 2.3V, 2.6V, 2.9V, 3.1V, 4.0V, 4.4V, 4.6V
- Tight Voltage Threshold Tolerance: 1.5%
- Offered in a 3 Pin SOT-23 Package

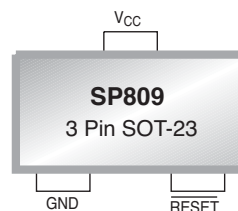

Now Available in Lead Free Packaging

#### APPLICATIONS

- Portable Electronic Devices
- Electrical Power Meter
- Digital Still Camera
- $\mu$ P Power Monitoring

Part Number	Output Type
SP809N	Open-Drain Active Low
SP809	Push-Pull Active Low
SP810	Push-Pull Active High

#### DESCRIPTION

The SP809/SP810 are low power microprocessor ( $\mu$ P) supervisory circuits used to monitor power supplies in  $\mu$ P and digital systems. They provide applications with benefits of circuit reliability and low cost by eliminating external components. If the  $V_{CC}$  supply voltage falls below preset threshold then a reset signal is asserted for at least 140ms after  $V_{CC}$  has risen above the reset threshold. Both the SP809 and SP810 were designed with a reset comparator to help identify invalid signals, which last less than 140ms. The only difference between them is that they have an active-low  $\overline{RESET}$  output and active-high RESET output, respectively. Low supply current (1 $\mu$ A) makes SP809/SP810 ideal for portable equipment. The devices are available in 3 pin SOT-23 package.

#### TYPICAL APPLICATION CIRCUIT

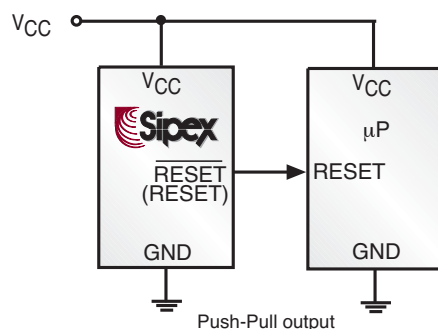

$V_{CC}$  ..... -0.3V to 6.5V  
 RESET, RESET ..... -0.3 to  $V_{CC} + 0.3V$   
 Input Current ( $V_{CC}$ ) ..... 20mA  
 Output Current (RESET, RESET) ..... 20mA  
 Continuous Power Dissipation ( $T_A = +70^\circ C$ ) ..... 320mW  
 Operating Junction Temperature ..... -40°C to +85°C  
 Junction Temperature ..... 125°C

Storage Temperature ..... -65°C to +150°C

These are stress ratings only and functional operation of the device at these ratings or any other above those indicated in the operation sections of the specifications below is not implied. Exposure to absolute maximum rating conditions for extended periods of time may affect reliability.

## ABSOLUTE MAXIMUM RATINGS

## ELECTRICAL CHARACTERISTICS

Typical values are at  $T_A = 25^\circ C$ , unless otherwise specified. (Note 1)

Parameter	Symbol	Min.	Typ.	Max.	Units	Conditions	
Operating Voltage Range	$V_{CC}$	0.9		6.0	V		
Supply Current	$I_{CC}$		1.0	3.0	$\mu A$	$V_{CC} = V_{TH} + 0.1V$	
Reset Threshold	$V_{TH}$	2.265	2.3	2.335	V	SP809-23	$T_A = +25^\circ C$
		2.254		2.346			$T_A = -40^\circ C$ to + 85°C
		2.561	2.6	2.639		SP809-26	$T_A = +25^\circ C$
		2.548		2.652			$T_A = -40^\circ C$ to + 85°C
		2.857	2.9	2.944		SP809-29	$T_A = +25^\circ C$
		2.842		2.958			$T_A = -40^\circ C$ to + 85°C
		3.054	3.1	3.147		SP809-31	$T_A = +25^\circ C$
		3.038		3.162			$T_A = -40^\circ C$ to + 85°C
		3.940	4.0	4.060		SP809-40	$T_A = +25^\circ C$
		3.920		4.080			$T_A = -40^\circ C$ to + 85°C
		4.334	4.4	4.466		SP809-44	$T_A = +25^\circ C$
		4.312		4.488			$T_A = -40^\circ C$ to + 85°C
		4.531	4.6	4.669		SP809-46	$T_A = +25^\circ C$
		4.508		4.692			$T_A = -40^\circ C$ to + 85°C
$V_{CC}$ Reset Delay	$V_{TRIP}$		20		$\mu S$	$V_{CC} = V_{TH}$ to $(V_{TH} - 0.1V)$ , $V_{TH} = 3.1V$	
Reset Active Timeout Period	$T_{RP}$	140	230	560	ms	$V_{CC} = V_{TH(MAX)}$	$T_A = +25^\circ C$
		100		1030			$T_A = -40^\circ C$ to + 85°C
RESET Output Voltage	$V_{OH}$	0.8 $V_{CC}$			V	$V_{CC} = V_{TH} - 0.1V$ , $I_{SOURCE} = 1.2mA$	
	$V_{OL}$			0.3			$V_{CC} = V_{TH} + 0.1V$ , $I_{SINK} = 1.2mA$
RESET Output Voltage	$V_{OH}$	0.8 $V_{CC}$			V	$V_{CC} = V_{TH} + 0.1V$ , $I_{SOURCE} = 1.2mA$	
	$V_{OL}$			0.3			$V_{CC} = V_{TH} - 0.1V$ , $I_{SINK} = 1.2mA$

## ELECTRICAL CHARACTERISTICS

Note 1. Specifications are production tested at  $T_A = 25^\circ\text{C}$ . Specifications over the  $-40^\circ\text{C}$  to  $85^\circ\text{C}$  operating temperature range are assured by design, characterization and correlation with Statistical Quality Controls

Note 2.  $\overline{\text{RESET}}$  output is for SP809; RESET output is for SP810.

## BLOCK DIAGRAMS

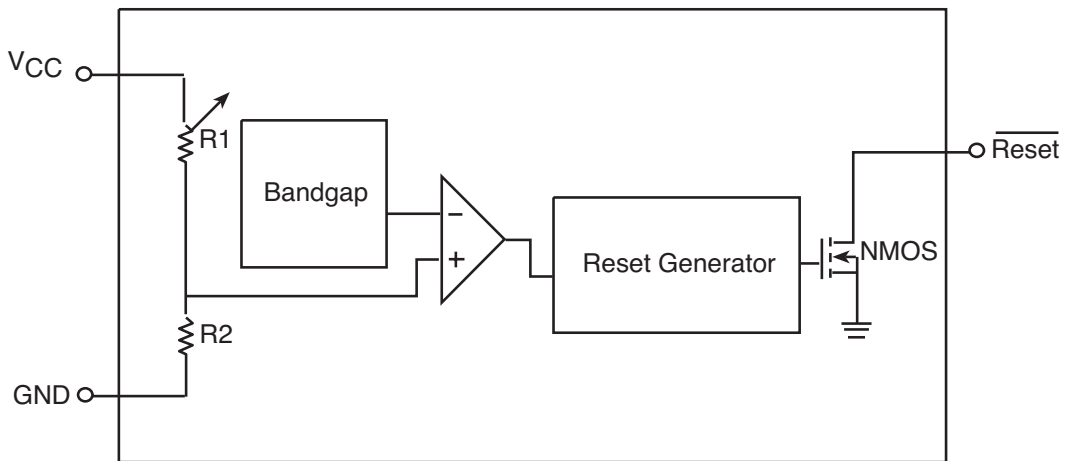

*N-ch Open-Drain Type*

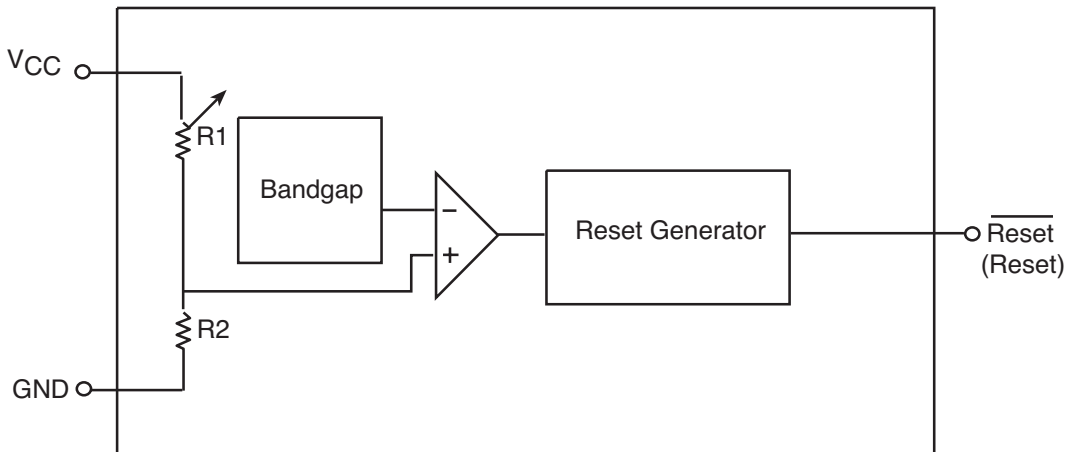

*Push-Pull Type*

## TEST CIRCUIT

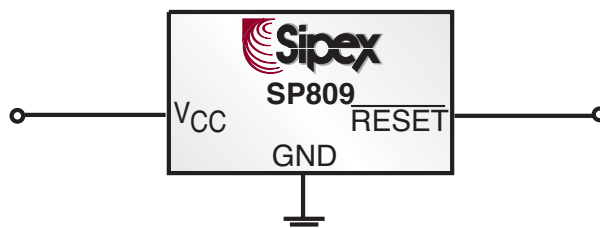

## TYPICAL PERFORMANCE CHARACTERISTICS

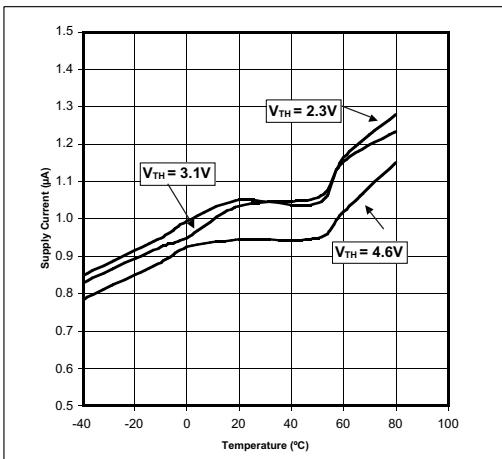

Figure 1. Supply Current vs. Temperature

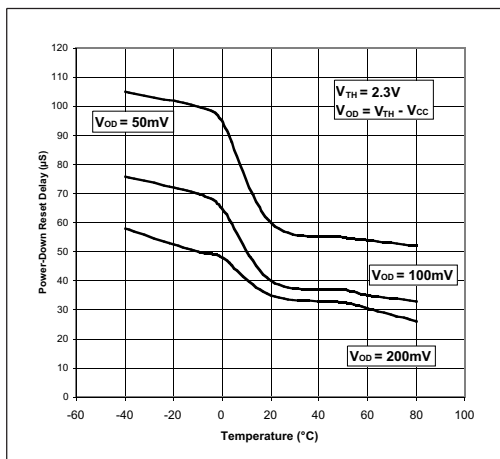

Figure 2. Power-Down Reset Delay vs. Temperature

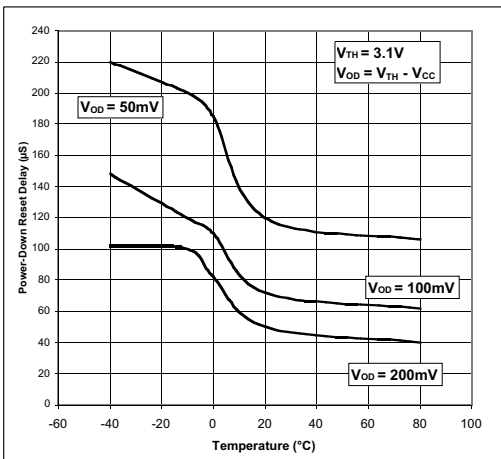

Figure 3. Power-Down Reset Delay vs. Temperature

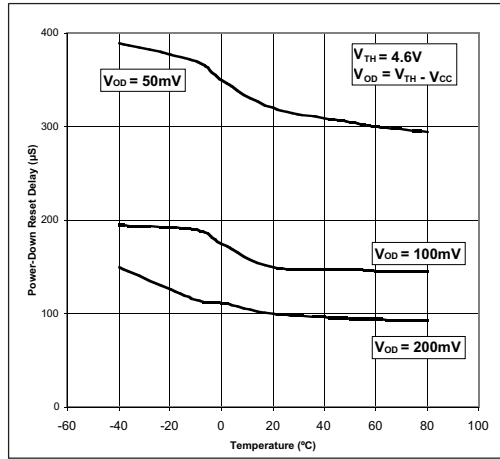

Figure 4. Power-Down Reset Delay vs. Temperature

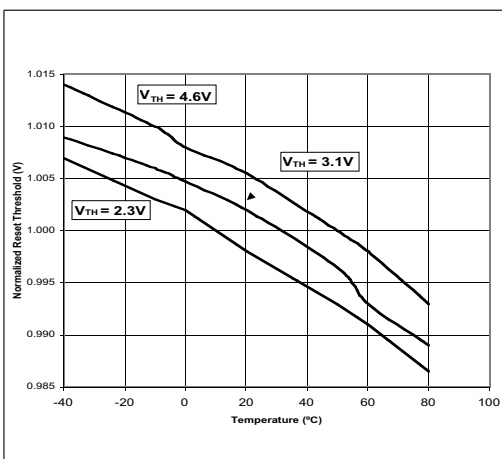

Figure 5. Normalized Reset Threshold vs. Temperature

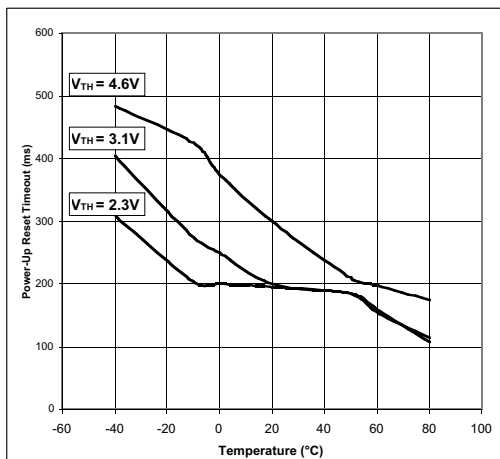

Figure 6. Power-Up Reset Time-out vs. Temperature

## PIN DESCRIPTION

Pin Name	Description
GND	Ground.
RESET (SP809)	Active low output pin. RESET Output remains low while VCC is below the reset threshold.
RESET (SP810)	Active high output pin. RESET Output remains high while VCC is below the reset threshold.
V <sub>CC</sub>	Supply Voltage

## DETAILED DESCRIPTION

μP will be activated at a valid reset state. These μP supervisory circuits assert reset to prevent code execution errors during power-up, power-down, or brownout conditions.

Reset is guaranteed to be a logic low for  $V_{TH} > V_{CC} > 0.9V$ . Once  $V_{CC}$  exceeded the reset threshold, an internal timer keeps RESET low for the reset timeout period; after this interval, RESET goes high.

If a brownout condition occurs ( $V_{CC}$  drops below the reset threshold), RESET goes low. Any time  $V_{CC}$  goes below the reset threshold, the internal timer resets to zero, and RESET goes low. The internal timer is activated after  $V_{CC}$  returns above the reset threshold, and RESET remains low for the reset timeout period.

### Benefits of Highly Accurate Reset Threshold

SP809/810 with specified voltage as  $5V \pm 10\%$  or  $3V \pm 10\%$  are ideal for systems using a  $5V \pm 5\%$  or  $3V \pm 5\%$  power supply. The reset is guaranteed to assert after the power supply falls below the minimum specified operating voltage range of the system ICs. The pretrimmed thresholds are reducing the range over which an undesirable reset may occur.

## APPLICATION INFORMATION

### Negative-Going V<sub>CC</sub> Transients

In addition to issuing a reset to the μP during power-up, power-down, and brownout conditions, SP809 series are relatively resistant to short-duration negative-going V<sub>CC</sub> transient.

### Ensuring a Valid Reset Output Down to VCC= 0

When  $V_{CC}$  falls below 0.9V, SP809 RESET output no longer sinks current; it becomes an open circuit. In this case, high-impedance CMOS logic inputs connecting to RESET can drift to undetermined voltages. Therefore, SP809/810 with CMOS is perfect for most applications of V<sub>CC</sub> down to 0.9V.

However in applications where RESET must be valid down to 0V, adding a pull-down resistor to RESET causes any leakage currents to flow to ground, holding RESET low.

### Interfacing to μP with Bidirectional Reset Pins

The RESET output on the SP809N is open drain, this device interfaces easily with μPs that have bidirectional reset pins. Connecting the μP supervisor's RESET output directly to the microcontroller's RESET pin with a single pull-up resistor allows either device to assert reset.

**PACKAGE: 3 PIN SOT-23**

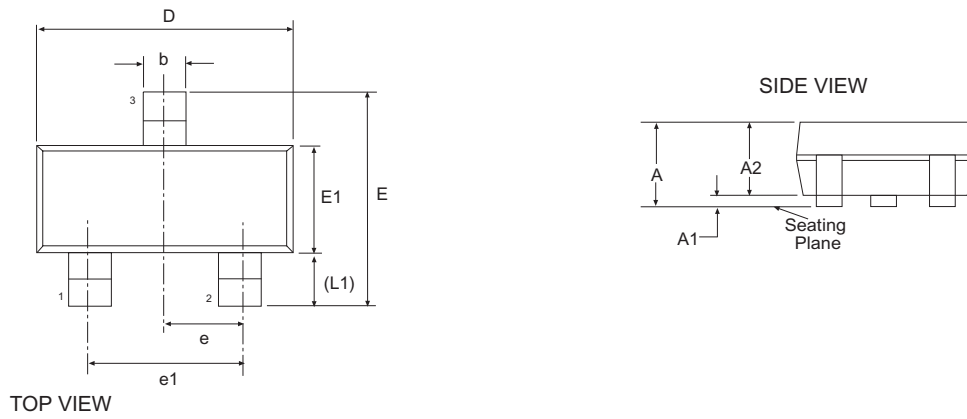

3 Pin SOT-23		JEDEC TO-236		Variation AB		
SYMBOL	Dimensions in Millimeters: Controlling Dimension			Dimensions in Inches Conversion Factor: 1 Inch = 25.40 mm		
	MIN	NOM	MAX	MIN	NOM	MAX
b	0.30	-	0.50	0.012	-	0.020
c	0.08	-	0.20	0.003	-	0.008
D	2.80	2.90	3.04	0.110	0.114	0.120
E	2.10	-	2.64	0.083	-	0.104
E1	1.20	1.30	1.40	0.047	0.051	0.055
e	0.95 BSC			0.038 BSC		
e1	1.90 BSC			0.075 BSC		
L	0.40	0.50	0.60	0.016	0.020	0.024
L1	0.54 REF			0.021 REF		
L2	0.25 BSC			0.010 BSC		
∅	0°	-	8°	0°	-	8°
A	0.89	-	1.12	0.035	-	0.044
A1	0.01	-	0.10	0.000	-	0.004
A2	0.88	0.95	1.02	0.035	0.037	0.040
SIPEX Pkg Signoff Date/Rev:				JL Oct25-05 / Rev A		

## ORDERING INFORMATION

Part Number	Top Mark	Temperature Range	Package Type
SP809EK-2-3	N4WW	-40°C to 85°C	3 Pin SOT-23
SP809EK-2-3/TR	N4WW	-40°C to 85°C	3 Pin SOT-23
SP809EK-2-6	P4WW	-40°C to 85°C	3 Pin SOT-23
SP809EK-2-6/TR	P4WW	-40°C to 85°C	3 Pin SOT-23
SP809EK-2-9	Q4WW	-40°C to 85°C	3 Pin SOT-23
SP809EK-2-9/TR	Q4WW	-40°C to 85°C	3 Pin SOT-23
SP809EK-3-1	R4WW	-40°C to 85°C	3 Pin SOT-23
SP809EK-3-1/TR	R4WW	-40°C to 85°C	3 Pin SOT-23
SP809EK-4-0	S4WW	-40°C to 85°C	3 Pin SOT-23
SP809EK-4-0/TR	S4WW	-40°C to 85°C	3 Pin SOT-23
SP809EK-4-4	T4WW	-40°C to 85°C	3 Pin SOT-23
SP809EK-4-4/TR	T4WW	-40°C to 85°C	3 Pin SOT-23
SP809EK-4-6	U4WW	-40°C to 85°C	3 Pin SOT-23
SP809EK-4-6/TR	U4WW	-40°C to 85°C	3 Pin SOT-23
SP809NEK-2-3	V4WW	-40°C to 85°C	3 Pin SOT-23
SP809NEK-2-3/TR	V4WW	-40°C to 85°C	3 Pin SOT-23
SP809NEK-2-6	W4WW	-40°C to 85°C	3 Pin SOT-23
SP809NEK-2-6/TR	W4WW	-40°C to 85°C	3 Pin SOT-23
SP809NEK-2-9	X4WW	-40°C to 85°C	3 Pin SOT-23
SP809NEK-2-9/TR	X4WW	-40°C to 85°C	3 Pin SOT-23
SP809NEK-3-1	Y4WW	-40°C to 85°C	3 Pin SOT-23
SP809NEK-3-1/TR	Y4WW	-40°C to 85°C	3 Pin SOT-23
SP809NEK-4-0	A5WW	-40°C to 85°C	3 Pin SOT-23
SP809NEK-4-0/TR	A5WW	-40°C to 85°C	3 Pin SOT-23
SP809NEK-4-4	B5WW	-40°C to 85°C	3 Pin SOT-23
SP809NEK-4-4/TR	B5WW	-40°C to 85°C	3 Pin SOT-23
SP809NEK-4-6	C5WW	-40°C to 85°C	3 Pin SOT-23
SP809NEK-4-6/TR	C5WW	-40°C to 85°C	3 Pin SOT-23

Available in lead free packaging. To order add "-L" suffix to part number.

Example: SP809EK-2-3/TR = standard; SP809EK-L-2-3/TR = lead free

/TR = Tape and Reel

Pack quantity is 2,500 for SOT-23.



Solved By Sipex™

**Sipex Corporation**

**Headquarters and  
Sales Office**  
233 South Hillview Drive  
Milpitas, CA 95035  
TEL: (408) 934-7500  
FAX: (408) 935-7600

Sipex Corporation reserves the right to make changes to any products described herein. Sipex does not assume any liability arising out of the application or use of any product or circuit described herein; neither does it convey any license under its patent rights nor the rights of others.

---

## ORDERING INFORMATION

Part Number	Top Mark	Temperature Range	Package Type
SP810EK-2-3	D5WW	-40°C to 85°C	3 Pin SOT-23
SP810EK-2-3/TR	D5WW	-40°C to 85°C	3 Pin SOT-23
SP810EK-2-6	E5WW	-40°C to 85°C	3 Pin SOT-23
SP810EK-2-6/TR	E5WW	-40°C to 85°C	3 Pin SOT-23
SP810EK-2-9	F5WW	-40°C to 85°C	3 Pin SOT-23
SP810EK-2-9/TR	F5WW	-40°C to 85°C	3 Pin SOT-23
SP810EK-3-1	G5WW	-40°C to 85°C	3 Pin SOT-23
SP810EK-3-1/TR	G5WW	-40°C to 85°C	3 Pin SOT-23
SP810EK-4-0	H5WW	-40°C to 85°C	3 Pin SOT-23
SP810EK-4-0/TR	H5WW	-40°C to 85°C	3 Pin SOT-23
SP810EK-4-4	J5WW	-40°C to 85°C	3 Pin SOT-23
SP810EK-4-4/TR	J5WW	-40°C to 85°C	3 Pin SOT-23
SP810EK-4-6	K5WW	-40°C to 85°C	3 Pin SOT-23
SP810EK-4-6/TR	K5WW	-40°C to 85°C	3 Pin SOT-23

Available in lead free packaging. To order add "-L" suffix to part number.

Example: SP810EK-2-3/TR = standard; SP810EK-L-2-3/TR = lead free

/TR = Tape and Reel

Pack quantity is 2,500 for SOT-23.



Solved By Sipex™

### Sipex Corporation

**Headquarters and  
Sales Office**  
233 South Hillview Drive  
Milpitas, CA 95035  
TEL: (408) 934-7500  
FAX: (408) 935-7600

Sipex Corporation reserves the right to make changes to any products described herein. Sipex does not assume any liability arising out of the application or use of any product or circuit described herein; neither does it convey any license under its patent rights nor the rights of others.