

### General Description

The AAT3143 is a low noise, constant frequency charge pump DC/DC converter that uses a tri-mode load switch (1X), fractional (1.5X), and doubling (2X) conversion to maximize efficiency for white LED applications. The AAT3143 can deliver current levels up to 80mA to drive white LEDs connected to the four current source outputs from a 2.7V to 5.5V input. The current source outputs may source up to 20mA each and may be operated individually or in parallel for driving higher-current LEDs. A low external parts count (two 1µF flying capacitors and two small 1µF capacitors at  $V_{IN}$  and  $V_{OUT}$ ) makes the AAT3143 ideally suited for small battery-powered applications.

Output current, and therefore brightness, is controlled via externally applied Pulse Width Modulation (PWM) control. Typically, PWM frequencies of up to 50kHz can be applied.

The AAT3143 has a thermal management system to protect the device in the event of a short-circuit condition at the voltage output pin. Built-in soft-start circuitry prevents excessive inrush current during start-up. A high charge pump switching frequency allows the use of very small external capacitors. A low current shutdown feature disconnects the load from  $V_{IN}$  and reduces quiescent current to less than 1µA.

The AAT3143 is available in a Pb-free, space-saving, 2.85x3.0mm 12-pin TSOPJW package.

### Features

- Input Voltage Range: 2.7V to 5.5V
- PWM Brightness Control
- Tri-Mode 1X, 1.5X, and 2X Charge Pump for Maximum Efficiency and  $V_F$  Coverage
- Drives Four Low- or High- $V_F$  Type LEDs
- Up to 20mA LED Current per Channel
- No Inductors
- 1MHz Switching Frequency
- Small Application Circuit
- AutoBias™ Technology
- $I_Q < 1\mu A$  in Shutdown
- 2.85x3.0mm TSOPJW-12 Package

### Applications

- Programmable Current Sources
- White LED Backlighting
- White Photo Flash for Digital Still Cameras

### Typical Application

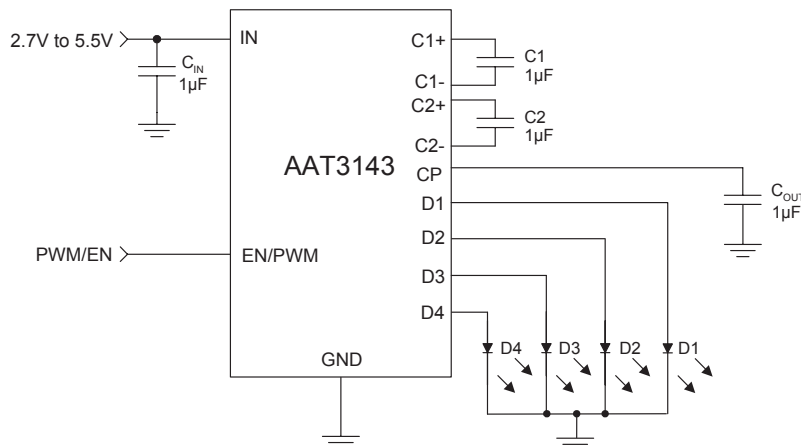

### Pin Descriptions

Pin #	Symbol	Function
1	C2+	Flying capacitor 2 positive terminal. Connect a 1 $\mu$ F capacitor between C2+ and C2-.
2	CP	Charge pump output. Requires 1 $\mu$ F capacitor connected between this pin and ground.
3	C1-	Flying capacitor 1 negative terminal.
4	C1+	Flying capacitor 1 positive terminal. Connect a 1 $\mu$ F capacitor between C1+ and C1-.
5	D3	Current source output #3.
6	D2	Current source output #2.
7	D4	Current source output #4.
8	D1	Current source output #1.
9	EN/PWM	Enable/PWM control pin.
10	IN	Input power supply. Requires 1 $\mu$ F capacitor connected between this pin and ground.
11	GND	Ground.
12	C2-	Flying capacitor 2 negative terminal.

### Pin Configuration

**TSOPJW-12  
(Top View)**

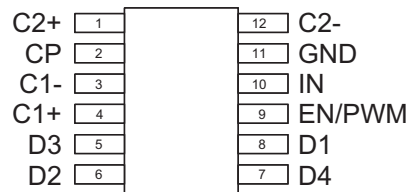

### Absolute Maximum Ratings<sup>1</sup>

Symbol	Description	Value	Units
$V_{IN}$	Input Voltage	-0.3 to 6	V
$V_{EN/PWM}$	EN/PWM to GND Voltage	-0.3 to $V_{IN} + 0.3$	V
$I_{OUT}^2$	Maximum DC Output Current	80	mA
$T_J$	Operating Junction Temperature Range	-40 to 150	°C
$T_{LEAD}$	Maximum Soldering Temperature (at leads, 10 sec)	300	°C

### Thermal Information<sup>3</sup>

Symbol	Description	Value	Units
$P_D$	Maximum Power Dissipation <sup>4</sup>	0.625	W
$\theta_{JA}$	Maximum Thermal Resistance	160	°C/W

1. Stresses above those listed in Absolute Maximum Ratings may cause permanent damage to the device. Functional operation at conditions other than the operating conditions specified is not implied. Only one Absolute Maximum Rating should be applied at any one time.
2. Based on long-term current density limitation.
3. Mounted on an FR4 board.
4. Derate 6.25 mW/°C above 25°C.

### Electrical Characteristics<sup>1</sup>

$C_{IN} = C_{CP} = C_1 = C_2 = 1.0\mu\text{F}$ ;  $T_A = -40^\circ\text{C}$  to  $+85^\circ\text{C}$ , unless otherwise noted. Typical values are  $T_A = 25^\circ\text{C}$ ,  $V_{IN} = 3.5\text{V}$ .

Symbol	Description	Conditions	Min	Typ	Max	Units
<b>Input Power Supply</b>						
$V_{IN}$	Operation Range		2.7		5.5	V
$I_{CC}$	Operating Current	VD1:D4 = 2.0V, CP = 1X		550		$\mu\text{A}$
		No Load Current, CP = 1.5X		3	5	
$I_{SHDN}$	Shutdown Current	EN/PWM = 0			1	$\mu\text{A}$
$I_{DX}$	Output Current Accuracy	$I_{OUT} = 20\text{mA}$ , $T_A = 25^\circ\text{C}$ , $V_{IN} = 3.5\text{V}$	18	20	22	mA
$I_{(D-Match)}$	Current Matching <sup>2</sup>	VD1:D4 = 3.6V, $V_{IN} = 3.5\text{V}$	-3	$\pm 0.5$	3	%
$\eta_{CP}$	Charge Pump Efficiency	$V_{IN} = 3.5\text{V}$ , $I_{OUT(TOTAL)} = 80\text{mA}$ , Measured from IN to CP		93		%
<b>Charge Pump Section</b>						
$F_{CLK}$	Clock Frequency			1000		kHz
<b>EN/PWM</b>						
$V_{EN(L)}$	Enable Threshold Low				0.4	V
$V_{EN(H)}$	Enable Threshold High		1.4			V
$F_{PWM}$	Maximum PWM Frequency			50		kHz
$t_{ON(MIN)}$	Minimum Pulse Width			2		$\mu\text{s}$

1. The AAT3143 is guaranteed to meet performance specifications over the  $-40^\circ\text{C}$  to  $+85^\circ\text{C}$  operating temperature range and is assured by design, characterization, and correlation with statistical process controls.  
 2. Current matching is defined as  $I_{(D-Match)} = (I_D - I_{AVE})/I_{AVE}$ .

### Typical Characteristics

$V_{IN} = 3.5V$ ,  $C_{IN} = C_{CP} = C_1 = C_2 = 1\mu F$ ,  $T_A = 25^\circ C$ , unless otherwise noted.

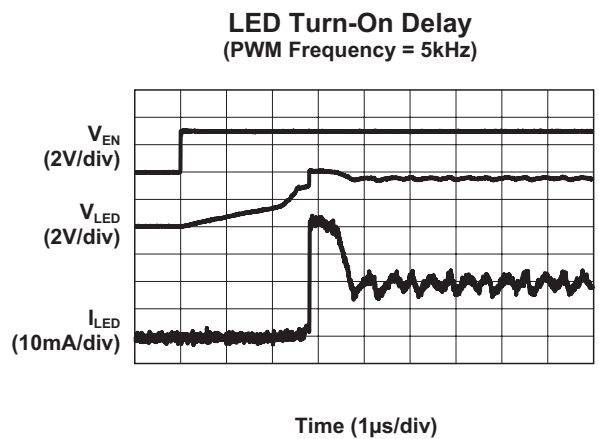
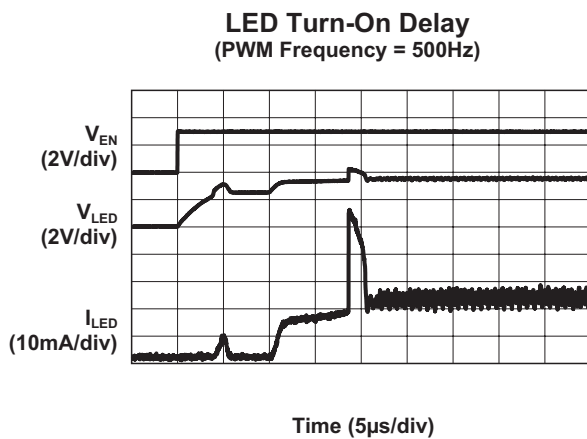
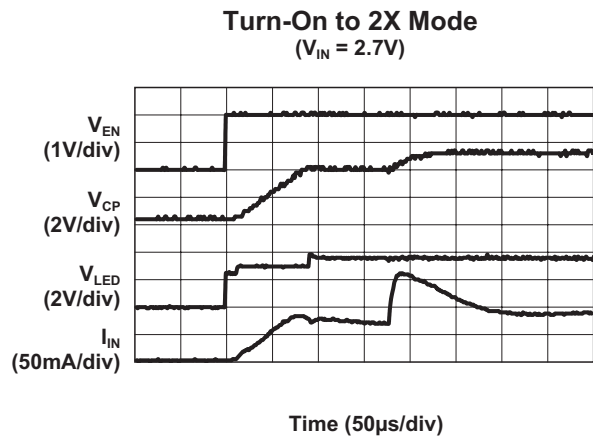
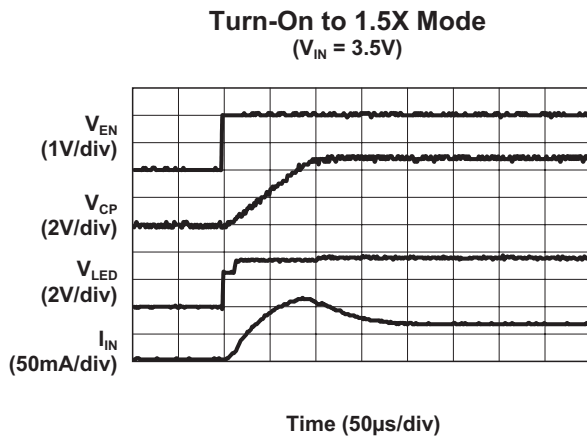
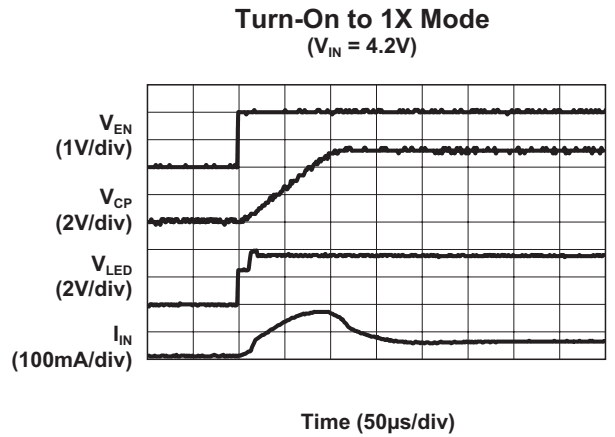
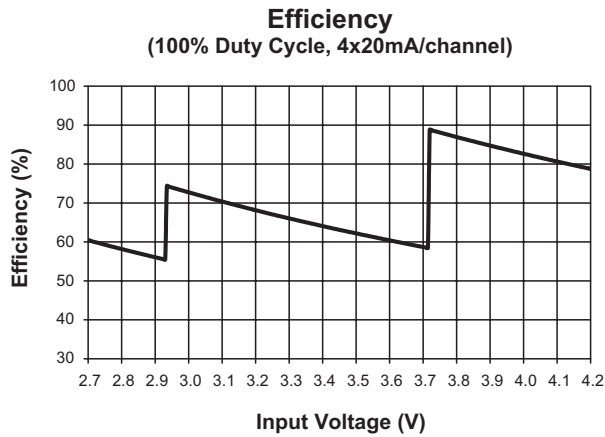

### Typical Characteristics

$V_{IN} = 3.5V$ ,  $C_{IN} = C_{CP} = C_1 = C_2 = 1\mu F$ ,  $T_A = 25^\circ C$ , unless otherwise noted.

**1.5X Mode PWM Characteristic**  
(5kHz at 50% Duty Cycle)

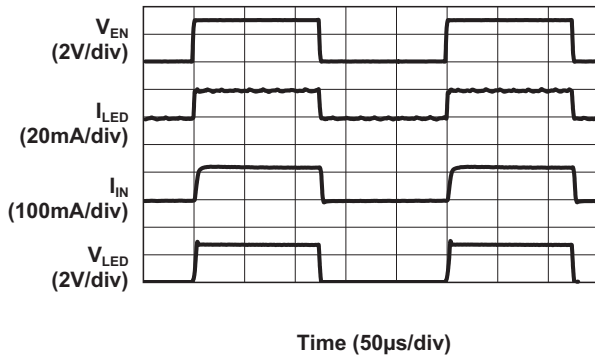

**PWM Duty Cycle vs. LED Current**

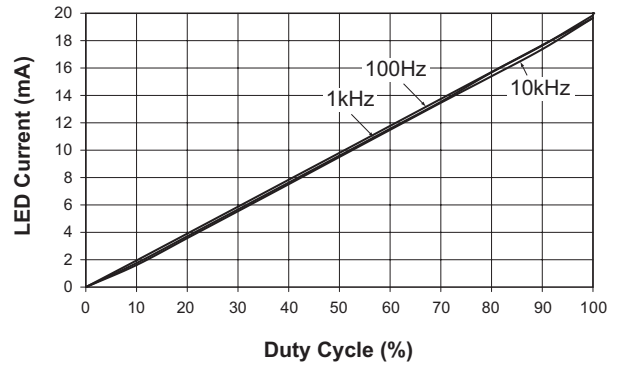

**Line Response**  
(1X Mode, 4x19mA Load)

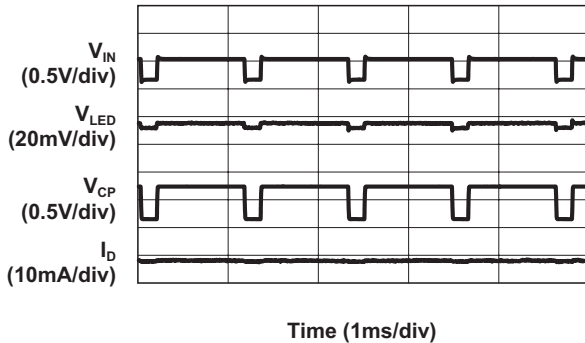

**Line Response**  
(1.5X Mode, 4x19mA Load)

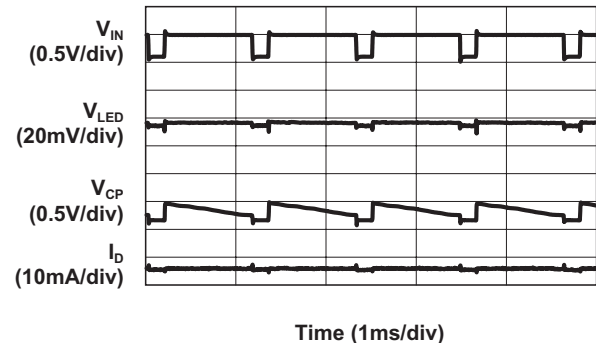

**Load Characteristics**  
(1.5X Mode, 4x15mA Load)

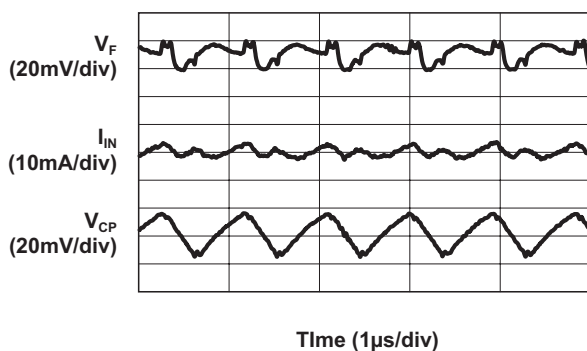

**Input Current vs. Input Voltage**  
(4x10mA)

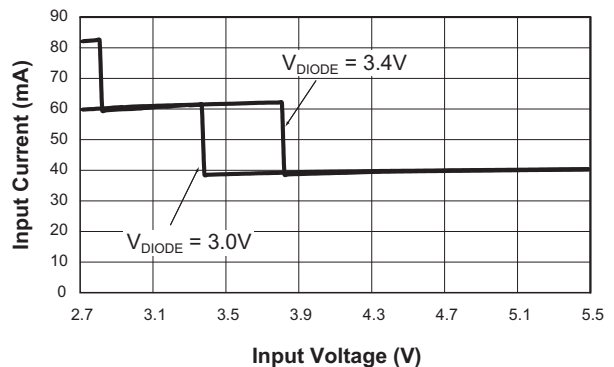

### Typical Characteristics

$V_{IN} = 3.5V$ ,  $C_{IN} = C_{CP} = C_1 = C_2 = 1\mu F$ ,  $T_A = 25^\circ C$ , unless otherwise noted.

$V_{IH}$  and  $V_{IL}$  vs.  $V_{IN}$

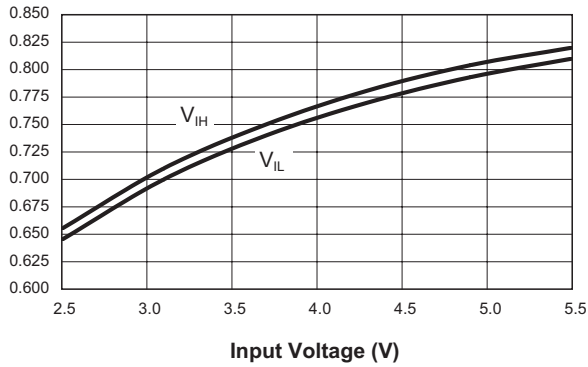

### Functional Block Diagram

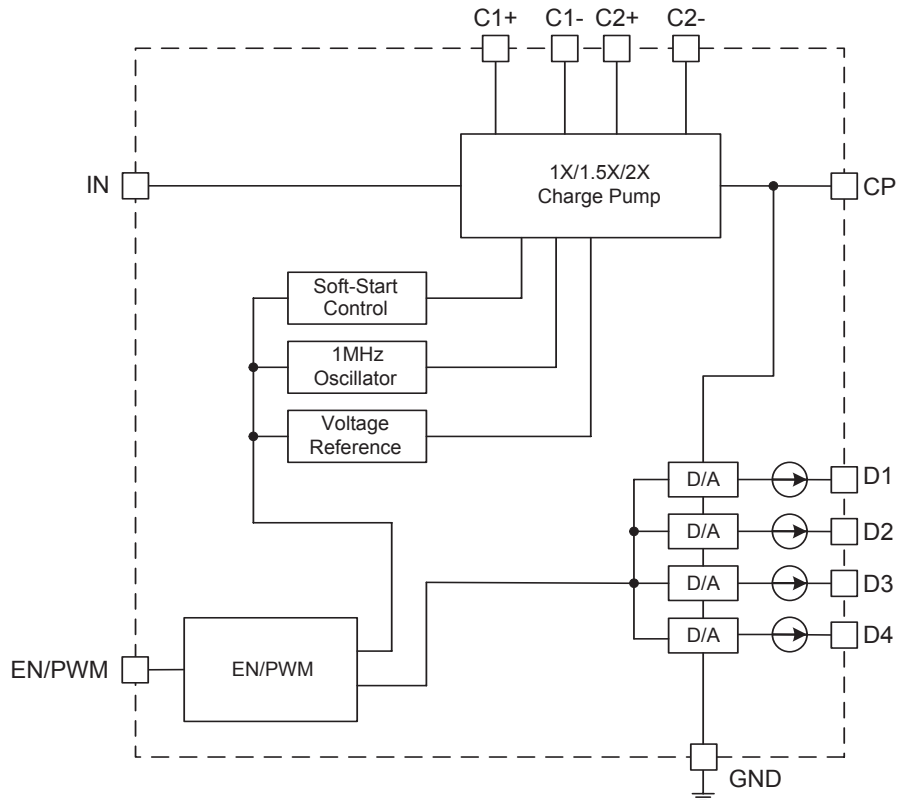

### Functional Description

The AAT3143 is a tri-mode load switch (1X) and high efficiency (1.5X or 2X) charge pump device intended for white LED backlight applications. To maximize power conversion efficiency, an internal sensing circuit monitors the voltage required on each constant current source output and sets the load switch and charge pump modes based on the input battery voltage and the current source output voltage. As the battery discharges over time, the AAT3143 charge pump is enabled when any of the four current source outputs nears dropout. The charge pump initially starts in 1.5X mode. If the charge pump output drops enough for any current

source output to become close to dropout, the charge pump will automatically transition to 2X mode. The AAT3143 requires only four external components: two 1 $\mu$ F ceramic capacitors for the charge pump flying capacitors ( $C_1$  and  $C_2$ ), one 1 $\mu$ F ceramic input capacitor ( $C_{IN}$ ), and one 0.33 $\mu$ F to 1 $\mu$ F ceramic charge pump output capacitor ( $C_{OUT}$ ).

The four constant current source outputs (D1 to D4) can drive four individual LEDs with a maximum current of 20mA each. The unused source outputs must be connected to GND, otherwise the part will operate only in 2X charge pump mode. The EN/PWM input allows the user to control the brightness of the four LEDs by PWMing up to 50kHz.



## Applications Information

### EN/PWM Dimming Control

LED brightness is controlled with the EN/PWM pin. By driving the pin with a PWM signal, a corresponding pulse-width modulated current will be driven through the LEDs. In this way, the duty cycle sets the LED brightness level. The resulting average current that flows through the LED is calculated as follows:

$$I_{LED} = DC \cdot 20mA$$

The EN/PWM pin can be driven with a wide range of PWM frequencies. Because of the short turn-on delay during high frequency PWM, a frequency as high as 50kHz can be used. A low PWM frequency can also be used without complication. One should consider that below 50Hz, the human eye can begin to see LED flicker, so it is recommended that users choose an adequate PWM frequency exceeding 50Hz.

### LED Selection

Although the AAT3143 is specifically intended for driving white LEDs, the device can also be used to drive most types of LEDs with forward voltage specifications ranging from 2.0V to 4.7V. LED applications may include main and sub-LCD display back-lighting, camera photo-flash applications, infrared (IR) diodes for remotes, and other loads benefiting from a controlled output current generated from a varying input voltage. Since the D1 to D4 input current sources are matched with negligible voltage dependence, the LED brightness will be matched regardless of the specific LED forward voltage ( $V_F$ ) levels. In some instances (e.g., in high luminous output applications such as photo flash), it may be necessary to drive high- $V_F$  type LEDs. The low dropout current sources in the AAT3143 make it capable of driving LEDs with forward voltages as high as 4.7V at full current from an input supply as low as 3.0V. Outputs can be paralleled to drive high-current LEDs without complication.

### Capacitor Selection

Careful selection of the four external capacitors  $C_{IN}$ ,  $C_1$ ,  $C_2$ , and  $C_{OUT}$  is important because they will affect turn-on time, output ripple, and transient performance. Optimum performance will be obtained when low equivalent series resistance (ESR) ceramic capacitors are used; in general, low ESR may be defined as less than 100m $\Omega$ . A value of 1 $\mu$ F for all four capacitors is a good starting point when choosing capacitors. If the LED current sources are only programmed for light current levels, then capacitor size may be decreased.

### Capacitor Characteristics

Ceramic composition capacitors are highly recommended over all other types of capacitors for use with the AAT3143. Ceramic capacitors offer many advantages over their tantalum and aluminum electrolytic counterparts. A ceramic capacitor typically has very low ESR, is lowest cost, has a smaller PCB footprint, and is non-polarized. Low-ESR ceramic capacitors help maximize charge pump transient response. Since ceramic capacitors are non-polarized, they are not prone to incorrect connection damage.

### Equivalent Series Resistance

ESR is an important characteristic to consider when selecting a capacitor. ESR is a resistance internal to a capacitor that is caused by the leads, internal connections, size or area, material composition, and ambient temperature. Capacitor ESR is typically measured in milliohms for ceramic capacitors and can range to more than several ohms for tantalum or aluminum electrolytic capacitors.

### Ceramic Capacitor Materials

Ceramic capacitors less than 0.1 $\mu$ F are typically made from NPO or C0G materials. NPO and C0G materials generally have tight tolerance and are very stable over temperature. Larger capacitor values are usually composed of X7R, X5R, Z5U, or Y5V dielectric materials. Large ceramic capacitors (i.e., greater than 2.2 $\mu$ F) are often available in low-cost Y5V and Z5U dielectrics, but capacitors greater than 1 $\mu$ F are not typically required for AAT3143 applications.



Capacitor area is another contributor to ESR. Capacitors that are physically large will have a lower ESR when compared to an equivalent material smaller capacitor. These larger devices can improve circuit transient response when compared to an equal value capacitor in a smaller package size.

### **Thermal Protection**

The AAT3143 has a built-in thermal protection circuit that will shut down the charge pump if the die temperature rises above the thermal limit, as is the case during a short-circuit of the CP pin.

### Ordering Information

Package	Marking <sup>1</sup>	Part Number (Tape and Reel) <sup>2</sup>
TSOPJW-12	ROXXY	AAT3143ITP-T1



All AnalogicTech products are offered in Pb-free packaging. The term “Pb-free” means semiconductor products that are in compliance with current RoHS standards, including the requirement that lead not exceed 0.1% by weight in homogeneous materials. For more information, please visit our website at <http://www.analogictech.com/pbfree>.

### Package Information

#### TSOPJW-12

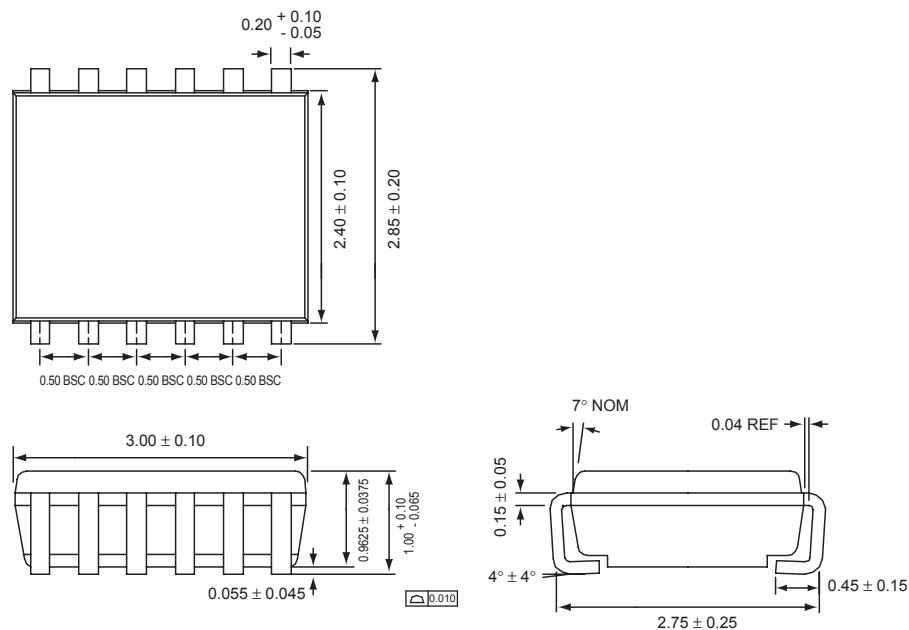

All dimensions in millimeters.

1. XYY = assembly and date code.
2. Sample stock is generally held on part numbers listed in **BOLD**.

© Advanced Analogic Technologies, Inc.

AnalogicTech cannot assume responsibility for use of any circuitry other than circuitry entirely embodied in an AnalogicTech product. No circuit patent licenses, copyrights, mask work rights, or other intellectual property rights are implied. AnalogicTech reserves the right to make changes to their products or specifications or to discontinue any product or service without notice. Customers are advised to obtain the latest version of relevant information to verify, before placing orders, that information being relied on is current and complete. All products are sold subject to the terms and conditions of sale supplied at the time of order acknowledgement, including those pertaining to warranty, patent infringement, and limitation of liability. AnalogicTech warrants performance of its semiconductor products to the specifications applicable at the time of sale in accordance with AnalogicTech's standard warranty. Testing and other quality control techniques are utilized to the extent AnalogicTech deems necessary to support this warranty. Specific testing of all parameters of each device is not necessarily performed.

AnalogicTech and the AnalogicTech logo are trademarks of Advanced Analogic Technologies Incorporated. All other brand and product names appearing in this document are registered trademarks or trademarks of their respective holders.

**Advanced Analogic Technologies, Inc.**  
 830 E. Arques Avenue, Sunnyvale, CA 94085  
 Phone (408) 737-4600  
 Fax (408) 737-4611