

SPECIFICATION FOR APPROVAL

- () Preliminary Specification
- () Final Specification

Title	42.0" WUXGA TFT LCD
-------	---------------------

BUYER	General
MODEL	

SUPPLIER	LG.Philips LCD Co., Ltd.
*MODEL	LC420WU1
SUFFIX	SL01

*When you obtain standard approval, please use the above model name without suffix

APPROVED BY	SIGNATURE DATE
/	
/	
/	

APPROVED BY	SIGNATURE DATE
C. H. Och / G. Manager	
REVIEWED BY	
H. M. Moon / Manager	
PREPARED BY	
Y.H.Choi / Engineer	

Please return 1 copy for your confirmation with your signature and comments.

**TV Product Development Dept.
LG. Philips LCD Co., Ltd**

Product Specification

CONTENTS

www.DataSheet4U.com

Number	ITEM	Page
	COVER	1
	CONTENTS	2
	RECORD OF REVISIONS	3
1	GENERAL DESCRIPTION	4
2	ABSOLUTE MAXIMUM RATINGS	5
3	ELECTRICAL SPECIFICATIONS	6
3-1	ELECTRICAL CHARACTERISTICS	6
3-2	INTERFACE CONNECTIONS	8
3-3	SIGNAL TIMING SPECIFICATIONS	12
3-4	SIGNAL TIMING WAVEFORMS	13
3-5	COLOR DATA REFERENCE	14
3-6	POWER SEQUENCE	15
4	OPTICAL SPECIFICATIONS	17
5	MECHANICAL CHARACTERISTICS	21
6	RELIABILITY	24
7	INTERNATIONAL STANDARDS	25
7-1	SAFETY	25
7-2	EMC	25
8	PACKING	26
8-1	DESIGNATION OF LOT MARK	26
8-2	PACKING FORM	26
9	PRECAUTIONS	27
9-1	MOUNTING PRECAUTIONS	27
9-2	OPERATING PRECAUTIONS	27
9-3	ELECTROSTATIC DISCHARGE CONTROL	28
9-4	PRECAUTIONS FOR STRONG LIGHT EXPOSURE	28
9-5	STORAGE	28
9-6	HANDLING PRECAUTIONS FOR PROTECTION FILM	28
Appendix A	Inverter Input Voltage Protection Circuit	29
Appendix B	Black Level and Black Uniformity	30

www.DataSheet4U.com

Product Specification

1. General Description

www.DataSheet4U.com

The LC420WU1 is a Color Active Matrix Liquid Crystal Display with an integral Cold Cathode Fluorescent Lamp(CCFL) backlight system. The matrix employs a-Si Thin Film Transistor as the active element. It is a transmissive display type which is operating in the normally black mode. It has a 42.02 inch diagonally measured active display area with WUXGA resolution (1080 vertical by 1920 horizontal pixel array). Each pixel is divided into Red, Green and Blue sub-pixels or dots which are arrayed in vertical stripes. Gray scale or the luminance of the sub-pixel color is determined with a 8-bit gray scale signal for each dot. Therefore, it can present a palette of more than 16.7M(true) colors.

It has been designed to apply the 8-bit 2-port LVDS interface.

It is intended to support LCD TV, PCTV where high brightness, super wide viewing angle, high color gamut, high color depth and fast response time are important.

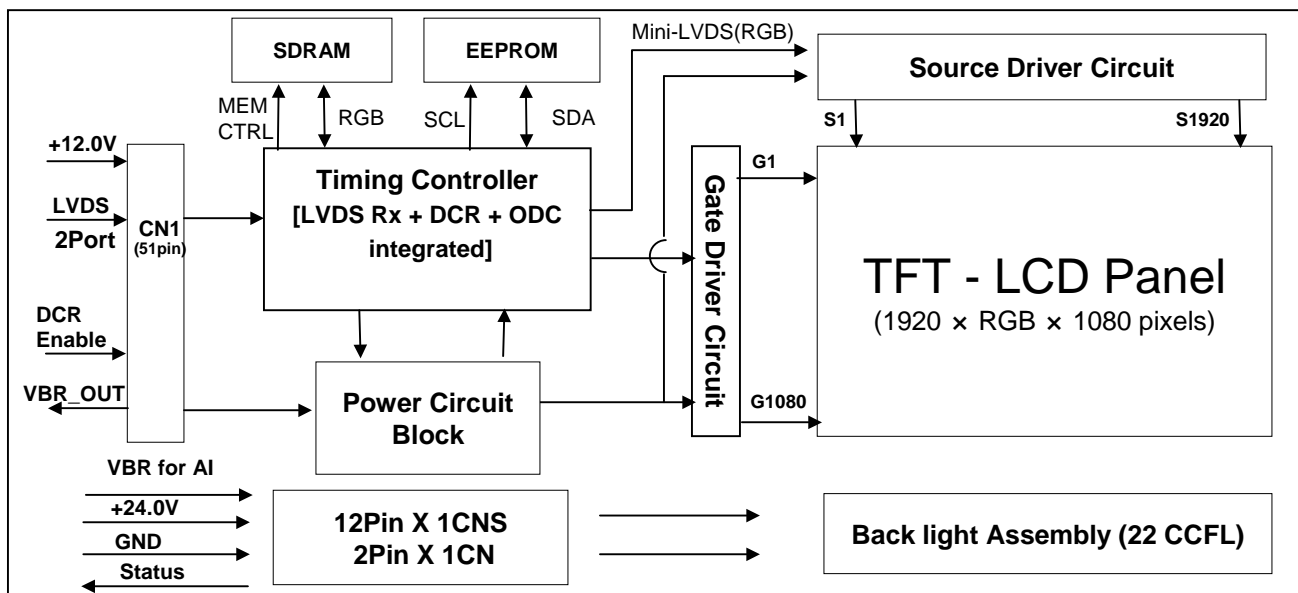

General Features

Active Screen Size	42.02 inches(1067.31mm) diagonal
Outline Dimension	1005.6(H) x 609.8 (V) x 55.5 mm(D) (Typ.)
Pixel Pitch	0.4845 mm x 0.4845 mm
Pixel Format	1920 horiz. by 1080 vert. Pixels, RGB stripe arrangement
Color Depth	8-bit, 16.7 M colors
Luminance, White	550 cd/m ² (Center 1point ,Typ.)
Viewing Angle (CR>10)	Viewing angle free (R/L 178 (Typ.), U/D 178 (Typ.))
Power Consumption	Total 187.3 W (Typ.) (Logic=7.3 W, Inverter=180 W [I _{BL} = 6.5mA])
Weight	14.5K g (Typ.)
Display Mode	Transmissive mode, Normally black
Surface Treatment	Hard coating(3H), Anti-glare treatment of the front polarizer

Product Specification

www.DataSheet4U.com

2. Absolute Maximum Ratings

The following items are maximum values which, if exceeded, may cause faulty operation or damage to the LCD module.

Table 1. ABSOLUTE MAXIMUM RATINGS

Parameter		Symbol	Value		Unit	Remark
			Min	Max		
Power Input Voltage	LCM	VLCD	-0.3	+14.0	Vdc	at 25 ± 2 °C
	Backlight inverter	VBL	+21.6	+26.0	Vdc	
ON/OFF Control Voltage		VON/OFF	-0.3	+5.25	Vdc	
Brightness Control Voltage		VBr	0	+3.3	Vdc	
Operating Temperature		TOP	0	+40	°C	Note 1
Storage Temperature		TST	-20	+50	°C	
Operating Ambient Humidity		HOP	10	90	%RH	
Storage Humidity		HST	10	90	%RH	

Note : 1. Temperature and relative humidity range are shown in the figure below.
Wet bulb temperature should be 39 °C Max. and no condensation of water.

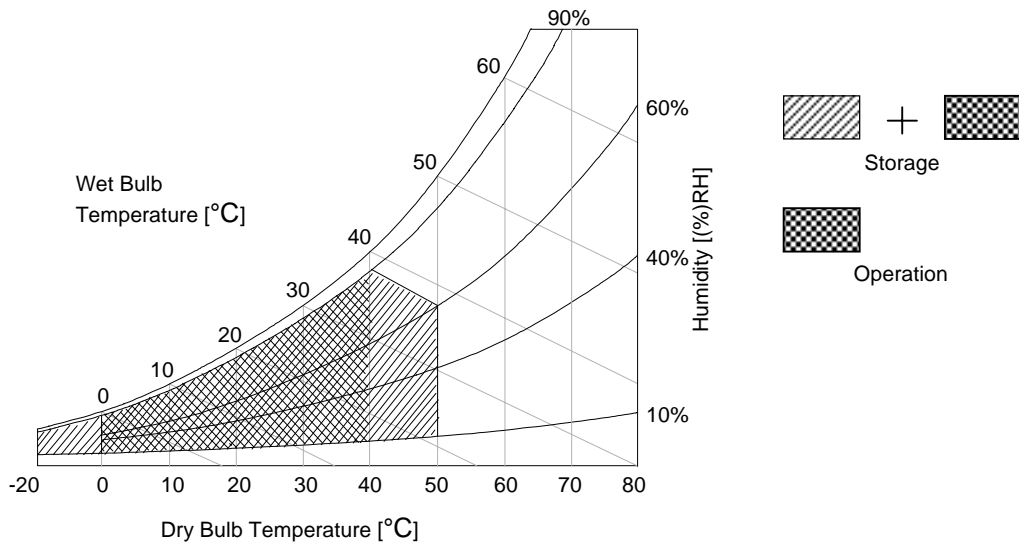

3. Electrical Specifications

3-1. Electrical Characteristics

It requires two power inputs. One is employed to power for the LCD circuit. The other is used for the CCFL backlight and inverter circuit.

Table 2. ELECTRICAL CHARACTERISTICS

Parameter	Symbol	Value			Unit	Note
		Min	Typ	Max		
Circuit :						
Power Input Voltage	V _{LCD}	11.4	12.0	12.6	V _{dc}	
Power Input Current	I _{LCD}	-	610	793	mA	1
		-	820	1066	mA	2
Power Consumption	P _{LCD}	-	7.3	9.5	Watt	1
Rush current	I _{RUSH}	-	-	3.0	A	3

- Note :
1. The specified current and power consumption are under the $V_{LCD}=12.0V$, $25 \pm 2^{\circ}C$, $f_V=60Hz$ condition whereas mosaic pattern(8 x 6) is displayed and f_V is the frame frequency.
 2. The current is specified at the maximum current pattern.
 3. The duration of rush current is about 2ms and rising time of power input is 1ms (min.).

White : 255Gray
Black : 0Gray

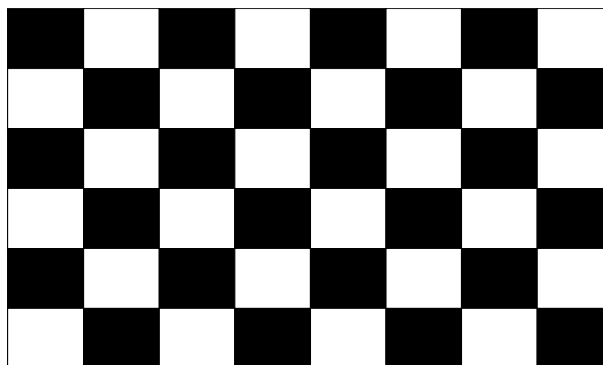

Mosaic Pattern(8 x 6)

Product Specification

www.DataSheet4U.com

Table 3. ELECTRICAL CHARACTERISTICS (Continue)

Parameter		Symbol	Value			Unit	Note
			Min	Typ	Max		
Inverter :							
Power Input Voltage		VBL	22.8	24.0	26.0	VDC	1
Power Supply Input Voltage Ripple			-0.2		0.2	Vp-p	
Unloading Input Voltage					28	Vdc	
Power Input Current		IBL	6	7.5	9	A	
Power Consumption		PBL	160	180	200	W	
Input Voltage for Control System Signals	Brightness Adjust	VBR	0		3.3	VDC	2
	On/Off	On	V on	2.5		5.0	VDC
		Off	V off	-0.3	0.0	0.5	VDC
Lamp :							
Life Time			50,000			Hrs	3

Note :

- Electrical characteristics are determined after the unit has been 'ON' and stable for approximately 120 minutes at $25 \pm 2^\circ\text{C}$
The specified current and power consumption are under the typical supply Input voltage, it is total power consumption.
The ripple voltage of the power supply input voltage is under 0.2 Vp-p.
LPL recommend Input Voltage is $24.0\text{V} \pm 5\%$.
- Brightness Control.
This VBR Voltage control brightness.

VBR Voltage	Function
3.3V	Maximum Brightness (100%)
0V	Minimum Brightness.(Burst On Duty 25%)

- The life is determined as the time at which luminance of the lamp is 50% compared to that of initial value at the typical lamp current on condition of continuous operating at $25 \pm 2^\circ\text{C}$.
Specified value is when lamp is aligned horizontally.
- The maximum value for unloading Input Voltage is only valid as inverter enable signal is off.
Please refer to page 16 for inverter on/off power sequence condition.

Product Specification

3-2. Interface Connections

www.DataSheet4U.com

This LCD module employs two kinds of interface connection, a 51-pin connector is used for the module electronics and two 12-pin connectors are used for the integral backlight system.

3-2-1. LCD Module

- LCD Connector(CN1): FI-R51S-HF(manufactured by JAE) or equivalent
- Mating Connector : FI-R51HL(JAE) or compatible

Table 4. MODULE CONNECTOR(CN1) PIN CONFIGURATION

No	Symbol	Description	No	Symbol	Description
1	Reserved (NC)	No connection	27	Reserved	No connection or GND
2	Reserved (NC)	No connection	28	RE0N	SECOND CHANNEL 0-
3	Reserved (NC)	No connection	29	RE0P	SECOND CHANNEL 0+
4	Reserved (NC)	No connection	30	RE1N	SECOND CHANNEL 1-
5	Reserved (NC)	No connection	31	RE1P	SECOND CHANNEL 1+
6	Reserved (NC)	No connection	32	RE2N	SECOND CHANNEL 2-
7	Reserved (NC)	No connection	33	RE2P	SECOND CHANNEL 2+
8	Reserved (NC)	No connection	34	GND	Ground
9	Reserved (NC)	No connection	35	RECLKN	SECOND CLOCK CHANNEL C-
10	Reserved (NC)	No connection	36	RECLKP	SECOND CLOCK CHANNEL C+
11	GND	Ground	37	GND	Ground
12	RO0N	FIRST CHANNEL 0-	38	RE3N	SECOND CHANNEL 3-
13	RO0P	FIRST CHANNEL 0+	39	RE3P	SECOND CHANNEL 3+
14	RO1N	FIRST CHANNEL 1-	40	Reserved (NC)	No connection
15	RO1P	FIRST CHANNEL 1+	41	Reserved (NC)	No connection
16	RO2N	FIRST CHANNEL 2-	42	Reserved	No connection or GND
17	RO2P	FIRST CHANNEL 2+	43	Reserved	No connection or GND
18	GND	Ground	44	GND	Ground
19	ROCLKN	FIRST CLOCK CHANNEL C-	45	GND	Ground
20	ROCLKP	FIRST CLOCK CHANNEL C+	46	GND	Ground
21	GND	Ground	47	NC	No connection
22	RO3N	FIRST CHANNEL 3-	48	VLCD	Power Supply +12.0V
23	RO3P	FIRST CHANNEL 3+	49	VLCD	Power Supply +12.0V
24	Reserved (NC)	No connection	50	VLCD	Power Supply +12.0V
25	Reserved (NC)	No connection	51	VLCD	Power Supply +12.0V
26	Reserved	No connection or GND	-	-	-

- Note :
1. All GND(ground) pins should be connected together to the LCD module's metal frame.
 2. All VLCD (power input) pins should be connected together.
 3. All Input levels of LVDS signals are based on the IEA 664 Standard.

Table 5. Required signal assignment for Flat Link (Thine : THC63LVD823) Transmitter(Pin7="L")

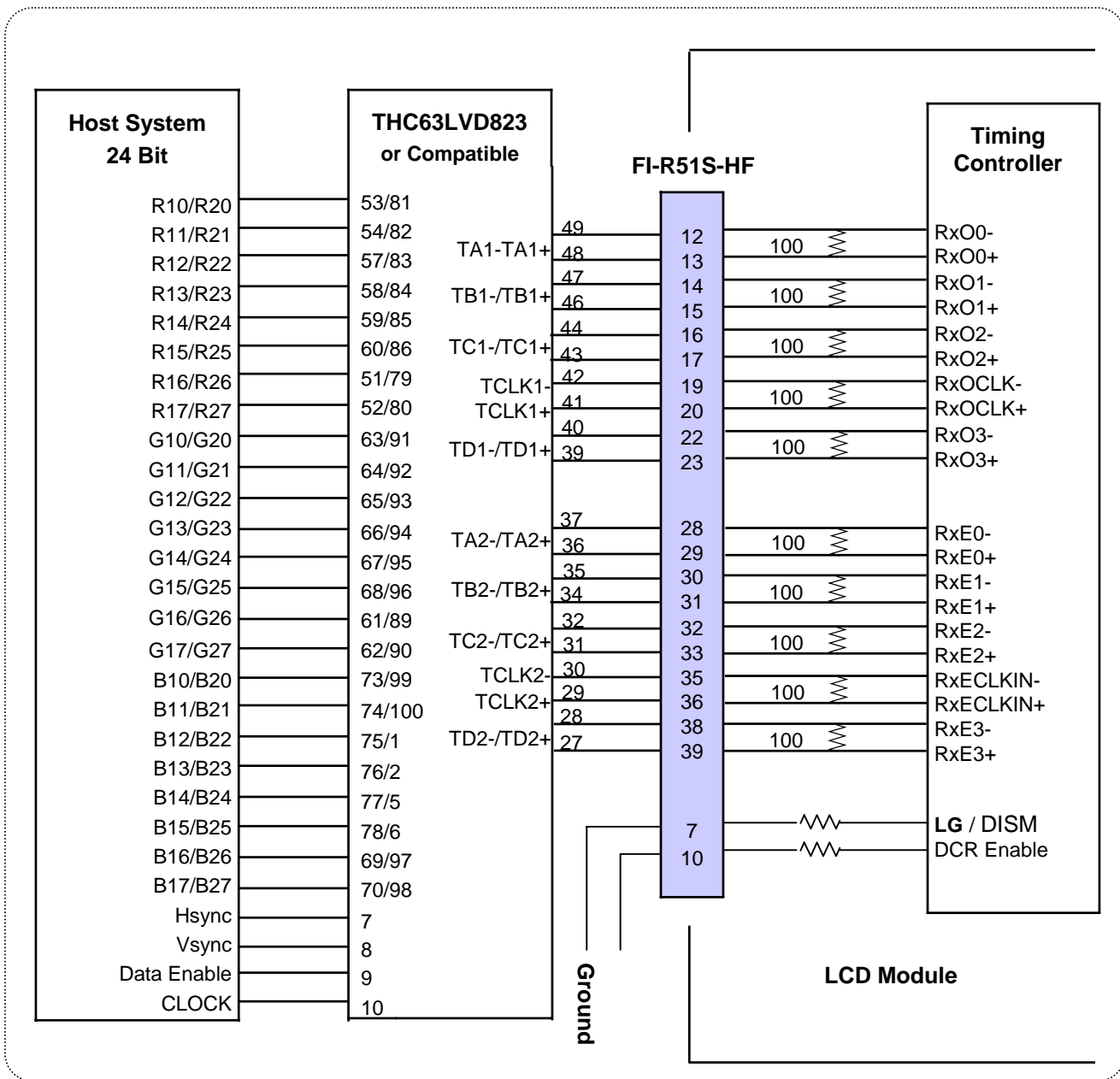

Note:

1. The LCD module uses a 100 Ohm() resistor between positive and negative lines of each receiver input.
2. Refer to LVDS transmitter data sheet for detail descriptions. (THC63LVD823 or Compatible)
3. '7' means MSB and '0' means LSB at R,G,B pixel data.

Table 6. Required signal assignment for Flat Link (Thine : THC63LVD823) Transmitter(Pin7="H")

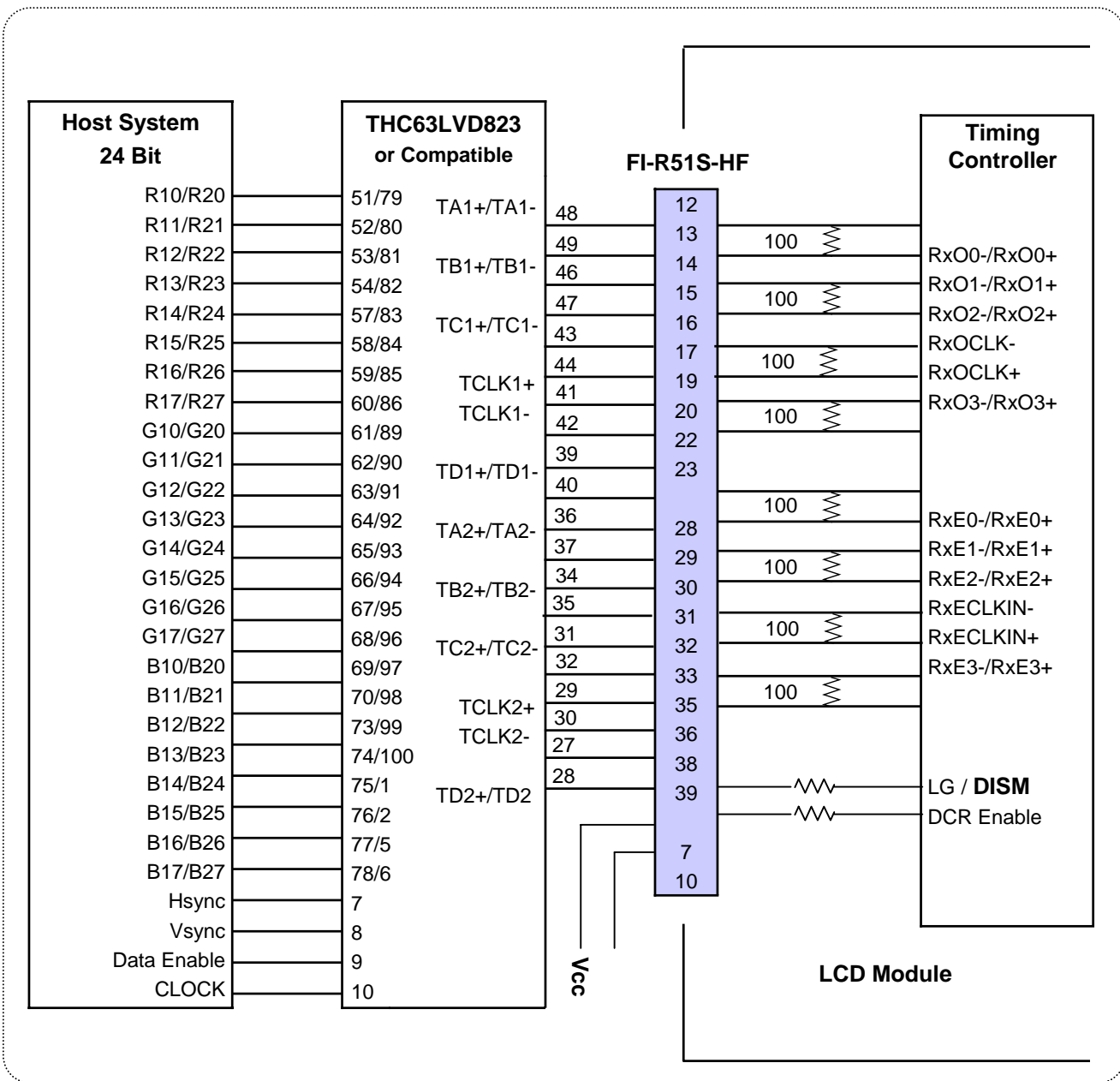

Note:

1. The LCD module uses a 100 Ohm() resistor between positive and negative lines of each receiver input.
2. Refer to LVDS transmitter data sheet for detail descriptions. (THC63LVD823 or Compatible)
3. '7' means MSB and '0' means LSB at R,G,B pixel data.

Product Specification

3-2-2. Backlight Inverter

www.DataSheet4U.com

Input Connector

-Inverter Connector : S12B-PH-SM3(manufactured by JST) or Equivalent

-Mating Connector : PHR-12 or Equivalent

Status Connector

-Inverter Connector : 20022WR-02A00(manufactured by Yeon Ho co., Korea)

-Mating Connector : 20022HR-02S00(manufactured by Yeon Ho co., Korea)

Table 7. INVERTER CONNECTOR PIN CONFIGURATION

Pin No	Symbol	Description	Master	Slave	Note
1	VBL	Power Supply +24.0V	VBL	VBL	
2	VBL	Power Supply +24.0V	VBL	VBL	
3	VBL	Power Supply +24.0V	VBL	VBL	
4	VBL	Power Supply +24.0V	VBL	VBL	
5	VBL	Power Supply +24.0V	VBL	VBL	
6	GND	POWER GND	GND	GND	
7	GND	POWER GND	GND	GND	
8	GND	POWER GND	GND	GND	1
9	GND	POWER GND	GND	GND	
10	GND	POWER GND	GND	GND	
11	VBR	0V ~ 3.3V	VBR	Don't care	2
12	On/Off	0V ~ 5.0V	On/Off	Don't care	3
Option Pin(Lamp Open Status Detection)					
1	GND	POWER GND	GND		
2	Status	Upper 3.0V(Normal), Under 0.7V(Abnormal)	Status		

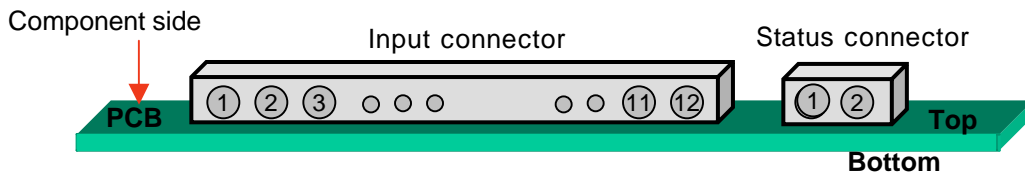

Note : 1. GND should be connected to the LCD module's metal frame.

2. Minimum Brightness : VBR = 0.0V
Maximum Brightness : VBR = 3.3V

3. VON : 2.5 ~ 5.0V
VOFF : -0.3 ~ 0.5V

Product Specification

3-3. Signal Timing Specifications
www.DataSheet4U.com

Table 8 and Table9 show the signal timing required at the input of the LVDS transmitter. All of the interface signal timing should be satisfied with the following specification for normal operation.

Table 8. TIMING TABLE for NTSC

ITEM	SYMBOL	Min.	Typ.	Max.	Unit	Notes	
DCLK Period	t_{CLK}	12.98	13.47	13.98	nsec		
DCLK Frequency	f_{CLK}	71.55	74.25	77	MHz	=148.5 /2	
Vertical	Frequency	f_V	57	60	63	Hz	
	Valid	t_{VV}	-	1080	-	Line	
	Blank	$t_{VT} - t_{VV}$	11	45	69	Line	
	Total	t_{VT}	1091	1125	1149	Line	
Horizontal	Frequency	f_H	65.46	67.5	68.94	KHz	
	Valid	t_{HV}	-	960	-	t_{CLK}	
	Blank	$t_{HT} - t_{HV}$	100	140	320	t_{CLK}	
	Total	t_{HT}	1060	1100	1280	t_{CLK}	=2200/2

Table 9. TIMING TABLE for PAL

ITEM	SYMBOL	Min.	Typ.	Max.	Unit	Notes	
DCLK Period	t_{CLK}	14.81	16.16	16.77	nsec		
DCLK Frequency	f_{CLK}	59.63	61.88	67.5	MHz	=123.75 /2	
Vertical	Frequency	f_V	47	50	53	Hz	
	Valid	t_{VV}	-	1080	-	Line	
	Blank	$t_{VT} - t_{VV}$	25	45	65	Line	
	Total	t_{VT}	1105	1125	1145	Line	
Horizontal	Frequency	f_H	55.25	56.25	57.25	KHz	
	Valid	t_{HV}	-	960	-	t_{CLK}	
	Blank	$t_{HT} - t_{HV}$	100	140	240	t_{CLK}	
	Total	t_{HT}	1060	1100	1200	t_{CLK}	=2200/2

Note :

1. The performance of the electro-optical characteristics may be influenced by variance of the vertical refresh rate.
2. Above Timing Tables are only valid for DE Mode.

3-4. Signal Timing Waveforms

www.DataSheet4U.com

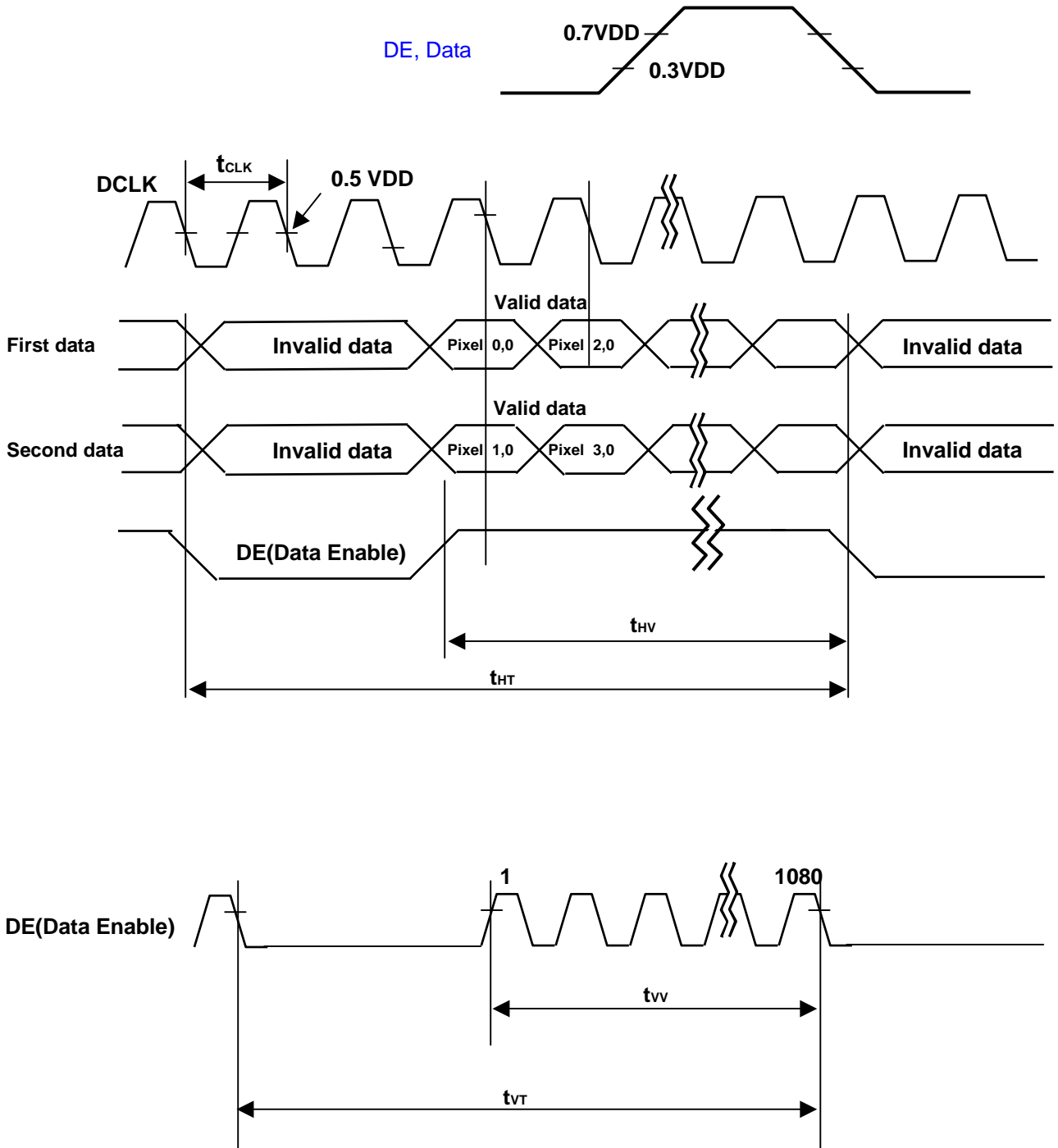

Product Specification

www.DataSheet4U.com

3-5. Color Data Reference

The brightness of each primary color(red,green,blue) is based on the 8-bit gray scale data input for the color. The higher binary input, the brighter the color. Table 10 provides a reference for color versus data input.

Table 10. COLOR DATA REFERENCE

Color		Input Color Data																							
		RED								GREEN								BLUE							
		MSB				LSB				MSB				LSB				MSB				LSB			
		R7	R6	R5	R4	R3	R2	R1	R0	G7	G6	G5	G4	G3	G2	G1	G0	B7	B6	B5	B4	B3	B2	B1	B0
Basic Color	Black	0	0	0	0	0	0	0	0	0	0	0	0	0	0	0	0	0	0	0	0	0	0	0	0
	Red (255)	1	1	1	1	1	1	1	1	0	0	0	0	0	0	0	0	0	0	0	0	0	0	0	0
	Green (255)	0	0	0	0	0	0	0	0	1	1	1	1	1	1	1	1	0	0	0	0	0	0	0	0
	Blue (255)	0	0	0	0	0	0	0	0	0	0	0	0	0	0	0	0	1	1	1	1	1	1	1	1
	Cyan	0	0	0	0	0	0	0	0	1	1	1	1	1	1	1	1	1	1	1	1	1	1	1	1
	Magenta	1	1	1	1	1	1	1	1	0	0	0	0	0	0	0	0	1	1	1	1	1	1	1	1
	Yellow	1	1	1	1	1	1	1	1	1	1	1	1	1	1	1	1	0	0	0	0	0	0	0	0
	White	1	1	1	1	1	1	1	1	1	1	1	1	1	1	1	1	1	1	1	1	1	1	1	1
RED	RED (000) Dark	0	0	0	0	0	0	0	0	0	0	0	0	0	0	0	0	0	0	0	0	0	0	0	0
	RED (001)	0	0	0	0	0	0	0	1	0	0	0	0	0	0	0	0	0	0	0	0	0	0	0	0
							
	RED (254)	1	1	1	1	1	1	1	0	0	0	0	0	0	0	0	0	0	0	0	0	0	0	0	0
	RED (255)	1	1	1	1	1	1	1	1	0	0	0	0	0	0	0	0	0	0	0	0	0	0	0	0
GREEN	GREEN (000) Dark	0	0	0	0	0	0	0	0	0	0	0	0	0	0	0	0	0	0	0	0	0	0	0	0
	GREEN (001)	0	0	0	0	0	0	0	0	0	0	0	0	0	0	0	1	0	0	0	0	0	0	0	0
							
	GREEN (254)	0	0	0	0	0	0	0	0	1	1	1	1	1	1	1	0	0	0	0	0	0	0	0	0
	GREEN (255)	0	0	0	0	0	0	0	0	1	1	1	1	1	1	1	1	0	0	0	0	0	0	0	0
BLUE	BLUE (000) Dark	0	0	0	0	0	0	0	0	0	0	0	0	0	0	0	0	0	0	0	0	0	0	0	0
	BLUE (001)	0	0	0	0	0	0	0	0	0	0	0	0	0	0	0	0	0	0	0	0	0	0	0	1
							
	BLUE (254)	0	0	0	0	0	0	0	0	0	0	0	0	0	0	0	0	1	1	1	1	1	1	1	0
	BLUE (255)	0	0	0	0	0	0	0	0	0	0	0	0	0	0	0	0	1	1	1	1	1	1	1	1

3-6. Power Sequence

3-6-1. LCD Driving circuit

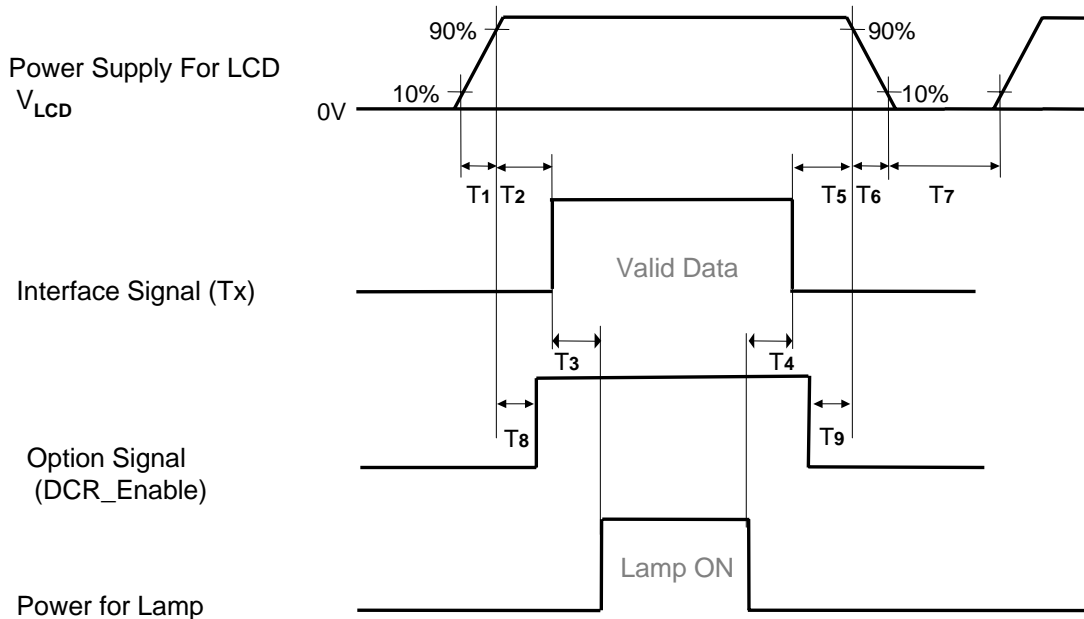

Table 11. POWER SEQUENCE

Parameter	Value			Unit
	Min	Typ	Max	
T1	0.5	-	20	ms
T2	0.5	-	50	ms
T3	200	-	-	ms
T4	200	-	-	ms
T5	0.5	-	50	ms
T6	-	-	100	ms
T7	2.0	-	-	s
T8	0 < T8 < T2			ms
T9	0 < T9 < T5			ms

- Note :
1. Please avoid floating state of interface signal at invalid period.
 2. When the interface signal is invalid, be sure to pull down the power supply V_{LCD} to 0V.
 3. The case when the T2/T5 exceed maximum specification, it operates protection pattern(Black pattern) till valid signal inputted. There is no reliability problem.
 4. The T3/T4 is recommended value, the case when failed to meet a minimum specification, abnormal display would be shown. There is no reliability problem.

Product Specification

www.DataSheet4U.com

3-6-2. On/Off for Inverter

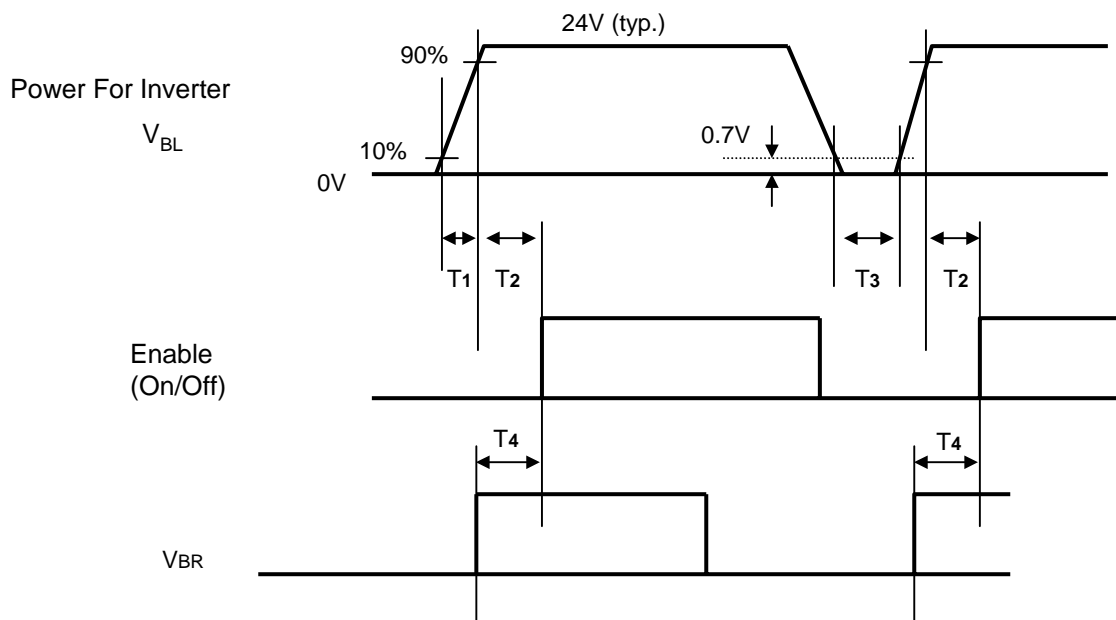

3-6-3. Deep condition for Inverter

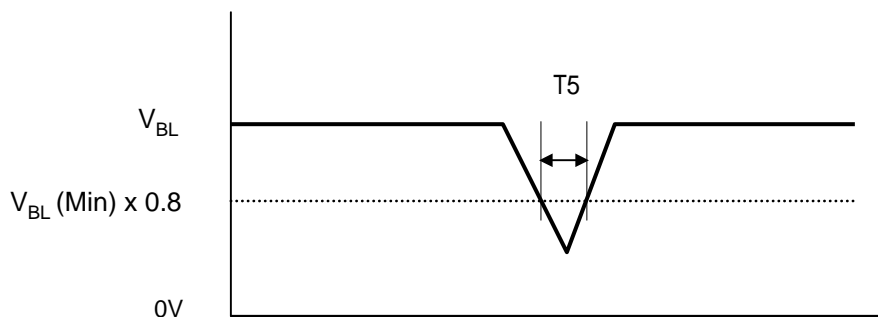

Table 12. POWER SEQUENCE FOR INVERTER

Parameter	Value			Unit	Remark
	Min	Typ	Max		
T1		-	20	ms	After Inverter's connected
T2	500	-	-	ms	
T3	200	-	-	ms	
T4	-100	-	-	ms	
T5	-	-	10	ms	$V_{BL}(\text{Min}) \times 0.8$

Product Specification

www.DataSheet4U.com

4. Optical Specification

Optical characteristics are determined after the unit has been 'ON' and stable for approximately 2 Hrs in a dark environment at $25 \pm 2^\circ\text{C}$. The specified optical values are measured at an approximate 50cm distance from the LCD surface on condition that viewing angle of Φ and θ equal to 0° .

FIG. 1 shows additional information concerning the measurement equipment and method.

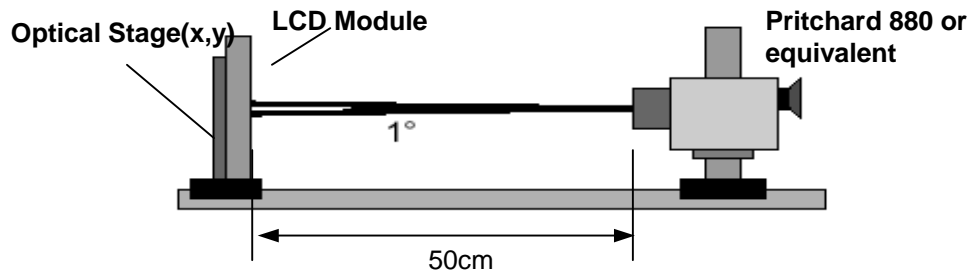

FIG. 1 Optical Characteristic Measurement Equipment and Method

Table 13. OPTICAL CHARACTERISTICS

$T_a = 25 \pm 2^\circ\text{C}$, $V_{LCD} = 12.0\text{V}$, $f_v = 60\text{Hz}$, $D_{clk} = 148.5\text{MHz}$, $VBR = 3.3\text{V}$

Parameter	Symbol	Value			Unit	Note	
		Min	Typ	Max			
Contrast Ratio	CR	600	800	-		1	
	CR with DCR	1100	1600	-			
Surface Luminance, white	L_{WH}	400	550	-	cd/m^2	2	
Luminance Variation	δ_{WHITE} 5P	-	-	1.6		3	
Response Time (Gray-to-Gray)	Gray-to-Gray	G to G	-	8	16	ms	4
	Rise + decay	$Tr_R + Tr_D$	-	18	-		
Color Coordinates [CIE1931]	RED	Rx	Typ -0.03	0.638	Typ +0.03		
		Ry		0.342			
	GREEN	Gx		0.286			
		Gy		0.613			
	BLUE	Bx		0.147			
		By		0.070			
	WHITE	Wx		0.285			
	Wy	0.293					
Viewing Angle (CR>10)							
	x axis, right($\phi=0^\circ$)	θ_r	85	89	-	degree	5
	x axis, left ($\phi=180^\circ$)	θ_l	85	89	-		
	y axis, up ($\phi=90^\circ$)	θ_u	85	89	-		
	y axis, down ($\phi=270^\circ$)	θ_d	85	89	-		
Gray Scale	Without DCR						6
	With DCR						
Black Level	L_{BLACK}	-	TBD	TBD		7	
Black Uniformity	δ_{BLACK} 5P	-	TBD	TBD			

www.DataSheet4U.com

Product Specification

Note :

www.DataSheet4U.com

1. Contrast Ratio(CR) is defined mathematically as :

$$\text{Contrast Ratio} = \frac{\text{Surface Luminance with all white pixels}}{\text{Surface Luminance with all black pixels}}$$

Measure Position : Center 1-point

2. Surface Luminance(L_{WH}) is the luminance value measured at an approximate 50cm distance from the center 1-point of LCD surface as all pixels displaying white. See FIG. 2 for more information.
3. The variation of surface luminance , δ WHITE is defined as :
 δ WHITE(5P) = Maximum($L_{on1}, L_{on2}, L_{on3}, L_{on4}, L_{on5}$) / Minimum($L_{on1}, L_{on2}, L_{on3}, L_{on4}, L_{on5}$)
 Where L_{on1} to L_{on5} are the luminance with all pixels displaying white at 5 locations .
 For more information, see the FIG. 2.
4. Response time is defined as the required time for the transition from G(N) to G(M) (Rise Time, Tr_R) and from G(M) to G(N) (Decay Time, Tr_D). For additional information see the FIG. 3. ($N < M$)
5. Viewing angle is the angle at which the contrast ratio is greater than 10. The angles are determined for the horizontal or x axis and the vertical or y axis with respect to the z axis which is normal to the LCD module surface. For more information, see the FIG. 4.
6. See Table 14 for gray scale specification
7. Black Level and Black Uniformity :
 This is only for the reference. Please refer to attached Appendix B for the details.

Table 14. GRAY SCALE SPECIFICATION

Gray Level	Luminance [%] (Typ.)	Luminance [%] (Typ.) with DCR
L0	0.19	0.06
L15	0.39	0.24
L31	1.16	0.82
L47	2.61	1.90
L63	4.80	3.64
L79	7.77	6.37
L95	11.56	9.77
L111	16.21	13.9
L127	21.73	18.5
L143	28.15	24.0
L159	35.50	31.1
L175	43.79	38.1
L191	53.04	46.7
L207	63.28	56.9
L223	74.50	69.5
L239	86.74	83.8
L255	100	100

Product Specification

Measuring point for surface luminance & measuring point for luminance variation.

www.DataSheet4U.com

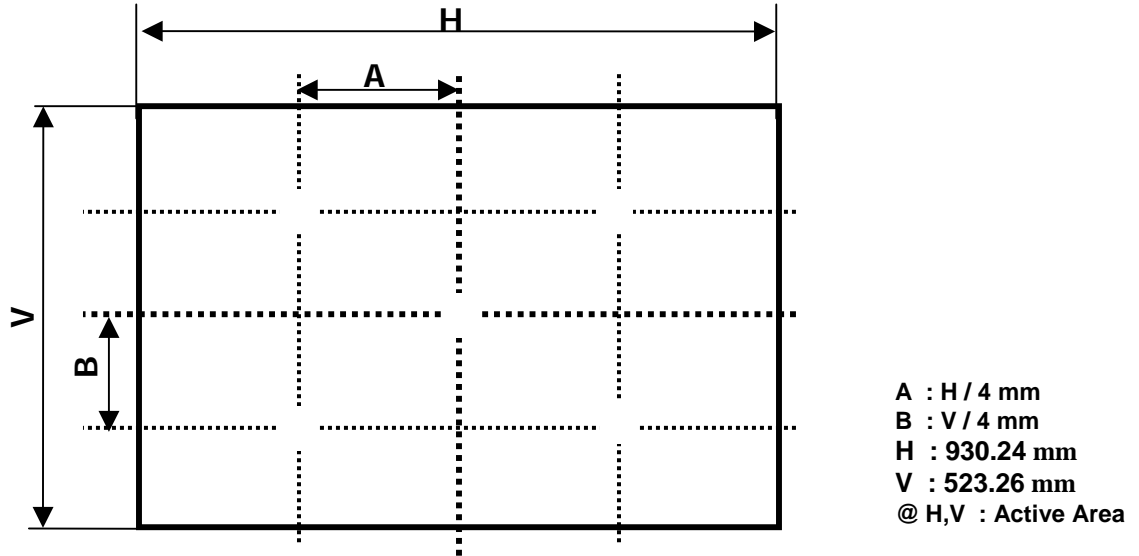

FIG. 2 5 Points for Luminance Measure

Response time is defined as the following figure and shall be measured by switching the input signal for "Gray(N)" and "Gray(M)".

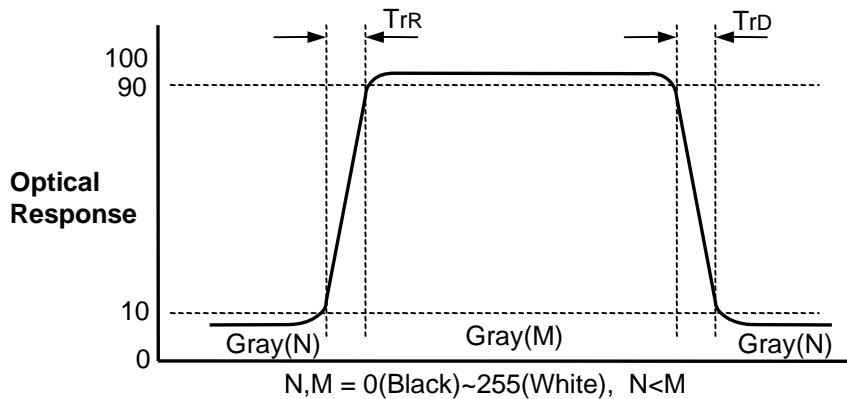

FIG. 3 Response Time

Product Specification

www.DataSheet4U.com

Dimension of viewing angle range

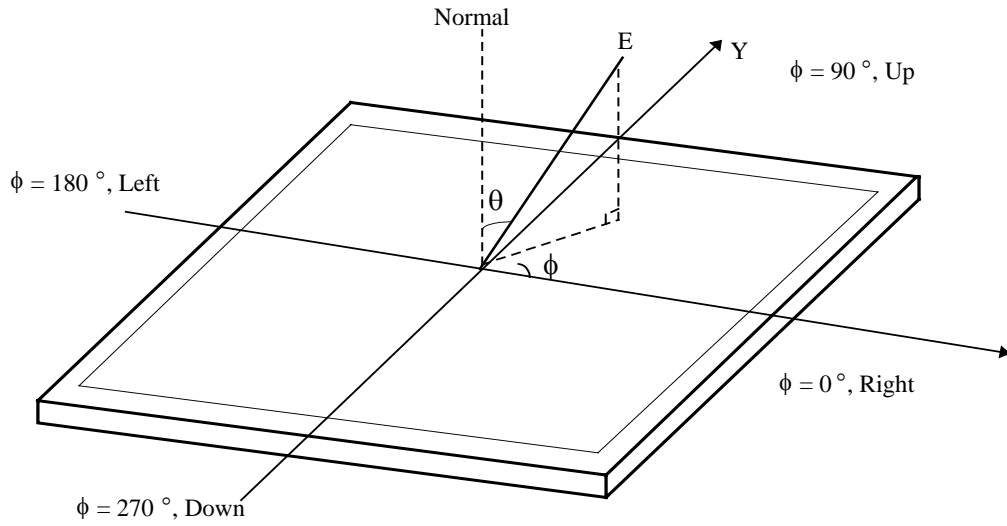

FIG. 4 Viewing Angle

5. Mechanical Characteristics

Table 13 provides general mechanical characteristics.

Table 15. MECHANICAL CHARACTERISTICS

Item	Value	
Outline Dimension	Horizontal	1005.6 mm
	Vertical	609.8 mm
	Depth	55.5 mm
Bezel Area	Horizontal	939.0 mm
	Vertical	531.0 mm
Active Display Area	Horizontal	930.24 mm
	Vertical	523.26 mm
Weight	14.5Kg (Typ.), 15.5Kg (Max.)	
Surface Treatment	Hard coating(3H) Anti-glare treatment of the front polarizer	

Note : Please refer to page21 and 22 for mechanic drawings in terms of tolerance.

Product Specification

www.DataSheet4U.com

<FRONT VIEW>

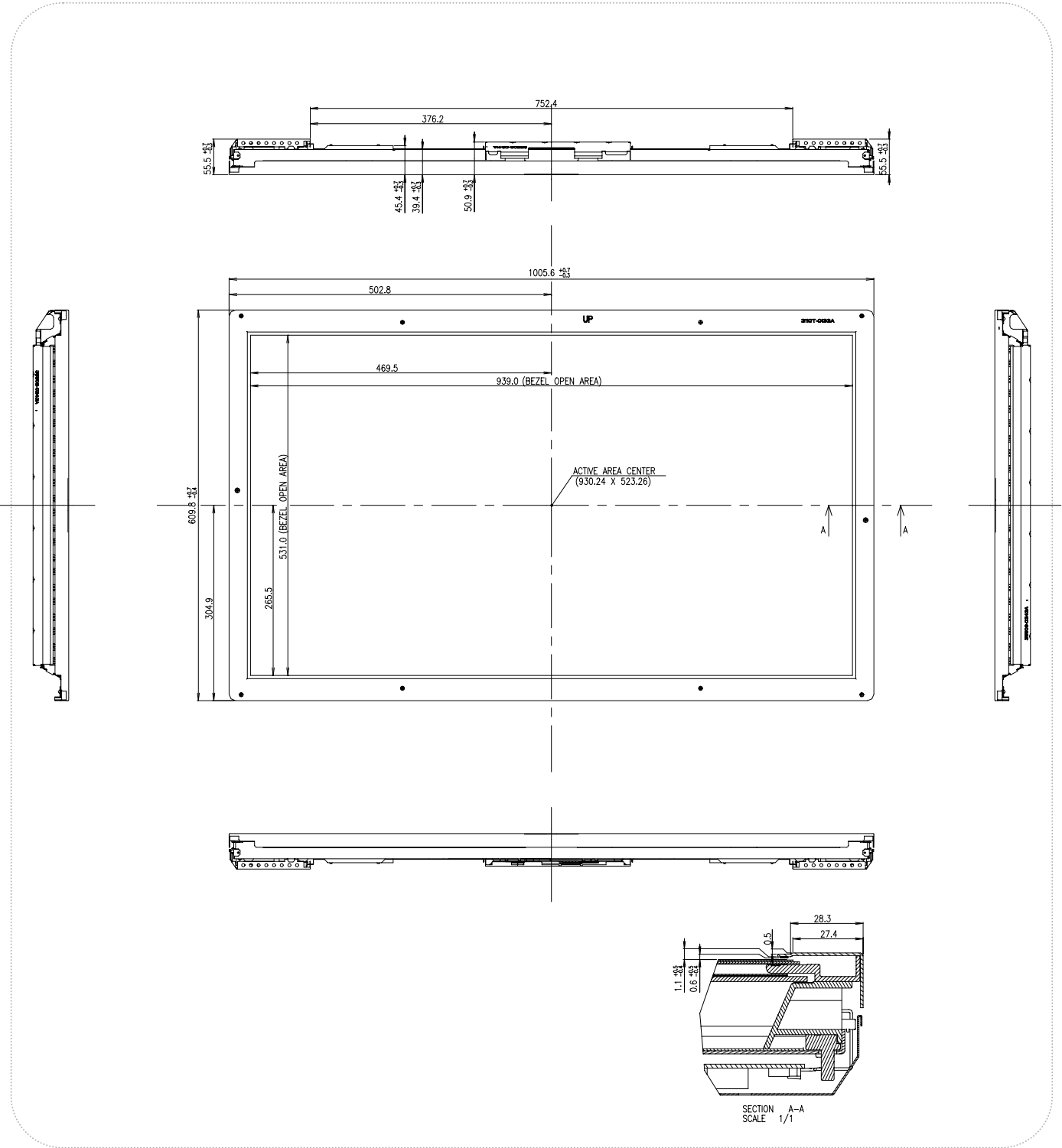

Product Specification

www.DataSheet4U.com

<REAR VIEW>

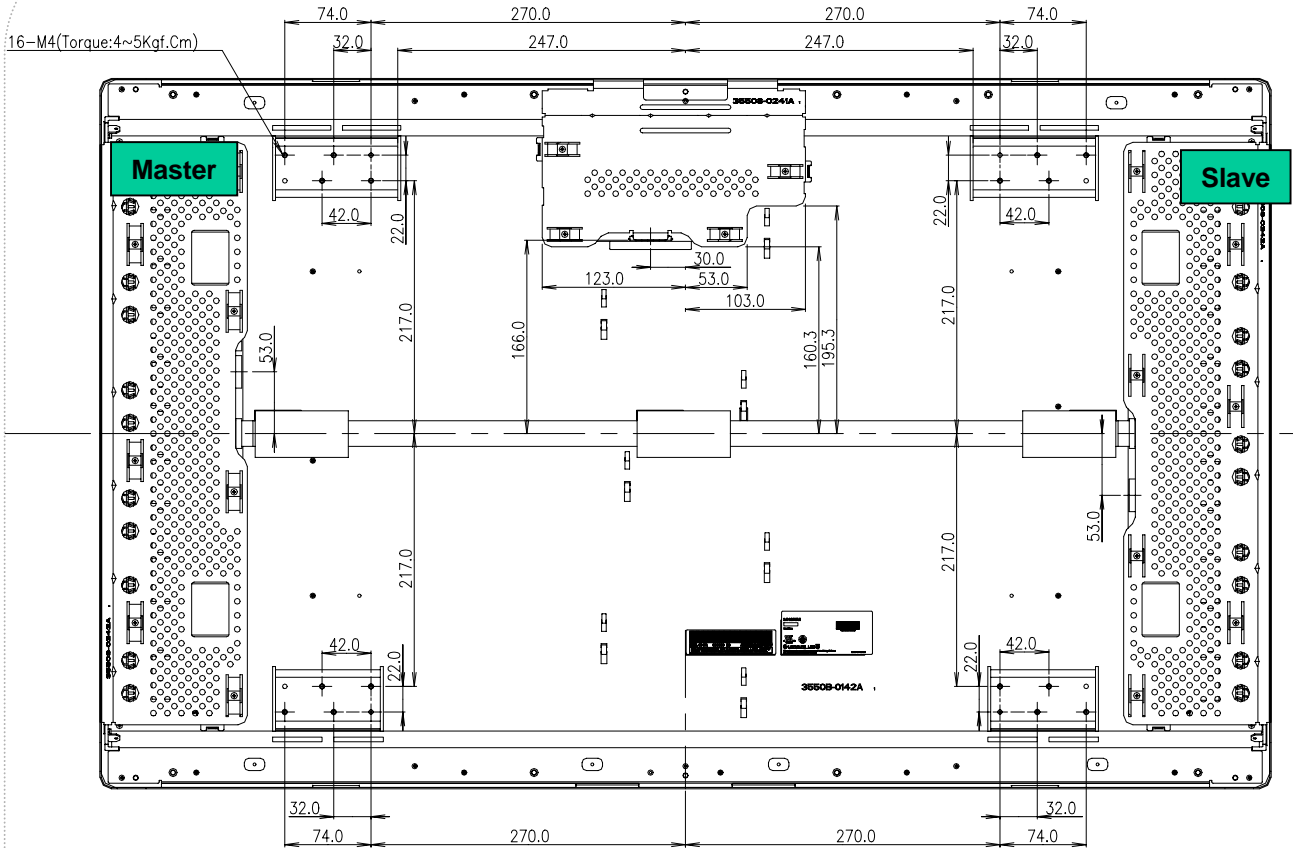

NOTES

- 1.Unspecified tolerances to be ± 0.5 .
- 2.This drawing is only preliminary data and can be changed without previous
- 3.Tilt and partial disposition tolerance of display area as follow.
 - 1)Y-Direction : $|A-B| \leq 1.5$
 - 2)X-Direction : $|C-D| \leq 1.5$

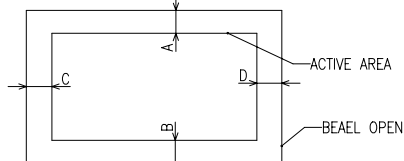

4.The same shape is same demension.

Product Specification

www.DataSheet4U.com

6. Reliability

Table 16. ENVIRONMENT TEST CONDITION

No.	Test Item	Condition
1	High temperature storage test	Ta= 50°C 240h
2	Low temperature storage test	Ta= -20°C 240h
3	High temperature operation test	Ta= 40°C 50%RH 240h
4	Low temperature operation test	Ta= 0°C 240h
5	Vibration test (non-operating)	Waveform : Random Vibration Level : 1.0G RMS Bandwidth : 10-500Hz Duration : X,Y,Z, 10 min / One time each direction
6	Shock test (non-operating)	Shock level : 100G Waveform : half sine wave, 2ms Direction : ± X, ± Y, ± Z One time each direction
7	Humidity condition Operation	Ta= 40 °C, 90%RH
8	Altitude operating storage / shipment	0 - 14,000 feet(4267.2m) 0 - 40,000 feet(12192m)

7. International Standards

7-1. Safety

- a) UL 60950-1:2003, First Edition, Underwriters Laboratories, Inc., Standard for Safety of Information Technology Equipment.
- b) CAN/CSA C22.2, No. 60950-1-03 1st Ed. April 1, 2003, Canadian Standards Association, Standard for Safety of Information Technology Equipment.
- c) EN 60950-1:2001, First Edition, European Committee for Electrotechnical Standardization(CENELEC) European Standard for Safety of Information Technology Equipment.

7-2. EMC

- a) ANSI C63.4 "Methods of Measurement of Radio-Noise Emissions from Low-Voltage Electrical and Electrical Equipment in the Range of 9kHz to 40GHz. "American National Standards Institute(ANSI), 1992
- b) C.I.S.P.R. "Limits and Methods of Measurement of Radio Interface Characteristics of Information Technology Equipment." International Special Committee on Radio Interference.
- c) EN 55022 "Limits and Methods of Measurement of Radio Interface Characteristics of Information Technology Equipment." European Committee for Electrotechnical Standardization.(CENELEC), 1998 (Including A1: 2000)

Product Specification

8. Packing

8-1. Designation of Lot Mark

a) Lot Mark

A	B	C	D	E	F	G	H	I	J	K	L	M
---	---	---	---	---	---	---	---	---	---	---	---	---

A,B,C : SIZE(INCH)

D : YEAR

F : PANEL CODE

H : ASSEMBLY CODE

E : MONTH

G : FACTORY CODE

I,J,K,L,M : SERIAL NO.

Note

1. YEAR

Year	97	98	99	2000	2001	2002	2003	2004	2005	2006	2007
Mark	7	8	9	0	1	2	3	4	5	6	7

2. MONTH

Month	Jan	Feb	Mar	Apr	May	Jun	Jul	Aug	Sep	Oct	Nov	Dec
Mark	1	2	4	4	5	6	7	8	9	A	B	C

3. PANEL CODE

Panel Code	P1 Factory	P2 Factory	P3 Factory	P4 Factory	P5 Factory	Hydis Panel
Mark	1	2	3	4	5	H

4. FACTORY CODE

Factory Code	LPL Gumi	LPL Nanjing	Hee Sung
Mark	K	C	D

5. SERIAL NO.

Year	1 ~ 99999	100000 ~
Mark	00001 ~ 99999	A0001 ~ A9999, , Z9999

b) Location of Lot Mark

Serial NO. is printed on the label. The label is attached to the backside of the LCD module.
This is subject to change without prior notice.

8-2. Packing Form

a) Package quantity in one Pallet : 10 pcs

b) Pallet Size : 1140 mm X 1000 mm X 810 mm.

9. Precautions

Please pay attention to the followings when you use this TFT LCD module.

9-1. Mounting Precautions

- (1) You must mount a module using holes arranged in four corners or four sides.
- (2) You should consider the mounting structure so that uneven force (ex. Twisted stress) is not applied to the module. And the case on which a module is mounted should have sufficient strength so that external force is not transmitted directly to the module.
- (3) Please attach the surface transparent protective plate to the surface in order to protect the polarizer. Transparent protective plate should have sufficient strength in order to resist external force.
- (4) You should adopt radiation structure to satisfy the temperature specification.
- (5) Acetic acid type and chlorine type materials for the cover case are not desirable because the former generates corrosive gas of attacking the polarizer at high temperature and the latter causes circuit break by electro-chemical reaction.
- (6) Do not touch, push or rub the exposed polarizers with glass, tweezers or anything harder than HB pencil lead. And please do not rub with dust clothes with chemical treatment. Do not touch the surface of polarizer for bare hand or greasy cloth.(Some cosmetics are detrimental to the polarizer.)
- (7) When the surface becomes dusty, please wipe gently with absorbent cotton or other soft materials like chamois soaks with petroleum benzene. Normal-hexane is recommended for cleaning the adhesives used to attach front / rear polarizers. Do not use acetone, toluene and alcohol because they cause chemical damage to the polarizer.
- (8) Wipe off saliva or water drops as soon as possible. Their long time contact with polarizer causes deformations and color fading.
- (9) Do not open the case because inside circuits do not have sufficient strength.

9-2. Operating Precautions

- (1) The spike noise causes the mis-operation of circuits. It should be lower than following voltage :
 $V = \pm 200\text{mV}$ (Over and under shoot voltage)
- (2) Response time depends on the temperature.(In lower temperature, it becomes longer.)
- (3) Brightness depends on the temperature. (In lower temperature, it becomes lower.)
And in lower temperature, response time(required time that brightness is stable after turned on) becomes longer.
- (4) Be careful for condensation at sudden temperature change. Condensation makes damage to polarizer or electrical contacted parts. And after fading condensation, smear or spot will occur.
- (5) When fixed patterns are displayed for a long time, remnant image is likely to occur.
- (6) Module has high frequency circuits. Sufficient suppression to the electromagnetic interference shall be done by system manufacturers. Grounding and shielding methods may be important to minimized the interference.
- (7) Please do not give any mechanical and/or acoustical impact to LCM. Otherwise, LCM can't be operated its full characteristics perfectly.
- (8) A screw which is fastened up the steels should be a machine screw.
(if not, it causes metallic foreign material and deal LCM a fatal blow)
- (9) Please do not set LCD on its edge.

9-3. Electrostatic Discharge Control

Since a module is composed of electronic circuits, it is not strong to electrostatic discharge. Make certain that treatment persons are connected to ground through wrist band etc. And don't touch interface pin directly.

9-4. Precautions for Strong Light Exposure

Strong light exposure causes degradation of polarizer and color filter.

9-5. Storage

When storing modules as spares for a long time, the following precautions are necessary.

- (1) Store them in a dark place. Do not expose the module to sunlight or fluorescent light. Keep the temperature between 5°C and 35°C at normal humidity.
- (2) The polarizer surface should not come in contact with any other object.
It is recommended that they be stored in the container in which they were shipped.

9-6. Handling Precautions for Protection Film

- (1) The protection film is attached to the bezel with a small masking tape.
When the protection film is peeled off, static electricity is generated between the film and polarizer.
This should be peeled off slowly and carefully by people who are electrically grounded and with well ion-blown equipment or in such a condition, etc.
- (2) When the module with protection film attached is stored for a long time, sometimes there remains a very small amount of glue still on the bezel after the protection film is peeled off.
- (3) You can remove the glue easily. When the glue remains on the bezel surface or its vestige is recognized, please wipe them off with absorbent cotton waste or other soft material like chamois soaked with normal-hexane.

Appendix A : Inverter Input Voltage Protection Circuit

The CAS is only defined as spec-in parameters, so LPL and Philips agree to make an appendix for inverter input voltage circuit application in terms of LC420WU1-SL01

www.DataSheet4U.com

1. Input Voltage Protection Circuit definition

Input Voltage Protection Circuit perceive abnormal input voltage coming at the Master & Slave inverter.

In case the inverter input voltage level is under 19.V or over 27.5V, this circuit operates for preventing inverter's abnormal operation.

If inverter input voltage come back normal condition, this protection circuit will be reset and inverter works properly.

2. Input Voltage Protection Circuit Contents

The original purpose of inverter input voltage protection circuit is only for preventing inverter's damage. Please don't regard this circuit and voltage level as the parameters which should be controlled.

1) High Voltage Protection : Over 27.5V

2) Low Voltage Protection : Under 19V

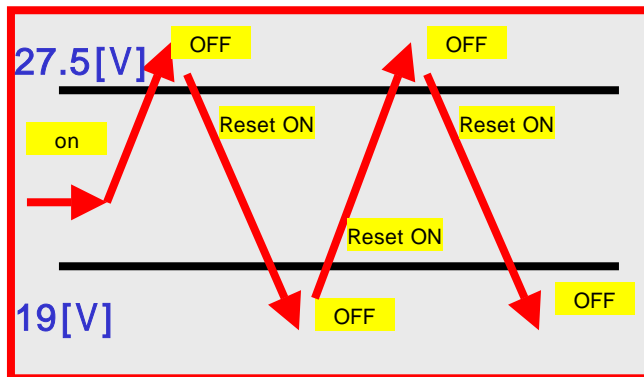

3. Agreement

The protection circuit can't be eliminated without both of LPL and Philips agreement

Appendix B : Black Level and Black Uniformity

It is not available to be specified black level and black uniformity on the spec at this moment. So LPL will get more actual data for the future production(LC420WU1-SL01).

1. Black Level :

Surface Luminance of Black (L_{BLACK}) is the luminance value at center 1-point.

2. Black Uniformity

The variation of surface luminance of black , δ_{BLACK} is defined as :

$$\delta_{BLACK} = \text{Maximum}(L_{on1}, L_{on2}, L_{on3}, L_{on4}, L_{on5}) / \text{Minimum}(L_{on1}, L_{on2}, L_{on3}, L_{on4}, L_{on5})$$

3. Sampling Size : **regular RV event test quantity (5 pcs)**

4. Measurement Method : Follow same rule as optical characteristics measurement.

5. Measurement location: refer to below.

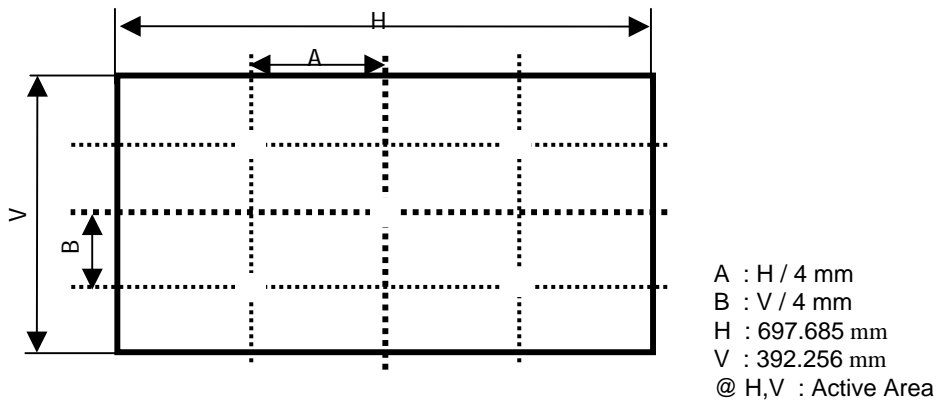

6. Current Status

Below is actual data of production on **RV (4 Jul 2005 ~ 5 Jul 2005)**. This is only useful for reference.

1) light leakage & Stitch limit sample : # 177

2) Touch limit sample : #148

No.	Luminance	Black Level
1	639	0.75
2	606	0.76
3	623	0.78
4	619	0.75
5	647	0.78

7. Plan to review Black Level and Black Uniformity

LPL will continue to monitor the black level and uniformity. Both LPL and Philips will review black level as well as black uniformity together. This spec will be discussed sooner or later. (end of Sept.)