

# FD1000A

## 3-COM 52-SEG, 4-COM 51-SEG LCD Display Driver

January. 2008

Ver. 1.0

### CONTENTS

1. General Description & Features	-----	page 2
2. Pin Assignment & Block Diagram	-----	page 3
3. Pin Descriptions	-----	page 4
4. Serial Data Format and Timing	-----	page 4
5. Control Data Functions	-----	page 5
6. Display Data to Segment Output Pin Correspondence	-----	page 7
7. LCD Driving Waveform	-----	page 9
8. Application Circuit	-----	page 11
9. INH\ Pin and Display Control	-----	page 17
10. Absolute Maximum Ratings	-----	page 18
11. D.C Electrical Characteristics	-----	page 18
12. A.C Electrical Characteristics	-----	page 19
13. Package Dimensions	-----	page 20

## **3 COM, 4 COM LCD Display Driver**

### **General Description**

The FD1000A is a 1/3 or 1/4 duty LCD driver for segment type LCD panel. It can be used for frequency display in microprocessor-controlled receiver and in other display application.

The FD1000A chooses numbers of common and general-purpose output ports by instructions. Therefore, It drives 156-segment at 1/3 duty in use of 3 commons or 204-segment at 1/4 duty in use of 4 commons. Also it provides 12 general-purpose output ports.

### **Features**

- Programmable Duty Ratio
  - 1/3 Duty : Up to 156 Segment Outputs
  - 1/4 Duty : Up to 204 Segment Outputs
- Programmable LCD Bias Ratio : 1/2 Bias or 1/3 Bias
- Programmable General-purpose Output Port Function (Only 1/4 Duty Mode)
- Internal LCD Driving Voltage Generator Circuit
- Normal & Diminish LCD Dividing resistors Selection (Only 1/4 Duty Mode)
- Power Saving Mode and all Segment OFF Function
- RC Oscillation Circuit
- Serial Interface ( SI, SCK, CE and INH/ ) for 3V or 5V
- Power supply Voltage : 2.7V ~ 5.5V
- Package Type
  - 64-LQFP-1414, 64-LQFP-1010

## Pin Assignment

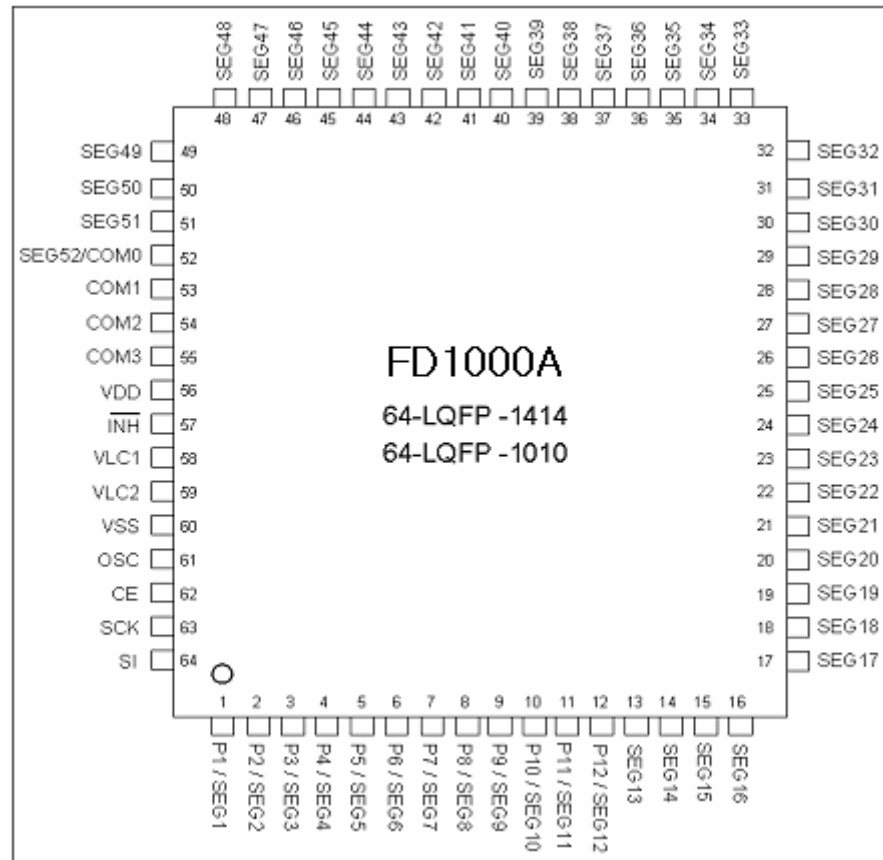

## Block Diagram

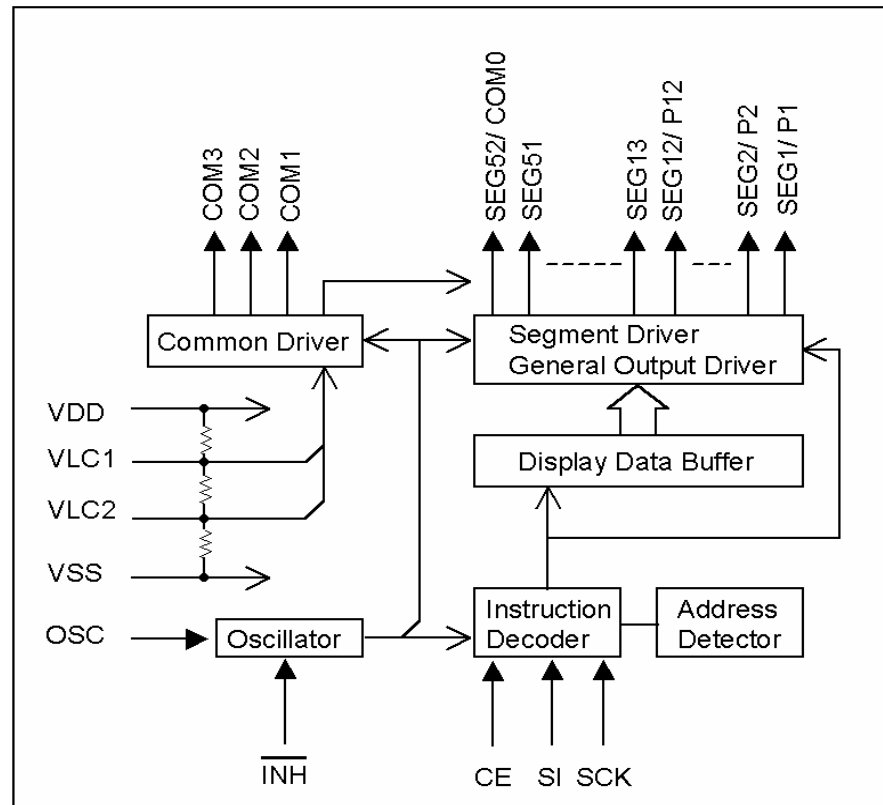

Pin Descriptions

Pin No.	Pin Name	I/O	Pin Description
1 ~ 12	SEG1/ P1 ~ SEG12/ P12	O	LCD Segment output pins / General-purpose output pins(Only 1/4Duty Mode) Select Segment output pins or General-purpose output pins by the instruction.
13 ~ 51	SEG13~SEG51	O	LCD Segment output pins.
52	SEG52/ COM0	O	LCD Segment output pin or LCD Common output pin. SEG52 in 1/3 Duty use, COM0 in 1/4 Duty use.
53 ~ 55	COM1 ~ COM3	O	LCD Common output pins.
57	INH\	I	Display off control input pin INH\ = VSS, Display forced off INH\ = VDD, Display on
58, 59	VLC1, VLC2	I/O	LCD power supply
61	OSC	I/O	Oscillator output pin.
62	CE	I	Chip enable input pin
63	SCK	I	Shift clock input pin
64	SI	I	Serial Data input pin
56	VDD	-	Power supply
60	VSS	-	Ground

Serial Data Format and Timing

- 1/3 Duty , SCK is stopped at low level

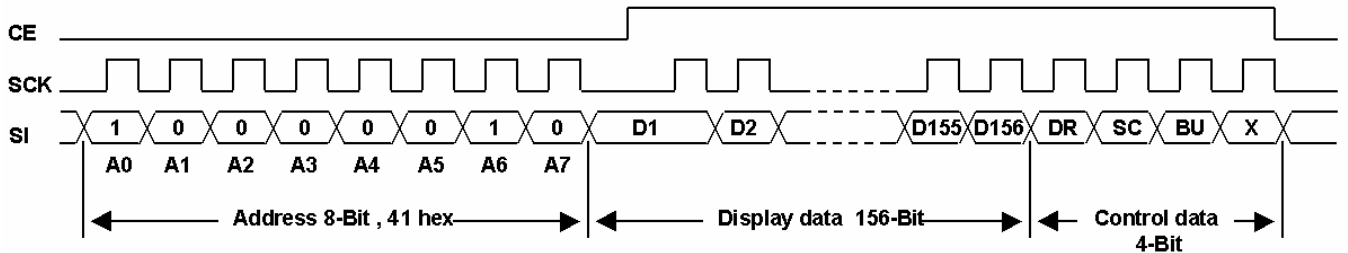

- 1/3 Duty , SCK is stopped at high level

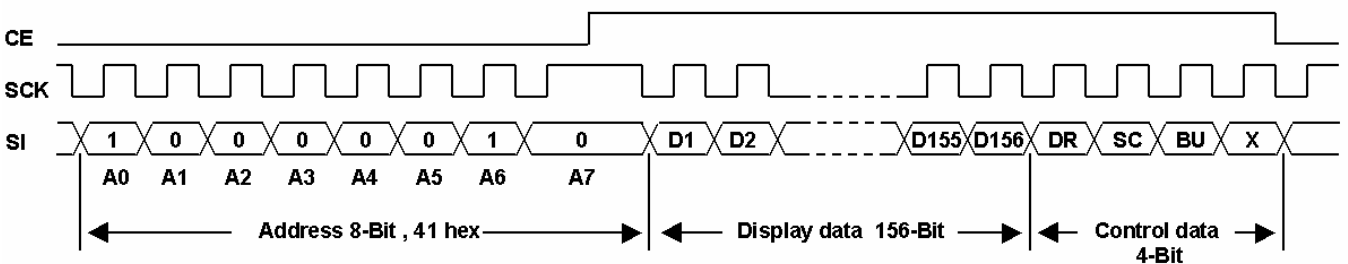

Note : X = don't care

- 1/4 Duty , SCK is stopped at low level

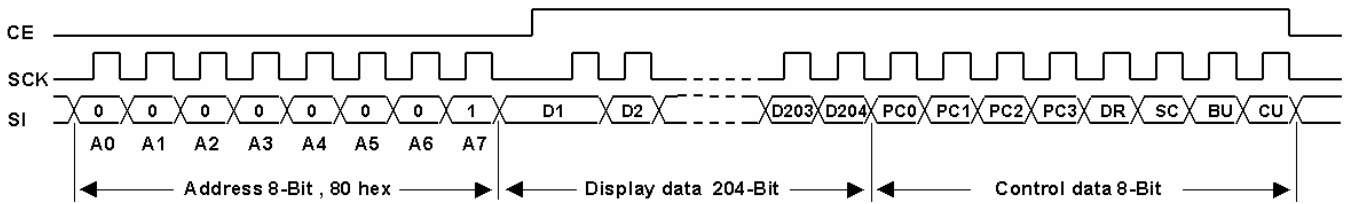

- 1/4 Duty , SCK is stopped at high level

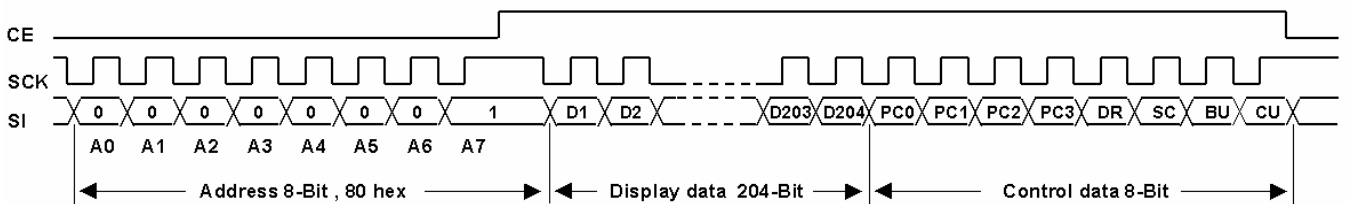

### Control Data Functions

- Display Data : D1 to D156 (1/3 Duty), D1 to D204 (1/4 Duty)  
When the bit of a display data is “1”, the LCD display is turn ON  
When the bit value is “0”, the display is turn OFF.
- Duty Selection : Duty select address is which sets LCD driving duty ratio 1/3 or 1/4 duty.  
Address = 41 Hex, 1/3 Duty ( 3-Common 52-Segment LCD Driver )  
Address = 80 Hex, 1/4 Duty ( 4-Common 51-Segment LCD Driver )
- DR : 1/2 or 1/3 Bias Selection Bit  
DR data = “0” , 1/2 Bias Drive  
= “1” , 1/3 Bias Drive
- SC : Segment ON/OFF Control Bit  
SC data = “0” , Display ON  
= “1” , Display OFF
- BU : Power saving Control Bit  
BU data = “0” , Normal Mode  
= “1” , Power-saving Mode.  
In this mode the Oscillator is stopped and the segment pins output Vss levels.
- CU : LCD dividing resistors selection bit (Only 1/4 Duty Mode)  
CU data = “0” , Normal Mode (RLCD=R)  
= “1” , Low current Mode (RLCD=2\*R)

- PC0 to PC1 : Segment /General-purpose output pin selection bits (Only 1/4 Duty Mode)

Control data				Segment output / General output port selection											
PC0	PC1	PC2	PC3	SEG1/P1	SEG2/P2	SEG3/P3	SEG4/P4	SEG5/P5	SEG6/P6	SEG7/P7	SEG8/P8	SEG9/P9	SEG10/P10	SEG11/P11	SEG12/ P12
0	0	0	0	SEG1	SEG2	SEG3	SEG4	SEG5	SEG6	SEG7	SEG8	SEG9	SEG10	SEG11	SEG12
0	0	0	1	P1	SEG2	SEG3	SEG4	SEG5	SEG6	SEG7	SEG8	SEG9	SEG10	SEG11	SEG12
0	0	1	0	P1	P2	SEG3	SEG4	SEG5	SEG6	SEG7	SEG8	SEG9	SEG10	SEG11	SEG12
0	0	1	1	P1	P2	P3	SEG4	SEG5	SEG6	SEG7	SEG8	SEG9	SEG10	SEG11	SEG12
0	1	0	0	P1	P2	P3	P4	SEG5	SEG6	SEG7	SEG8	SEG9	SEG10	SEG11	SEG12
0	1	0	1	P1	P2	P3	P4	P5	SEG6	SEG7	SEG8	SEG9	SEG10	SEG11	SEG12
0	1	1	0	P1	P2	P3	P4	P5	P6	SEG7	SEG8	SEG9	SEG10	SEG11	SEG12
0	1	1	1	P1	P2	P3	P4	P5	P6	P7	SEG8	SEG9	SEG10	SEG11	SEG12
1	0	0	0	P1	P2	P3	P4	P5	P6	P7	P8	SEG9	SEG10	SEG11	SEG12
1	0	0	1	P1	P2	P3	P4	P5	P6	P7	P8	P9	SEG10	SEG11	SEG12
1	0	1	0	P1	P2	P3	P4	P5	P6	P7	P8	P9	P10	SEG11	SEG12
1	0	1	1	P1	P2	P3	P4	P5	P6	P7	P8	P9	P10	P11	SEG12
1	1	0	0	P1	P2	P3	P4	P5	P6	P7	P8	P9	P10	P11	P12

Note : SEGn(n=1~12) : Segment output pin function, Pn (n=1~12) : General-purpose output pin function

When selected, following data are assigned.

Output port	Corresponding display data
SEG1/ P1	D1
SEG2/ P2	D5
SEG3/ P3	D9
SEG4/ P4	D13
SEG5/ P5	D17
SEG6/ P6	D21

Output port	Corresponding display data
SEG7/ P7	D25
SEG8/ P8	D29
SEG9/ P9	D33
SEG10/ P10	D37
SEG11/ P11	D41
SEG12/ P12	D45

For example, When the general-purpose output pin function is selected for SEGn/Pn output pins, that output pin will output a high level data Dn is "1", and will output a low level when Dn is "0".

## Display Data to Segment Output Pin Correspondence (1)

- 1/3 Duty

Output Pin	COM3	COM2	COM1
SEG1	D1	D2	D3
SEG2	D4	D5	D6
SEG3	D7	D8	D9
SEG4	D10	D11	D12
SEG5	D13	D14	D15
SEG6	D16	D17	D18
SEG7	D19	D20	D21
SEG8	D22	D23	D24
SEG9	D25	D26	D27
SEG10	D28	D29	D30
SEG11	D31	D32	D33
SEG12	D34	D35	D36
SEG13	D37	D38	D39
SEG14	D40	D41	D42
SEG15	D43	D44	D45
SEG16	D46	D47	D48
SEG17	D49	D50	D51
SEG18	D52	D53	D54
SEG19	D55	D56	D57
SEG20	D58	D59	D60
SEG21	D61	D62	D63
SEG22	D64	D65	D66
SEG23	D67	D68	D69
SEG24	D70	D71	D72
SEG25	D73	D74	D75
SEG26	D76	D77	D78

Output Pin	COM3	COM2	COM1
SEG27	D79	D80	D81
SEG28	D82	D83	D84
SEG29	D85	D86	D87
SEG30	D88	D89	D90
SEG31	D91	D92	D93
SEG32	D94	D95	D96
SEG33	D97	D98	D99
SEG34	D100	D101	D102
SEG35	D103	D104	D105
SEG36	D106	D107	D108
SEG37	D109	D110	D111
SEG38	D112	D113	D114
SEG39	D115	D116	D117
SEG40	D118	D119	D120
SEG41	D121	D122	D123
SEG42	D124	D125	D126
SEG43	D127	D128	D129
SEG44	D130	D131	D132
SEG45	D133	D134	D135
SEG46	D136	D137	D138
SEG47	D139	D140	D141
SEG48	D142	D143	D144
SEG49	D145	D146	D147
SEG50	D148	D149	D150
SEG51	D151	D152	D153
SEG52	D154	D155	D156

Note : When Display Data is "1", the Segment ON. When Display Data is "0", the Segment OFF

## Display Data to Segment Output Pin Correspondence (2)

- 1/4 Duty

Output Pin	COM3	COM2	COM1	COM0
SEG1/ P1	D1	D2	D3	D4
SEG2/ P2	D5	D6	D7	D8
SEG3/ P3	D9	D10	D11	D12
SEG4/ P4	D13	D14	D15	D16
SEG5/ P5	D17	D18	D19	D20
SEG6/ P6	D21	D22	D23	D24
SEG7/ P7	D25	D26	D27	D28
SEG8/ P8	D29	D30	D31	D32
SEG9/ P9	D33	D34	D35	D36
SEG10/ P10	D37	D38	D39	D40
SEG11/ P11	D41	D42	D43	D44
SEG12/ P12	D45	D46	D47	D48
SEG13	D49	D50	D51	D52
SEG14	D53	D54	D55	D56
SEG15	D57	D58	D59	D60
SEG16	D61	D62	D63	D64
SEG17	D65	D66	D67	D68
SEG18	D69	D70	D71	D72
SEG19	D73	D74	D75	D76
SEG20	D77	D78	D79	D80
SEG21	D81	D82	D83	D84
SEG22	D85	D86	D87	D88
SEG23	D89	D90	D91	D92
SEG24	D93	D94	D95	D96
SEG25	D97	D98	D99	D100
SEG26	D101	D102	D103	D104

Output Pin	COM3	COM2	COM1	COM0
SEG27	D105	D106	D107	D108
SEG28	D109	D110	D111	D112
SEG29	D113	D114	D115	D116
SEG30	D117	D118	D119	D120
SEG31	D121	D122	D123	D124
SEG32	D125	D126	D127	D128
SEG33	D129	D130	D131	D132
SEG34	D133	D134	D135	D136
SEG35	D137	D138	D139	D140
SEG36	D141	D142	D143	D144
SEG37	D145	D146	D147	D148
SEG38	D149	D150	D151	D152
SEG39	D153	D154	D155	D156
SEG40	D157	D158	D159	D160
SEG41	D161	D162	D163	D164
SEG42	D165	D166	D167	D168
SEG43	D169	D170	D171	D172
SEG44	D173	D174	D175	D176
SEG45	D177	D178	D179	D180
SEG46	D181	D182	D183	D184
SEG47	D185	D186	D187	D188
SEG48	D189	D190	D191	D192
SEG49	D193	D194	D195	D196
SEG50	D197	D198	D199	D200
SEG51	D201	D202	D203	D204

Note : When Display Data is "1", the Segment ON. When Display Data is "0", the Segment OFF



LCD Driving Waveform (1)

- 1/3 Duty, 1/3 Bias and 1/2 Bias

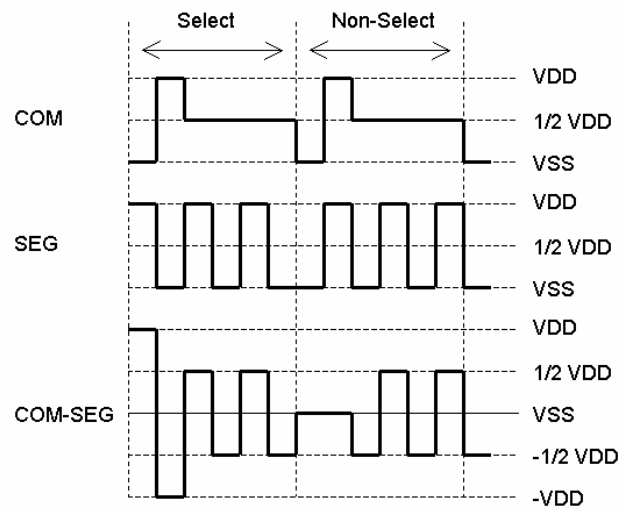
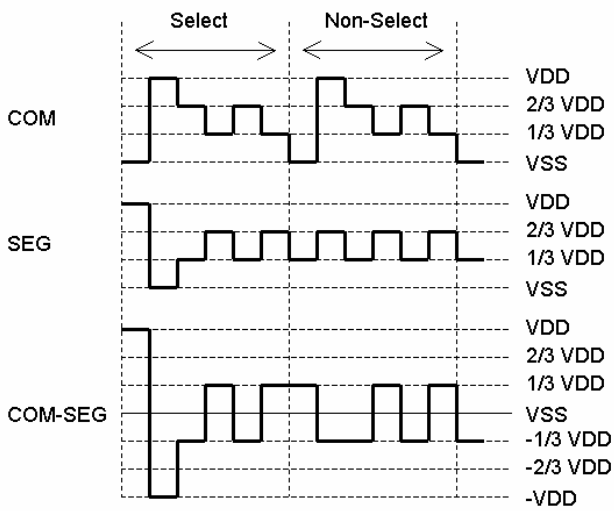
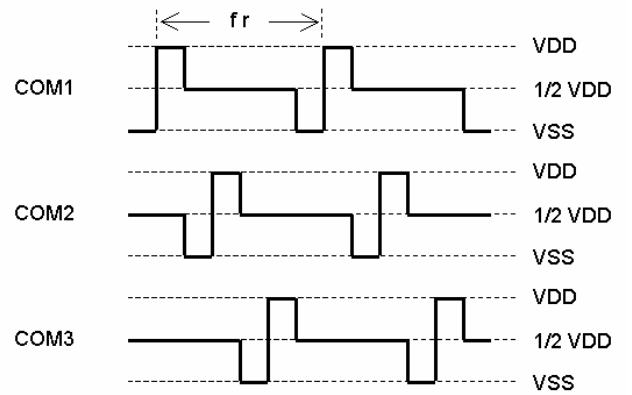
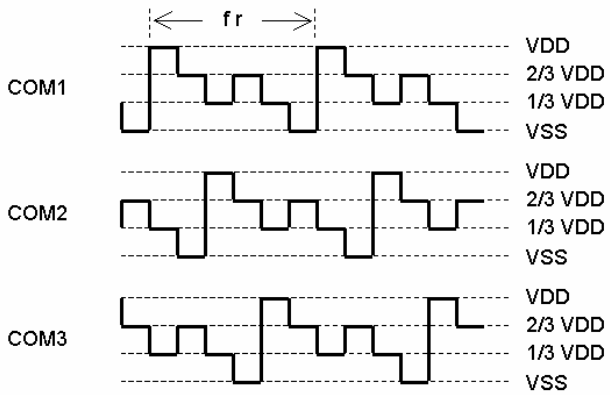

Note : Frame frequency  $f_r = f_{osc} / 384 \text{ Hz}$

LCD Driving Waveform (2)

- 1/4 Duty, 1/3 Bias and 1/2 Bias

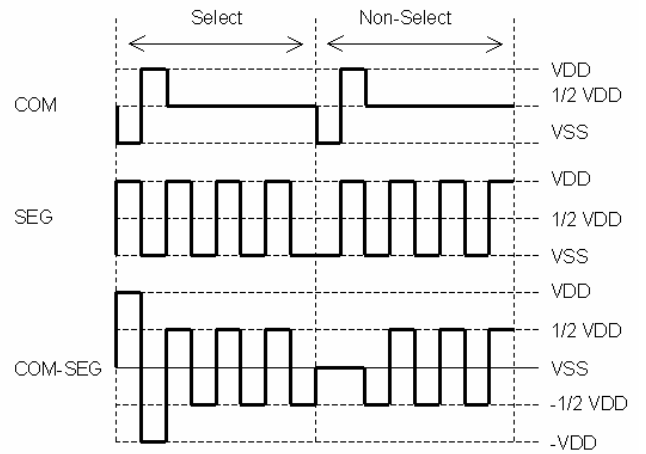
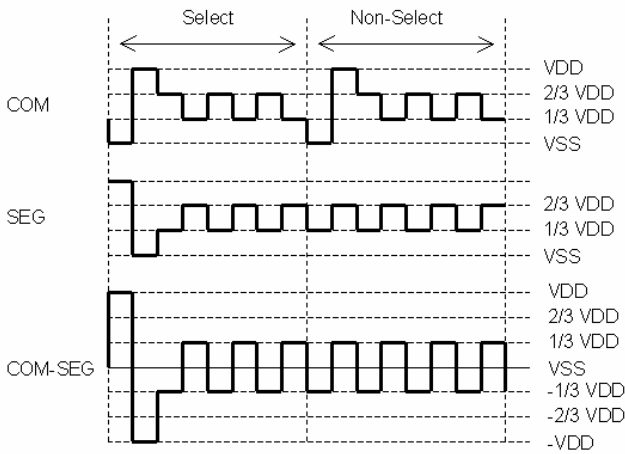
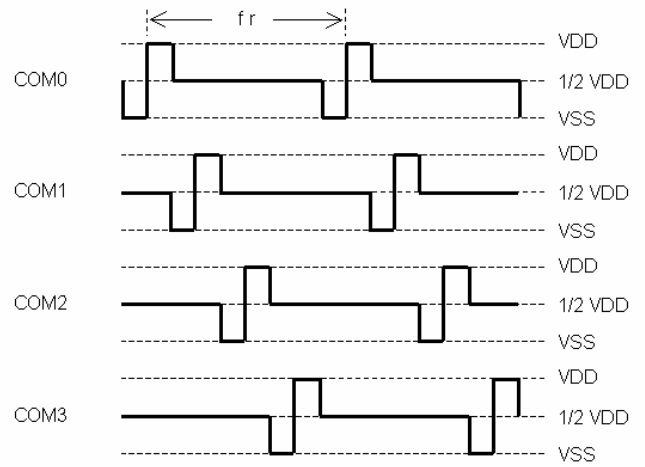
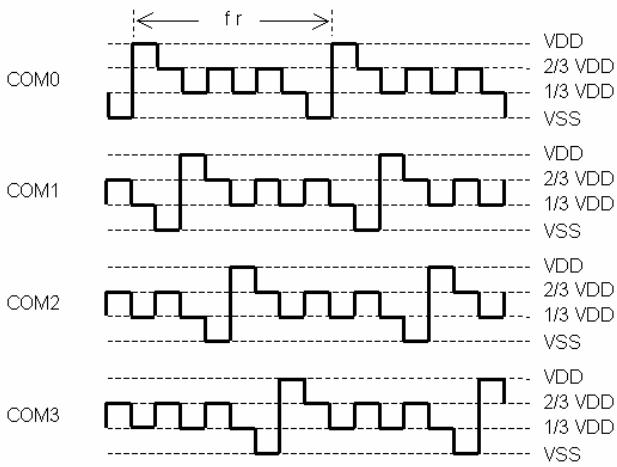

Note : Frame frequency  $fr = f_{osc} / 512 \text{ Hz}$

Application Circuit (1)

**1/3 Duty, 1/3 Bias (For Small LCD Panels )**

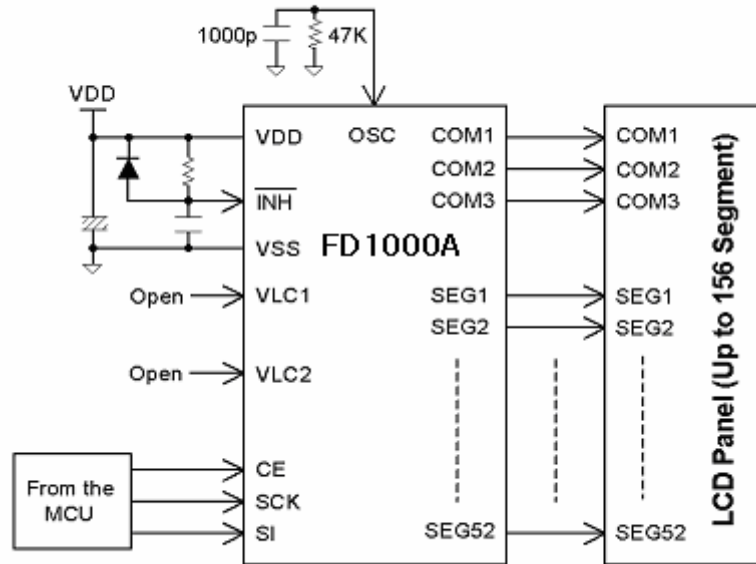

**1/3 Duty, 1/3 Bias (For Normal LCD Panels )**

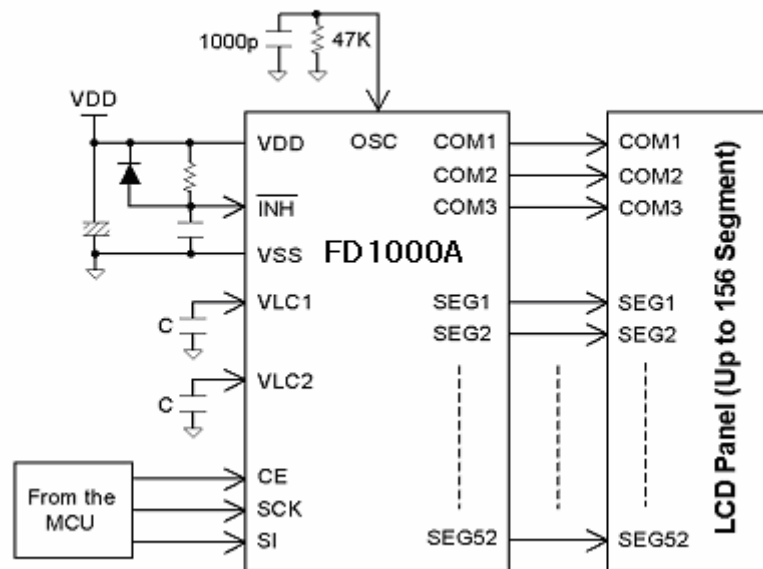

Note : C=0.047uF~

Application Circuit (2)

**1/3 Duty, 1/3 Bias (For Large LCD Panels )**

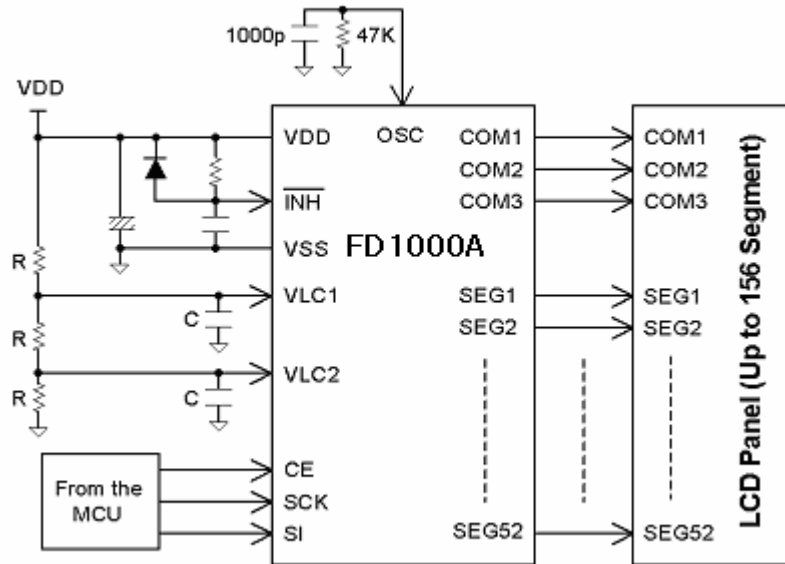

Note : R=1K ~ 10K, C=0.047uF~

**1/3 Duty, 1/2 Bias (For Normal LCD Panels )**

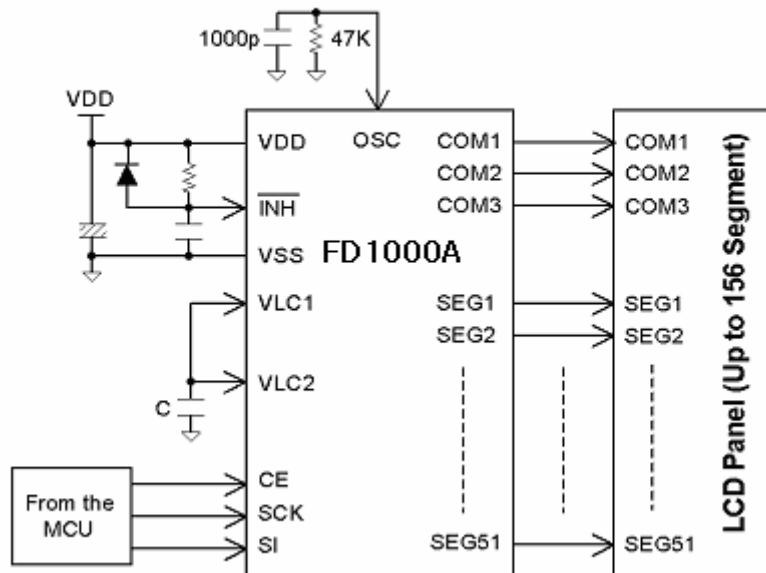

Note : C=0.047uF~

Application Circuit (3)

**1/3 Duty, 1/2 Bias (For Large LCD Panels )**

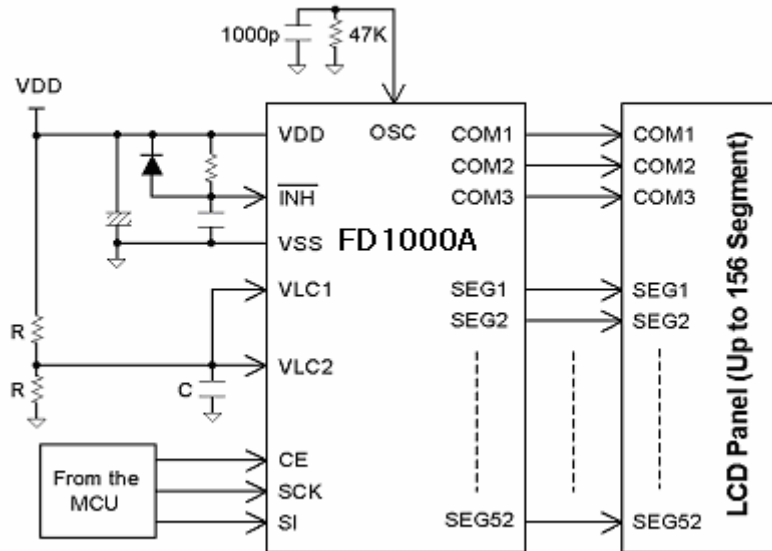

Note : R=1K ~ 10K, C=0.047uF~

**1/3 Duty, 1/2 Bias (For Small LCD Panels ) & INH\ Control**

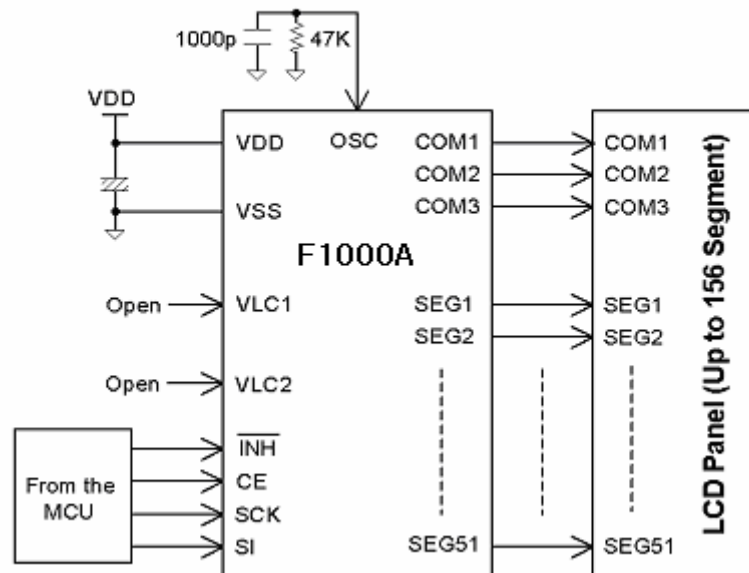

Application Circuit (4)

1/4 Duty, 1/3 Bias (For Small LCD Panels )

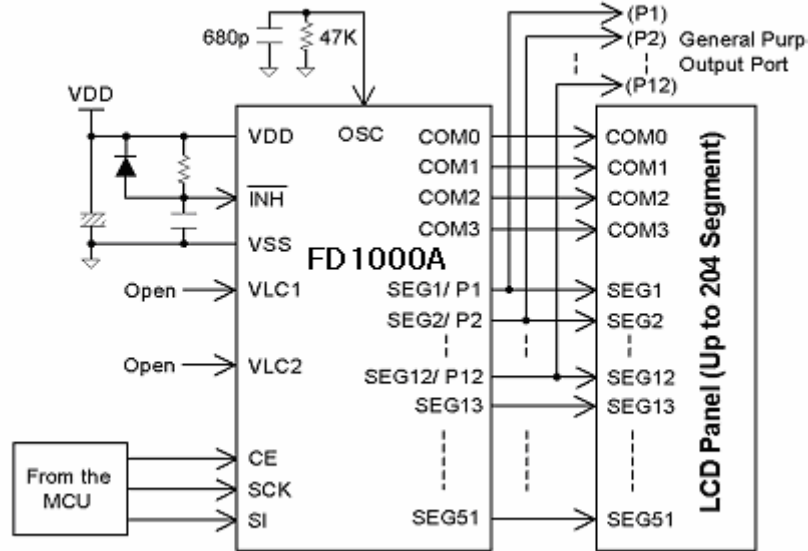

1/4 Duty, 1/3 Bias (For Normal LCD Panels )

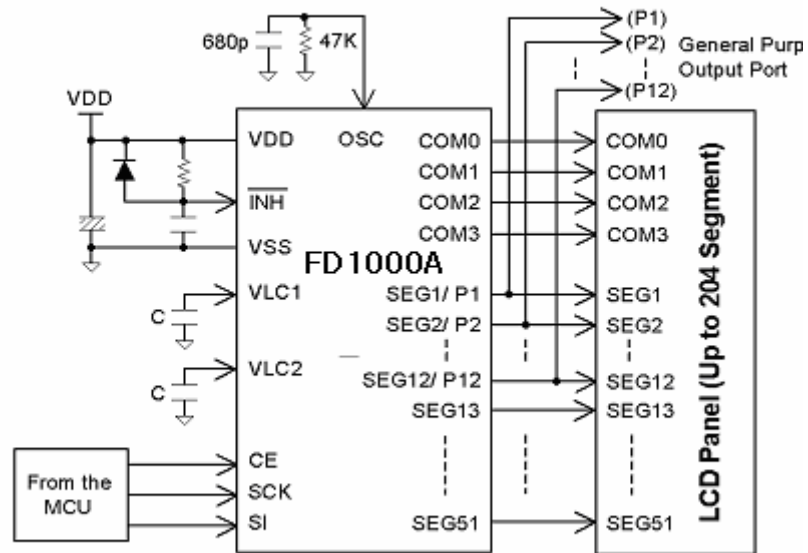

Note : C=0.047uF~

## Application Circuit (5)

### 1/4 Duty, 1/3 Bias (For Large LCD Panels )

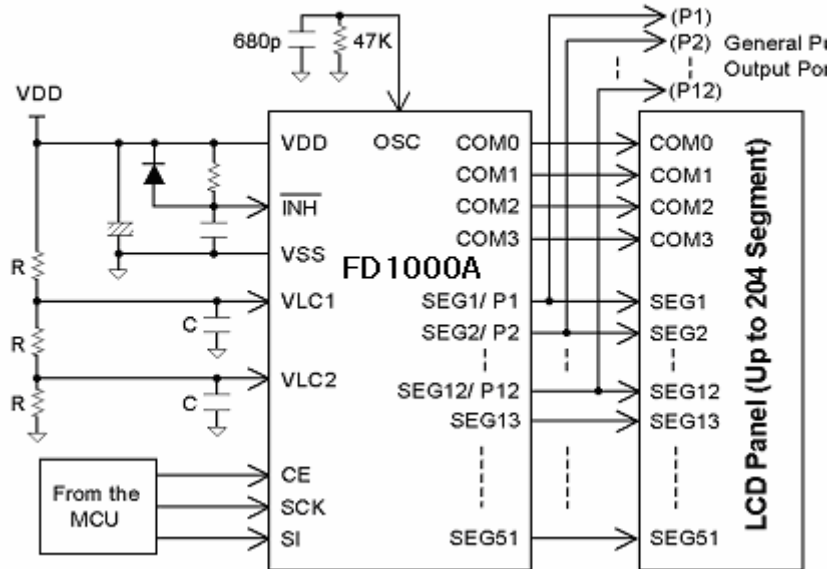

Note : R=1K ~ 10K, C=0.047uF~

### 1/4 Duty, 1/2 Bias (For Normal LCD Panels )

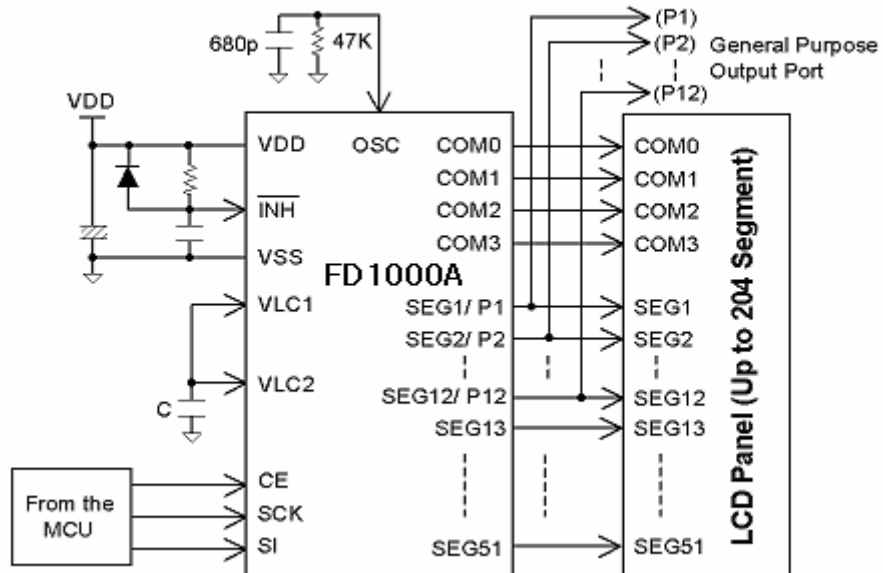

Note : C=0.047uF~

Application Circuit (6)

**1/4 Duty, 1/2 Bias (For Large LCD Panels )**

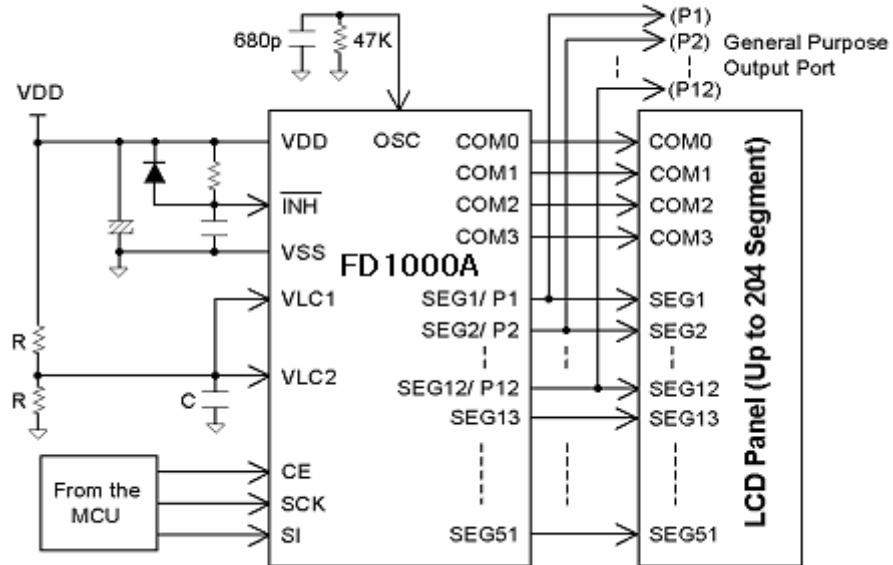

Note : R=1K ~ 10K, C=0.047uF~

**1/4 Duty, 1/2 Bias (For Small LCD Panels ) & INH Control**

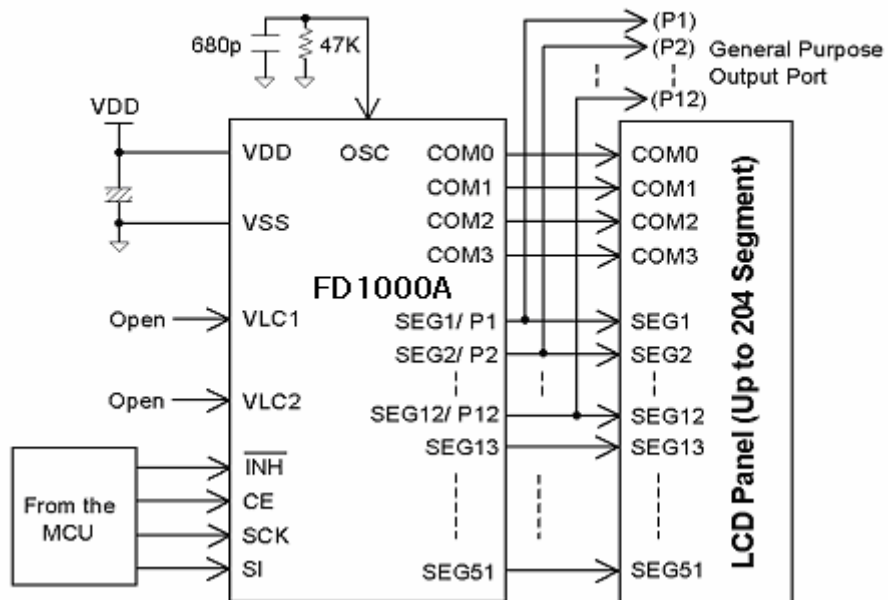



**$\overline{\text{INH}}$  Pin and Display Control**

Since the FD1000A internal data (the display data D1 to D156/D204 and the control data) is undefined when power is first supplied, the display is off (SEG1 to SEG52 and COM1 to COM3=Low). By setting the  $\overline{\text{INH}}$  pin low at the same time as power is supplied.

While the  $\overline{\text{INH}}$  pin is held low, the micro-controller should send the serial data and set  $\overline{\text{INH}}$  pin high after the transfer completes.

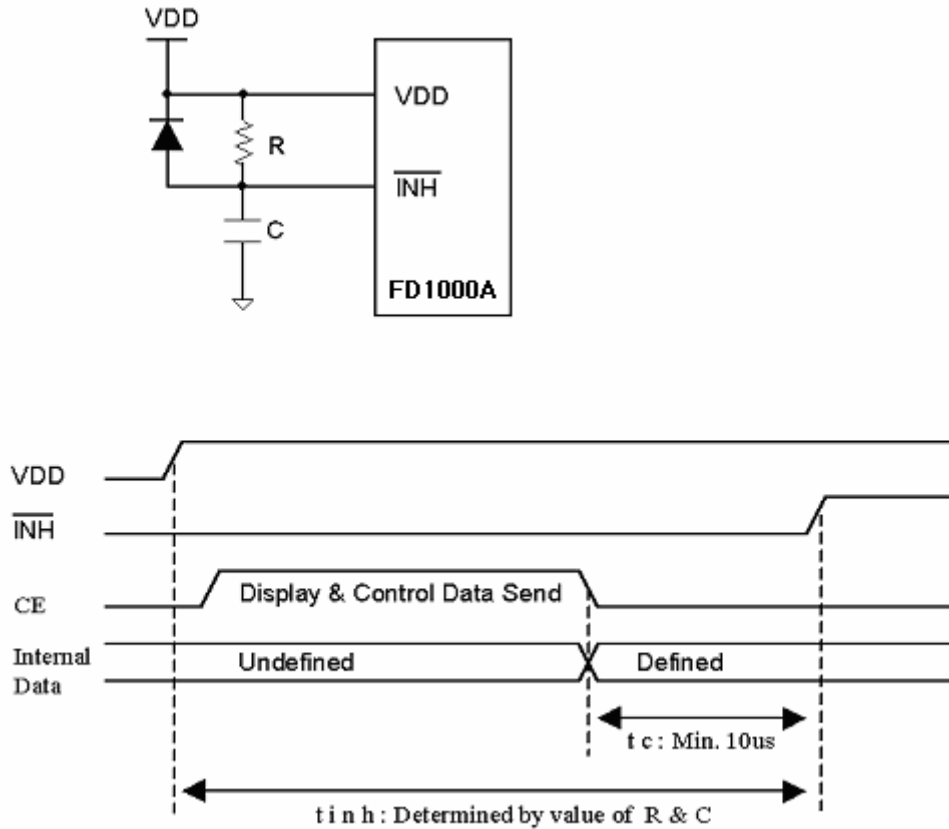

**Figure 1**

**Absolute Maximum Ratings**

(T<sub>A</sub> = 25°C)

Parameter	Symbol	Conditions	Ratings	Unit
Supply voltage	V <sub>DD</sub>	V <sub>DD</sub>	- 0.3 to +6.0	V
Input voltage	V <sub>I</sub>	CE, SCK,SI ,OSC and INH\	- 0.3 to V <sub>DD</sub> + 0.3	V
Output voltage	V <sub>O</sub>	SEG1~SEG52, COM1~COM3	- 0.3 to V <sub>DD</sub> + 0.3	V
Output current	I <sub>out1</sub>	SEG1 to SEG52	0.3	mA
	I <sub>out2</sub>	COM0 to COM4	3	
	I <sub>out3</sub>	P1 to P12	10	
Operating temperature	T <sub>A</sub>		- 40 to + 85	°C
Storage temperature	T <sub>STG</sub>		- 55 to + 125	

**D.C Electrical Characteristics**

(T<sub>A</sub> = - 40 °C to + 85 °C, V<sub>SS</sub> = 0 V, V<sub>DD</sub> = 2.7 V to 5.5 V)

Parameter	Symbol	Conditions	Min	Typ	Max	Unit
Operating voltage	V <sub>DD</sub>	V <sub>DD</sub>	2.7	-	5.5	V
Input high leakage	I <sub>IH</sub>	CE, SCK,SI and INH\ : Vi = 5V	-	-	5	uA
Input low leakage	I <sub>IL</sub>	CE, SCK,SI and INH\ : Vi = 0V	-5	-	-	uA
Input high voltage	V <sub>IH</sub>	CE, SCK,SI and INH\ , V <sub>DD</sub> = 5V	2.7	-	V <sub>DD</sub>	V
Input low voltage	V <sub>IL</sub>	CE, SCK,SI and INH\ , V <sub>DD</sub> = 5V	-	-	0.5	V
Input voltage	V <sub>LC1</sub>	VLC1	-	2/3 V <sub>DD</sub>	-	V
	V <sub>LC2</sub>	VLC2	-	1/3 V <sub>DD</sub>	-	
Output high voltage	V <sub>OH1</sub>	SEG1 ~ SEG52 : lo = -20uA	V <sub>DD</sub> -1.0	-	-	V
	V <sub>OH2</sub>	COM0 to COM3 : lo = -100uA	V <sub>DD</sub> -1.0	-	-	
	V <sub>OH3</sub>	P1 to P12 : lo = -1.5mA , V <sub>DD</sub> = 5V	V <sub>DD</sub> -1.0	-	-	
Output low voltage	V <sub>OL1</sub>	SEG1 ~ SEG52 : lo = 20uA	-	-	1.0	V
	V <sub>OL2</sub>	COM0 to COM3 : lo = 100uA	-	-	1.0	
	V <sub>OL3</sub>	P1 to P12 : lo = 3mA , V <sub>DD</sub> = 5V	-	-	1.0	
Supply current	I <sub>DD1</sub>	Stop mode , V <sub>DD</sub> = 5V T <sub>A</sub> = 25 °C			5	uA
	I <sub>DD2</sub>	f=38Khz, 1/3 duty, 1/2bias, V <sub>DD</sub> = 5V	-	300	600	uA
	I <sub>DD3</sub>	f=38Khz, 1/3 duty, 1/3bias, V <sub>DD</sub> = 5V	-	250	500	uA
	I <sub>DD4</sub>	f=51Khz, 1/4 duty, 1/2bias, V <sub>DD</sub> = 5V Output open, Control Data CU = 0	-	300	600	uA
	I <sub>DD5</sub>	f=51Khz, 1/4 duty, 1/2bias, V <sub>DD</sub> = 5V Output open, Control Data CU = 1	-	250	500	uA
	I <sub>DD6</sub>	f=51Khz, 1/4 duty, 1/3bias, V <sub>DD</sub> = 5V Output open, Control Data CU = 0	-	250	500	uA
	I <sub>DD7</sub>	f=51Khz, 1/4 duty, 1/3bias, V <sub>DD</sub> = 5V Output open, Control Data CU = 1	-	200	400	uA

## A.C Electrical Characteristics

( $T_A = -40\text{ }^{\circ}\text{C}$  to  $+85\text{ }^{\circ}\text{C}$ ,  $V_{DD} = 4.0\text{ V}$  to  $5.5\text{ V}$ )

Parameter	Symbol	Conditions	Min	Typ	Max	Unit
Oscillator frequency	fosc1	Vdd=5V, 1/3 Duty:Rosc=47K, Cosc=1000pF	28	38	48	Khz
	fosc2	Vdd=5V, 1/4 Duty:Rosc=47K, Cosc=680pF	41	51	61	Khz
Data setup time	tds	Figure2 : SI, SCK	160	-	-	ns
Data hold time	tdh	Figure2 : SI, SCK	160	-	-	ns
High level Clock pulse width	twh	Figure2 : SCK	160	-	-	ns
Low level Clock pulse width	twl	Figure2 : SCK	160	-	-	ns
CE setup time	tcs	Figure2 : SCK, CE	160	-	-	ns
CE hold time	tch	Figure2 : SCK, CE	160	-	-	ns
CE wait time	tcw	Figure2 : SCK, CE	160	-	-	ns
Rise time	tr	$V_{IL}$ to $V_{IH}$ : SI, SCK, CE, INH	-	160	-	ns
Fall time	tf	$V_{IH}$ to $V_{IL}$ : SI, SCK, CE, INH	-	160	-	ns
INH\ switching time	tc	Figure1 : INH\, CE	10	-	-	us

- When SCK is stopped at the low level

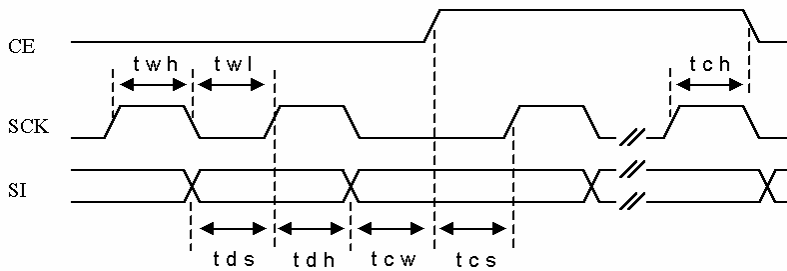

- When SCK is stopped at the high level

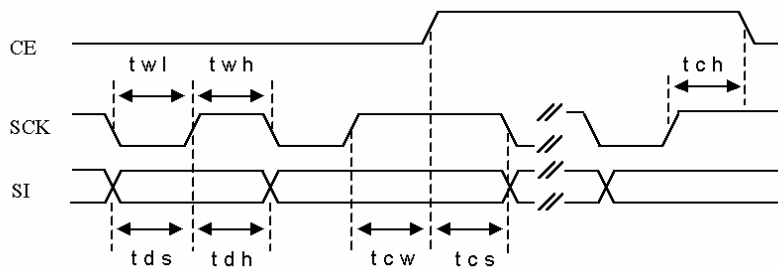
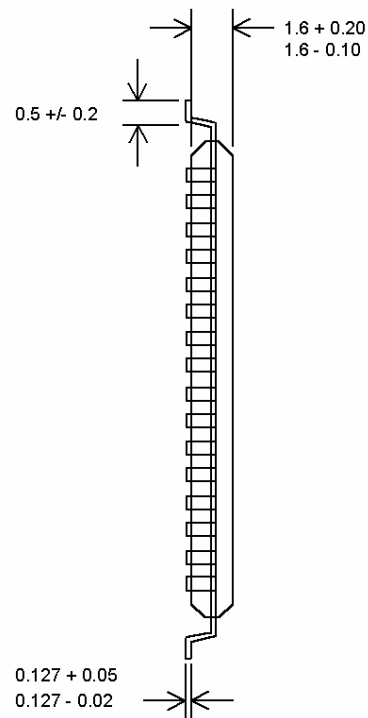
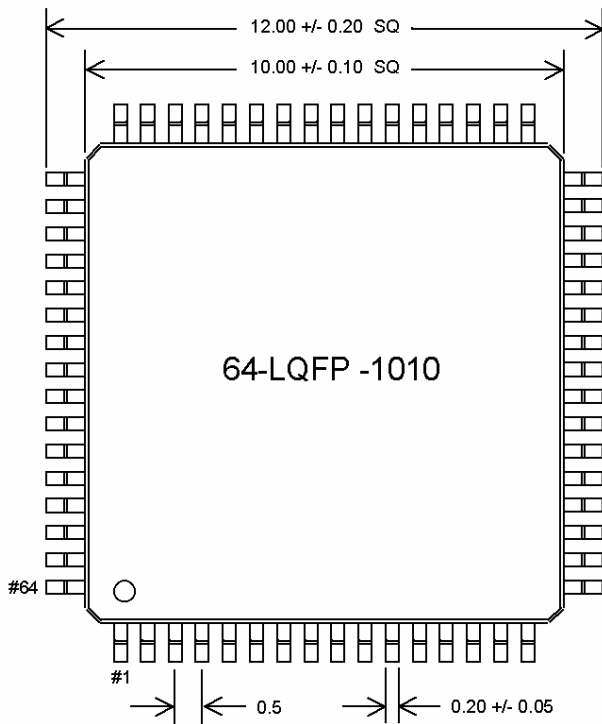
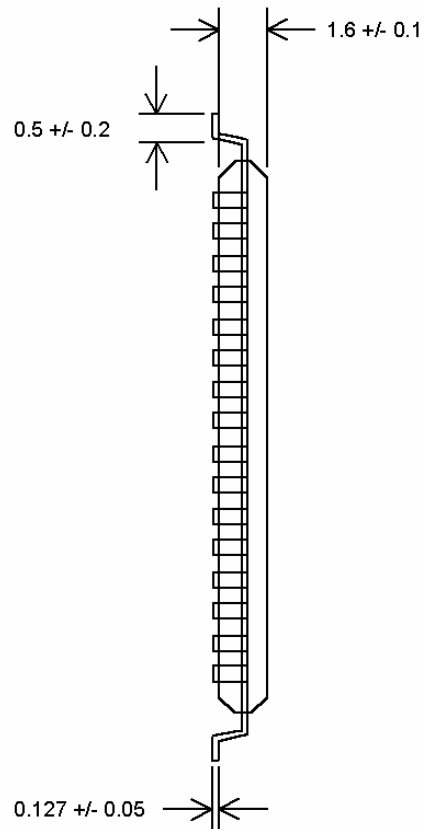
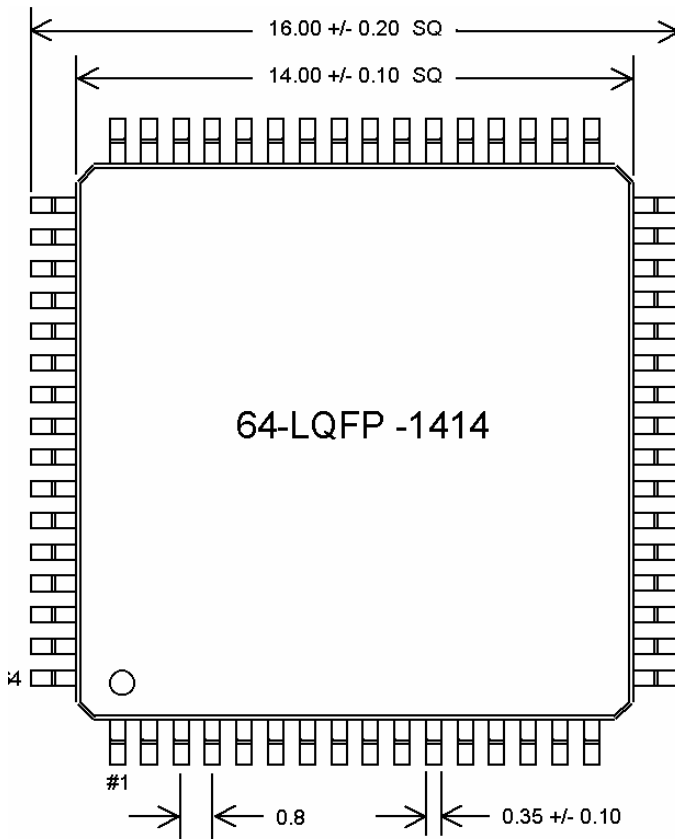

Figure 2

Package Dimensions



Unit : mm