

isc Silicon NPN Darlington Power Transistor

2SD2558

DESCRIPTION

- Collector-Emitter Breakdown Voltage-  
:  $V_{(BR)CEO} = 200V(\text{Min})$
- High DC Current Gain-  
:  $h_{FE} = 1500(\text{Min.}) @ (I_C = 1A, V_{CE} = 5V)$
- Low Collector Saturation Voltage-  
:  $V_{CE(sat)} = 1.5V(\text{Max}) @ (I_C = 1A, I_B = 5mA)$

APPLICATIONS

- Designed for series regulator and general purpose applications.

ABSOLUTE MAXIMUM RATINGS( $T_a=25^\circ C$ )

SYMBOL	PARAMETER	VALUE	UNIT
$V_{CBO}$	Collector-Base Voltage	200	V
$V_{CEO}$	Collector-Emitter Voltage	200	V
$V_{EBO}$	Emitter-Base Voltage	6	V
$I_C$	Collector Current-Continuous	5	A
$I_B$	Base Current-Continuous	2	A
$P_C$	Collector Power Dissipation @ $T_C=25^\circ C$	60	W
$T_J$	Junction Temperature	150	$^\circ C$
$T_{stg}$	Storage Temperature	-55~150	$^\circ C$

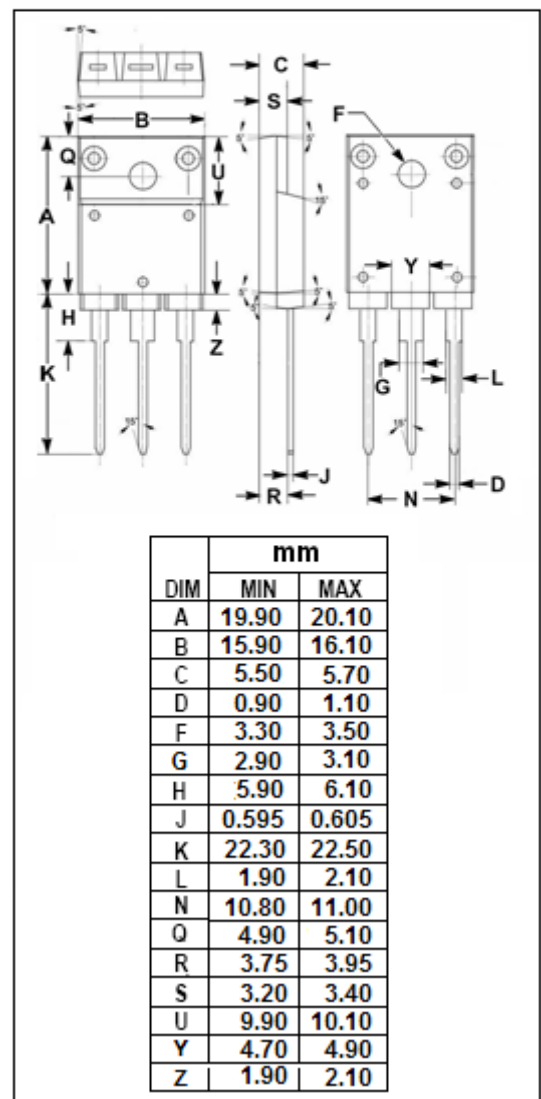
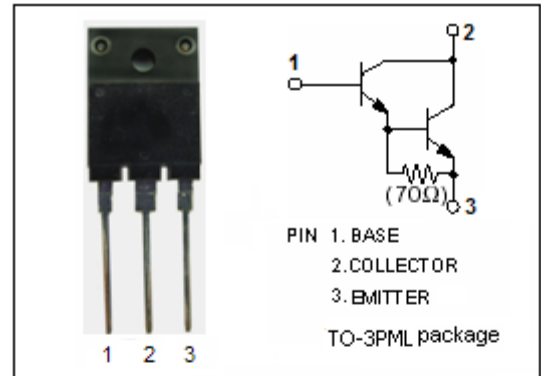

**isc Silicon NPN Darlington Power Transistor****2SD2558****ELECTRICAL CHARACTERISTICS****T<sub>j</sub>=25°C unless otherwise specified**

SYMBOL	PARAMETER	CONDITIONS	MIN	TYP.	MAX	UNIT
V <sub>(BR)CEO</sub>	Collector-Emitter Breakdown Voltage	I <sub>C</sub> = 10mA, I <sub>B</sub> = 0	200			V
V <sub>CE(sat)</sub>	Collector-Emitter Saturation Voltage	I <sub>C</sub> = 1A, I <sub>B</sub> = 5mA			1.5	V
I <sub>CBO</sub>	Collector Cutoff current	V <sub>CB</sub> = 200V, I <sub>E</sub> = 0			0.1	mA
I <sub>EBO</sub>	Emitter Cutoff current	V <sub>EB</sub> = 6V, I <sub>C</sub> = 0			5.0	mA
h <sub>FE</sub>	DC Current Gain	I <sub>C</sub> = 1A; V <sub>CE</sub> = 5V	1500		6500	
C <sub>OB</sub>	Output Capacitance	I <sub>E</sub> = 0; V <sub>CB</sub> = 10V; f <sub>test</sub> = 1MHz		110		pF
f <sub>T</sub>	Current-Gain—Bandwidth Product	I <sub>E</sub> = -0.5A; V <sub>CE</sub> = 10V		15		MHz