



# TPB SERIES

TRISIL™

## FEATURES

- BIDIRECTIONAL CROWBAR PROTECTION.
- VOLTAGE RANGE: FROM 62 V TO 270 V.
- HOLDING CURRENT :  
 $I_H = 150\text{mA min.}$
- REPETITIVE PEAK PULSE CURRENT :  
 $I_{PP} = 100\text{ A, } 10/1000\ \mu\text{s.}$
- UL RECOGNIZED FILE # E136224

## DESCRIPTION

The TPB series are TRISIL devices especially designed for protecting sensitive telecommunication equipment against lightning and transient voltages induced by AC power lines. They are available in the CB429 axial package.

TRISIL devices provide bidirectional protection by crowbar action. Their characteristic response to transient overvoltages makes them particularly suited to protect voltage sensitive telecommunication equipment.

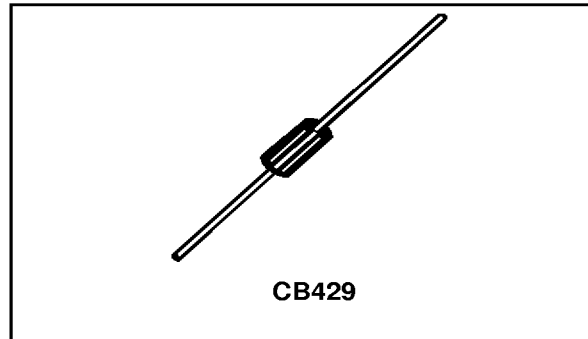

## SCHEMATIC DIAGRAM

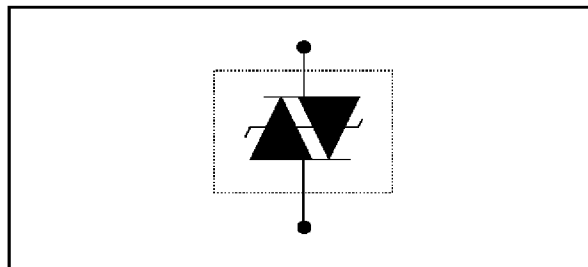

COMPLIES WITH THE FOLLOWING STANDARDS:	Peak Surge Voltage (V)	Voltage Waveform ( $\mu\text{s}$ )	Current Waveform ( $\mu\text{s}$ )	Admissible $I_{pp}$ (A)	Necessary Resistor ( $\Omega$ )
CCITT K20	4000	10/700	5/310	100	-
VDE0433	4000	10/700	5/310	100	-
VDE0878	4000	1.2/50	1/20	100	-
IEC-1000-4-5	level 4 level 4	10/700 1.2/50	5/310 8/20	100 100	- -
FCC Part 68, lightning surge type A	1500 800	10/160 10/560	10/160 10/560	200 100	- -
FCC Part 68, lightning surge type B	100	5/320	5/320	25	-
BELLCORE TR-NWT-001089 First level	2500 1000	2/10 10/1000	2/10 10/1000	500 100	- -
BELLCORE TR-NWT-001089 Second level	500	2/10	2/10	500	-
CNET I31-24	4000	0.5/700	0.8/310	100	-

## TPB SERIES

### ABSOLUTE MAXIMUM RATINGS ( $T_{amb} = 25^{\circ}\text{C}$ )

Symbol	Parameter	Value	Unit
P	Power dissipation on infinite heatsink	$T_{amb} = 50^{\circ}\text{C}$	5 W
$I_{PP}$	Peak pulse current	10/1000 $\mu\text{s}$ 8/20 $\mu\text{s}$ 2/10 $\mu\text{s}$	100 150 500 A
$I_{TSM}$	Non repetitive surge peak on-state current	$t_p = 20\text{ ms}$	50 A
$I^2t$	$I^2t$ value for fusing	$t_p = 20\text{ ms}$	25 $\text{A}^2\text{s}$
dV/dt	Critical rate of rise of off-state voltage	$V_{RM}$	5 $\text{kV}/\mu\text{s}$
$T_{stg}$ $T_j$	Storage temperature range Maximum junction temperature		- 55 to + 150 150 $^{\circ}\text{C}$
$T_L$	Maximum lead temperature for soldering during 10s at 5mm for case		230 $^{\circ}\text{C}$

### THERMAL RESISTANCES

Symbol	Parameter	Value	Unit
$R_{th(j-l)}$	Junction to leads ( $L_{lead} = 10\text{mm}$ )	20	$^{\circ}\text{C}/\text{W}$
$R_{th(j-a)}$	Junction to ambient on printed circuit ( $L_{lead} = 10\text{ mm}$ )	75	$^{\circ}\text{C}/\text{W}$

### ELECTRICAL CHARACTERISTICS

( $T_{amb} = 25^{\circ}\text{C}$ )

Symbol	Parameter
$V_{RM}$	Stand-off voltage
$I_{RM}$	Leakage current at stand-off voltage
$V_R$	Continuous Reverse voltage
$V_{BR}$	Breakdown voltage
$V_{BO}$	Breakover voltage
$I_H$	Holding current
$I_{BO}$	Breakover current
$I_{PP}$	Peak pulse current
C	Capacitance

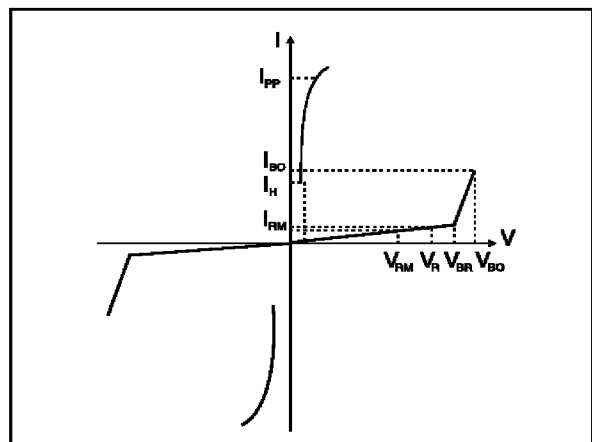

Type	$I_{RM} @ V_{RM}$ max.		$I_R @ V_R$ max. note1		$V_{BO} @ I_{BO}$ max. note2		$I_H$ min. note3	$C$ max. note4
	$\mu\text{A}$	V	$\mu\text{A}$	V	V	mA	mA	pF
TPB62	2	56	50	62	82	800	150	300
TPB68	2	61	50	68	90	800	150	300
TPB100	2	90	50	100	133	800	150	200
TPB120	2	108	50	120	160	800	150	200
TPB130	2	117	50	130	173	800	150	200
TPB180	2	162	50	180	240	800	150	200
TPB200	2	180	50	200	267	800	150	200
TPB220	2	198	50	220	293	800	150	200
TPB240	2	216	50	240	320	800	150	200
TPB270	2	243	50	270	360	800	150	200

**Note 1:**  $I_R$  measured at  $V_R$  guarantees  $V_{BRmin} \geq V_R$

**Note 3:** See test circuit 2.

**Note 2:** Measured at 50 Hz (1 cycle) - See test circuit 1.

**Note 4:**  $V_R = 1\text{V}$ ,  $F = 1\text{MHz}$ , refer to fig.3 for C versus  $V_R$

**TEST CIRCUIT 1 FOR  $I_{BO}$  and  $V_{BO}$  parameters:**

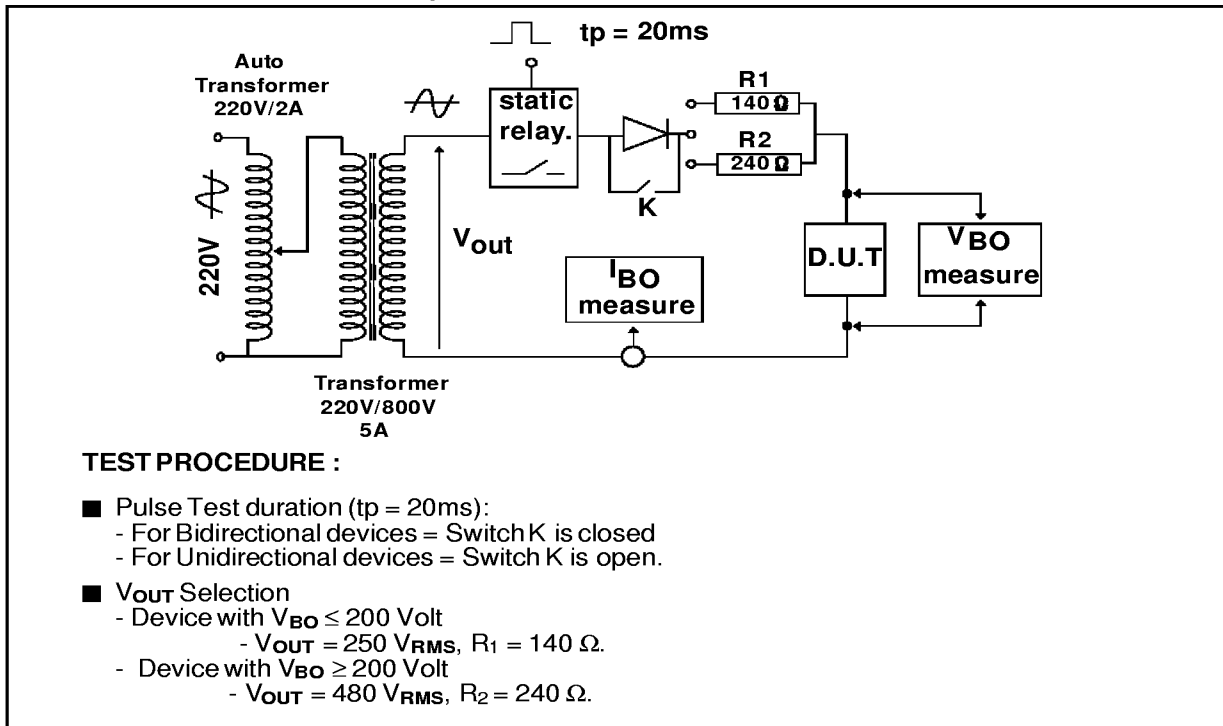

**TEST CIRCUIT 2 for  $I_H$  parameter**

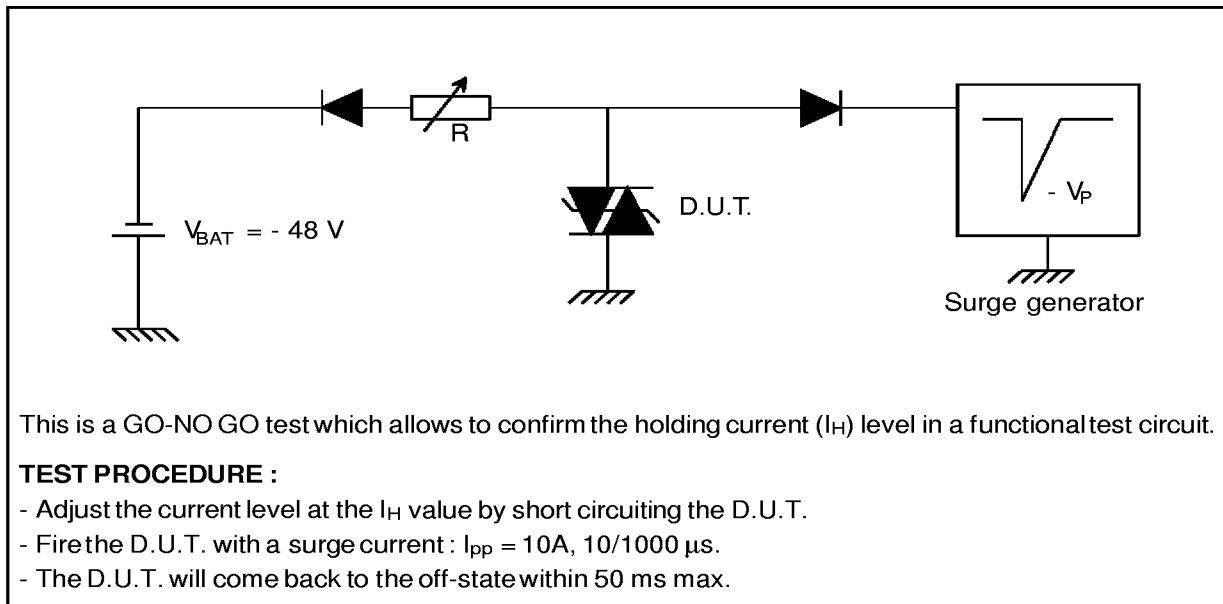

## TPB SERIES

**Fig. 1:** Non repetitive surge peak on-state current versus overload duration ( $T_j$  initial=25°C).

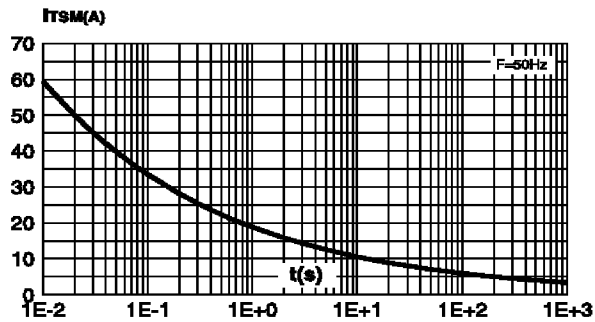

**Fig. 2:** Relative variation of holding current versus junction temperature.

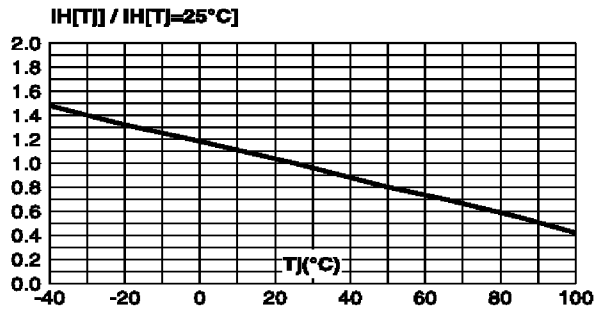

**Fig. 3:** Relative variation of junction capacitance versus reverse applied voltage (typical values). Note: For  $V_{RM}$  upper than 56V, the curve is extrapolated (dotted line).

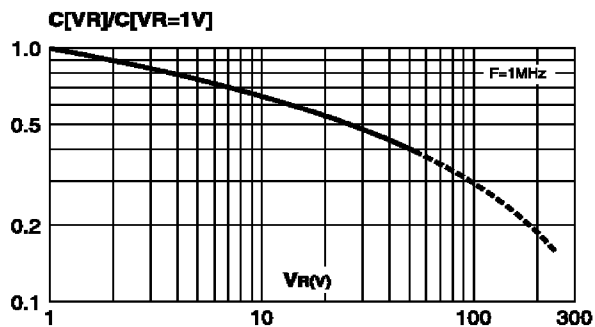

**Fig. 4:** On-state current versus on-state voltage (typical values).

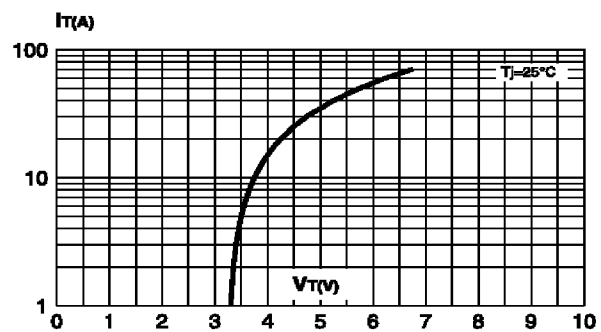

**Fig. 5:** Transient thermal impedance junction to ambient versus pulse duration (for FR4 PC Board with  $T_{Lead} = 10$  mm).

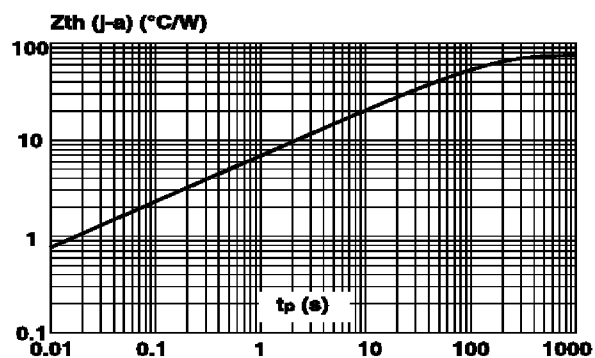

ORDER CODE

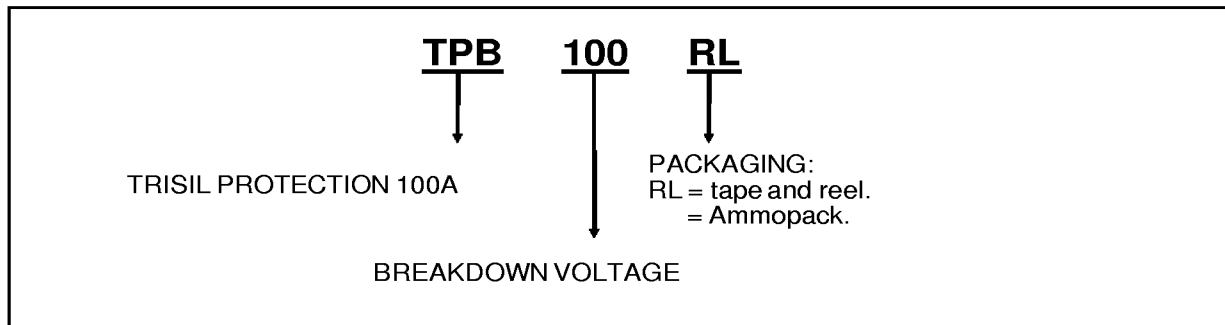

**MARKING** : Logo, Date Code, Part Number.

**PACKAGE MECHANICAL DATA.**  
CB429 Plastic

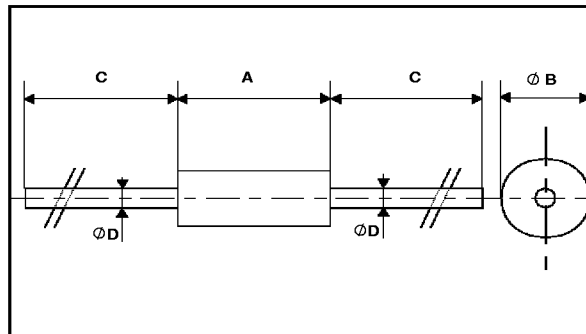

REF.	DIMENSIONS					
	Millimeters			Inches		
	Min.	Typ.	Max.	Min.	Typ.	Max.
A	9.45	9.50	9.80	0.372	0.374	0.386
B	26			1.024		
∅ C	4.90	5.00	5.10	0.193	0.197	0.201
∅ D	0.94	1.00	1.06	0.037	0.039	0.042
L1			1.27			0.050
<b>note 1</b> : the lead is not controlled in zone L1						

**Packaging** : Standard packaging is in tape and reel.

**Weight** : 0.85g

Information furnished is believed to be accurate and reliable. However, STMicroelectronics assumes no responsibility for the consequences of use of such information nor for any infringement of patents or other rights of third parties which may result from its use. No license is granted by implication or otherwise under any patent or patent rights of STMicroelectronics. Specifications mentioned in this publication are subject to change without notice. This publication supersedes and replaces all information previously supplied. STMicroelectronics products are not authorized for use as critical components in life support devices or systems without express written approval of STMicroelectronics.

The ST logo is a registered trademark of STMicroelectronics

© 1998 STMicroelectronics - Printed in Italy - All rights reserved.

STMicroelectronics GROUP OF COMPANIES

Australia - Brazil - Canada - China - France - Germany - Italy - Japan - Korea - Malaysia - Malta - Mexico - Morocco - The Netherlands - Singapore - Spain - Sweden - Switzerland - Taiwan - Thailand - United Kingdom - U.S.A.

<http://www.st.com>

