

# NCN9252

## High-Speed USB 2.0 (480 Mbps) DP3T Switch for USB/UART/Data Multiplexing

### Brief Description

The NCN9252 is a DP3T switch for combined UART and USB 2.0 high-speed data applications. It allows portable systems to use a single external port to transmit and receive signals to and from three separate locations within the portable system. It is comprised of two switches, each with a single common I/O that alternates between 3 terminals. They are operated together to allow three data sources, such as a USB or UART transceiver, to pass differential data through a shared USB connector port.

The NCN9252 features low  $R_{ON}$ — 4  $\Omega$  (max) at 4.2 V  $V_{CC}$ , 5  $\Omega$  (typ) at a 3.3 V  $V_{CC}$ . It also features low  $C_{ON}$ , < 30 pF (max) across the supply voltage range. This performance makes it ideal for both USB full-speed and high-speed applications that require both low  $R_{ON}$  and  $C_{ON}$  for effective signal transmission.

The NCN9252 is capable of accepting control input signals down to 1.4 V, over a range of  $V_{CC}$  supply voltages with minimal leakage current. The NCN9252 is offered in a Pb-Free, 12 pin, 1.7 x 2.0 x 0.5 mm, UQFN package. An Evaluation Board specifically designed for the NCN9252 is available and features USB connectors and test points to allow straightforward testing of the device. Please see part number NCN9252MUGEVB.

### Features

- USB 2.0 Signal Routing
- -3 dB Bandwidth: 525 MHz
- $R_{ON}$ : 4  $\Omega$  Max @  $V_{CC}$  = 4.2 V
- $C_{ON}$ : < 20 pF @  $V_{CC}$  = 3.3 V
- OVT Protection up to 5.25 V on Common Pins
- $V_{CC}$  Range: 1.65 V to 4.5 V
- 3 kV ESD Protection
- 1.7 x 2.0 x 0.5 mm UQFN12 Package
- This is a Pb-Free Device

### Typical Applications

- USB/UART/Data Multiplexing
- Shared USB Connector
- Mobile Phones
- Portable Devices



ON Semiconductor®

<http://onsemi.com>



1  
UQFN12  
MU SUFFIX  
CASE 523AE

### MARKING DIAGRAM

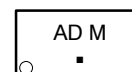

AD = Specific Device Code  
M = Date Code  
■ = Pb-Free Package

### APPLICATION DIAGRAM

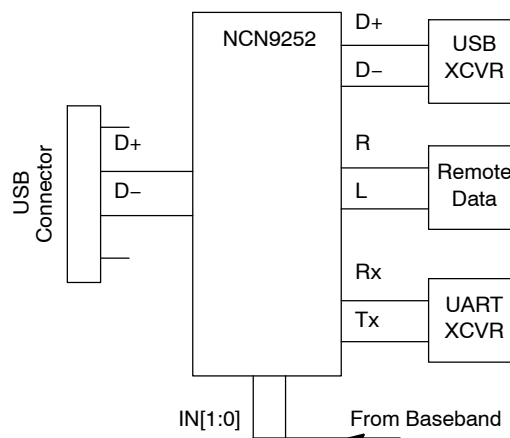

### ORDERING INFORMATION

Device	Package	Shipping†
NCN9252MUTAG	UQFN12 (Pb-Free)	3000 / Tape & Reel

†For information on tape and reel specifications, including part orientation and tape sizes, please refer to our Tape and Reel Packaging Specification Brochure, BRD8011/D.

FUNCTIONAL BLOCK DIAGRAM AND PINOUT

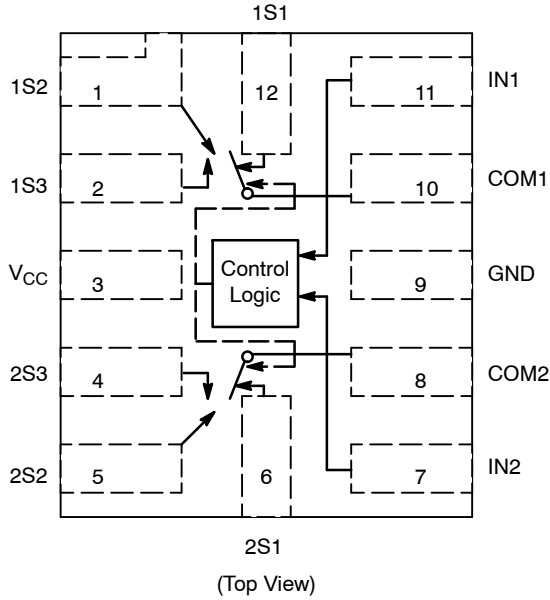

Figure 1. Internal Block Diagram

PIN DESCRIPTIONS

Pin#	Name	Direction	Description
1	1S2	I/O	Switch #1 Position 2 Signal Line
2	1S3	I/O	Switch #1 Position 3 Signal Line
3	V <sub>CC</sub>	Input	Power Supply
4	2S3	I/O	Switch #2 Position 3 Signal Line
5	2S2	I/O	Switch #2 Position 2 Signal Line
6	2S1	I/O	Switch #2 Position 1 Signal Line
7	IN2	Input	Bit 1 Control Input Select Line
8	COM2	I/O	Switch #2 Common Signal Line
9	GND	Input	Ground
10	COM1	I/O	Switch #1 Common Signal Line
11	IN1	Input	Bit 0 Control Input Select Line
12	1S1	I/O	Switch #1 Position 1 Signal Line

FUNCTION TABLE

IN1 [0]	IN2 [1]	COM1 Closed to:	COM2 Closed to:
0	0	No Connect	No Connect
1	0	1S1	2S1
0	1	1S2	2S2
1	1	1S3	2S3

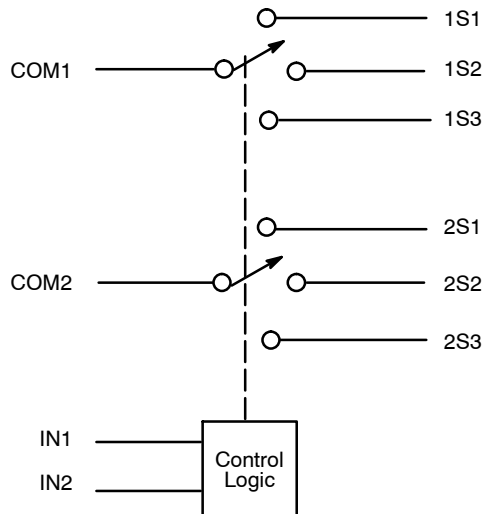

Figure 2. Functional Block Diagram

**OPERATING CONDITIONS**

**MAXIMUM RATINGS**

Symbol	Pins	Parameter	Value	Condition	Unit
V <sub>CC</sub>	V <sub>CC</sub>	Positive DC Supply Voltage	-0.5 to +5.5		V
V <sub>IS</sub>	1Sx, 2Sx	Analog Signal Voltage	-0.5 to V <sub>CC</sub> + 0.3		V
	COMx		-0.5 to 5.3		
V <sub>IN</sub>	IN1, IN2	Control Input Voltage	-0.5 to 4.6		V
I <sub>CC</sub>	V <sub>CC</sub>	Positive DC Supply Current	50		mA
I <sub>IS_CON</sub>	1Sx, 2Sx COMx	Analog Signal Continuous Current	± 300	Closed Switch	mA
I <sub>IS_PK</sub>	1Sx, 2Sx COMx	Analog Signal Peak Current	± 500	10% Duty Cycle	mA
I <sub>IN</sub>	IN1, IN2	Control Input Current	± 20		mA
T <sub>STG</sub>		Storage Temperature Range	-65 to 150		°C

Stresses exceeding Maximum Ratings may damage the device. Maximum Ratings are stress ratings only. Functional operation above the Recommended Operating Conditions is not implied. Extended exposure to stresses above the Recommended Operating Conditions may affect device reliability.

**RECOMMENDED OPERATING CONDITIONS**

Symbol	Pins	Parameter	Value	Condition	Unit
V <sub>CC</sub>	V <sub>CC</sub>	Positive DC Supply Voltage	1.65 to 4.5		V
V <sub>IS</sub>	1Sx, 2Sx	Analog Signal Voltage	GND to V <sub>CC</sub>		V
	COMx		GND to 4.5		
V <sub>IN</sub>	IN1, IN2	Control Input Voltage	GND to V <sub>CC</sub>		V
T <sub>A</sub>		Operating Temperature Range	-40 to 85		°C

Minimum and maximum values are guaranteed through test or design across the **Recommended Operating Conditions**, where applicable. Typical values are listed for guidance only and are based on the particular conditions listed for each section, where applicable. These conditions are valid for all values found in the characteristics tables unless otherwise specified in the test conditions.

**ESD PROTECTION**

Pins	Description	Minimum Voltage
All Pins	Human Body Model	3 kV

DC ELECTRICAL CHARACTERISTICS

CONTROL INPUT (TYPICAL: T = 25°C; V<sub>CC</sub> = 3.3 V)

Symbol	Pins	Parameter	Test Conditions	V <sub>CC</sub>	Min	Typ	Max	Unit
V <sub>IH</sub>	INx	Control Input High	Figure 3	2.7 V 3.3 V 4.2 V	1.25 1.35 1.50			V
V <sub>IL</sub>	INx	Control Input Low	Figure 3	2.7 V 3.3 V 4.2 V			0.4 0.4 0.5	V
I <sub>IN</sub>	INx	Control Input Leakage	V <sub>IS</sub> = GND				± 1.0	μA

SUPPLY CURRENT AND LEAKAGE (TYPICAL: T = 25°C; V<sub>CC</sub> = 3.3 V, V<sub>IN</sub> = V<sub>CC</sub> or GND)

Symbol	Pins	Parameter	Test Conditions	V <sub>CC</sub>	Min	Typ	Max	Unit
I <sub>NO/NC</sub> (OFF)	NC, NO	OFF State Leakage	V <sub>COM</sub> = 3.6 V V <sub>NC</sub> = 1.0 V				± 1.0	μA
I <sub>COM</sub> (ON)	COM	ON State Leakage					± 1.0	μA
I <sub>CC</sub>	V <sub>CC</sub>	Quiescent Supply	V <sub>IS</sub> = V <sub>CC</sub> or GND, I <sub>D</sub> = 0;				1.0	μA
I <sub>OFF</sub>		Power OFF Leakage	V <sub>IS</sub> = GND				1.0	μA

ON RESISTANCE (TYPICAL: T = 25°C; V<sub>CC</sub> = 3.3 V)

Symbol	Pins	Parameter	Test Conditions	V <sub>CC</sub>	Min	Typ	Max	Unit
R <sub>ON</sub>	1Sx, 2Sx COMx	ON Resistance	I <sub>ON</sub> = -8 mA, V <sub>IS</sub> = 0 to V <sub>CC</sub> ;	2.7 V 3.3 V 4.2 V		5 4 3.5	6 5 4.5	Ω
R <sub>FLAT</sub>	1Sx, 2Sx COMx	R <sub>ON</sub> Flatness	I <sub>ON</sub> = -8 mA, V <sub>IS</sub> = 0 to V <sub>CC</sub> ;	2.7 V 3.3 V 4.2 V			1.3 1.4 1.6	Ω
ΔR <sub>ON</sub>	1Sx, 2Sx COMx	R <sub>ON</sub> Matching	I <sub>ON</sub> = -8 mA, V <sub>IS</sub> = 0 to V <sub>CC</sub> ;	2.7 V 3.3 V 4.2 V		0.35		Ω

AC ELECTRICAL CHARACTERISTICS

TIMING/FREQUENCY (TYPICAL: T = 25°C; V<sub>CC</sub> = 3.3 V, R<sub>L</sub> = 50 Ω, C<sub>L</sub> = 5 pF, f = 1 MHz)

Symbol	Pins	Parameter	Test Conditions	Min	Typ	Max	Unit
BW		-3 dB Bandwidth	Power level = 0 dBm		525		MHz
THD		Total Harmonic Distortion	20 Hz to 20 kHz, 1.0 V <sub>PP</sub>		0.01		%
t <sub>ON</sub>	1Sx to 1Sy, 2Sx to 2Sy	Turn On Time			13	30	nS
t <sub>OFF</sub>	1Sy to 1Sx, 2Sy to 2Sx	Turn Off Time			12	25	nS
t <sub>BBM</sub>	1Sx to 1Sy, 2Sx to 2Sy	Break Before Make		2.0			nS

CROSSTALK: (TYPICAL: T = 25°C; V<sub>CC</sub> = 3.3V, R<sub>L</sub> = 50 Ω, C<sub>L</sub> = 35 pF, f = 1MHz)

Symbol	Pins	Parameter	Test Conditions	Min	Typ	Max	Unit
O <sub>IRR</sub>	1Sx or 2Sx	Off Isolation	V <sub>IN</sub> = 0		-60		dB
X <sub>talk</sub>	COMx to COMy	Non-Adjacent Channel			-60		dB

CAPACITANCE (TYPICAL: T = 25°C; V<sub>CC</sub> = 3.3V, R<sub>L</sub> = 50 Ω, C<sub>L</sub> = 5 pF, f = 1 MHz)

Symbol	Pins	Parameter	Test Conditions	Min	Typ	Max	Unit
C <sub>IN</sub>	INx	Control Input	V <sub>CC</sub> = 0 V		3		pF
C <sub>ON</sub>	1Sx or 2Sx to COM	Through Switch	V <sub>CC</sub> = 3.3 V, V <sub>IN</sub> = 0 V		16	20	pF
C <sub>OFF</sub>	1Sx, 2Sx COMx	Unselected Port	V <sub>CC</sub> = V <sub>IN</sub> = 3.3 V		8		pF

# NCN9252

## Detailed Description

The NCN9252 is a DP3T switch designed for applications where a single USB connector is used for multiple data applications within a portable system. Two differential signals from a USB connector can be routed to 3 different end locations. The first, channel 1, is optimized for a high-speed, USB 2.0 transceiver. The second and third, channels 2 and 3, are optimized for UART or remote data applications.

## Control Inputs Select Logic

The NCN9252 is made up of two, triple-throw switches operating off of the same internal enable signal. For each switch, a signal can pass from the common pin to any of three terminals. Whenever COM1 is closed to terminal 1S2, COM2 will respectively be closed to terminal 2S2. The select logic is controlled by two inputs, IN1 and IN2, connecting the common pins to the terminals according to the function table found on page 2. Since there are four possible control states but only 3 possible terminals, the first combination results in an open connection for all three terminals.

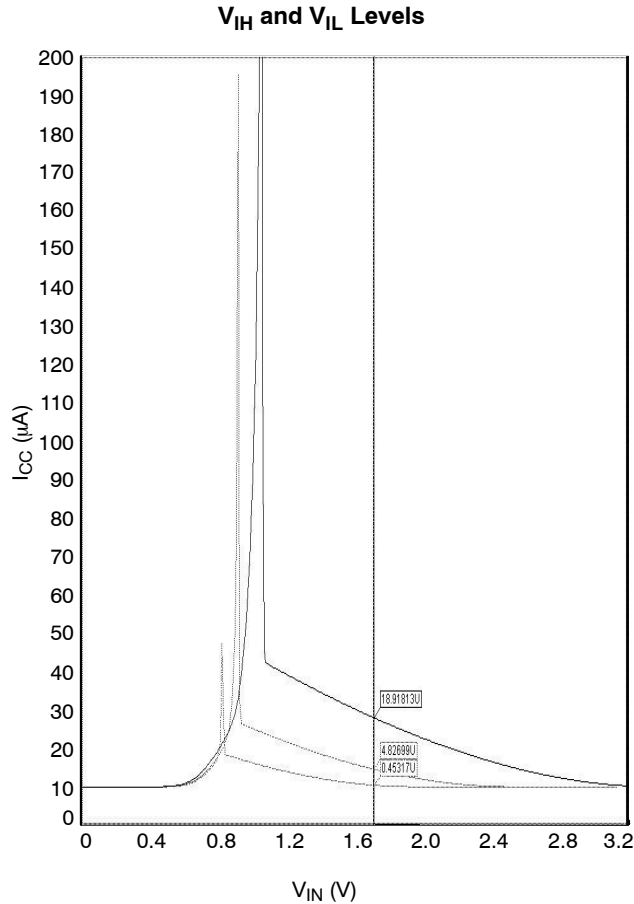

Figure 3. I<sub>CC</sub> Leakage Current vs. V<sub>IN</sub>

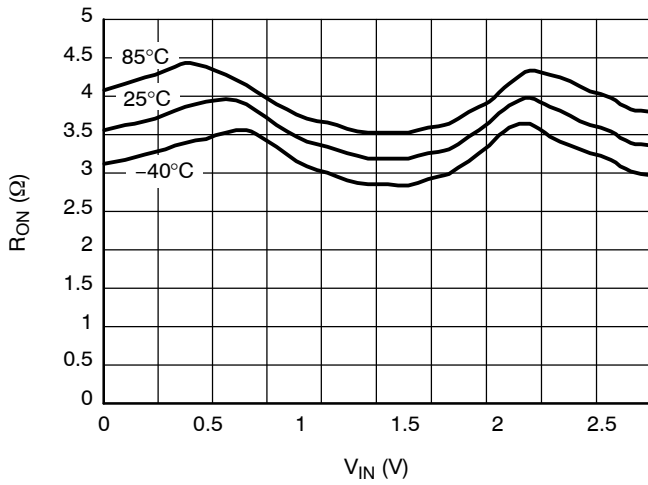

Figure 4. On-Resistance vs. Input Voltage  
@  $V_{CC} = 2.7\text{ V}$

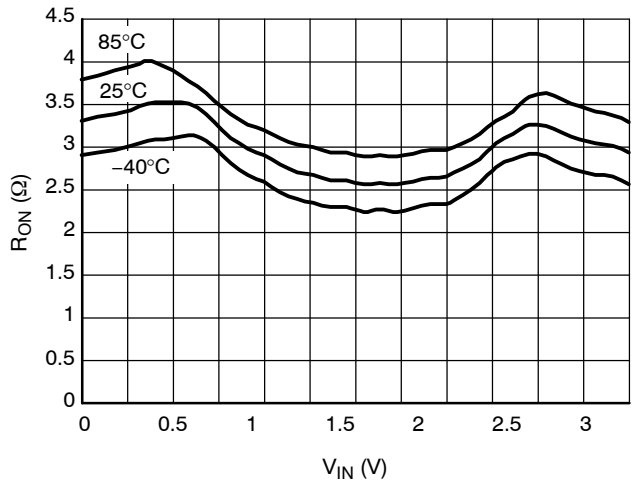

Figure 5. On-Resistance vs. Input Voltage  
@  $V_{CC} = 3.3\text{ V}$

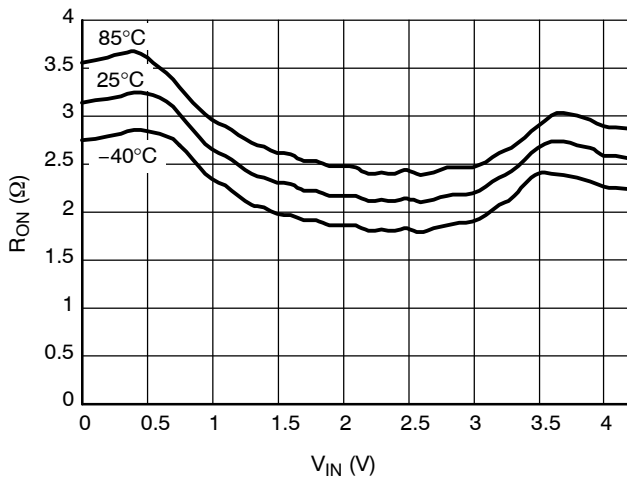

Figure 6. On-Resistance vs. Input Voltage  
@  $V_{CC} = 4.2\text{ V}$

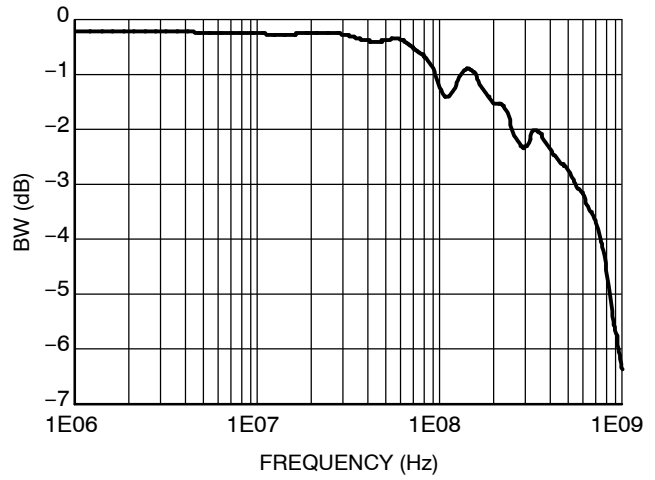

Figure 7. Bandwidth vs. Frequency

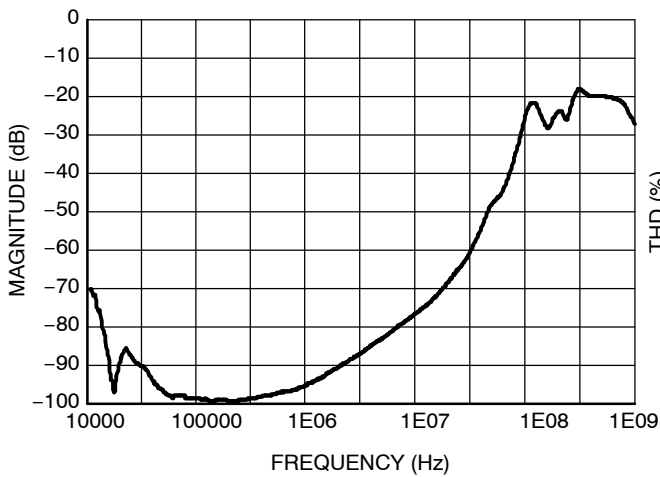

Figure 8. Cross Talk vs. Frequency  
@  $25^\circ\text{C}$

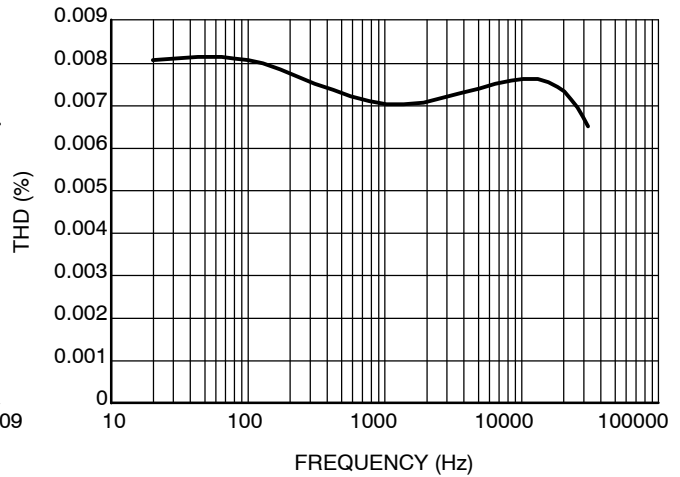

Figure 9. Total Harmonic Distortion vs. Frequency

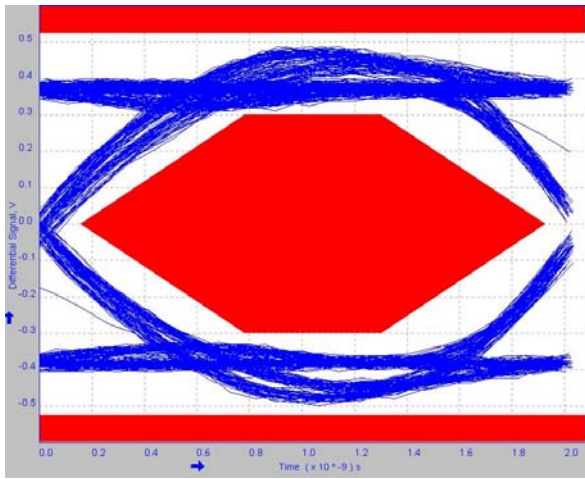

Figure 10. Channel 1S1/2S1 USB2.0 Near End Eye Diagram ( $V_{CC} = 3.3\text{ V}$ ,  $IN1 = 1$ ,  $IN2 = 0$ ,  $Temp = 25^{\circ}\text{C}$ )

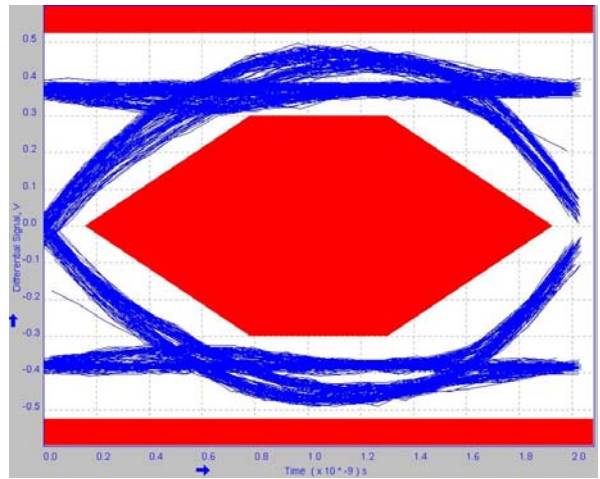

Figure 11. Channel 1S2/2S2 USB2.0 Near End Eye Diagram ( $V_{CC} = 3.3\text{ V}$ ,  $IN1 = 0$ ,  $IN2 = 1$ ,  $Temp = 25^{\circ}\text{C}$ )

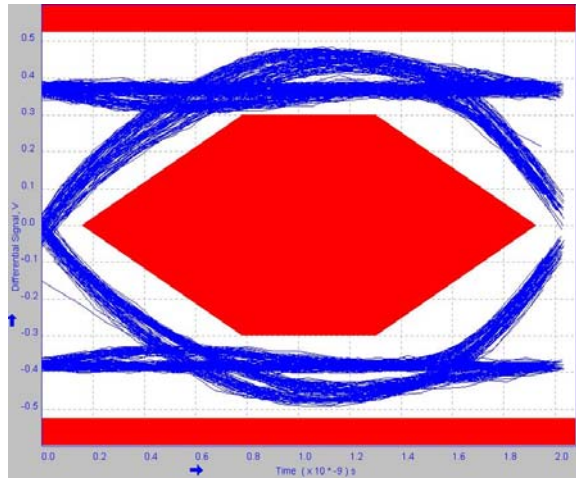

Figure 12. Channel 1S3/2S3 USB2.0 Near End Eye Diagram ( $V_{CC} = 3.3\text{ V}$ ,  $IN1 = 1$ ,  $IN2 = 1$ ,  $Temp = 25^{\circ}\text{C}$ )

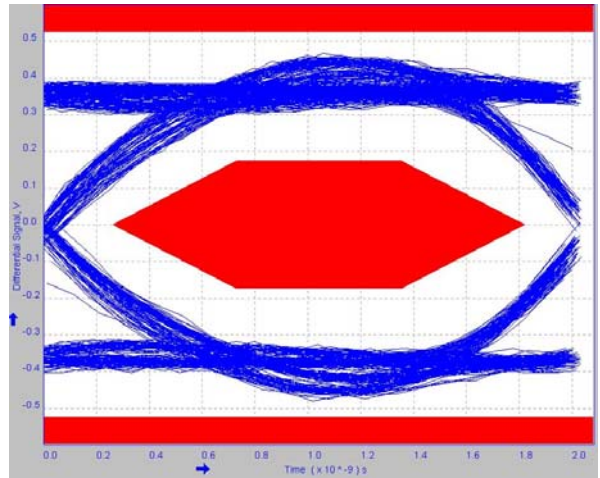

Figure 13. Channel 1S1/2S1 USB2.0 Far End Eye Diagram ( $V_{CC} = 3.3\text{ V}$ ,  $IN1 = 1$ ,  $IN2 = 0$ ,  $Temp = 25^{\circ}\text{C}$ )

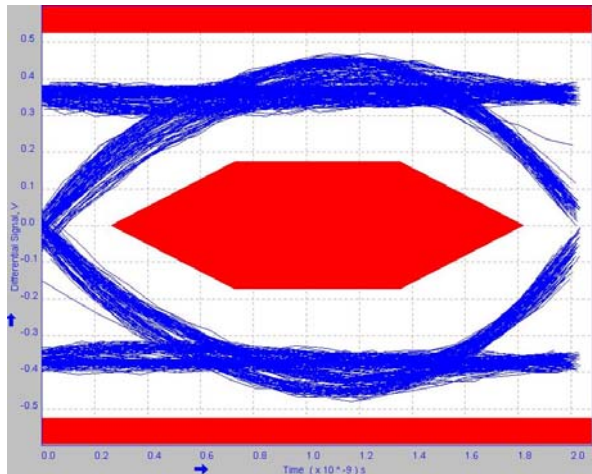

Figure 14. Channel 1S2/2S2 USB2.0 Far End Eye Diagram ( $V_{CC} = 3.3\text{ V}$ ,  $IN1 = 0$ ,  $IN2 = 1$ ,  $Temp = 25^{\circ}\text{C}$ )

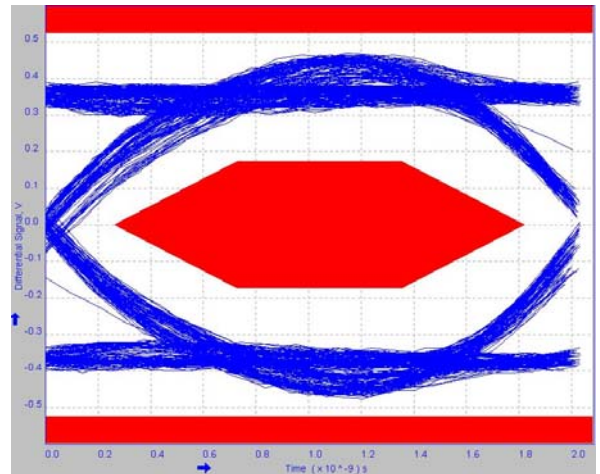

Figure 15. Channel 1S3/2S3 USB2.0 Far End Eye Diagram ( $V_{CC} = 3.3\text{ V}$ ,  $IN1 = 1$ ,  $IN2 = 1$ ,  $Temp = 25^{\circ}\text{C}$ )



# NCN9252

## PACKAGE DIMENSIONS

### UQFN12 1.7x2.0, 0.4P CASE 523AE-01 ISSUE A

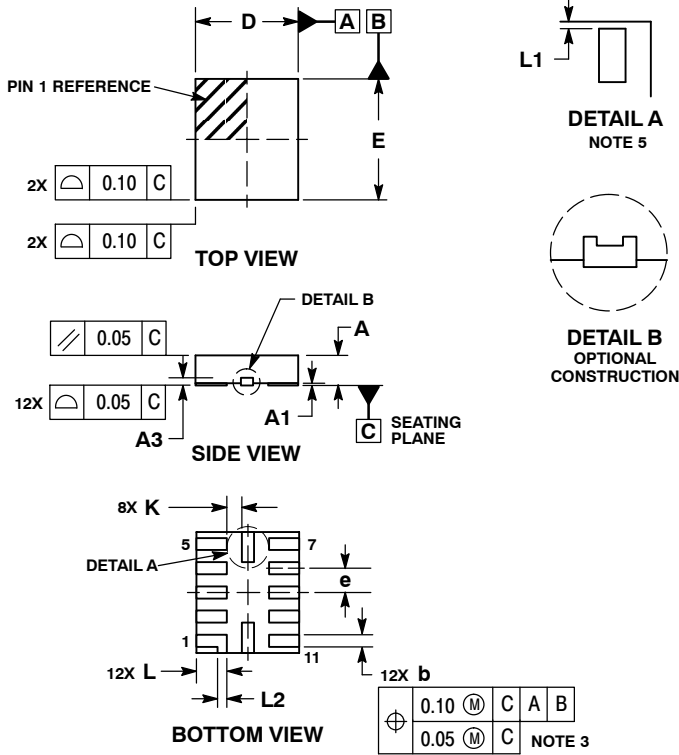

**NOTES:**

1. DIMENSIONING AND TOLERANCING PER ASME Y14.5M, 1994.
2. CONTROLLING DIMENSION: MILLIMETERS
3. DIMENSION b APPLIES TO PLATED TERMINAL AND IS MEASURED BETWEEN 0.15 AND 0.30 MM FROM TERMINAL TIP.
4. MOLD FLASH ALLOWED ON TERMINALS ALONG EDGE OF PACKAGE. FLASH 0.03 MAX ON BOTTOM SURFACE OF TERMINALS.
5. DETAIL A SHOWS OPTIONAL CONSTRUCTION FOR TERMINALS.

DIM	MILLIMETERS	
	MIN	MAX
A	0.45	0.55
A1	0.00	0.05
A3	0.127 REF	
b	0.15	0.25
D	1.70 BSC	
E	2.00 BSC	
e	0.40 BSC	
K	0.20	----
L	0.45	0.55
L1	0.00	0.03
L2	0.15 REF	

### MOUNTING FOOTPRINT SOLDERMASK DEFINED

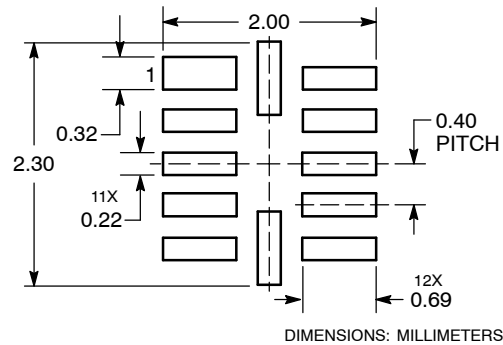

\*For additional information on our Pb-Free strategy and soldering details, please download the ON Semiconductor Soldering and Mounting Techniques Reference Manual, SOLDERRM/D.

ON Semiconductor and are registered trademarks of Semiconductor Components Industries, LLC (SCILLC). SCILLC reserves the right to make changes without further notice to any products herein. SCILLC makes no warranty, representation or guarantee regarding the suitability of its products for any particular purpose, nor does SCILLC assume any liability arising out of the application or use of any product or circuit, and specifically disclaims any and all liability, including without limitation special, consequential or incidental damages. "Typical" parameters which may be provided in SCILLC data sheets and/or specifications can and do vary in different applications and actual performance may vary over time. All operating parameters, including "Typicals" must be validated for each customer application by customer's technical experts. SCILLC does not convey any license under its patent rights nor the rights of others. SCILLC products are not designed, intended, or authorized for use as components in systems intended for surgical implant into the body, or other applications intended to support or sustain life, or for any other application in which the failure of the SCILLC product could create a situation where personal injury or death may occur. Should Buyer purchase or use SCILLC products for any such unintended or unauthorized application, Buyer shall indemnify and hold SCILLC and its officers, employees, subsidiaries, affiliates, and distributors harmless against all claims, costs, damages, and expenses, and reasonable attorney fees arising out of, directly or indirectly, any claim of personal injury or death associated with such unintended or unauthorized use, even if such claim alleges that SCILLC was negligent regarding the design or manufacture of the part. SCILLC is an Equal Opportunity/Affirmative Action Employer. This literature is subject to all applicable copyright laws and is not for resale in any manner.

### PUBLICATION ORDERING INFORMATION

**LITERATURE FULFILLMENT:**  
Literature Distribution Center for ON Semiconductor  
P.O. Box 5163, Denver, Colorado 80217 USA  
Phone: 303-675-2175 or 800-344-3860 Toll Free USA/Canada  
Fax: 303-675-2176 or 800-344-3867 Toll Free USA/Canada  
Email: orderlit@onsemi.com

**N. American Technical Support:** 800-282-9855 Toll Free  
USA/Canada  
**Europe, Middle East and Africa Technical Support:**  
Phone: 421 33 790 2910  
**Japan Customer Focus Center**  
Phone: 81-3-5773-3850

**ON Semiconductor Website:** [www.onsemi.com](http://www.onsemi.com)  
**Order Literature:** <http://www.onsemi.com/orderlit>

For additional information, please contact your local Sales Representative