



SP1820

Four Channels Constant Current LED Driver

DESCRIPTION

The SP1820 is a four channels constant current driver white LED. The device can drive up to 20mA load current per channel from single cell Lithium Ion battery. SP1820 can provide lowest cost LED driver for various applications. It does not require any external components. Internal thermal protection automatically adjusts LED current to prevent overheating.

The dimming control can be achieved by feeding a PWM or analog signal into the Iset pin. The device can be shut down by Enable low.

APPLICATIONS

- Battery Powered Devices
- Digital Camera
- PDA, MP3/4
- GPS
- Mobile Phone
- Keyboard/Display Backlight

FEATURES

- Low Cost LED Driver
- Constant Current Output
- Four Channels LED Driver Provides Matching LED Current
- Low Quiescent Current
- Disconnects LEDs in Shutdown Mode
- Thermal Shut Down Protection
- Current Adjustable via external resistor
- Dimming Control thru either Enable or Iset

PIN CONFIGURATION(SOP – 8P)

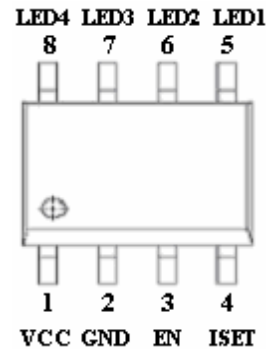

PART MARKING

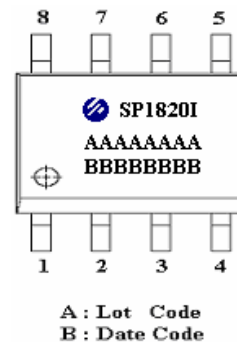



SP1820

Four Channels Constant Current LED Driver

TYPICAL APPLICATION CIRCUIT

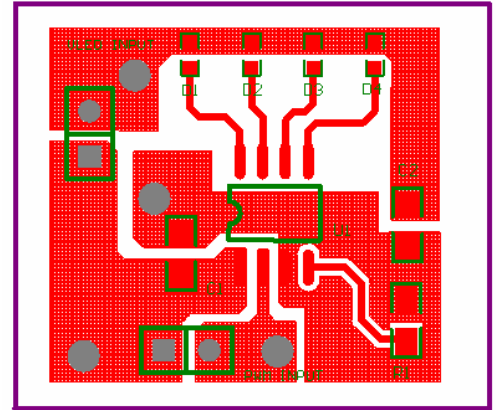
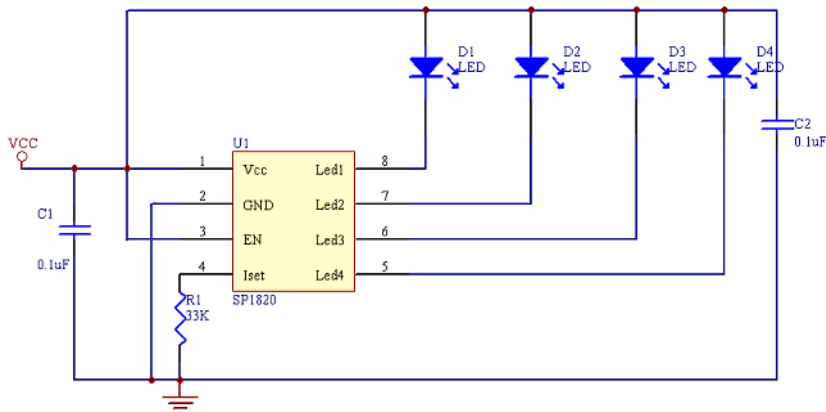

PIN DESCRIPTION

Pin	Symbol	Description
1	VCC	Supply Voltage Input
2	GND	Ground
3	EN	High Enable Pin
4	ISET	Current Set Input
5	LED1	LED 1
6	LED2	LED 2
7	LED3	LED 3
8	LED4	LED 4

ORDERING INFORMATION

Part Number	Package	Part Marking
SP1820S8RGB	SOP- 8P	SP1820

※ SP1820S8RGB : 13" Tape Reel ; Pb – Free ; Halogen – Free



SP1820

Four Channels Constant Current LED Driver

BLOCK DIAGRAM

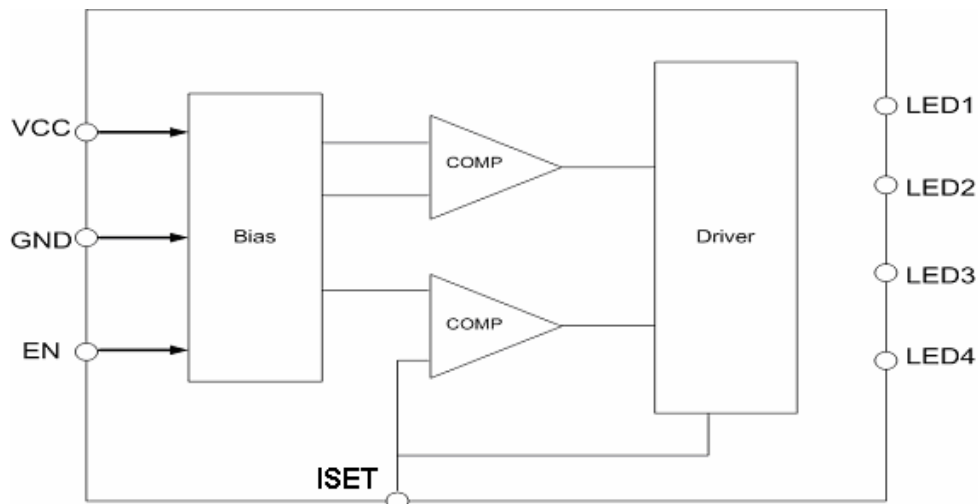

ABSOLUTE MAXIMUM RATINGS

($T_A=25^{\circ}\text{C}$ Unless otherwise specified)

Parameter	Symbol	Value	Unit
DC Supply Voltage	V_{IN}	5.5	V
Output LED Current	I_{LED}	20	mA
Operating Temperature	T_{OPR}	-40 ~ 85	$^{\circ}\text{C}$
Maximum Junction Temperature	$T_{J(Max)}$	125	$^{\circ}\text{C}$
Storage Temperature	T_S	-65 ~ 150	$^{\circ}\text{C}$

The IC has a protection circuit against static electricity. Do not apply high static electricity or high voltage that exceeds the performance of the protection circuit to the IC.

ELECTRICAL CHARACTERISTICS

($T_A=25^{\circ}\text{C}$, $V_{IN}=3.6\text{V}$, $R_{SET}=7.5\text{K}\Omega$, $V_{LED}=0.5\text{V}$, Unless otherwise specified)

Parameter	Conditions	Min.	Typ.	Max.	Unit
Operating Voltage		2.7		5.5	V
LED Current		18.5	20	21.5	mA
Current Matching CH to CH			+/-1.5	+/-3.5	%
Quiescent Current	$I_{LED} = 0\text{A}$, $R_{set} = \text{Open}$		250		μA
Line Regulation	I_{LED} Change Per Volt V_{cc} Change		0.15	0.6	%/V
Load Regulation	$V_{LED} < 5\text{V}$, $I_{LED} = 20\text{mA}$		3	6	%/V
ISET Voltage			1.5		V
Enable Voltage High	$3.6\text{V} \leq V_{in} \leq 4.2\text{V}$	3.6			V
Enable Voltage Low	$3.6\text{V} \leq V_{in} \leq 4.2\text{V}$			0.4	V
Thermal Shutdown Threshold			130		$^{\circ}\text{C}$
Thermal Shutdown Hysteresis			20		$^{\circ}\text{C}$
Current Off Mode			0.2		μA



SP1820

Four Channels Constant Current LED Driver

PERFORMANCE CHARACTERISTICS ($T_A=25^\circ\text{C}$, unless otherwise specified.)

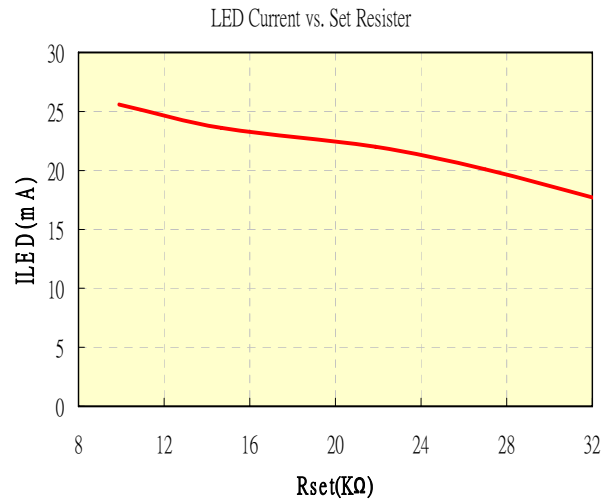
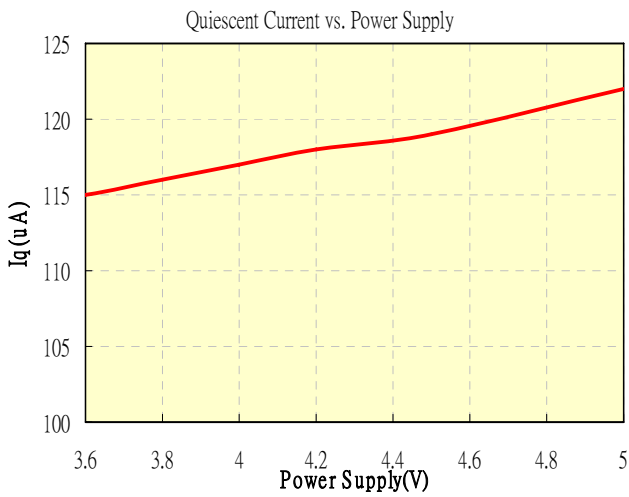
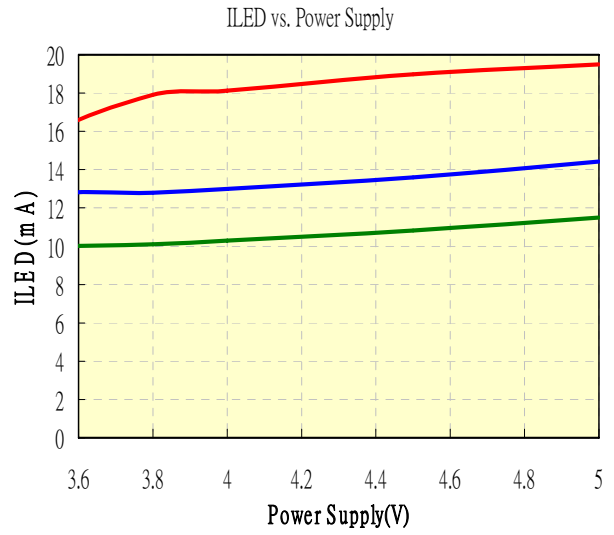
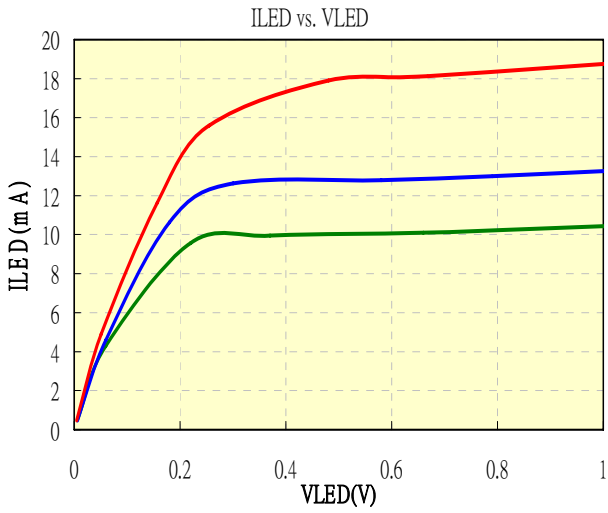



SP1820

Four Channels Constant Current LED Driver

APPLICATION INFORMATION

CIRCUIT DESCRIPTION

SP1820 is a four channels white-LED driver with matching current output. The matching current regulator has a 460:1 ratio between ILED and ISET. SP1820 is capable to supply 25mA for each channel with proper selection of external resistor. The design has a band gap regulator, voltage to current converter and mirror drivers.

THERMAL PROTECTION

SP1820 has a thermal comparator to shut down the device when the internal temperature reaches 150°C. It will remain shut down until the temperature drops to 130°C.

ENABLE

SP1820 has an enable pin that is designed for TTL input. The device will be active at voltage high. This pin can also be used to control the brightness of LED with a PWM signal. The brightness is proportional to the duty cycle of the PWM signal. When duty cycle is zero, LEDs are turned off. For 50% duty cycle, it will result an average ILED to be half the programmed LED current which is set by RSET.

ISET

The ISET Pin is a voltage input to set the current of LED. An external resistor is used to set the output current, as approximated with the following equation:

$$RSET = 460 * (1.2V/I_{LED})$$

However, the RSET shall not be selected to exceed the maximum current delivery capability of the device, 25mA. A PWM signal or analog signal can also be applied at ISET pin to control the LED brightness.



SP1820

Four Channels Constant Current LED Driver

SOP- 8 PACKAGE OUTLINE

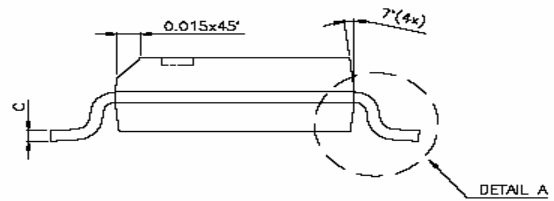
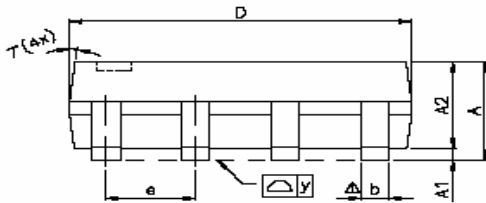
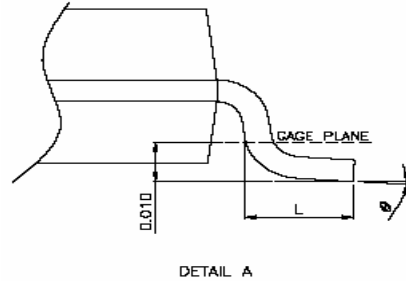
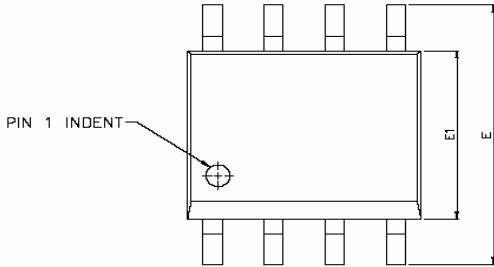

SYMBOLS	DIMENSIONS IN MILLIMETERS			DIMENSIONS IN INCHES		
	MIN	NOM	MAX	MIN	NOM	MAX
A	1.47	1.60	1.73	0.058	0.063	0.068
A1	0.10	—	0.25	0.004	—	0.010
A2	—	1.45	—	—	0.057	—
b	0.33	0.41	0.51	0.013	0.016	0.020
C	0.19	0.20	0.25	0.0075	0.008	0.0098
D	4.80	4.85	4.95	0.189	0.191	0.195
E	5.80	6.00	6.20	0.228	0.236	0.244
E1	3.80	3.90	4.00	0.150	0.154	0.157
e	—	1.27	—	—	0.050	—
L	0.38	0.71	1.27	0.015	0.028	0.050
Δ y	—	—	0.076	—	—	0.003
θ	0°	—	8°	0°	—	8°



SP1820

Four Channels Constant Current LED Driver

Information provided is alleged to be exact and consistent. SYNC Power Corporation presumes no responsibility for the penalties of use of such information or for any violation of patents or other rights of third parties which may result from its use. No license is granted by allegation or otherwise under any patent or patent rights of SYNC Power Corporation. Conditions mentioned in this publication are subject to change without notice. This publication surpasses and replaces all information previously supplied. SYNC Power Corporation products are not authorized for use as critical components in life support devices or systems without express written approval of SYNC Power Corporation.

©The SYNC Power logo is a registered trademark of SYNC Power Corporation

©2004 SYNC Power Corporation – Printed in Taiwan – All Rights Reserved

SYNC Power Corporation

7F-2, No.3-1, Park Street

NanKang District (NKSP), Taipei, Taiwan 115

Phone: 886-2-2655-8178

Fax: 886-2-2655-8468

<http://www.syncpower.com>
