

**NOT RECOMMENDED FOR NEW DESIGNS
POSSIBLE SUBSTITUTE PRODUCT
ISL22416, ISL22419**

**Single Digitally Controlled (XDCP™)
Potentiometer**

FEATURES

- Single Voltage Potentiometer
- 64 Resistor Taps
- SPI Serial Interface for Write, Read, and Transfer Operations of the Potentiometer
- Wiper Resistance, 150Ω Typical at 5V
- 4 Non-Volatile Data Registers
- Non-Volatile Storage of Multiple Wiper Positions
- Power-on Recall. Loads Saved Wiper Position on Power-up.
- Standby Current < 5μA Max
- V_{CC} : 2.7V to 5.5V Operation
- 2.5kΩ, 10kΩ End to End Resistance
- 100 yr. Data Retention
- Endurance: 100, 000 Data Changes per Bit per Register
- 14 Ld TSSOP, 16 Ld SOIC
- Low Power CMOS
- Pb-Free Plus Anneal Available (RoHS Compliant)

DESCRIPTION

The X9421 integrates a single digitally controlled potentiometer (XDCP) on a monolithic CMOS integrated circuit.

The digital controlled potentiometer is implemented using 63 resistive elements in a series array. Between each element are tap points connected to the wiper terminal through switches. The position of the wiper on the array is controlled by the user through the SPI bus interface. The potentiometer has associated with it a volatile Wiper Counter Register (WCR) and a four non-volatile Data Registers that can be directly written to and read by the user. The contents of the WCR controls the position of the wiper on the resistor array through the switches. Powerup recalls the contents of the default data register (DRO) to the WCR.

The XDCP can be used as a three-terminal potentiometer or as a two terminal variable resistor in a wide variety of applications including control, parameter adjustments, and signal processing.

BLOCK DIAGRAM

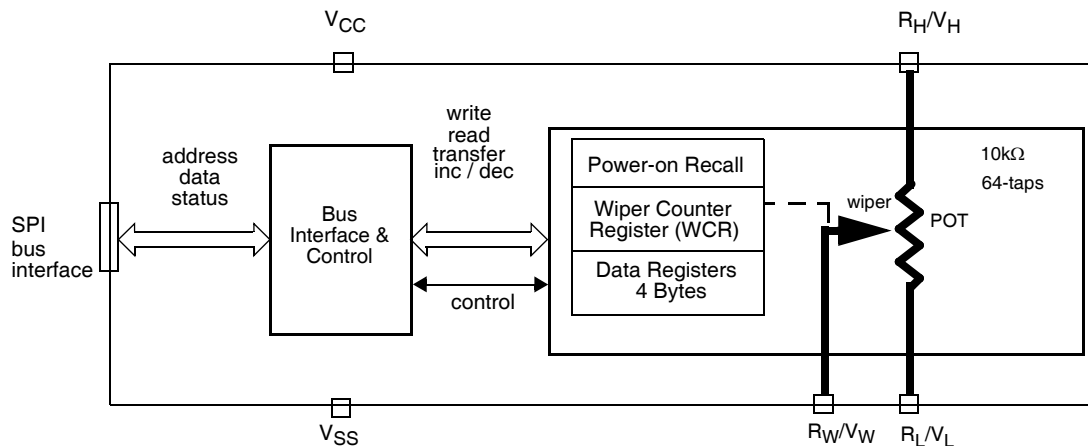

Ordering Information

PART NUMBER	PART MARKING	V _{CC} LIMITS (V)	POTENTIOMETER ORGANIZATION (k Ω)	TEMP RANGE (°C)	PACKAGE	
X9421YS16*	X9421YS	5 \pm 10%	2.5	0 to 70	16 Ld SOIC (300 mil)	
X9421YS16Z* (Note)	X9421YS Z			0 to 70	16 Ld SOIC (300 mil) (Pb-free)	
X9421YS16I*	X9421YS I			-40 to 85	16 Ld SOIC (300 mil)	
X9421YS16IZ* (Note)	X9421YS ZI			-40 to 85	16 Ld SOIC (300 mil) (Pb-free)	
X9421YV14*	X9421YV			0 to 70	14 Ld TSSOP (4.4mm)	
X9421YV14Z* (Note)	X9421YV Z			0 to 70	14 Ld TSSOP (4.4mm) (Pb-free)	
X9421YV14I*	X9421YV I			-40 to 85	14 Ld TSSOP (4.4mm)	
X9421YV14IZ* (Note)	X9421YV ZI			-40 to 85	14 Ld TSSOP (4.4mm) (Pb-free)	
X9421WS16*	X9421WS		2.5	10	0 to 70	16 Ld SOIC (300 mil)
X9421WS16Z* (Note)	X9421WS Z				0 to 70	16 Ld SOIC (300 mil) (Pb-free)
X9421WS16I*	X9421WS I				-40 to 85	16 Ld SOIC (300 mil)
X9421WS16IZ* (Note)	X9421WS ZI				-40 to 85	16 Ld SOIC (300 mil) (Pb-free)
X9421WV14*	X9421WV				0 to 70	14 Ld TSSOP (4.4mm)
X9421WV14Z* (Note)	X9421WV Z				0 to 70	14 Ld TSSOP (4.4mm) (Pb-free)
X9421WV14I*	X9421WV I				-40 to 85	14 Ld TSSOP (4.4mm)
X9421WV14IZ* (Note)	X9421WV ZI				-40 to 85	14 Ld TSSOP (4.4mm) (Pb-free)
X9421YS16-2.7*	X9421YS F	2.7 to 5.5	2.5	0 to 70	16 Ld SOIC (300 mil)	
X9421YS16Z-2.7* (Note)	X9421YS ZF			0 to 70	16 Ld SOIC (300 mil) (Pb-free)	
X9421YS16I-2.7*	X9421YS G			-40 to 85	16 Ld SOIC (300 mil)	
X9421YS16IZ-2.7* (Note)	X9421YS ZG			-40 to 85	16 Ld SOIC (300 mil) (Pb-free)	
X9421YV14-2.7*	X9421YV F			0 to 70	14 Ld TSSOP (4.4mm)	
X9421YV14Z-2.7* (Pb-free)	X9421YV ZF			0 to 70	14 Ld TSSOP (4.4mm) (Pb-free)	
X9421YV14I-2.7*	X9421YV G			-40 to 85	14 Ld TSSOP (4.4mm)	
X9421YV14IZ-2.7* (Pb-free)	X9421YV ZG			-40 to 85	14 Ld TSSOP (4.4mm) (Pb-free)	
X9421WS16-2.7*	X9421WS F		2.5	10	0 to 70	16 Ld SOIC (300 mil)
X9421WS16Z-2.7* (Note)	X9421WS ZF				0 to 70	16 Ld SOIC (300 mil) (Pb-free)
X9421WS16I-2.7*	X9421WS G				-40 to 85	16 Ld SOIC (300 mil)
X9421WS16IZ-2.7* (Note)	X9421WS ZG				-40 to 85	16 Ld SOIC (300 mil) (Pb-free)
X9421WV14-2.7*	X9421WV F				0 to 70	14 Ld TSSOP (4.4mm)
X9421WV14Z-2.7* (Pb-free)	X9421WV ZF				0 to 70	14 Ld TSSOP (4.4mm) (Pb-free)
X9421WV14I-2.7*	X9421WV G				-40 to 85	14 Ld TSSOP (4.4mm)
X9421WV14IZ-2.7* (Pb-free)	X9421WV ZG				-40 to 85	14 Ld TSSOP (4.4mm) (Pb-free)

*Add "T1" suffix for tape and reel.

NOTE: Intersil Pb-free plus anneal products employ special Pb-free material sets; molding compounds/die attach materials and 100% matte tin plate termination finish, which are RoHS compliant and compatible with both SnPb and Pb-free soldering operations. Intersil Pb-free products are MSL classified at Pb-free peak reflow temperatures that meet or exceed the Pb-free requirements of IPC/JEDEC J STD-020.

DETAILED FUNCTIONAL DIAGRAM

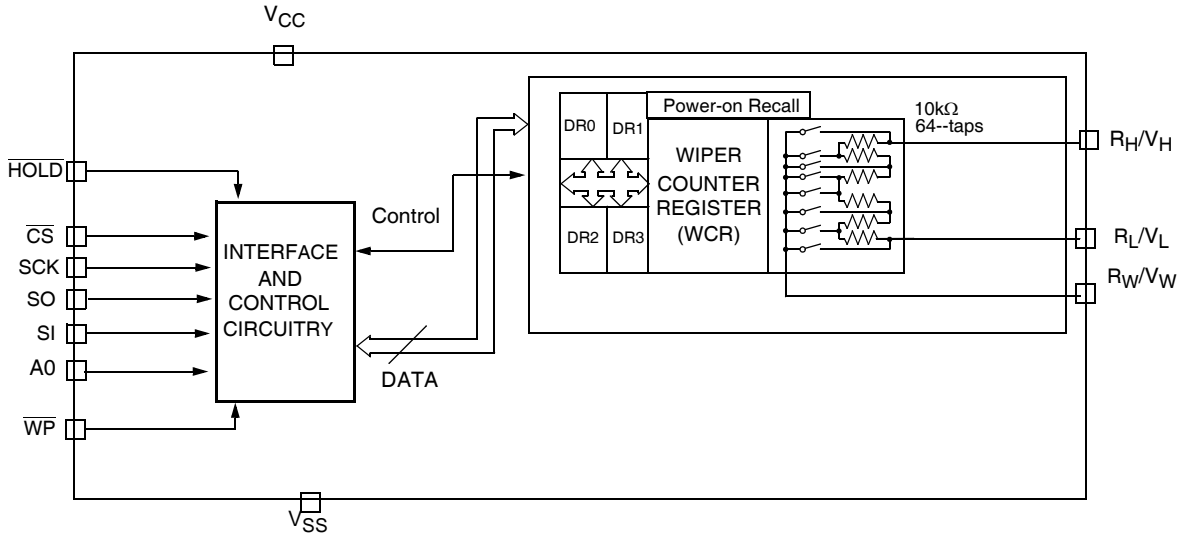

CIRCUIT LEVEL APPLICATIONS

- Vary the gain of a voltage amplifier
- Provide programmable dc reference voltages for comparators and detectors
- Control the volume in audio circuits
- Trim out the offset voltage error in a voltage amplifier circuit
- Set the output voltage of a voltage regulator
- Trim the resistance in Wheatstone bridge circuits
- Control the gain, characteristic frequency and Q-factor in filter circuits
- Set the scale factor and zero point in sensor signal conditioning circuits
- Vary the frequency and duty cycle of timer ICs
- Vary the dc biasing of a pin diode attenuator in RF circuits
- Provide a control variable (I, V, or R) in feedback circuits

SYSTEM LEVEL APPLICATIONS

- Adjust the contrast in LCD displays
- Control the power level of LED transmitters in communication systems
- Set and regulate the DC biasing point in an RF power amplifier in wireless systems
- Control the gain in audio and home entertainment systems
- Provide the variable DC bias for tuners in RF wireless systems
- Set the operating points in temperature control systems
- Control the operating point for sensors in industrial systems
- Trim offset and gain errors in artificial intelligent systems

PIN CONFIGURATION

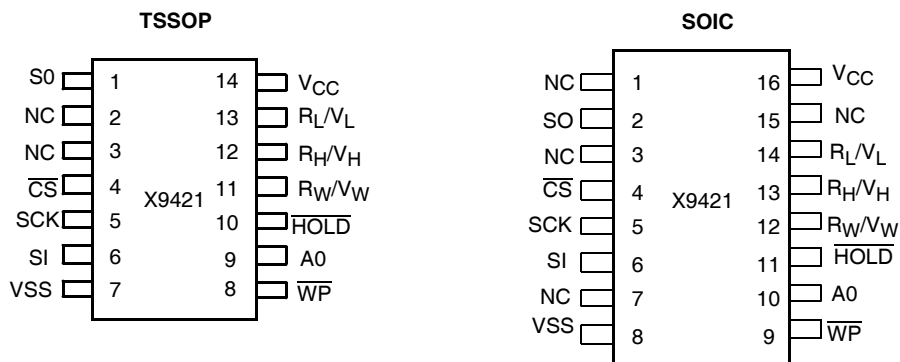

PIN ASSIGNMENTS

TSSOP pin	SOIC pin	Symbol	Brief Description
1	2	SO	Serial Data Output
2	3	NC	No Connect
3		NC	No Connect
4	4	\overline{CS}	Chip Select
5	5	SCK	Serial Clock
6	6	SI	Serial Data Input
7	8	V _{SS}	System Ground
8	9	\overline{WP}	Hardware Write Protect
9	10	A0	Device Address
10	11	\overline{HOLD}	Device select. Pause the serial bus.
11	12	R _W / V _W	Wiper Terminal of the Potentiometer.
12	13	R _H / V _H	High Terminal of the Potentiometer.
13	14	R _L / V _L	Low Terminal of the Potentiometer.
14	16	V _{CC}	System Supply Voltage
	1	NC	No Connect
	7	NC	No Connect
	15	NC	No Connect

PIN DESCRIPTIONS

Host Interface Pins

Serial Output (SO)

SO is a push/pull serial data output pin. During a read cycle, data is shifted out on this pin. Data is clocked out by the falling edge of the serial clock.

Serial Input

SI is the serial data input pin. All opcodes, byte addresses and data to be written to the potentiometer and pot register are input on this pin. Data is latched by the rising edge of the serial clock.

Serial Clock (SCK)

The SCK input is used to clock data into and out of the X9421.

Chip Select (\overline{CS})

When \overline{CS} is HIGH, the X9421 is deselected and the SO pin is at high impedance, and (unless an internal write cycle is underway) the device will be in the standby state. \overline{CS} LOW enables the X9421, placing it in the active power mode. It should be noted that after a power-up, a HIGH to LOW transition on \overline{CS} is required prior to the start of any operation.

Hold (\overline{HOLD})

\overline{HOLD} is used in conjunction with the \overline{CS} pin to select the device. Once the part is selected and a serial sequence is underway, \overline{HOLD} may be used to pause the serial communication with the controller without resetting the serial sequence. To pause, \overline{HOLD} must be brought LOW while SCK is LOW. To resume communication, \overline{HOLD} is brought HIGH, again while SCK is LOW. If the pause feature is not used, \overline{HOLD} should be held HIGH at all times.

Device Address (A_0)

The address input is used to set the least significant bit of the 8-bit slave address. A match in the slave address serial data stream must be made with the address input in order to initiate communication with the X9421. A maximum of 2 devices may occupy the SPI serial bus.

Potentiometer Pins

V_H/R_H , V_L/R_L

The V_H/R_H and V_L/R_L inputs are equivalent to the terminal connections on either end of a mechanical potentiometer.

V_W/R_W

The wiper output is equivalent to the wiper output of a mechanical potentiometer.

Hardware Write Protect Input (\overline{WP})

The \overline{WP} pin when LOW prevents nonvolatile writes to the Data Registers. Writing to the Wiper Counter Register is not restricted.

System/Digital Supply (V_{CC})

V_{CC} is the supply voltage for the system/digital section. V_{SS} is the system ground.

PRINCIPLES OF OPERATION

The X9421 is a highly integrated microcircuit incorporating a resistor array and associated registers and counter and the serial interface logic providing direct communication between the host and the XDCP potentiometer.

Serial Interface

The X9421 supports the SPI interface hardware conventions. The device is accessed via the SI input with data clocked in on the rising SCK. \overline{CS} must be LOW and the \overline{HOLD} and \overline{WP} pins must be HIGH during the entire operation.

The SO and SI pins can be connected together, since they have three state outputs. This can help to reduce system pin count.

Array Description

The X9421 is comprised of one resistor array containing 63 discrete resistive segments that are connected in series. The physical ends of each array are equivalent to the fixed terminals of a mechanical potentiometer (V_H/R_H and V_L/R_L inputs).

At both ends of the array and between each resistor segment is a CMOS switch connected to the wiper (V_W/R_W) output. Within the individual array only one switch may be turned on at a time.

These switches are controlled by a Wiper Counter Register (WCR). The six bits of the WCR are decoded to select, and enable, one of sixty-four switches. The block diagram of the potentiometer is shown in Figure 1.

Wiper Counter Register (WCR)

The X9421 contains a Wiper Counter Register. The WCR can be envisioned as a 6-bit parallel and serial load counter with its outputs decoded to select one of sixty-four switches along its resistor array. The contents of the WCR can be altered in four ways: it may be written directly by the host via the Write Wiper Counter Register instruction (serial load); it may be written indirectly by transferring the contents of one of four associated Data Registers via the XFR Data Register instruction (parallel load); it can be modified one step at a time by the Increment/ Decrement instruction. Finally, it is loaded with the contents of its data register zero (DR0) upon power-up.

The Wiper Counter Register is a volatile register; that is, its contents are lost when the X9421 is powered-down. Although the register is automatically loaded with the value in DR0 upon power-up, this may be different from the value present at power-down.

Data Registers

The potentiometer has four 6-bit nonvolatile Data Registers. These can be read or written directly by the host. Data can also be transferred between any of the four Data Registers and the WCR. It should be noted all operations changing data in one of the Data Registers is a nonvolatile operation and will take a maximum of 10ms.

If the application does not require storage of multiple settings for the potentiometer, the Data Registers can be used as regular memory locations for system parameters or user preference data.

Register Descriptions

Table 1. Data Registers, (6-bit), Nonvolatile

0	0	D5	D4	D3	D2	D1	D0
(MSB)							(LSB)

There are four 6-bit Data Registers associated with the potentiometer.

- {D5~D0}: These bits are for general purpose Non-volatile data storage or for storage of up to four different wiper values.

Table 2. Wiper Counter Register, (6-bit), Volatile

0	0	WP5	WP4	WP3	WP2	WP1	WP0
(MSB)							(LSB)

- {WP5~WP0}: These bits specify the wiper position of the potentiometer.

Figure 1. Detailed Potentiometer Block Diagram

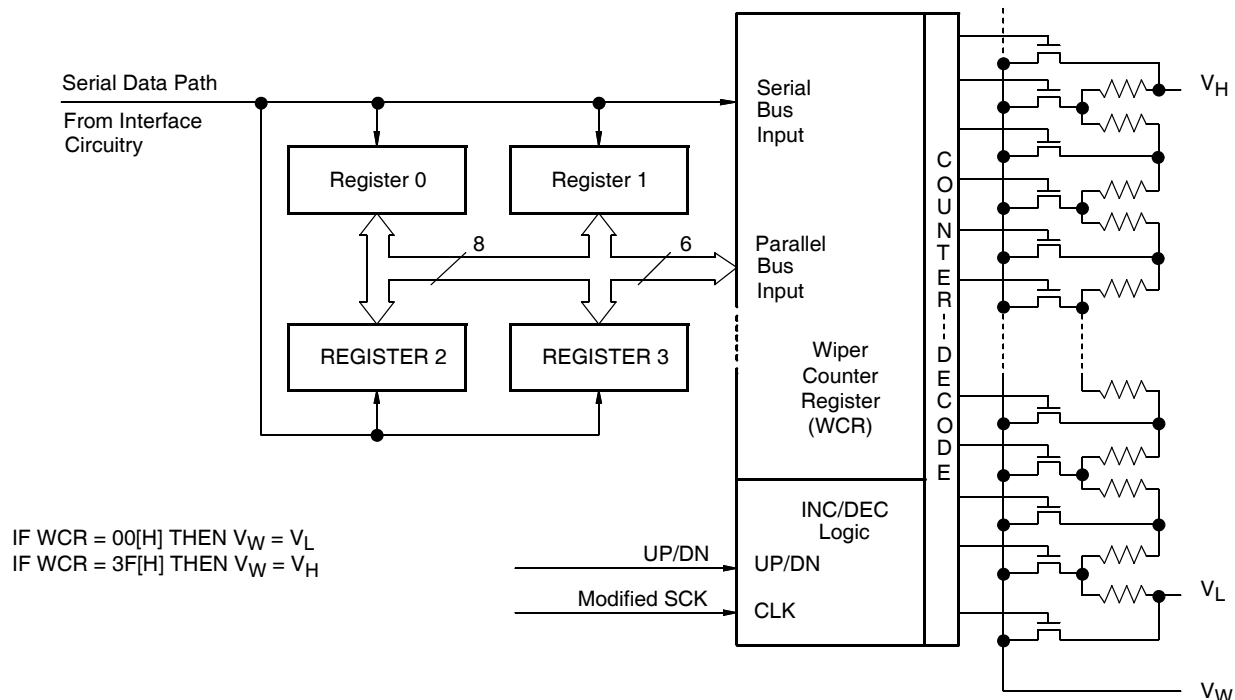

Write in Process

The contents of the Data Registers are saved to nonvolatile memory when the \overline{CS} pin goes from LOW to HIGH after a complete write sequence is received by the device. The progress of this internal write operation can be monitored by a Write In Process bit (WIP). The WIP bit is read with a Read Status command.

INSTRUCTIONS

Address/Identification (ID) Byte

The first byte sent to the X9421 from the host, following a \overline{CS} going HIGH to LOW, is called the Address or Identification byte. The most significant four bits of the slave address are a device type identifier, for the X9421 this is fixed as 0101[B] (refer to Figure 2).

The least significant bit in the ID byte selects one of two devices on the bus. The physical device address is defined by the state of the A_0 input pin. The X9421 compares the serial data stream with the address input state; a successful compare of the address bit is required for the X9421 to successfully continue the command sequence. The A_0 input can be actively driven by a CMOS input signal or tied to V_{CC} or V_{SS} .

The remaining three bits in the ID byte must be set to 110.

Figure 2. Address/Identification Byte Format

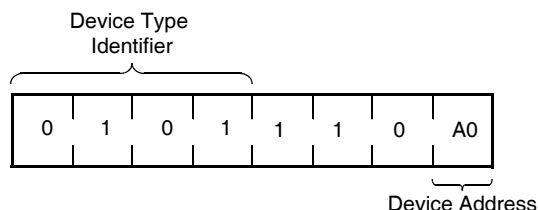

Instruction Byte

The next byte sent to the X9421 contains the instruction and register pointer information. The four most significant bits are the instruction. The next two bits point to one of four Data Registers. The format is shown below in Figure 3.

Figure 3. Instruction Byte Format

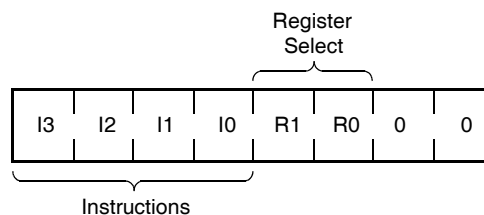

The four high order bits of the instruction byte specify the operation. The next two bits (R_1 and R_0) select one of the four registers that is to be acted upon when a register oriented instruction is issued. The last two bits are defined as 0.

Two of the eight instructions are two bytes in length and end with the transmission of the instruction byte. These instructions are:

- XFR Data Register to Wiper Counter Register — This instruction transfers the contents of one specified Data Register to the Wiper Counter Register.
- XFR Wiper Counter Register to Data Register—This instruction transfers the contents of the Wiper Counter Register to the specified associated Data Register.

The basic sequence of the two byte instructions is illustrated in Figure 4. These two-byte instructions exchange data between the WCR and one of the Data Registers. A transfer from a Data Register to a WCR is essentially a write to a static RAM, with the static RAM controlling the wiper position. The response of the wiper to this action will be delayed by t_{WRL} . A transfer from the WCR (current wiper position), to a Data Register is a write to nonvolatile memory and takes a minimum of t_{WR} to complete. The transfer can occur between the potentiometer and one of its associated registers.

Five instructions require a three-byte sequence to complete. These instructions transfer data between the host and the X9421; either between the host and one of the Data Registers or directly between the host and the WCR. These instructions are:

- Read Wiper Counter Register—read the current wiper position of the pot,
- Write Wiper Counter Register—change current wiper position of the pot,
- Read Data Register—read the contents of the selected data register;
- Write Data Register—write a new value to the selected data register.
- Read Status—This command returns the contents of the WIP bit which indicates if the internal write cycle is in progress.

The sequence of these operations is shown in Figure 5 and Figure 6.

The final command is Increment/Decrement. It is different from the other commands, because it's length is indeterminate. Once the command is issued, the master can clock the wiper up and/or down in one resistor segment steps; thereby, providing a fine tuning capability to the host. For each SCK clock pulse (t_{HIGH}) while SI is HIGH, the selected wiper will move one resistor segment towards the V_H/R_H terminal. Similarly, for each SCK clock pulse while SI is LOW, the selected wiper will move one resistor segment towards the V_L/R_L terminal. A detailed illustration of the sequence and timing for this operation are shown in Figure 7 and Figure 8.

Figure 4. Two-Byte Instruction Sequence

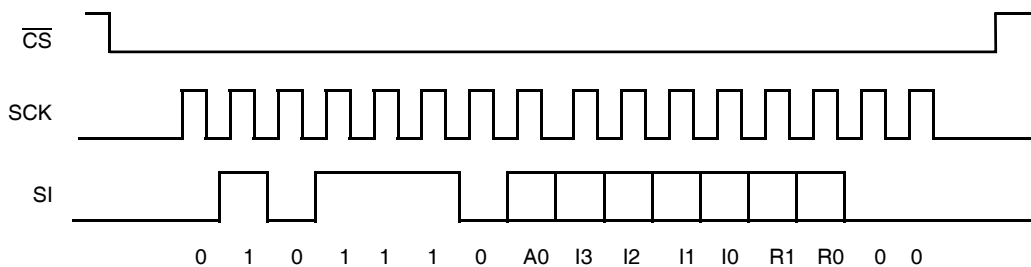

Figure 5. Three-Byte Instruction Sequence (Write)

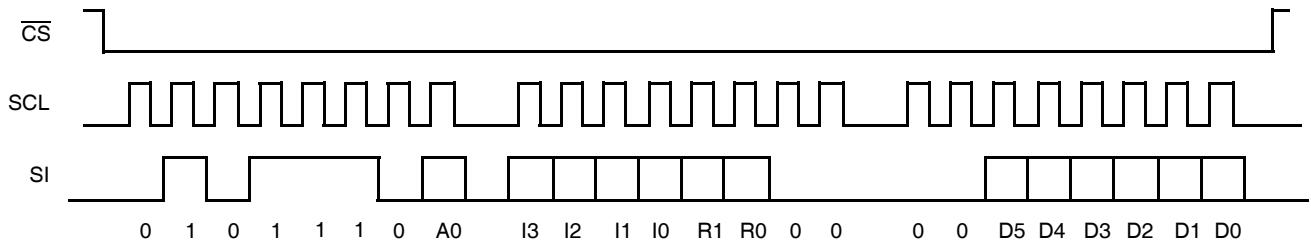

Figure 6. Three-Byte Instruction Sequence (Read)

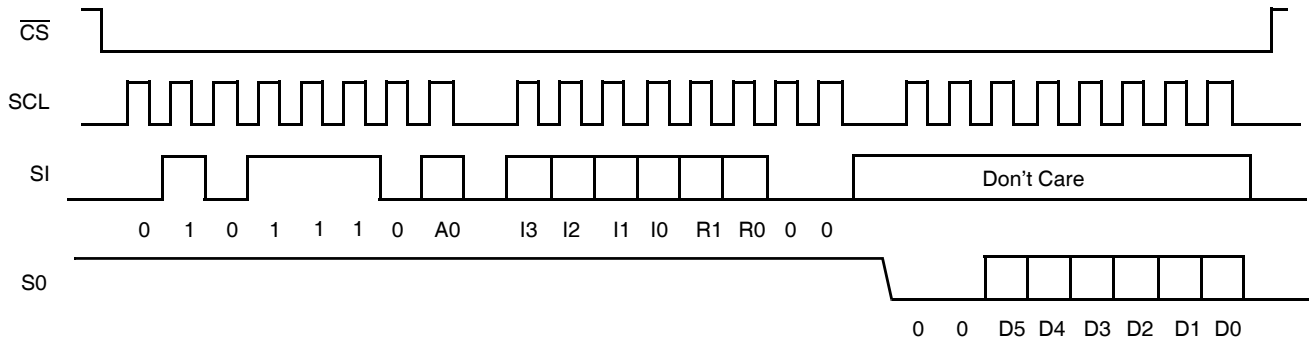

Figure 7. Increment/Decrement Instruction Sequence

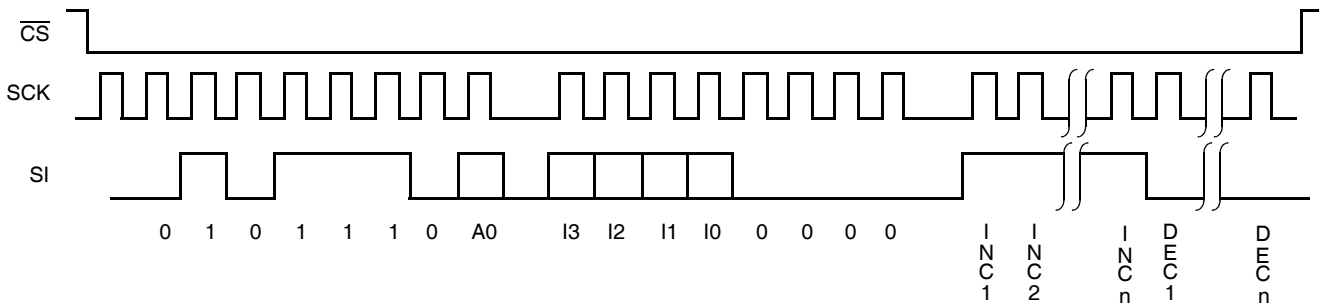

Figure 8. Increment/Decrement Timing Limits

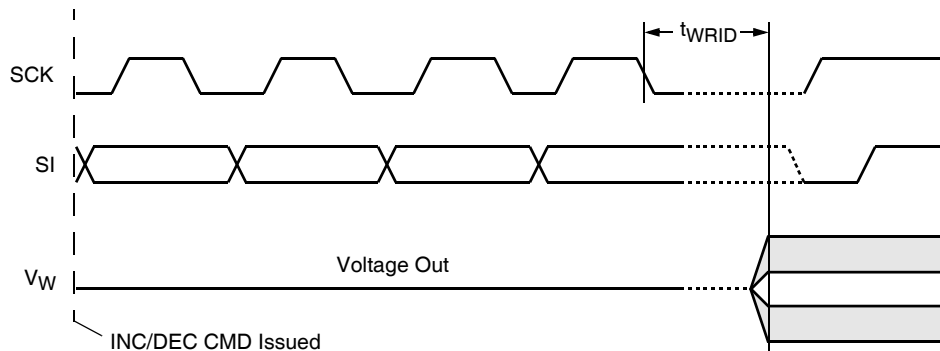

Table 3. Instruction Set

Instruction	Instruction Set								Operation
	I ₃	I ₂	I ₁	I ₀	R ₁	R ₀			
Read Wiper Counter Register	1	0	0	1	0	0	0	0	Read the contents of the Wiper Counter Register
Write Wiper Counter Register	1	0	1	0	0	0	0	0	Write new value to the Wiper Counter Register
Read Data Register	1	0	1	1	1/0	1/0	0	0	Read the contents of the Data Register pointed to by R ₁ - R ₀
Write Data Register	1	1	0	0	1/0	1/0	0	0	Write new value to the Data Register pointed to by R ₁ - R ₀
XFR Data Register to Wiper Counter Register	1	1	0	1	1/0	1/0	0	0	Transfer the contents of the Data Register pointed to by R ₁ - R ₀ to the Wiper Counter Register
XFR Wiper Counter Register to Data Register	1	1	1	0	1/0	1/0	0	0	Transfer the contents of the Wiper Counter Register to the Data Register pointed to by R ₁ - R ₀
Increment/Decrement Wiper Counter Register	0	0	1	0	0	0	0	0	Enable Increment/decrement of the Wiper Counter Register
Read Status (WIP bit)	0	1	0	1	0	0	0	1	Read the status of the internal write cycle, by checking the WIP bit.

Instruction Format

- Notes: (1) "A0": stands for the device addresses sent by the master.
 (2) WPx refers to wiper position data in the Wiper Counter Register
 "I": stands for the increment operation, SI held HIGH during active SCK phase (high).
 (3) "D": stands for the decrement operation, SI held LOW during active SCK phase (high).

Read Wiper Counter Register (WCR)

\overline{CS} Falling Edge	device type identifier		device addresses		instruction opcode		wiper position (sent by X9421 on SO)							\overline{CS} Rising Edge											
	0	1	0	1	1	1	0	A	0	1	0	0	1		0	0	0	0	0	0	W	W	W	W	W
																				P	P	P	P	P	P
																				5	4	3	2	1	0

Write Wiper Counter Register (WCR)

\overline{CS} Falling Edge	device type identifier		device addresses		instruction opcode		Data Byte (sent by Host on SI)							\overline{CS} Rising Edge											
	0	1	0	1	1	1	0	A	0	1	0	1	0		0	0	0	0	0	0	W	W	W	W	W
																				P	P	P	P	P	P
																				5	4	3	2	1	0

Read Data Register (DR)

Read the contents of the Register pointed to by R1 - R0.

\overline{CS} Falling Edge	device type identifier		device addresses		instruction opcode		register addresses		Data Byte (sent by X9421 on SO)							\overline{CS} Rising Edge									
	0	1	0	1	1	1	0	A	0	1	0	1	1	R	R		0	0	0	0	W	W	W	W	W
														1	0	0	0			P	P	P	P	P	P
														1	0	0	0			5	4	3	2	1	0

Write Data Register (DR)

Write a new value to the Register pointed to by R1 - R0.

\overline{CS} Falling Edge	device type identifier		device addresses		instruction opcode		register addresses		Data Byte (sent by host on SI)							\overline{CS} Rising Edge	HIGH-VOLTAGE WRITE CYCLE								
	0	1	0	1	1	1	0	A	0	1	1	0	0	R	R			0	0	0	0	W	W	W	W
														1	1	0	0			P	P	P	P	P	P
														1	1	0	0			5	4	3	2	1	0

Transfer Data Register (DR) to Wiper Counter Register (WCR)

Transfer the contents of the Register pointed to by R1 - R0 to the WCR.

\overline{CS} Falling Edge	device type identifier		device addresses		instruction opcode		register addresses		\overline{CS} Rising Edge				
	0	1	0	1	1	1	0	A		0	1	0	0

Transfer Wiper Counter Register (WCR) to Data Register (DR)

$\overline{\text{CS}}$ Falling Edge	device type identifier				device addresses				instruction opcode				register addresses				$\overline{\text{CS}}$ Rising Edge	HIGH-VOLTAGE WRITE CYCLE
	0	1	0	1	1	1	0	A 0	1	1	1	0	R 1	R 0	0	0		

Increment/Decrement Wiper Counter Register (WCR)

$\overline{\text{CS}}$ Falling Edge	device type identifier				device addresses				instruction opcode				increment/decrement (sent by master on SDA)						$\overline{\text{CS}}$ Rising Edge				
	0	1	0	1	1	1	0	A 0	0	0	1	0	0	0	0	0	I/D	I/D	

Read Status

$\overline{\text{CS}}$ Falling Edge	device type identifier				device addresses				instruction opcode				Data Byte (sent by X9421 on SO)								$\overline{\text{CS}}$ Rising Edge							
	0	1	0	1	1	1	0	A 0	0	1	0	1	0	0	0	1	0	0	0	0		0	0	0	0	0	0	0

ABSOLUTE MAXIMUM RATINGS

Temperature under bias. -65°C to +135°C
 Storage temperature -65°C to +150°C
 Voltage on SCK any address input
 with respect to V_{SS}. -1V to +7V
 $\Delta V = | (V_H - V_L) |$ 5V
 Lead temperature (soldering, 10 seconds) 300°C
 I_W (10 seconds) ±6mA
 Any V_H/R_H, V_L/R_L, V_W/R_W V_{SS} to V_{CC}

COMMENT

Stresses above those listed under “Absolute Maximum Ratings” may cause permanent damage to the device. This is a stress rating only; functional operation of the device (at these or any other conditions above those listed in the operational sections of this specification) is not implied. Exposure to absolute maximum rating conditions for extended periods may affect device reliability.

RECOMMENDED OPERATING CONDITIONS

Temp	Min.	Max.
Commercial	0°C	+70°C
Industrial	-40°C	+85°C

Device	Supply Voltage (V _{CC}) Limits
X9421	5V ± 10%
X9421-2.7	2.7V to 5.5V

ANALOG CHARACTERISTICS (Over recommended operating conditions unless otherwise stated.)

Symbol	Parameter	Limits				Test Conditions
		Min.	Typ.	Max.	Units	
	End to End Resistance Tolerance			±20	%	
	Power Rating			50	mW	25°C, each pot
I _W	Wiper Current			±3	mA	
R _W	Wiper Resistance		150	250	Ω	Wiper Current = ± 1mA, V _{CC} = 5V
			400	1000	Ω	Wiper Current = ± 1mA, V _{CC} = 3V
V _{TERM}	Voltage on any V _H /R _H , V _L /R _L , V _W /R _W	V _{SS}		V _{CC}	V	V _{SS} = 0V
	Noise		-120		dBV	Ref: 1kHz
	Resolution ⁽⁴⁾		1.6		%	See Note 5
	Absolute Linearity ⁽¹⁾			±1	MI ⁽³⁾	V _{w(n)(actual)} - V _{w(n)(expected)}
	Relative Linearity ⁽²⁾			±0.2	MI ⁽³⁾	V _{w(n+1)} - [V _{w(n)} + MI]
	Temperature Coefficient of R _{TOTAL}		±300		ppm/°C	See Note 5
	Ratiometric Temperature Coefficient			±20	ppm/°C	See Note 5
C _H /C _L /C _W	Potentiometer Capacitances		10/10/25		pF	See Circuit #3
I _{AL}	R _h , R _l , R _w leakage current		0.1	10	μA	V _{in} = V _{ss} to V _{cc} . Device is in stand-by mode.

- Notes: (1) Absolute Linearity is utilized to determine actual wiper voltage versus expected voltage as determined by wiper position when used as a potentiometer.
 (2) Relative Linearity is utilized to determine the actual change in voltage between two successive tap positions when used as a potentiometer. It is a measure of the error in step size.
 (3) MI = RTOT/63 or (V_H - V_L)/63, single pot
 (4) Typical = Individual array resolution.

D.C. OPERATING CHARACTERISTICS (Over the recommended operating conditions unless otherwise specified.)

Symbol	Parameter	Limits				Test Conditions
		Min.	Typ.	Max.	Units	
I _{CC1}	V _{CC} Supply Current (Active)			400	μA	f _{SCK} = 2MHz, SO = Open, Other Inputs = V _{SS}
I _{CC2}	V _{CC} Supply Current (Non-volatile Write)			1	mA	f _{SCK} = 2MHz, SO = Open, Other Inputs = V _{SS}
I _{SB}	V _{CC} Current (Standby)			1	μA	SCK = SI = V _{SS} , Addr. = V _{SS}
I _{LI}	Input Leakage Current			10	μA	V _{IN} = V _{SS} to V _{CC}
I _{LO}	Output Leakage Current			10	μA	V _{OUT} = V _{SS} to V _{CC}
V _{IH}	Input HIGH Voltage	V _{CC} x 0.7		V _{CC} + 0.5	V	
V _{IL}	Input LOW Voltage	-0.5		V _{CC} x 0.1	V	
V _{OL}	Output LOW Voltage			0.4	V	I _{OL} = 3mA

ENDURANCE AND DATA RETENTION

Parameter	Min.	Units
Minimum Endurance	100,000	Data Changes per Bit per Register
Data Retention	100	Years

CAPACITANCE

Symbol	Test	Max.	Units	Test Conditions
C _{OUT} ⁽⁵⁾	Output Capacitance (SO)	8	pF	V _{OUT} = 0V
C _{IN} ⁽⁵⁾	Input Capacitance (A0, SI, and SCK)	6	pF	V _{IN} = 0V

POWER-UP TIMING

Symbol	Parameter	Max.	Max.	Units
t _R V _{CC} ⁽⁵⁾	V _{CC} Power-up Ramp	0.2	50	V/msec

POWER-UP REQUIREMENTS (Power-up sequencing can affect correct recall of the wiper registers)

The preferred power-on sequence is as follows: First V_{CC} and then the potentiometer pins, R_H, R_L, and R_W. Voltage should not be applied to the potentiometer pins before V_{CC} is applied. The V_{CC} ramp rate specification should be met, and any glitches or slope changes in the V_{CC} line should be held to <100mV if possible. Also, V_{CC} should not reverse polarity by more than 0.5V. Recall of wiper position will not be complete until V_{CC} reaches its final value.

Notes: (5) This parameter is periodically sampled and not 100% tested.

A.C. TEST CONDITIONS

Input pulse levels	V _{CC} x 0.1 to V _{CC} x 0.9
Input rise and fall times	10ns
Input and output timing level	V _{CC} x 0.5

EQUIVALENT A.C. LOAD CIRCUIT

Circuit #3 SPICE Macro Model

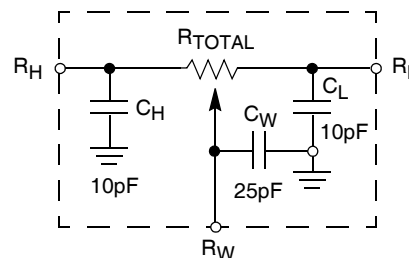
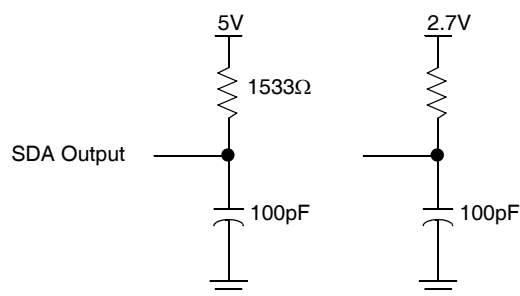

AC TIMING

Symbol	Parameter	Min.	Max.	Units
f _{SCK}	SSI/SPI Clock Frequency		2.0	MHz
t _{CYC}	SSI/SPI Clock Cycle Time	500		ns
t _{WH}	SSI/SPI Clock High Time	200		ns
t _{WL}	SSI/SPI Clock Low Time	200		ns
t _{LEAD}	Lead Time	250		ns
t _{LAG}	Lag Time	250		ns
t _{SU}	SI, SCK, $\overline{\text{HOLD}}$ and $\overline{\text{CS}}$ Input Setup Time	50		ns
t _H	SI, SCK, $\overline{\text{HOLD}}$ and $\overline{\text{CS}}$ Input Hold Time	50		ns
t _{RI}	SI, SCK, $\overline{\text{HOLD}}$ and $\overline{\text{CS}}$ Input Rise Time		2	μs
t _{FI}	SI, SCK, $\overline{\text{HOLD}}$ and $\overline{\text{CS}}$ Input Fall Time		2	μs
t _{DIS}	SO Output Disable Time	0	500	ns
t _V	SO Output Valid Time		100	ns
t _{HO}	SO Output Hold Time	0		ns
t _{RO}	SO Output Rise Time		50	ns
t _{FO}	SO Output Fall Time		50	ns
t _{HOLD}	HOLD Time	400		ns
t _{HSU}	$\overline{\text{HOLD}}$ Setup Time	100		ns
t _{HH}	$\overline{\text{HOLD}}$ Hold Time	100		ns
t _{HZ}	$\overline{\text{HOLD}}$ Low to Output in High Z		100	ns
t _{LZ}	$\overline{\text{HOLD}}$ High to Output in Low Z		100	ns
T _I	Noise Suppression Time Constant at SI, SCK, $\overline{\text{HOLD}}$ and $\overline{\text{CS}}$ inputs		20	ns
t _{CS}	$\overline{\text{CS}}$ Deselect Time	2		μs
t _{WPASU}	$\overline{\text{WP}}$, A0 and A1 Setup Time	0		ns
t _{WPAH}	$\overline{\text{WP}}$, A0 and A1 Hold Time	0		ns





HIGH-VOLTAGE WRITE CYCLE TIMING

Symbol	Parameter	Typ.	Max.	Units
t _{WR}	High-voltage Write Cycle Time (Store Instructions)	5	10	ms

XDCP TIMING

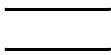
Symbol	Parameter	Min.	Max.	Units
t _{WRPO}	Wiper Response Time After The Third (Last) Power Supply Is Stable		10	μs
t _{WRL}	Wiper Response Time After Instruction Issued (All Load Instructions)		10	μs
t _{WRID}	Wiper Response Time From An Active SCL/SCK Edge (Increment/Decrement Instruction)		450	ns

SYMBOL TABLE

WAVEFORM	INPUTS	OUTPUTS
	Must be steady	Will be steady
	May change from Low to High	Will change from Low to High
	May change from High to Low	Will change from High to Low
	Don't Care: Changes Allowed	Changing: State Not Known
	N/A	Center Line is High Impedance

TIMING DIAGRAMS

Input Timing

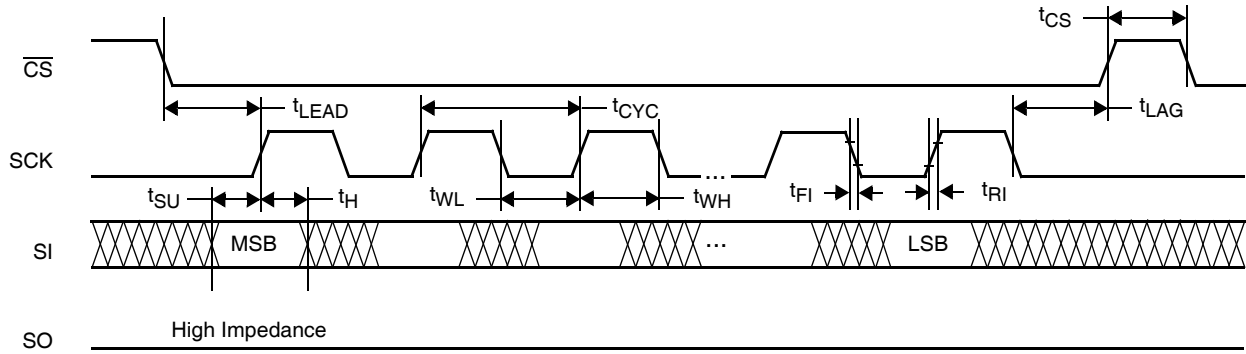

Output Timing

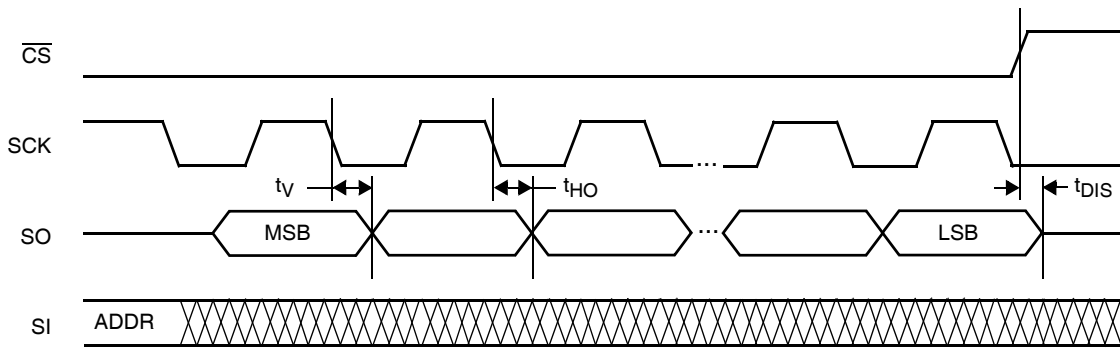

Hold Timing

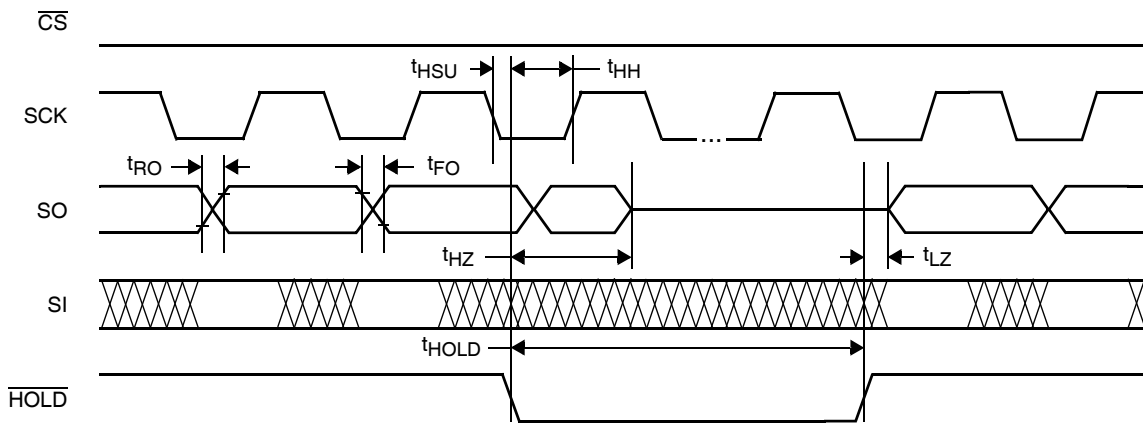

XDCP Timing (for All Load Instructions)

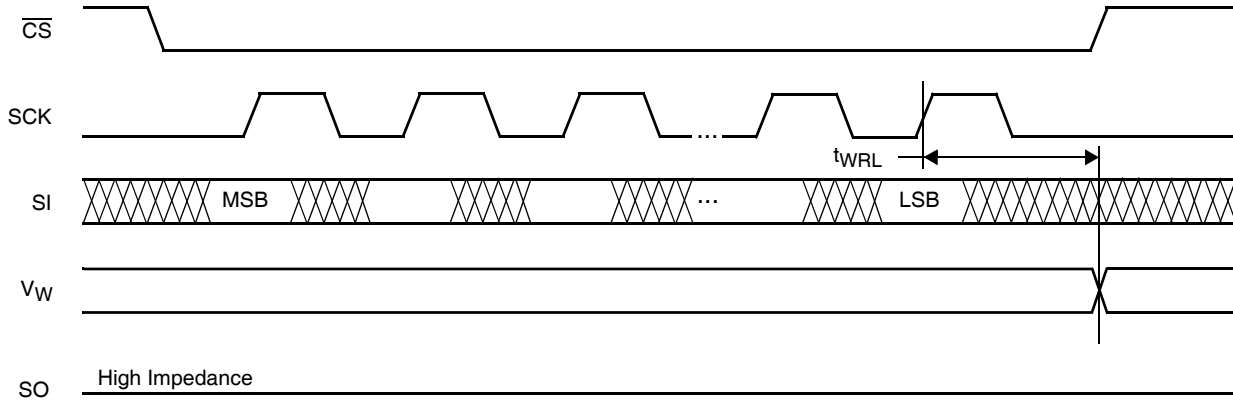

XDCP Timing (for Increment/Decrement Instruction)

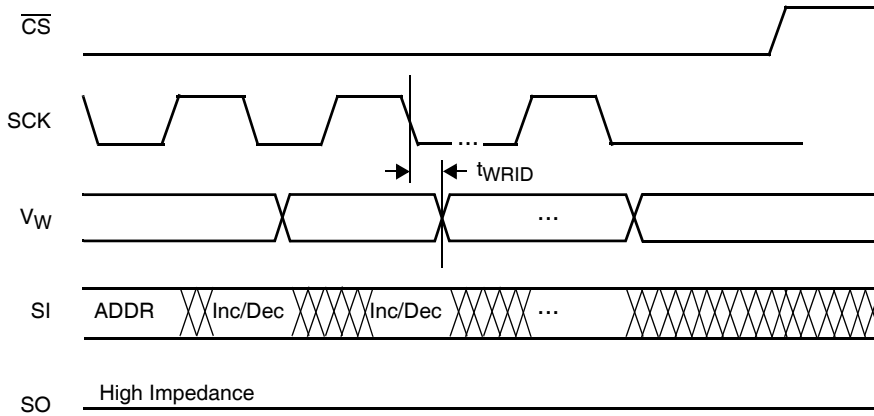

Write Protect and Device Address Pins Timing

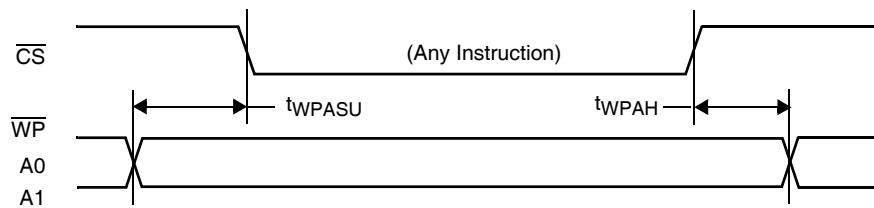

APPLICATIONS INFORMATION

Electronic potentiometers provide three powerful application advantages: (1) the variability and reliability of a solid-state potentiometer, (2) the flexibility of computer-based digital controls, and (3) the retentivity of nonvolatile memory used for the storage of multiple potentiometer settings or data.

Basic Configurations of Electronic Potentiometers

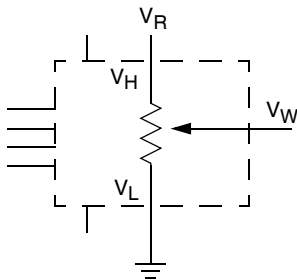

Three terminal Potentiometer;
Variable voltage divider

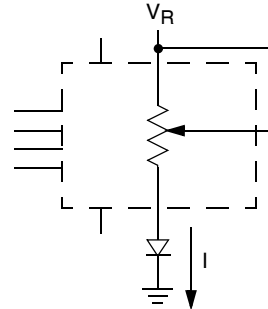

Two terminal Variable Resistor;
Variable current

Basic Circuits

Buffered Reference Voltage

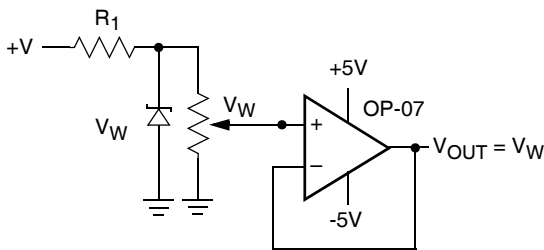

Cascading Techniques

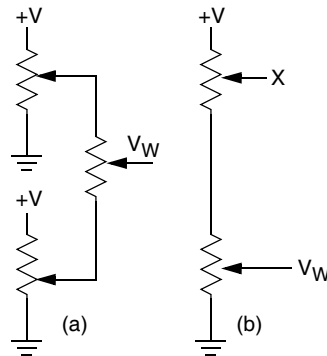

Noninverting Amplifier

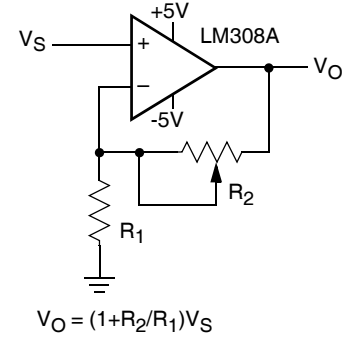

Voltage Regulator

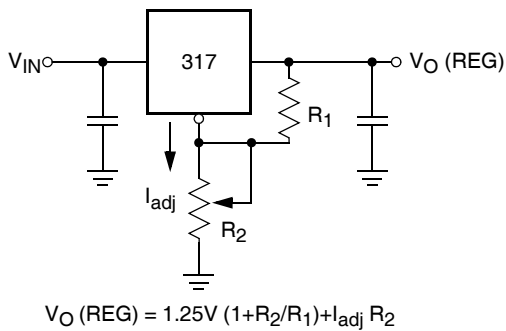

Offset Voltage Adjustment

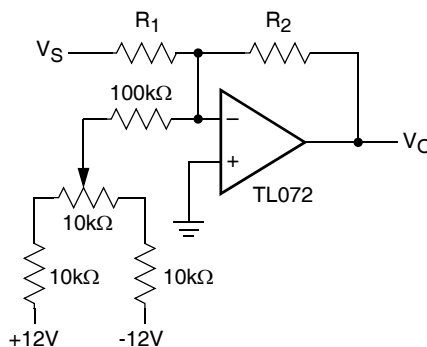

Comparator with Hysteresis

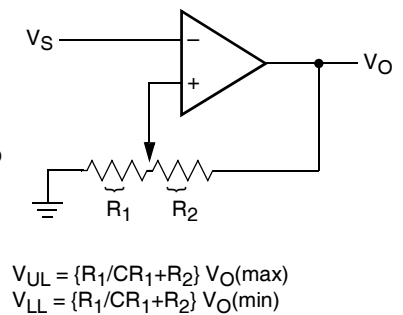

PACKAGING INFORMATION

16-Lead Plastic SOIC (300 Mil Body) Package Type S

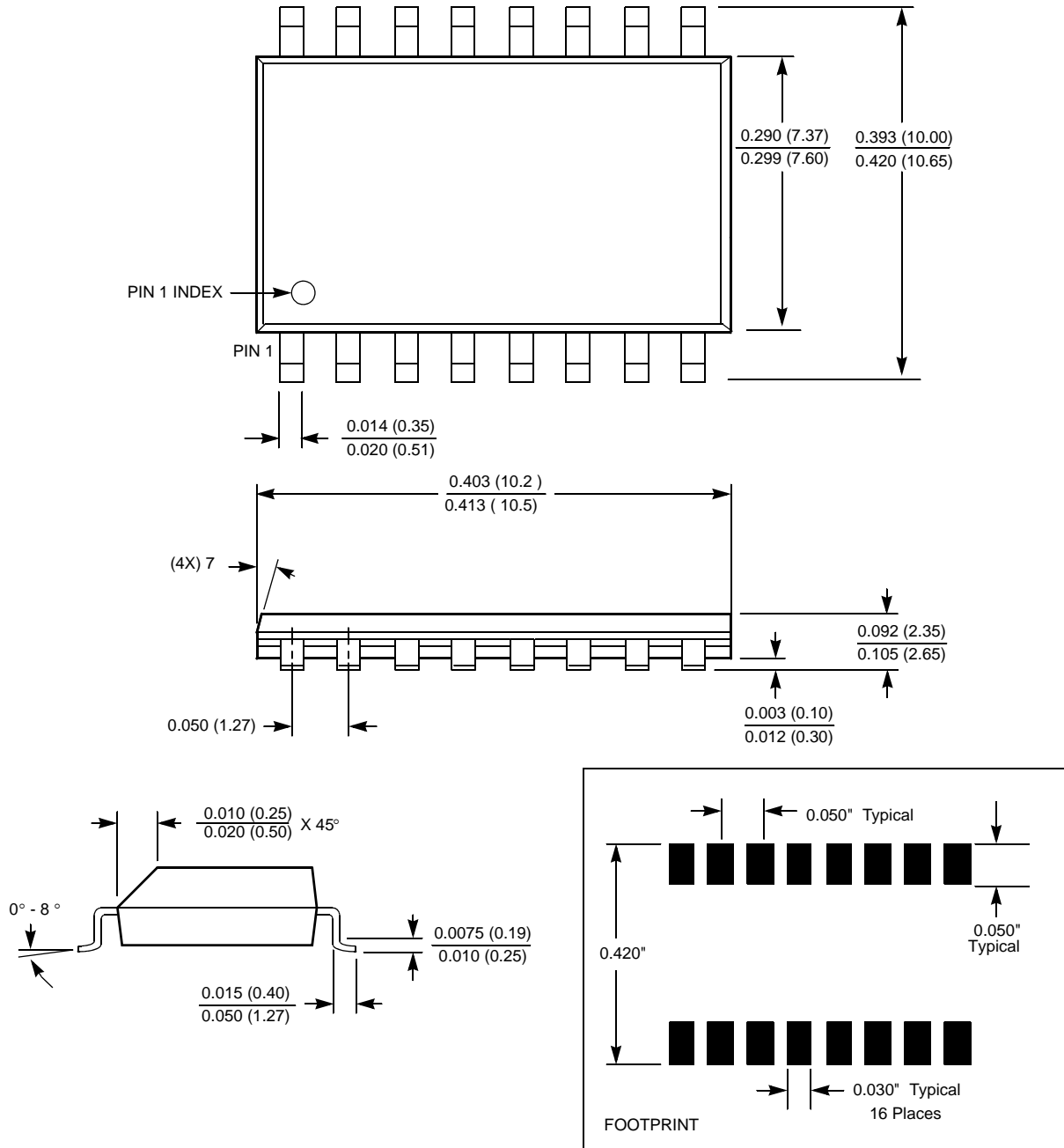

NOTE: ALL DIMENSIONS IN INCHES (IN PARENTHESES IN MILLIMETERS)

PACKAGING INFORMATION

14-Lead Plastic, TSSOP, Package Type V

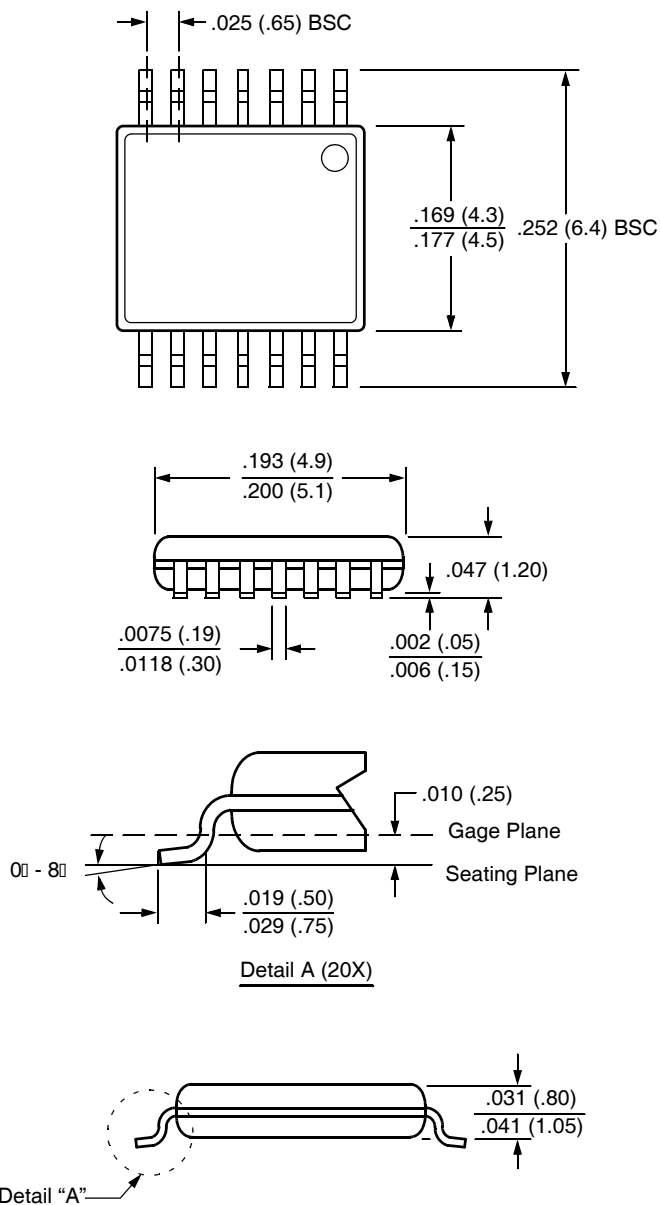

NOTE: ALL DIMENSIONS IN INCHES (IN PARENTHESES IN MILLIMETERS)

All Intersil U.S. products are manufactured, assembled and tested utilizing ISO9000 quality systems. Intersil Corporation's quality certifications can be viewed at www.intersil.com/design/quality

Intersil products are sold by description only. Intersil Corporation reserves the right to make changes in circuit design, software and/or specifications at any time without notice. Accordingly, the reader is cautioned to verify that data sheets are current before placing orders. Information furnished by Intersil is believed to be accurate and reliable. However, no responsibility is assumed by Intersil or its subsidiaries for its use; nor for any infringements of patents or other rights of third parties which may result from its use. No license is granted by implication or otherwise under any patent or patent rights of Intersil or its subsidiaries.

For information regarding Intersil Corporation and its products, see www.intersil.com

X9421

[Printer Friendly Version](#)

Single Digitally Controlled (XDCP™) Potentiometer

 Datasheets, Related Docs & Simulations	 Description	 Key Features	 Parametric Data	 Application Diagrams	 Related Devices
--	---	--	---	--	---

Ordering Information

 **RoHS/Pb-Free/Green Device**

Part No.	Design-In Status	Temp.	Package	MSL	Price US \$	
X9421WS16	Active	Comm	16 Ld SOIC	1	2.15	Buy
X9421WS16-2.7	Active	Comm	16 Ld SOIC	1	2.36	Buy
X9421WS16-2.7T1	Active	Comm	16 Ld SOIC T+R	1	2.36	Buy
X9421WS16I	Active	Ind	16 Ld SOIC	1	2.69	Buy
X9421WS16I-2.7	Active	Ind	16 Ld SOIC	1	2.96	Buy Sample
X9421WS16I-2.7T1	Active	Ind	16 Ld SOIC T+R	1	2.96	Buy
X9421WS16IT1	Active	Ind	16 Ld SOIC T+R	1	2.69	Buy
X9421WS16IZ 	Active	Ind	16 Ld SOIC	3	2.69	Buy
X9421WS16IZ-2.7 	Active	Ind	16 Ld SOIC	3	2.96	Buy
X9421WS16IZ-2.7T1 	Active	Ind	16 Ld SOIC T+R	3	2.96	Buy
X9421WS16IZT1 	Active	Ind	16 Ld SOIC T+R	3	2.69	Buy
X9421WS16T1	Active	Comm	16 Ld SOIC T+R	1	2.15	Buy
X9421WS16Z 	Active	Comm	16 Ld SOIC	3	2.15	Buy
X9421WS16Z-2.7 	Active	Comm	16 Ld SOIC	3	2.36	Buy
X9421WS16Z-2.7T1 	Active	Comm	16 Ld SOIC T+R	3	2.36	Buy
X9421WS16ZT1 	Active	Comm	16 Ld SOIC T+R	3	2.15	Buy
X9421WV14	Active	Comm	14 Ld TSSOP	1	2.54	Buy
X9421WV14-2.7	Active	Comm	14 Ld TSSOP	1	2.79	Buy
X9421WV14-2.7T1	Active	Comm	14 Ld TSSOP T+R	1	2.79	Buy
X9421WV14I	Active	Ind	14 Ld TSSOP	1	3.17	Buy
X9421WV14I-2.7	Active	Ind	14 Ld TSSOP	1	3.48	Buy Sample
X9421WV14I-2.7T1	Active	Ind	14 Ld TSSOP T+R	1	3.48	Buy
X9421WV14IT1	Active	Ind	14 Ld TSSOP T+R	1	3.17	Buy
X9421WV14IZ 	Active	Ind	14 Ld TSSOP	1	3.17	Buy
X9421WV14IZ-2.7 	Active	Ind	14 Ld TSSOP	1	3.48	Buy
X9421WV14IZ-2.7T1 	Active	Ind	14 Ld TSSOP T+R	1	3.48	Buy
X9421WV14IZT1 	Active	Ind	14 Ld TSSOP T+R	1	3.17	Buy
X9421WV14T1	Active	Comm	14 Ld TSSOP T+R	1	2.54	Buy
X9421WV14Z 	Active	Comm	14 Ld TSSOP	1	2.54	Buy
X9421WV14Z-2.7 	Active	Comm	14 Ld TSSOP	1	2.79	Buy
X9421WV14Z-2.7T1 	Active	Comm	14 Ld TSSOP T+R	1	2.79	Buy
X9421WV14ZT1 	Active	Comm	14 Ld TSSOP T+R	1	2.54	Buy

X9421YP18I	Active	Ind	18 Ld PDIP	N/A	3.51	Buy
X9421YS16	Active	Comm	16 Ld SOIC	1	2.15	Buy
X9421YS16-2.7	Active	Comm	16 Ld SOIC	1	2.36	Buy
X9421YS16-2.7T1	Active	Comm	16 Ld SOIC T+R	1	2.36	Buy
X9421YS16I	Active	Ind	16 Ld SOIC	1	2.69	Buy
X9421YS16I-2.7	Active	Ind	16 Ld SOIC	1	2.96	Buy
X9421YS16I-2.7T1	Active	Ind	16 Ld SOIC T+R	1	2.96	Buy
X9421YS16IT1	Active	Ind	16 Ld SOIC T+R	1	2.69	Buy
X9421YS16IZ 	Active	Ind	16 Ld SOIC	3	2.69	Buy
X9421YS16IZ-2.7 	Active	Ind	16 Ld SOIC	3	2.96	Buy
X9421YS16IZ-2.7T1 	Active	Ind	16 Ld SOIC T+R	3	2.96	Buy
X9421YS16IZT1 	Active	Ind	16 Ld SOIC T+R	3	2.69	Buy
X9421YS16T1	Active	Comm	16 Ld SOIC T+R	1	2.15	Buy
X9421YS16Z 	Active	Comm	16 Ld SOIC	3	2.15	Buy
X9421YS16Z-2.7 	Active	Comm	16 Ld SOIC	3	2.36	Buy
X9421YS16Z-2.7T1 	Active	Comm	16 Ld SOIC T+R	3	2.36	Buy
X9421YS16ZT1 	Active	Comm	16 Ld SOIC T+R	3	2.15	Buy
X9421YV14	Active	Comm	14 Ld TSSOP	1	2.54	Buy
X9421YV14-2.7	Active	Comm	14 Ld TSSOP	1	2.79	Buy
X9421YV14-2.7T1	Active	Comm	14 Ld TSSOP T+R	1	2.79	Buy
X9421YV14I	Active	Ind	14 Ld TSSOP	1	3.17	Buy
X9421YV14I-2.7	Active	Ind	14 Ld TSSOP	1	3.48	Buy Sample
X9421YV14I-2.7T1	Active	Ind	14 Ld TSSOP T+R	1	3.48	Buy
X9421YV14IT1	Active	Ind	14 Ld TSSOP T+R	1	3.17	Buy
X9421YV14IZ 	Active	Ind	14 Ld TSSOP	1	3.17	Buy
X9421YV14IZ-2.7 	Active	Ind	14 Ld TSSOP	1	3.48	Buy
X9421YV14IZ-2.7T1 	Active	Ind	14 Ld TSSOP T+R	1	3.48	Buy
X9421YV14IZT1 	Active	Ind	14 Ld TSSOP T+R	1	3.17	Buy
X9421YV14T1	Active	Comm	14 Ld TSSOP T+R	1	2.54	Buy
X9421YV14Z 	Active	Comm	14 Ld TSSOP	1	2.54	Buy
X9421YV14Z-2.7 	Active	Comm	14 Ld TSSOP	1	2.78	Buy
X9421YV14Z-2.7T1 	Active	Comm	14 Ld TSSOP T+R	1	2.78	Buy
X9421YV14ZT1 	Active	Comm	14 Ld TSSOP T+R	1	2.54	Buy

The price listed is the manufacturer's suggested retail price for quantities between 100 and 999 units. However, prices in today's market are fluid and may change without notice.

MSL = Moisture Sensitivity Level - per IPC/JEDEC J-STD-020

SMD = Standard Microcircuit Drawing

Description

The X9421 integrates a single digitally controlled potentiometer (XDCP) on a monolithic CMOS integrated circuit.

The digital controlled potentiometer is implemented using 63 resistive elements in a series array. Between each element are tap points connected to the wiper terminal through switches. The position of the wiper on the array is controlled by the user through the SPI bus interface. The potentiometer has associated with it a volatile Wiper Counter Register (WCR) and a four nonvolatile Data Registers that can be directly written to and read by the user. The contents of the WCR controls the position of the wiper on the resistor array through the switches. Powerup recalls

the contents of the default data register (DR0) to the WCR.

The XDCP can be used as a three-terminal potentiometer or as a two terminal variable resistor in a wide variety of applications including control, parameter adjustments, and signal processing.

Key Features

- Single Voltage Potentiometer
- 64 Resistor Taps
- SPI Serial Interface for Write, Read, and Transfer Operations of the Potentiometer
- Wiper Resistance, 150Ω Typical at 5V
- 4 Non-Volatile Data Registers
- Non-Volatile Storage of Multiple Wiper Positions
- Power-on Recall. Loads Saved Wiper Position on Power-up.
- Standby Current <5μA Max
- V_{CC}: 2.7V to 5.5V Operation
- 2.5kΩ, 10kΩ End to End Resistance
- 100 yr. Data Retention
- Endurance: 100, 000 Data Changes per Bit per Register
- 14 Ld TSSOP, 16 Ld SOIC
- Low Power CMOS
- Pb-Free Plus Anneal Available (RoHS Compliant)

Related Documentation



Application Note(s):

- [A Compendium of Application Circuits for Intersil's Digitally-Controlled \(XDCP\) Potentiometers](#)
- [A Primer on Digitally-Controlled Potentiometers](#)
- [Application of Intersil Digitally Controlled Potentiometers \(XDCP™\) as Hybrid Analog/Digital Feedback System Control Elements](#)
- [DC/DC Module Trim with Digital Potentiometers](#)
- [Designing Power Supplies Using Intersil's XDCP Mixed Signal Products](#)
- [Power Supply and DC to DC Converter Control using Intersil Digitally Controlled Potentiometers \(XDCPs\)](#)
- [Putting Analog On The Bus](#)
- [Shaft Encoder Drives Multiple Intersil Digitally Controlled Potentiometers \(XDCPs\)](#)
- [Tone, Balance, and Volume Control using a Quad XDCP](#)



Datasheet(s):

- [Single Digitally Controlled \(XDCP™\) Potentiometer](#)



Technical Brief(s):

- [Converting a Fixed PWM to an Adjustable PWM](#)



Evaluation Board(s):

- [Intersil_XDCP_Test_UTILITY_Manual_rev_3.2.3.pdf](#)
- [LabView_XDCP_Software.zip](#)
- [LabView_XDCP_Upgrade_3.2.3.zip](#)
- [Readme_XicorLabVIEW_V3.2.3.txt](#)
- [accessHW.zip](#)



Technical Homepage:

- [Digitally Controlled Potentiometers \(DCPs\) and Capacitors \(DCCs\)](#)
- [Precision Analog Homepage](#)



Parametric Data

Number of DCPs	Single
Number of Taps	64
Memory Type	Non-Volatile
Bus Interface Type	SPI
Resistance Options (kΩ)	2.5, 10
V _{CC} Range (V)	2.7 to 5.5
DCP Differential Terminal Voltage (V)	0 to +5.5
Terminal Voltage Range V _L to V _H (V)	0 to V _{CC}
Resistance Taper	Linear
Wiper Current (mA)	±3
Wiper Resistance (Ω)	250
Standby Current I _{SB} (μA)	1

Application Block Diagrams

- [LCD-TV Panel](#)
- [Satellite Radio](#)
- [Security CCTV](#)

Applications

- CIRCUIT LEVEL APPLICATIONS
- Vary the gain of a voltage amplifier
- Provide programmable dc reference voltages for comparators and detectors
- Control the volume in audio circuits
- Trim out the offset voltage error in a voltage amplifier circuit
- Set the output voltage of a voltage regulator
- Trim the resistance in Wheatstone bridge circuits
- Control the gain, characteristic frequency and Q-factor in filter circuits
- Set the scale factor and zero point in sensor signal conditioning circuits
- Vary the frequency and duty cycle of timer ICs
- Vary the dc biasing of a pin diode attenuator in RF circuits
- Provide a control variable (I, V, or R) in feedback circuits
- SYSTEM LEVEL APPLICATIONS
- Adjust the contrast in LCD displays
- Control the power level of LED transmitters in communication systems
- Set and regulate the DC biasing point in an RF power amplifier in wireless systems
- Control the gain in audio and home entertainment systems
- Provide the variable DC bias for tuners in RF wireless systems
- Set the operating points in temperature control systems
- Control the operating point for sensors in industrial systems
- Trim offset and gain errors in artificial intelligent systems

Related Devices

 [Parametric Table](#)

- [X9420](#) Single Digitally Controlled (XDCP™) Potentiometer
- [X9428](#) Single Digitally Controlled Potentiometer (XDCP™)
- [X9429](#) Single Digitally Controlled Potentiometer (XDCP™)