

1M x 16-Bit Dynamic RAM (1k & 4k-Refresh)

HYB 3116160BSJ/BST(L)-50/-60/-70
HYB 3118160BSJ/BST(L)-50/-60/-70

Advanced Information

- 1 048 576 words by 16-bit organization
- 0 to 70 °C operating temperature
- Performance:

		-50	-60	-70	
t_{RAC}	\overline{RAS} access time	50	60	70	ns
t_{CAC}	\overline{CAS} access time	13	15	20	ns
t_{AA}	Access time from address	25	30	35	ns
t_{RC}	Read/Write cycle time	90	110	130	ns
t_{PC}	Fast page mode cycle time	35	40	45	ns

- Single + 3.3 V (± 0.3 V) supply
- Low power dissipation
 - max. 720 active mW (HYB 3118160BSJ/BST-50)
 - max. 648 active mW (HYB 3118160BSJ/BST-60)
 - max. 576 active mW (HYB 3118160BSJ/BST-70)
 - max. 360 active mW (HYB 3116160BSJ/BST-50)
 - max. 324 active mW (HYB 3116160BSJ/BST-60)
 - max. 288 active mW (HYB 3116160BSJ/BST-70)
 - 7.2 mW standby (LV-TTL)
 - 3.6 mW standby (LV-CMOS)
 - 720 μ W standby for L-version
- Output unlatched at cycle end allows two-dimensional chip selection
- Read, write, read-modify-write, \overline{CAS} -before- \overline{RAS} refresh, \overline{RAS} -only refresh, hidden refresh, self refresh
- Fast page mode capability
- 2 \overline{CAS} / 1 WE
- All inputs, outputs and clocks fully LV-TTL-compatible
- 1024 refresh cycles / 16 ms for HYB 3118160BSJ
- 4096 refresh cycles / 64 ms for HYB 3116160BSJ
- Plastic Package: P-SOJ-42-1 400 mil
P-TSOPII-50/44-1 400mil

The HYB 3116(8)160BSJ/BST is a 16 MBit dynamic RAM organized as 1 048 576 words by 16 bits. The HYB 3116(8)160BSJ/BST utilizes a submicron CMOS silicon gate process technology, as well as advanced circuit techniques to provide wide operating margins, both internally and for the system user. Multiplexed address inputs permit the HYB 3116(8)160BSJ/BST to be packaged in standard SOJ-42 and TSOPII-50/44 plastic package with 400mil width. These packages provide high system bit densities and are compatible with commonly used automatic testing and insertion equipment. System-oriented features include single + 3.3 V (± 0.3 V) power supply, direct interfacing with high-performance logic device families. The HYB3116160BSTL parts have a very low power „sleep mode“ supported by Self Refresh.

Ordering Information

Type	Ordering Code	Package	Descriptions
HYB 3116160BSJ-50	Q67100-Q1224	P-SOJ-42 400 mil	DRAM (access time 50 ns)
HYB 3116160BSJ-60	Q67100-Q1226	P-SOJ-42 400 mil	DRAM (access time 60 ns)
HYB 3116160BSJ-70	on request	P-SOJ-42 400 mil	DRAM (access time 70 ns)
HYB 3118160BSJ-50	Q67100-Q1155	P-SOJ-42 400 mil	DRAM (access time 50 ns)
HYB 3118160BSJ-60	Q67100-Q1156	P-SOJ-42 400 mil	DRAM (access time 60 ns)
HYB 3118160BSJ-70	on request	P-SOJ-42 400 mil	DRAM (access time 70 ns)
HYB 3116160BST-50	on request	P-TSOPII-50/44 400 mil	DRAM (access time 50 ns)
HYB 3116160BST-60	on request	P-TSOPII-50/44 400 mil	DRAM (access time 60 ns)
HYB 3116160BST-70	on request	P-TSOPII-50/44 400 mil	DRAM (access time 70 ns)
HYB 3118160BST-50	Q67100-Q1163	P-TSOPII-50/44 400 mil	DRAM (access time 50 ns)
HYB 3118160BST-60	Q67100-Q1164	P-TSOPII-50/44 400 mil	DRAM (access time 60 ns)
HYB 3118160BST-70	on request	P-TSOPII-50/44 400 mil	DRAM (access time 70 ns)

Pin Names

A0 to A9	Row Address Inputs for 1k-refresh version HYB3118160BSJ/BST
A0 to A9	Column Address Inputs for 1k-refresh version HYB3118160BSJ/BST
A0 to A11	Row Address Inputs for 4k-refresh version HYB3116160BSJ/BST
A0 to A7	Column Address Inputs for 4k-refresh version HYB3116160BSJ/BST
RAS	Row Address Strobe
OE	Output Enable
I/O1-I/O16	Data Input/Output
UCAS	Upper Column Address Strobe
LCAS	Lower Column Address Strobe
WE	Read/Write Input
V _{CC}	Power Supply (+ 3.3 V)
V _{SS}	Ground (0 V)
N.C.	not connected

Pin Configuration (top view)

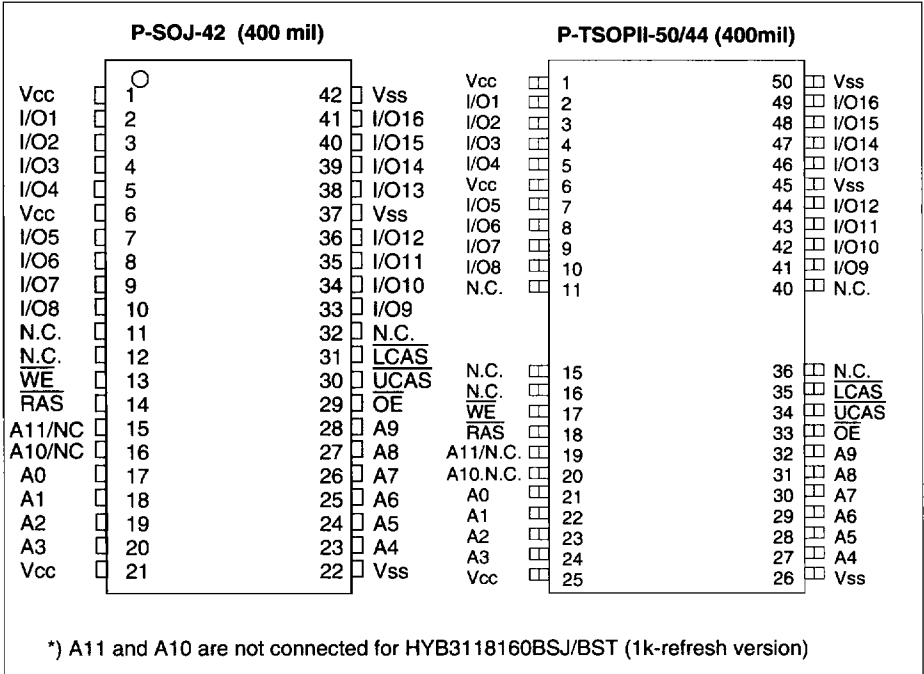

Truth Table

RAS	LCAS	UCAS	WE	OE	I/O1-I/O8	I/O9-I/O16	Operation
H	H	H	H	H	High-Z	High-Z	Standby
L	H	H	H	H	High-Z	High-Z	Refresh
L	L	H	H	L	Dout	High-Z	Lower byte read
L	H	L	H	L	High-Z	Dout	Upper byte read
L	L	L	H	L	Dout	Dout	Word read
L	L	H	L	H	Din	Don't care	Lower byte write
L	H	L	L	H	Don't care	Din	Upper byte write
L	L	L	L	H	Din	Din	Word write
L	L	L	H	H	High-Z	High-Z	NOP

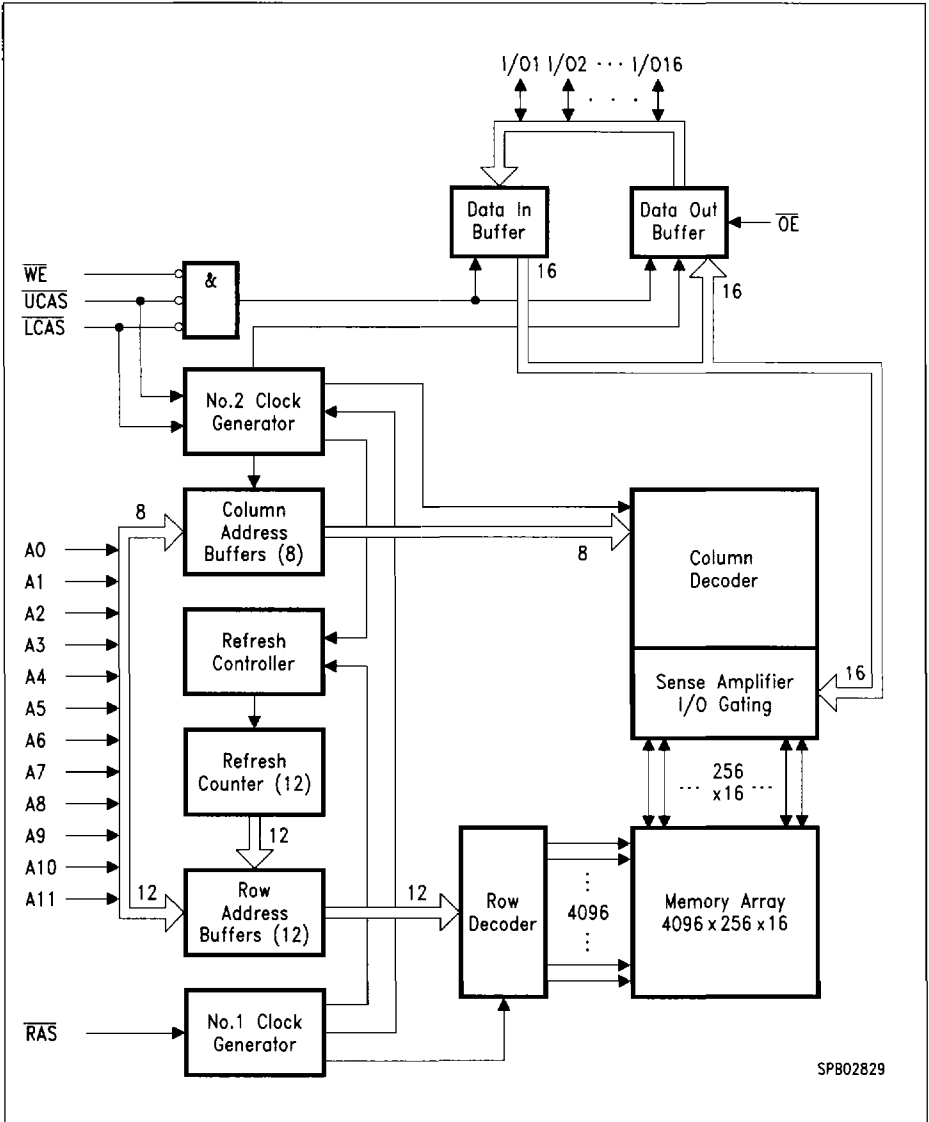

Block Diagram for HYB 3116160BSJ

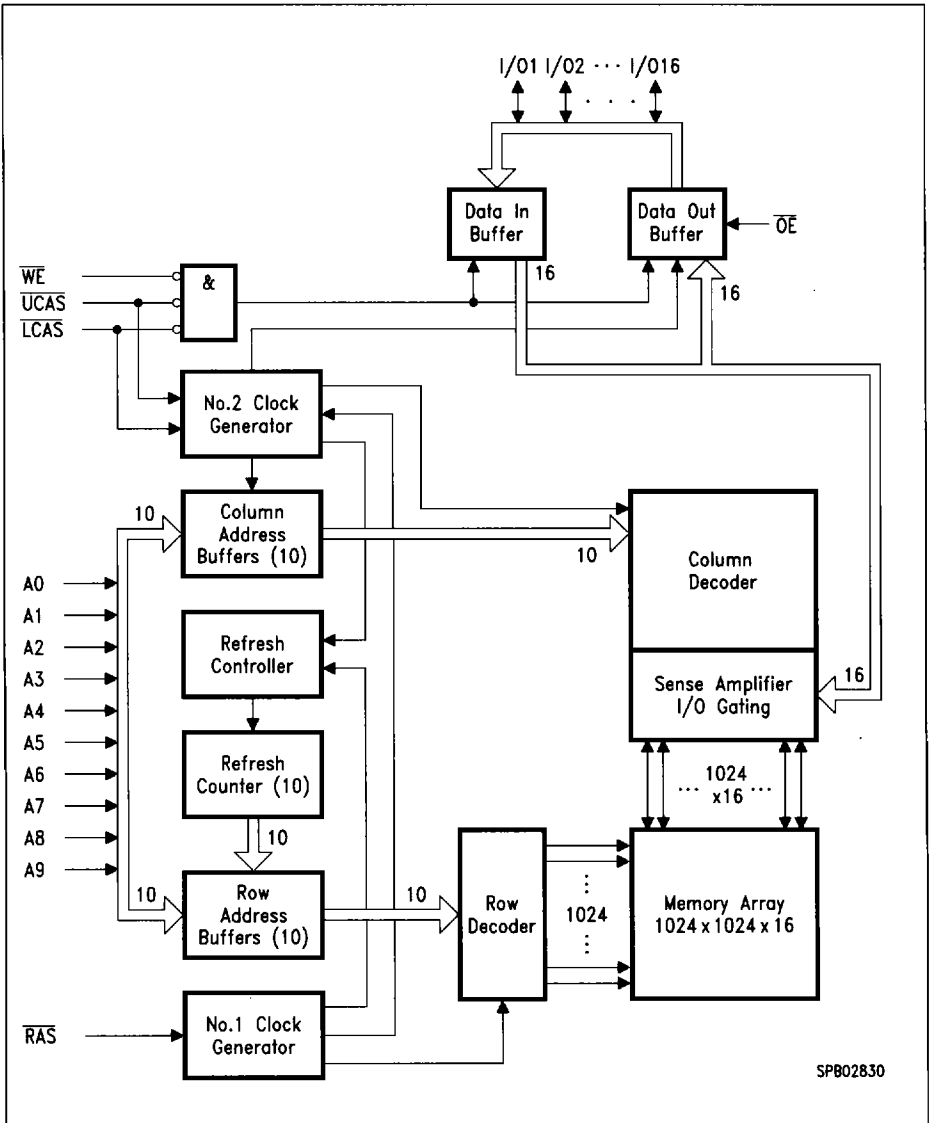

SPB02830

Block Diagram for HYB 3116(8)160BSJ

Absolute Maximum Ratings

Operating temperature range	0 to 70 °C
Storage temperature range.....	- 55 to 150 °C
Soldering time	10 s
Input/output voltage	- 0.5 to min ($V_{CC} + 0.5$, 4.6) V
Power supply voltage.....	- 0.5 V to 4.6 V
Power dissipation.....	1.0 W
Data out current (short circuit)	50 mA

Note: Stresses above those listed under "Absolute Maximum Ratings" may cause permanent damage of the device. Exposure to absolute maximum rating conditions for extended periods may affect device reliability.

DC Characteristics (values in brackets for HYB 3116160BSJ)

$T_A = 0$ to 70 °C, $V_{SS} = 0$ V, $V_{CC} = 3.3$ V \pm 0.3 V, $t_T = 5$ ns

Parameter	Symbol	Limit Values		Unit	Test Condition
		min.	max.		
Input high voltage	V_{IH}	2.0	$V_{CC} + 0.5$	V	1)
Input low voltage	V_{IL}	- 0.5	0.8	V	1)
TTL Output high voltage ($I_{OUT} = - 2$ mA)	V_{OH}	2.4	-	V	1)
TTL Output low voltage ($I_{OUT} = 2$ mA)	V_{OL}	-	0.4	V	1)
CMOS Output high voltage ($I_{OUT} = - 100$ μ A)	V_{OH}	$V_{CC} - 0.2$	-	V	1)
CMOS Output low voltage ($I_{OUT} = 100$ μ A)	V_{OL}	-	0.2	V	1)
Input leakage current, any input ($0 \text{ V} \leq V_{IH} \leq V_{CC} + 0.3 \text{ V}$, all other pins = 0 V)	I_{IL1}	- 10	10	μ A	1)
Output leakage current (DO is disabled, $0 \text{ V} \leq V_{OUT} \leq V_{CC} + 0.3 \text{ V}$)	I_{OIL1}	- 10	10	μ A	1)
Average V_{CC} supply current: -50 ns version -60 ns version -70 ns version (\overline{RAS} , \overline{CAS} , address cycling, $t_{RC} = t_{RC} \text{ min.}$)	I_{CC1}	-	200(100) 180 (90) 160 (80)	mA mA mA	2) 3) 4) 2) 3) 4) 2) 3) 4)
Standby V_{CC} supply current ($\overline{RAS} = \overline{CAS} = V_{IH}$)	I_{CC2}	-	2	mA	-
Average V_{CC} supply current, during \overline{RAS} -only refresh cycles: -50 ns version -60 ns version -70 ns version (\overline{RAS} cycling: $\overline{CAS} = V_{IH}$; $t_{RC} = t_{RC} \text{ min.}$)	I_{CC3}	-	200(100) 180 (90) 160 (80)	mA mA mA	2) 4) 2) 4) 2) 4)

DC Characteristics (values in brackets for HYB 3116160BSJ) (cont'd)

$T_A = 0$ to 70 °C, $V_{SS} = 0$ V, $V_{CC} = 3.3$ V \pm 0.3 V, $t_T = 5$ ns

Parameter	Symbol	Limit Values		Unit	Test Condition
		min.	max.		
Average V_{CC} supply current, during fast page mode: -50 ns version -60 ns version -70 ns version ($\overline{RAS} = V_{IL}$, \overline{CAS} , address cycling, $t_{PC} = t_{PC\ min.}$)	I_{CC4}	–	55 (40) 50 (35) 45 (30)	mA mA mA	2) 3) 4) 2) 3) 4) 2) 3) 4)
Standby V_{CC} supply current ($\overline{RAS} = \overline{CAS} = V_{CC} - 0.2$ V)	I_{CC5}	–	1	mA	1)
Standby V_{CC} supply current (L-version) ($\overline{RAS} = \overline{CAS} = V_{CC} - 0.2$ V)	I_{CC5}	–	200	μ A	1)
Average V_{CC} supply current, during \overline{CAS} -before-RAS refresh mode: -50 ns version -60 ns version -70 ns version (\overline{RAS} , \overline{CAS} cycling, $t_{RC} = t_{RC\ min.}$)	I_{CC6}	– – –	200(100) 180 (90) 160 (80)	mA mA mA	2) 4) 2) 4) 2) 4)
Average Self Refresh Current (CBR cycle with $t_{RAS} > t_{RASS\ min.}$, \overline{CAS} held low, $WE = V_{CC} - 0.2$ V, Address and Din = $V_{CC} - 0.2$ V or 0.2 V)	I_{CC7}	–	1 250	mA μ A	L-version

Capacitance

$T_A = 0$ to 70 °C, $V_{CC} = 3.3$ V \pm 0.3 V, $f = 1$ MHz

Parameter	Symbol	Limit Values		Unit
		min.	max.	
Input capacitance (A0 to A11)	C_{I1}	–	5	pF
Input capacitance (\overline{RAS} , \overline{UCAS} , \overline{LCAS} , \overline{WE} , \overline{OE})	C_{I2}	–	7	pF
I/O capacitance (I/O1-I/O16)	C_{I0}	–	7	pF

AC Characteristics ⁵⁾⁶⁾

$T_A = 0$ to 70 °C, $V_{CC} = 3.3$ V \pm 0.3 V, $t_T = 5$ ns

Parameter	Symbol	Limit Values						Unit	Note
		-50		-60		-70			
		min.	max.	min.	max.	min.	max.		

Common Parameters

Random read or write cycle time	t_{RC}	90	–	110	–	130	–	ns	
RAS precharge time	t_{RP}	30	–	40	–	50	–	ns	
RAS pulse width	t_{RAS}	50	10k	60	10k	70	10k	ns	
CAS pulse width	t_{CAS}	13	10k	15	10k	20	10k	ns	
Row address setup time	t_{ASR}	0	–	0	–	0	–	ns	
Row address hold time	t_{RAH}	8	–	10	–	10	–	ns	
Column address setup time	t_{ASC}	0	–	0	–	0	–	ns	
Column address hold time	t_{CAH}	10	–	15	–	15	–	ns	
RAS to CAS delay time	t_{RCD}	18	37	20	45	20	50		
RAS to column address delay time	t_{RAD}	13	25	15	30	15	35	ns	
RAS hold time	t_{RSH}	13		15	–	20	–	ns	
CAS hold time	t_{CSH}	50		60	–	70	–	ns	
CAS to RAS precharge time	t_{CRP}	5	–	5	–	5	–	ns	
Transition time (rise and fall)	t_T	3	50	3	50	3	50	ns	7
Refresh period for HYB3118160	t_{REF}	–	16	–	16	–	16	ms	
Refresh period for HYB3116160	t_{REF}	–	64	–	64	–	64	ms	
Refresh period for L-versions	t_{REF}	–	256	–	256	–	256	ms	

Read Cycle

Access time from RAS	t_{RAC}	–	50	–	60	–	70	ns	8, 9
Access time from CAS	t_{CAC}	–	13	–	15	–	20	ns	8, 9
Access time from column address	t_{AA}	–	25	–	30	–	35	ns	8,10
OE access time	t_{OEA}	–	13	–	15	–	20	ns	
Column address to RAS lead time	t_{RAL}	25	–	30	–	35	–	ns	
Read command setup time	t_{RCS}	0	–	0	–	0	–	ns	
Read command hold time	t_{RCH}	0	–	0	–	0	–	ns	11

AC Characteristics (cont'd) ⁵⁾⁶⁾

16F

$T_A = 0$ to 70 °C, $V_{CC} = 3.3$ V \pm 0.3 V, $t_T = 5$ ns

Parameter	Symbol	Limit Values						Unit	Note
		-50		-60		-70			
		min.	max.	min.	max.	min.	max.		
Read command hold time referenced to \overline{RAS}	t_{RRH}	0	–	0	–	0	–	ns	11
\overline{CAS} to output in low-Z	t_{CLZ}	0	–	0	–	0	–	ns	8
Output buffer turn-off delay	t_{OFF}	0	13	0	15	0	20	ns	12
Output buffer turn-off delay from OE	t_{OEZ}	0	13	0	15	0	20	ns	12
Data to \overline{OE} low delay	t_{DZO}	0	–	0	–	0	–	ns	13
\overline{CAS} high to data delay	t_{CDD}	13	–	15	–	20	–	ns	14
\overline{OE} high to data delay	t_{ODD}	13	–	15	–	20	–	ns	14

Write Cycle

Write command hold time	t_{WCH}	8	–	10	–	10	–	ns	
Write command pulse width	t_{WP}	8	–	10	–	10	–	ns	
Write command setup time	t_{WCS}	0	–	0	–	0	–	ns	15
Write command to \overline{RAS} lead time	t_{RWL}	13	–	15	–	20	–	ns	
Write command to \overline{CAS} lead time	t_{CWL}	13	–	15	–	20	–	ns	
Data setup time	t_{DS}	0	–	0	–	0	–	ns	16
Data hold time	t_{DH}	10	–	10	–	15	–	ns	16
Data to \overline{CAS} low delay	t_{DZC}	0	–	0	–	0	–	ns	13

Read-Modify-Write Cycle

Read-write cycle time	t_{RWC}	126	–	150	–	180	–	ns	
\overline{RAS} to \overline{WE} delay time	t_{RWD}	68	–	80	–	95	–	ns	15
\overline{CAS} to \overline{WE} delay time	t_{CWD}	31	–	35	–	45	–	ns	15
Column address to \overline{WE} delay time	t_{AWD}	43	–	50	–	60	–	ns	15
\overline{OE} command hold time	t_{OEH}	13	–	15	–	20	–	ns	

Fast Page Mode Cycle

Fast page mode cycle time	t_{PC}	35	–	40	–	45	–	ns	
\overline{CAS} precharge time	t_{CP}	10	–	10	–	10	–	ns	

AC Characteristics (cont'd) ⁵⁾⁶⁾

$T_A = 0$ to 70 °C, $V_{CC} = 3.3$ V \pm 0.3 V, $t_r = 5$ ns

Parameter	Symbol	Limit Values						Unit	Note
		-50		-60		-70			
		min.	max.	min.	max.	min.	max.		
Access time from \overline{CAS} precharge	t_{CPA}	–	30	–	35	–	40	ns	7
\overline{RAS} pulse width	t_{RAS}	50	200k	60	200k	70	200k	ns	
\overline{CAS} precharge to \overline{RAS} Delay	t_{RHPC}	30	–	35	–	40	–	ns	

Fast Page Mode Read-Modify-Write Cycle

Fast page mode read-write cycle time	t_{PRWC}	71	–	80	–	95	–	ns	
\overline{CAS} precharge to \overline{WE}	t_{CPWD}	48	–	55	–	65	–	ns	

\overline{CAS} -before- \overline{RAS} Refresh Cycle

\overline{CAS} setup time	t_{CSR}	10	–	10	–	10	–	ns	
\overline{CAS} hold time	t_{CHR}	10	–	10	–	10	–	ns	
\overline{RAS} to \overline{CAS} precharge time	t_{RPC}	5	–	5	–	5	–	ns	
Write to \overline{RAS} precharge time	t_{WRP}	10	–	10	–	10	–	ns	
Write hold time referenced to \overline{RAS}	t_{WRH}	10	–	10	–	10	–	ns	

\overline{CAS} -before- \overline{RAS} Counter Test Cycle

\overline{CAS} precharge time	t_{CPT}	35	–	40	–	40	–	ns	
---------------------------------	-----------	----	---	----	---	----	---	----	--

Self Refresh Cycle

\overline{RAS} pulse width	t_{RASS}	100k	–	100k	–	100k	–	ns	17
\overline{RAS} precharge time	t_{RPS}	95	–	110	–	130	–	ns	17
\overline{CAS} hold time	t_{CHS}	– 50	–	– 50	–	– 50	–	ns	17

Notes:

- 1) All voltages are referenced to V_{SS} .
- 2) I_{CC1} , I_{CC3} , I_{CC4} and I_{CC6} depend on cycle rate.
- 3) I_{CC1} and I_{CC4} depend on output loading. Specified values are measured with the output open.
- 4) Address can be changed once or less while $\overline{RAS} = V_{IL}$. In the case of I_{CC4} it can be changed once or less during a fast page mode cycle (t_{PC}).
- 5) An initial pause of 200 μs is required after power-up followed by 8 \overline{RAS} cycles of which at least one cycle has to be a refresh cycle, before proper device operation is achieved. In case of using internal refresh counter, a minimum of 8 CAS-before-RAS initialization cycles instead of 8 RAS cycles are required.
- 6) AC measurements assume $t_T = 5$ ns.
- 7) $V_{IH (min.)}$ and $V_{IL (max.)}$ are reference levels for measuring timing of input signals. Transition times are also measured between V_{IH} and V_{IL} .
- 8) Measured with a load equivalent to 100 pF and at $V_{OH} = 2.0$ V ($I_{OH} = -2$ mA), $V_{OL} = 0.8$ V ($I_{OL} = 2$ mA).
- 9) Operation within the $t_{RCD (max.)}$ limit ensures that $t_{RAC (max.)}$ can be met. $t_{RCD (max.)}$ is specified as a reference point only: If t_{RCD} is greater than the specified $t_{RCD (max.)}$ limit, then access time is controlled by t_{CAC} .
- 10) Operation within the $t_{RAD (max.)}$ limit ensures that $t_{RAC (max.)}$ can be met. $t_{RAD (max.)}$ is specified as a reference point only: If t_{RAD} is greater than the specified $t_{RAD (max.)}$ limit, then access time is controlled by t_{AA} .
- 11) Either t_{RCH} or t_{RRH} must be satisfied for a read cycle.
- 12) $t_{OFF (max.)}$ and $t_{OEZ (max.)}$ define the time at which the outputs achieve the open-circuit condition and are not referenced to output voltage levels.
- 13) Either t_{DZC} or t_{DZO} must be satisfied.
- 14) Either t_{CDD} or t_{ODD} must be satisfied.
- 15) t_{WCS} , t_{RWD} , t_{CWD} , t_{AWD} and t_{CPWD} are not restrictive operating parameters. They are included in the data sheet as electrical characteristics only. If $t_{WCS} > t_{WCS (min.)}$, the cycle is an early write cycle and the I/O pin will remain open-circuit (high impedance) through the entire cycle; if $t_{RWD} > t_{RWD (min.)}$, $t_{CWD} > t_{CWD (min.)}$, $t_{AWD} > t_{AWD (min.)}$ and $t_{CPWD} > t_{CPWD (min.)}$, the cycle is a read-write cycle and I/O pins will contain data read from the selected cells. If neither of the above sets of conditions is satisfied, the condition of the I/O pins (at access time) is indeterminate.
- 16) These parameters are referenced to the \overline{CAS} leading edge in early write cycles and to the \overline{WE} leading edge in read-write cycles.
- 17) When using Self Refresh mode, the following refresh operations must be performed to ensure proper DRAM operation:

If row addresses are being refreshed on an evenly distributed manner over the refresh interval using CBR refresh cycles, then only one CBR cycle must be performed immediately after exit from Self Refresh.

If row addresses are being refreshed in any other manner (ROR - Distributed/Burst; or CBR-Burst) over the refresh interval, then a full set of row refreshes must be performed immediately before entry to and immediately after exit from Self Refresh.

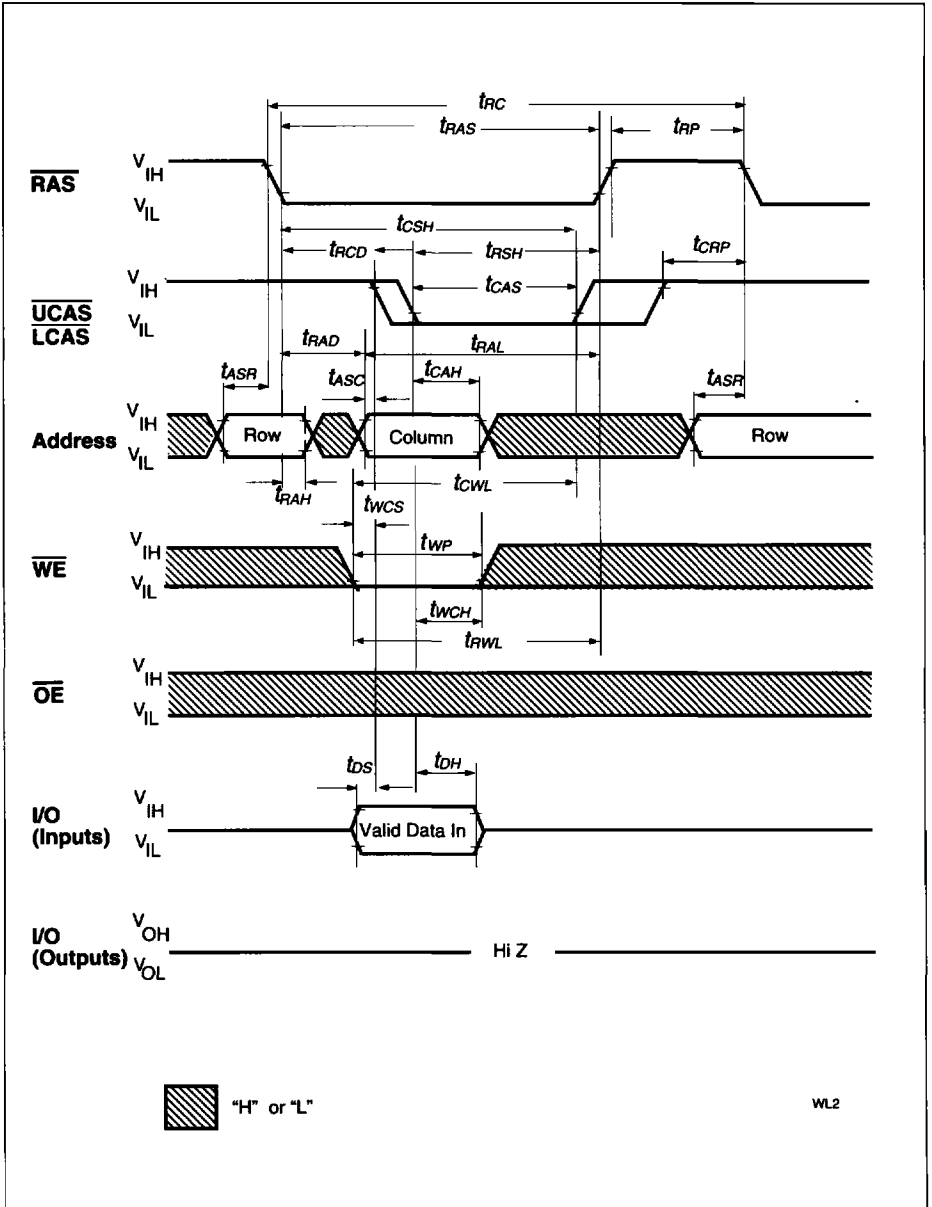

Write Cycle (Early Write)

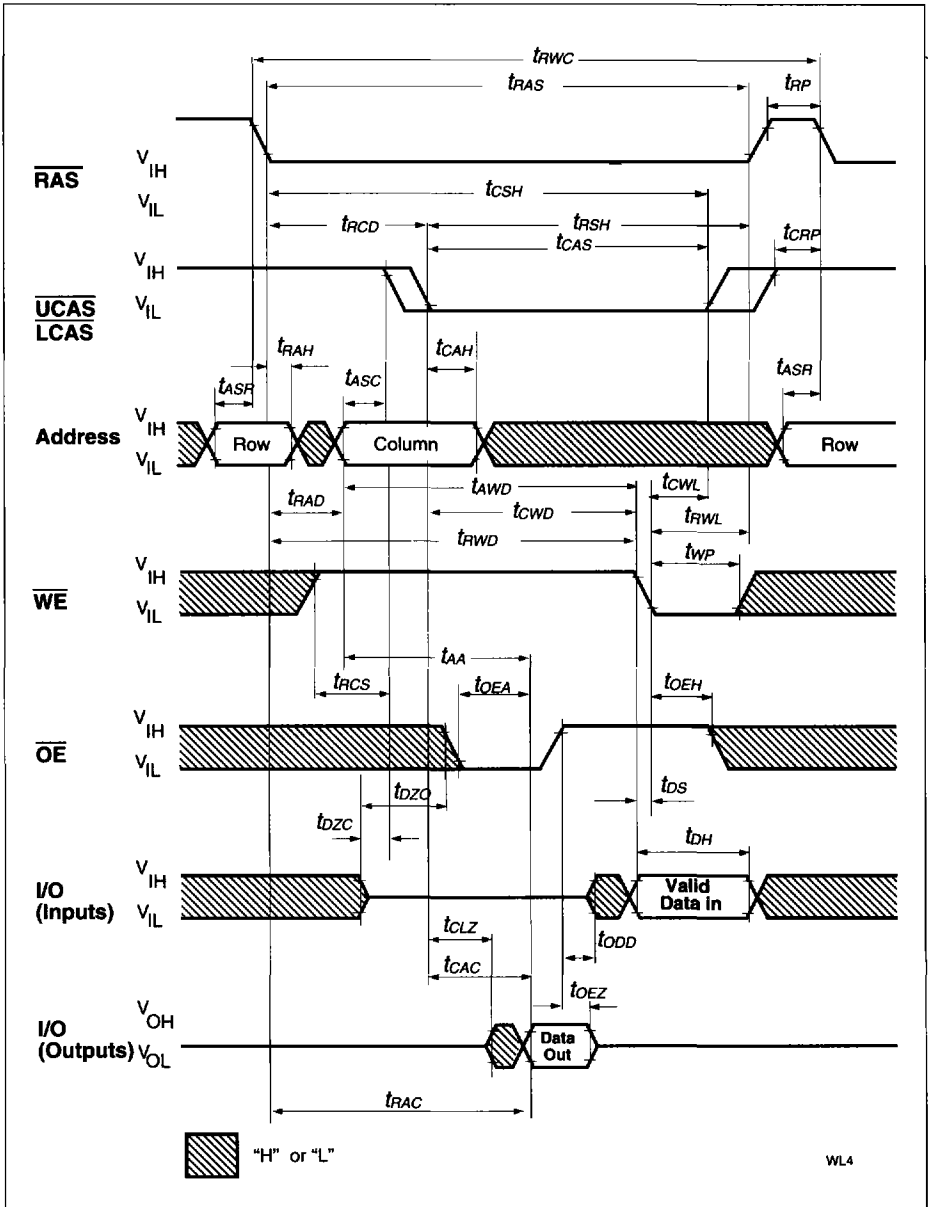

Read-Write (Read-Modify-Write) Cycle

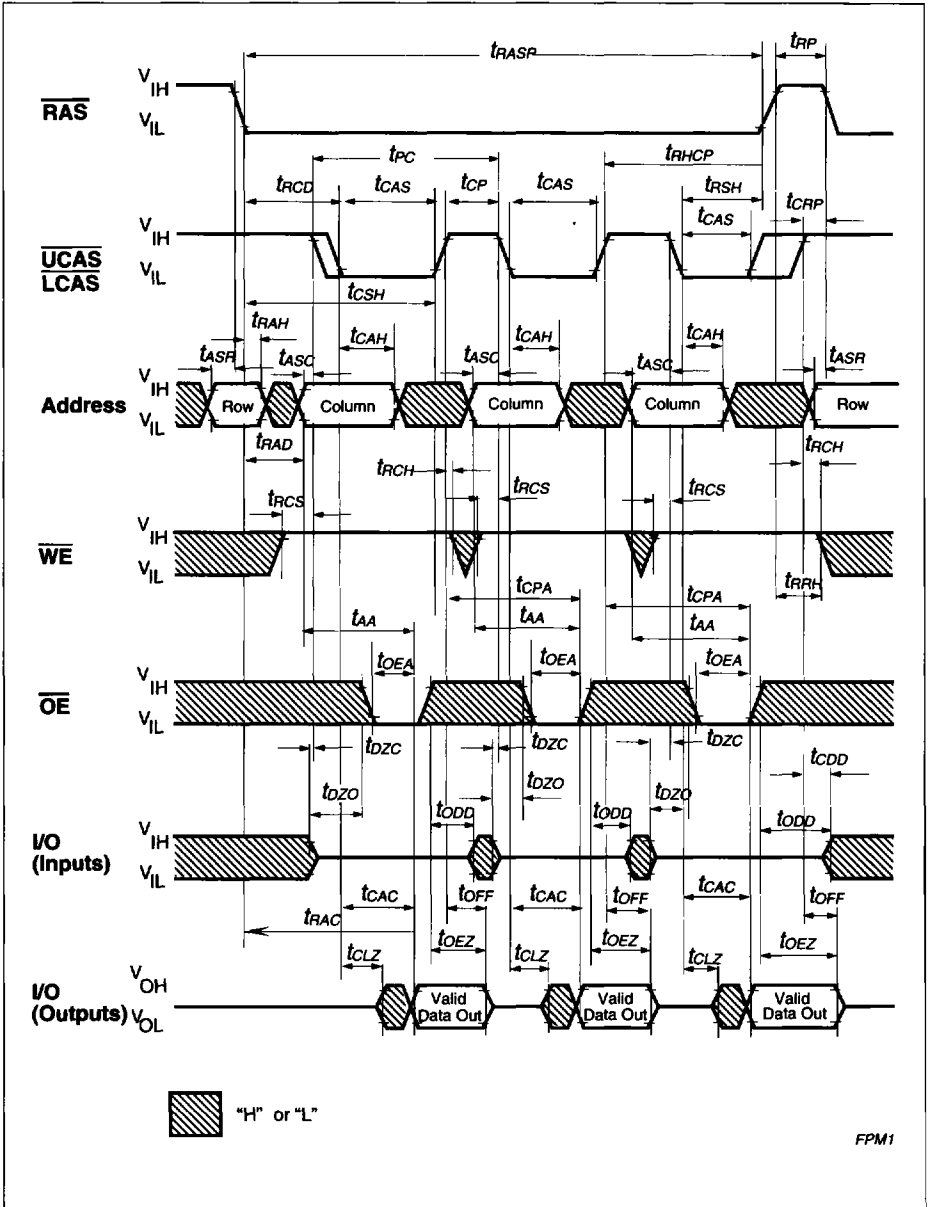

Fast Page Mode Read Cycle

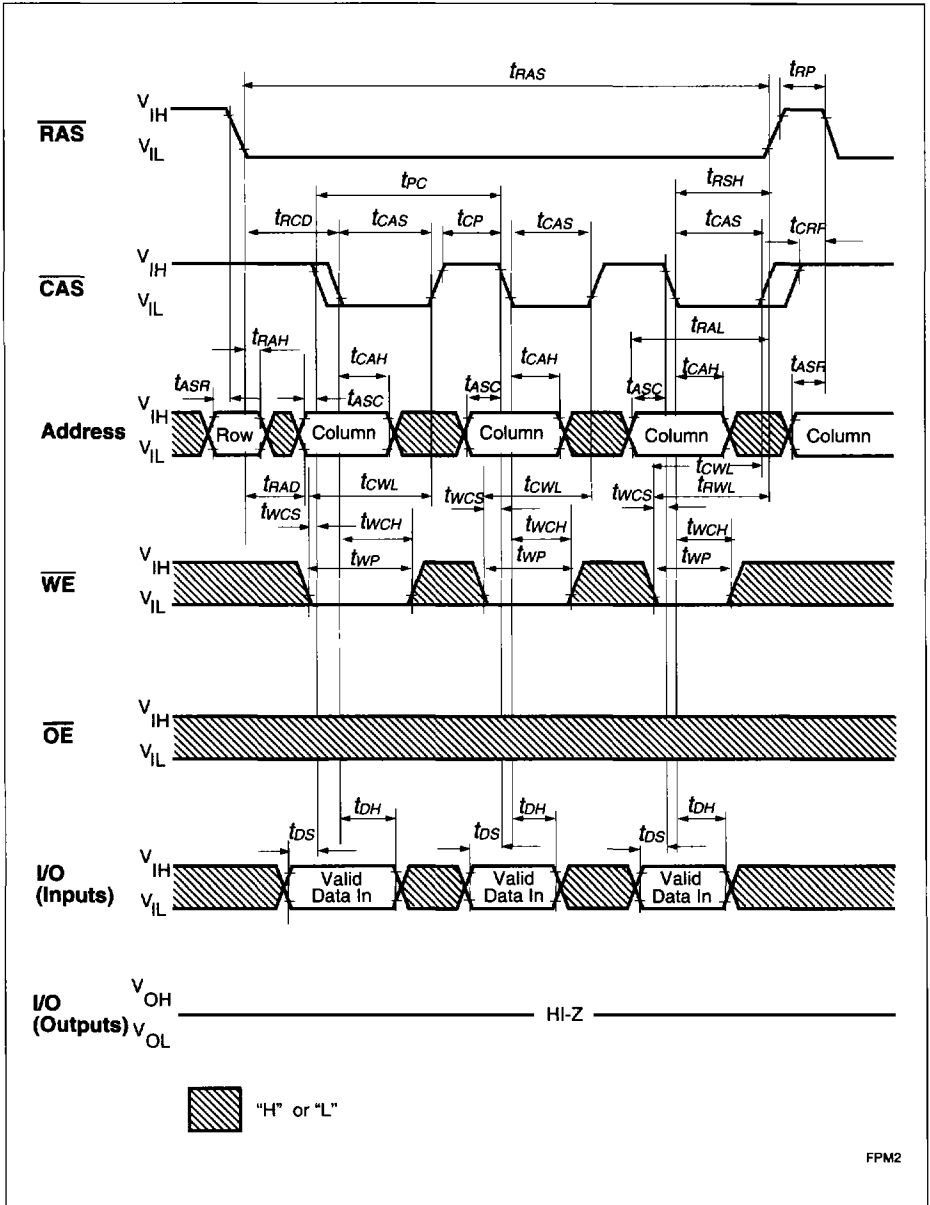

Fast Page Mode Early Write Cycle

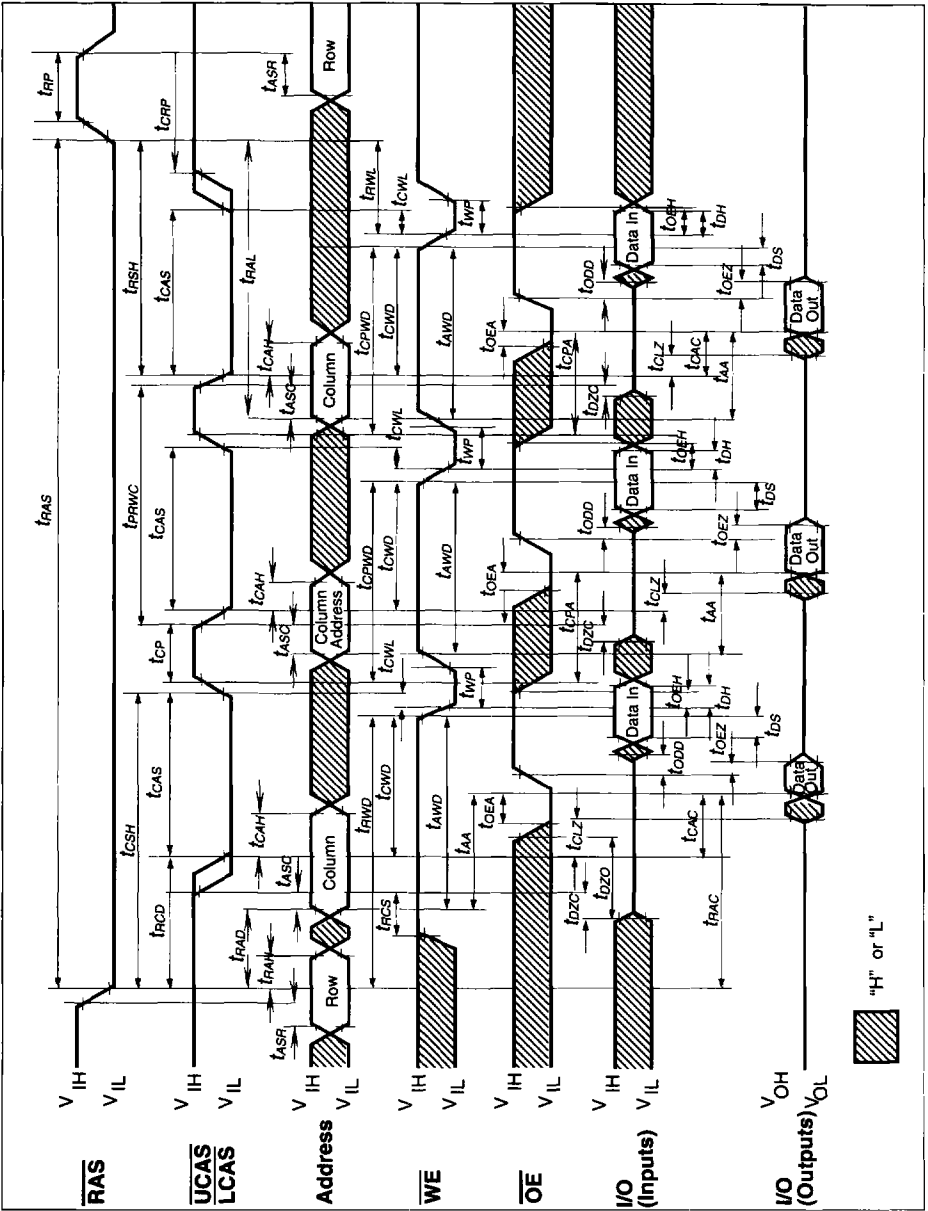

Fast Page Mode Read-Modify- Write Cycle

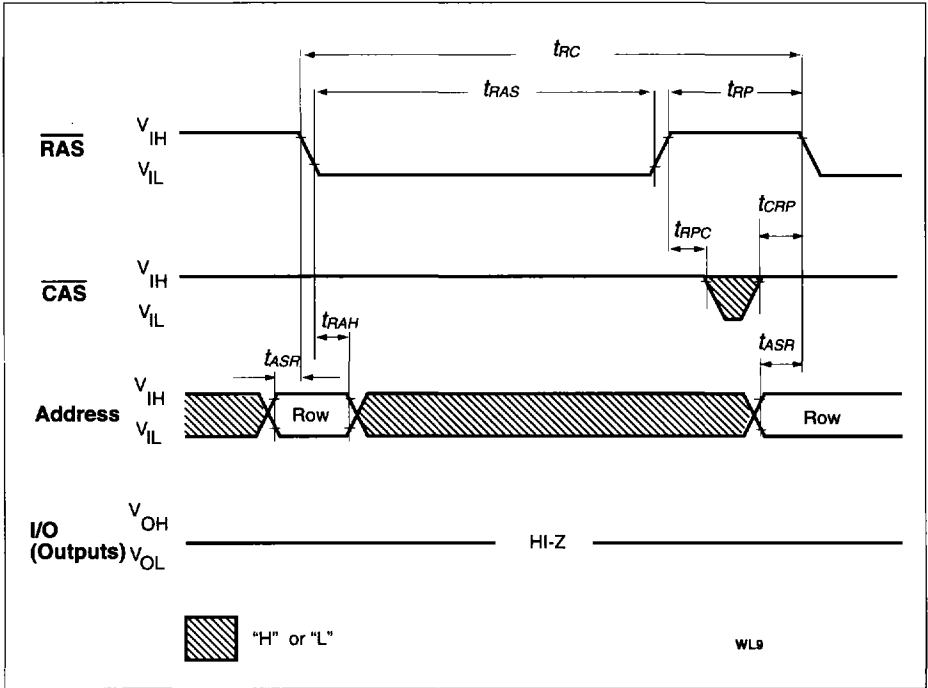

RAS-Only Refresh Cycle

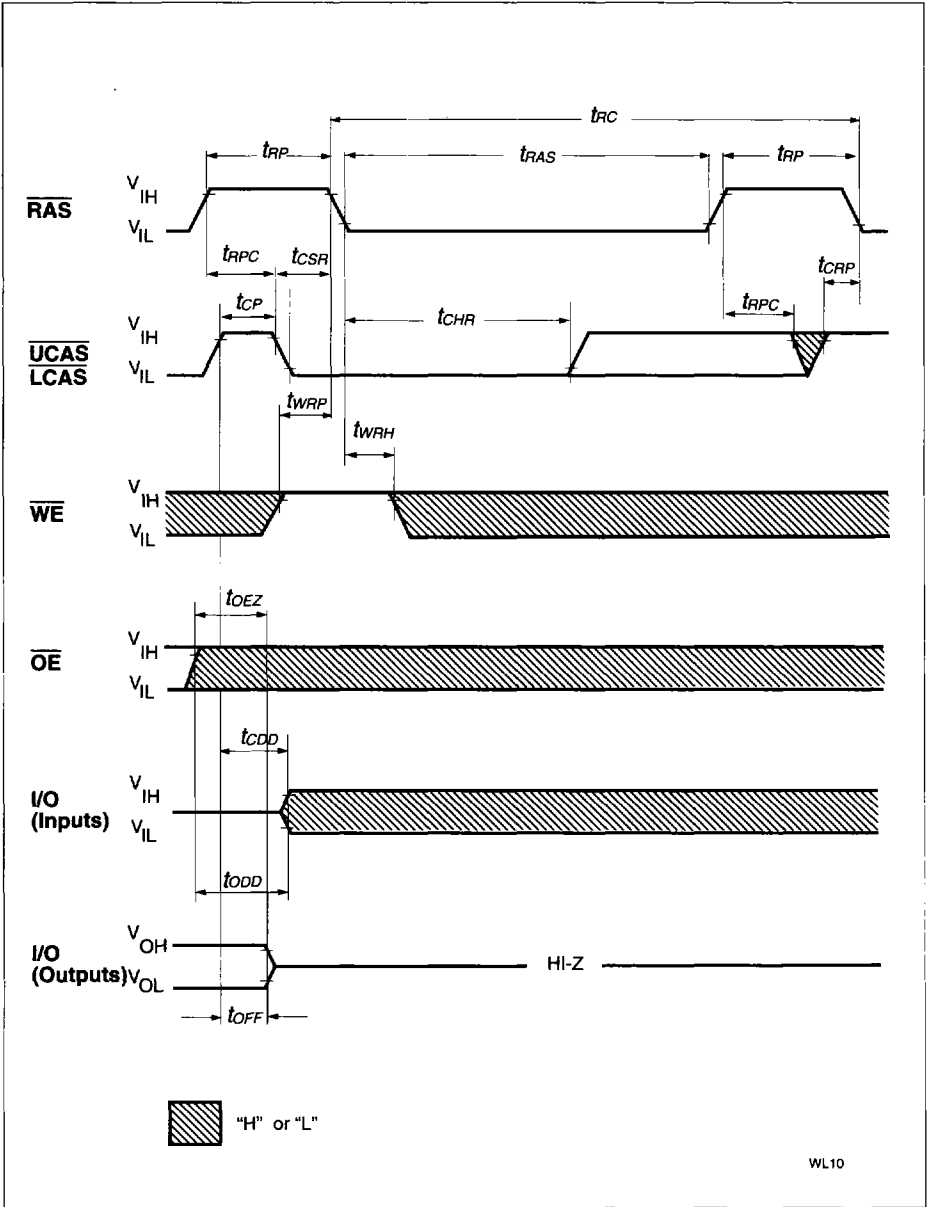

CAS-Before-RAS Refresh Cycle

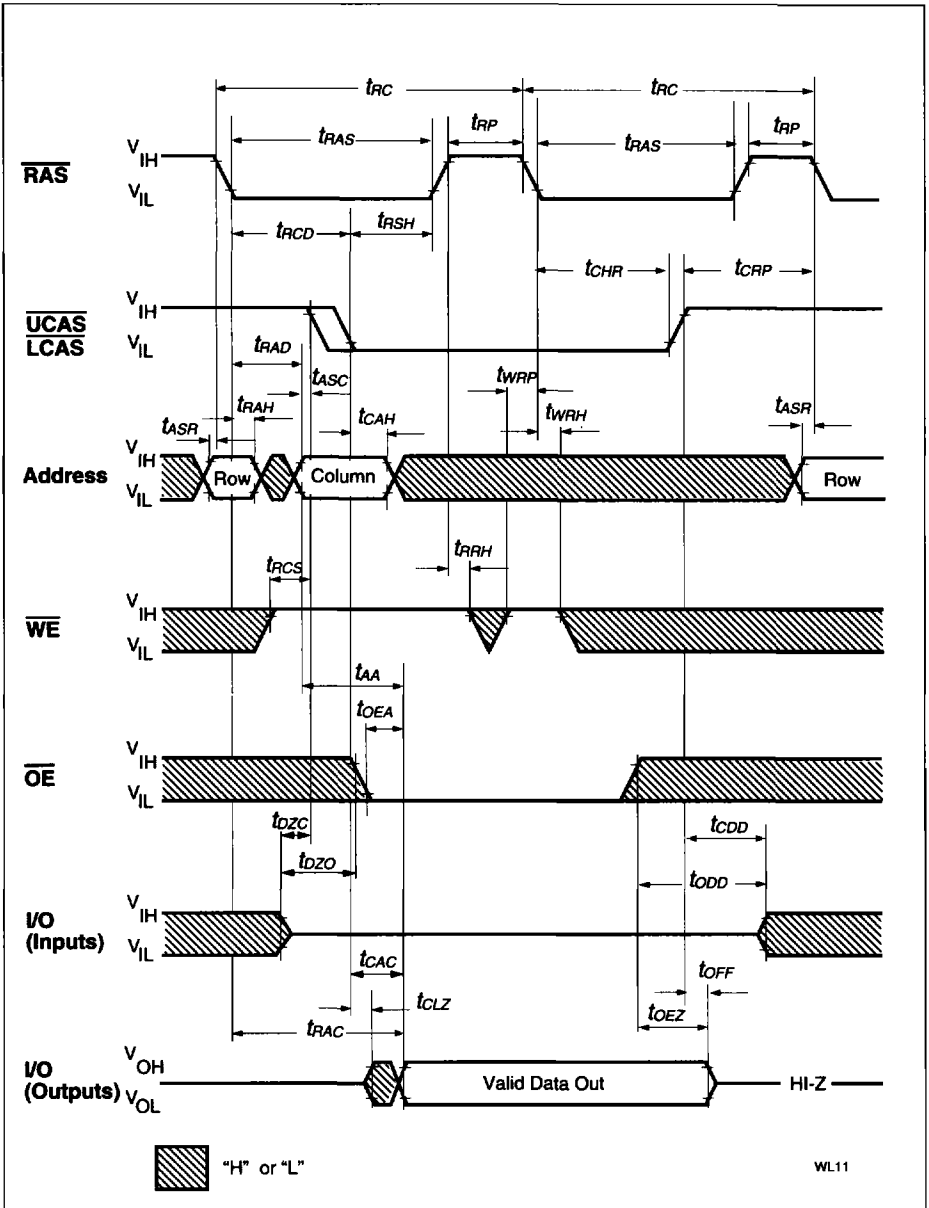

Hidden Refresh Cycle (Read)

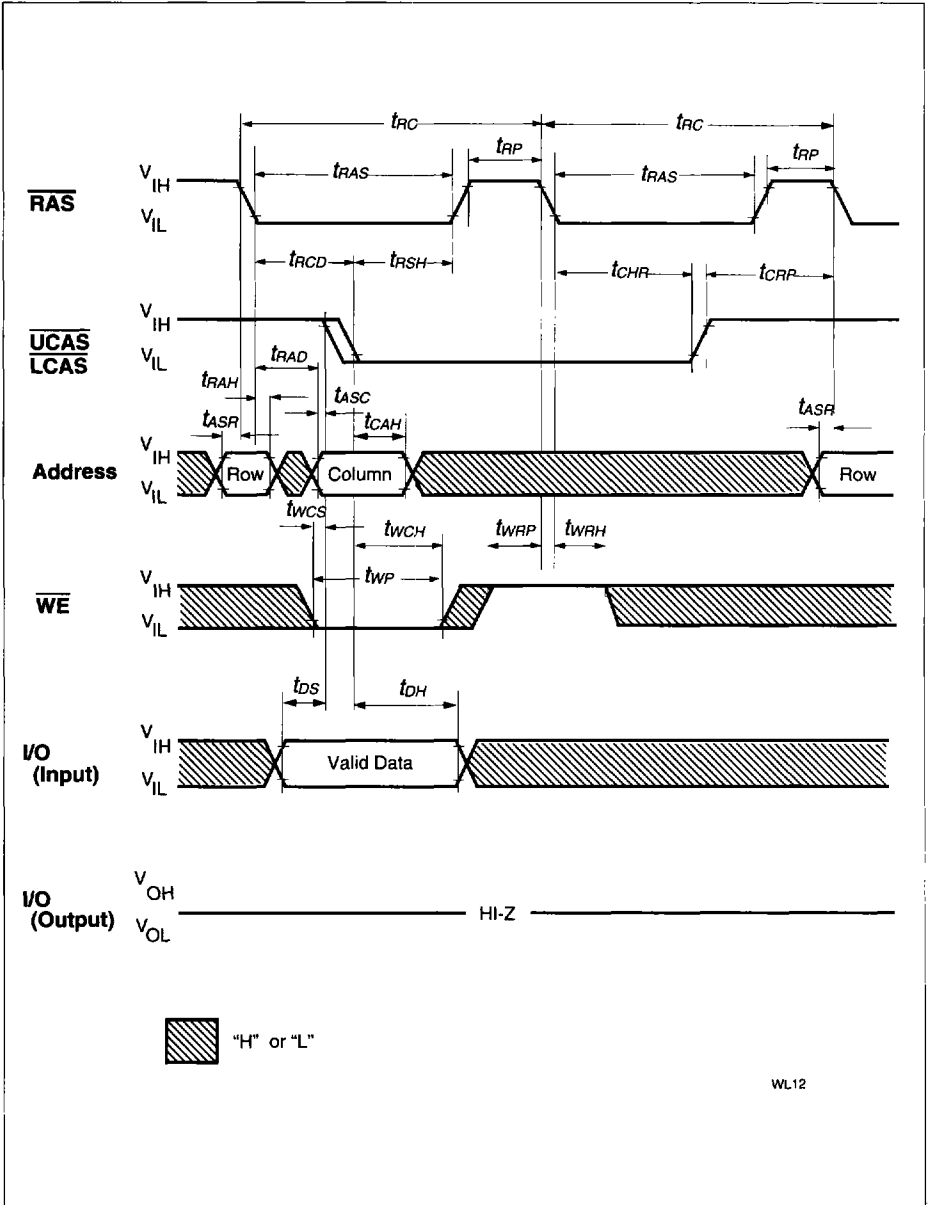

Hidden Refresh Cycle (Early Write)

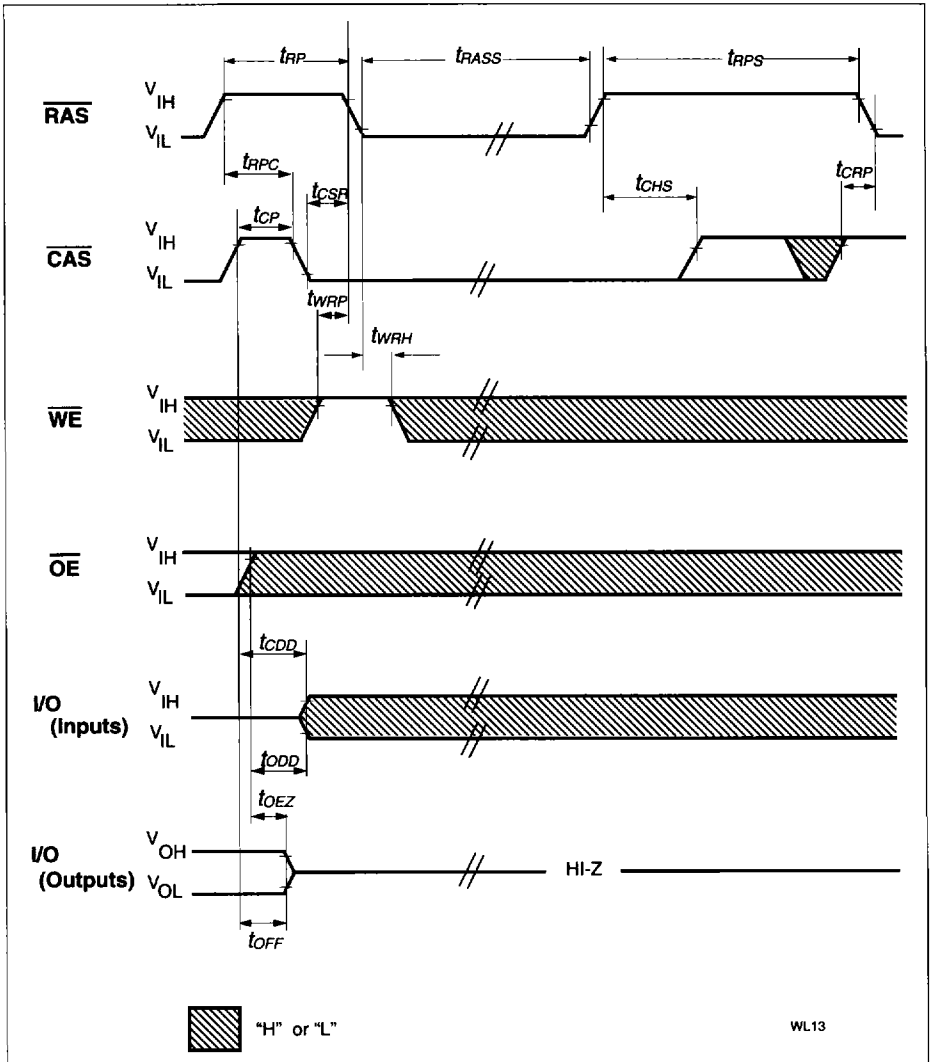

CAS before RAS Self Refresh Cycle

Package Outlines

P-SOJ-42 (400 mil)
(Plastic Small Outline J-led Package)

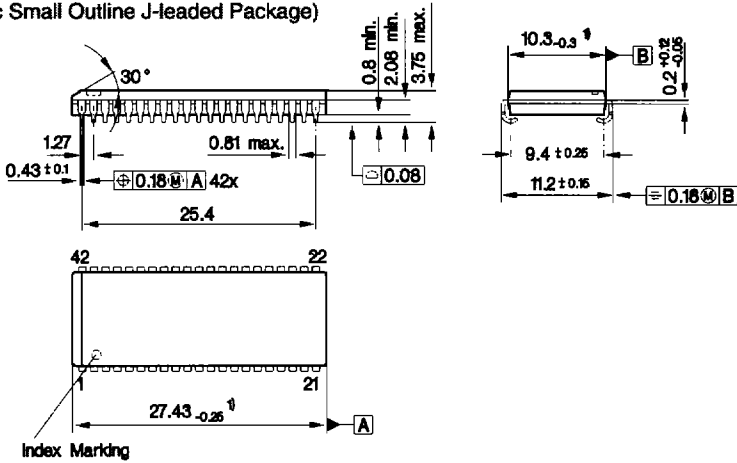

1) Does not include plastic or metal protrusion of 0.25 max. per side

GPJ05853

P-TSOPII-50/44 (400 mil)
(Thin Small Outline, 0.8 mm lead pitch)

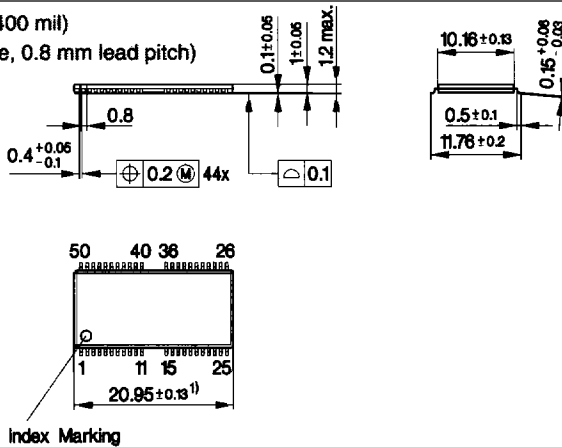

1) Does not include plastic or metal protrusion of 0.25 max. per side

GPX05860

Sorts of Packing

Package outlines for tubes, trays etc. are contained in our Data Book "Package Information".

SMD = Surface Mounted Device

Dimensions in mm