

Series 802 Receptacles



Jam Nut, Rear Mount



Square Flange

Immersion Rated to 3500 PSI. A piston o-ring provides sealing to the mating plug.

316 Series **Stainless Steel** shells offer maximum resistance to mechanical and environmental abuse.

Three Shell Mounting Options:
Jam nut with o-ring for rear panel mounting, square flange for front

panel mounting, or in-line receptacles for free-hanging cables.

Two Shell Styles: Choose the integral band platform for direct attachment of a cable shield. Install a boot, or overmold a boot over the band platform. An accessory thread is available for attaching strain reliefs and backshells.

HOW TO ORDER SERIES 802 CRIMP RECEPTACLES

Sample Part Number					
802-011	-02	ZM	10-26	P	B
Series	Shell Style	Shell Material / Finish	Shell Size- Insert Arrangement	Contact Type	Shell Key Position
<p>802-010 Receptacle with Banding Platform</p>	<p>-01 In-Line</p>	<p>Z1 Stainless Steel / Passivated</p> <p>ZM Stainless Steel / Electroless Nickel Plated</p>	<p>5-3 3 #23 Contacts 6-1 1 #16 Contact 6-4 4 #23 Contacts 6-7 7 #23 Contacts 7-1 1 #12 Contact 7-10 10 #23 Contacts 8-13 13 #23 Contacts 9-4 4 #16 Contacts 9-19 19 #23 Contacts 10-26 26 #23 Contacts 12-2 2 #12 Contacts 12-37 37 #23 Contacts 14-55 55 #23 Contacts 15-85 85 #23 Contacts</p> <p>#23 contacts are packaged with connectors. #16 and #12 contacts must be ordered separately.</p>	<p>P Pin</p> <p>S Socket</p> <p>Standard #23 contacts accept #22 through #28 AWG wire. Special contacts for #26 to #30 AWG are available. Use the following contact codes to specify these contacts:</p> <p>G Pin #2630</p> <p>H Socket #2630</p>	<p>A Normal</p> <p>B Pos. B</p> <p>C Pos. C</p> <p>D Pos. D</p>
<p>802-011 Receptacle with Accessory Thread</p>	<p>-02 Square Flange</p> <p>-07 Jam Nut for Rear Panel Mounting</p>				

Series 802 Jam Nut Receptacles

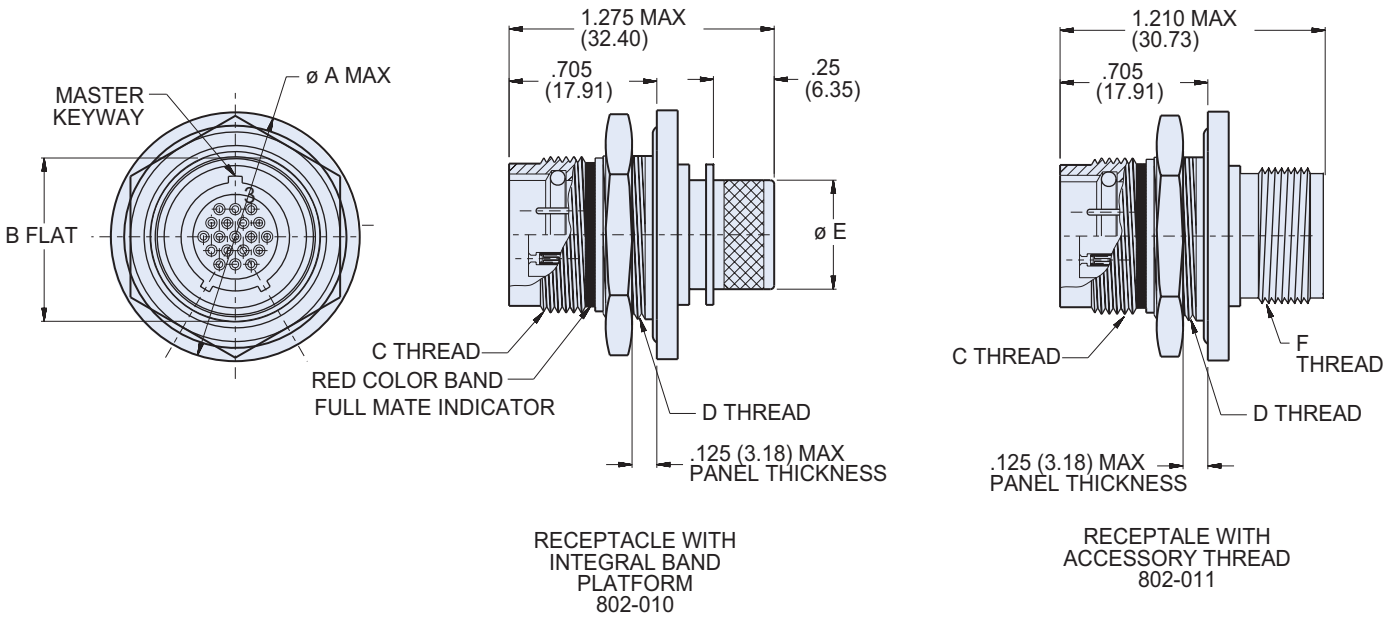

DIMENSIONS

Shell Size	A Max.		B Flat		C Mating Threads	D Jam Nut Threads	Ø E		F Accessory Threads	G Flat		Ø H	
	In.	mm.	In. ±.003	mm. ±0.08			In.	mm.		In. ±.003	mm. ±0.08	In.	mm.
5	.885	22.48	.466	11.84	.438-28 UNEF	.500-32 UN-2A	.250	6.35	.2500-32 UNEF-2A	.477	12.12	.510	12.95
6	1.010	25.65	.591	15.01	.562-20 UN	.625-28 UN-2A	.312	7.92	.3125-32 UNEF-2A	.602	15.29	.635	16.13
7	1.072	27.23	.653	16.59	.625-20 UN	.687-28 UN-2A	.375	9.53	.4375-28 UNEF-2A	.664	16.87	.697	17.70
8	1.135	28.83	.716	18.19	.687-20 UN	.750-28 UN-2A	.438	11.13	.5000-28 UNEF-2A	.727	18.47	.760	19.30
9	1.195	30.35	.778	19.76	.750-20 UNEF	.812-28 UN-2A	.500	12.70	.5625-24 UNEF-2A	.789	20.04	.822	20.88
10	1.260	32.00	.827	21.01	.812-20 UNEF	.875-28 UN-2A	.562	14.27	.6250-24 UNEF-2A	.838	21.29	.885	22.48
12	1.322	33.58	.890	22.61	.875-20 UNEF	.938-28 UN-2A	.656	16.66	.6875-24 UNEF-2A	.901	22.89	.948	24.08
14	1.510	38.25	1.077	27.36	1.062-20 UN	1.125-28 UN-2A	.812	20.62	.8750-20 UNEF-2A	1.088	27.64	1.135	28.83
15	1.572	39.93	1.140	28.96	1.125-20 UN	1.188-28 UN-2A	.875	22.23	.9375-20 UNEF-2A	1.151	29.24	1.198	30.43

SERIES 802 RECEPTACLE KEY POSITIONS

Key Position	Key Rotation	
	A°	B°
Normal (A)	150°	210°
B	75°	210°
C	95°	230°
D	140°	275°

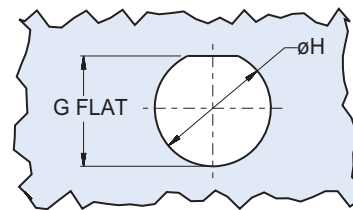

RECOMMENDED PANEL CUTOUT

Series 802 Square Flange Receptacles

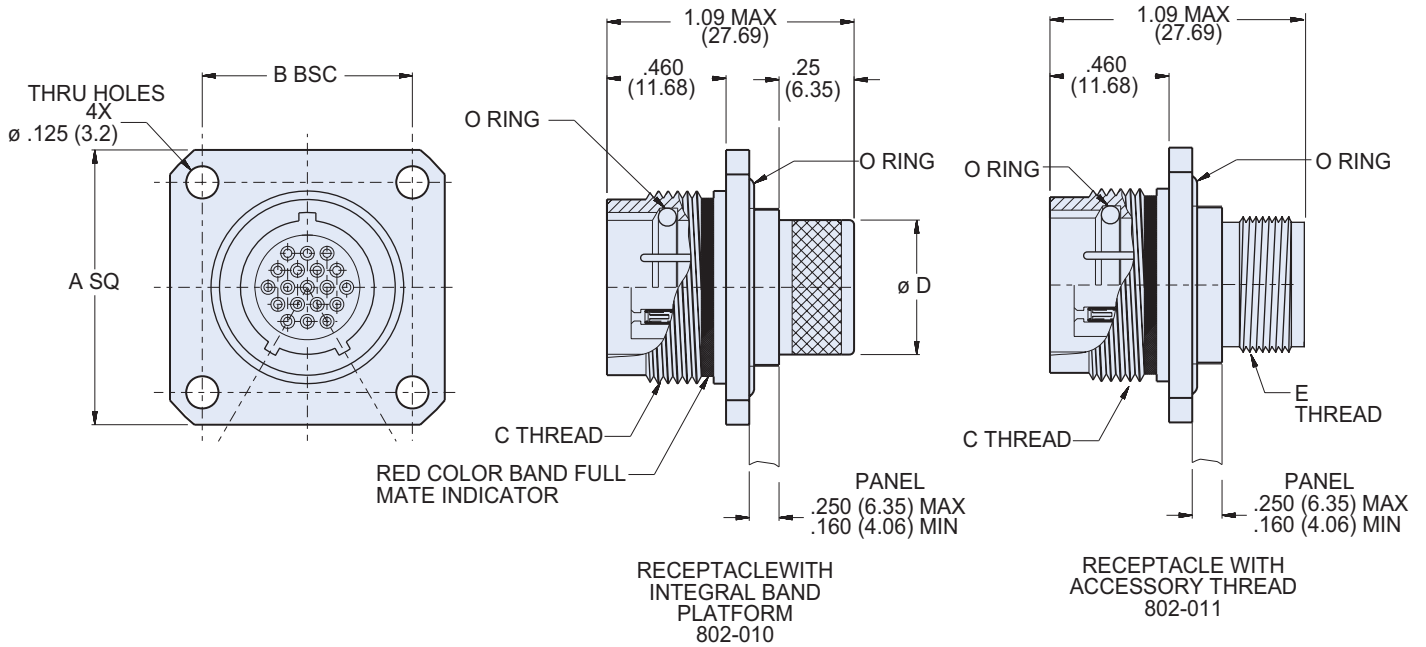

DIMENSIONS

Shell Size	A Square		B Bsc.		C Mating Threads	ø D		E Threads Accessory	ø F	
	In.	mm.	In.	mm.		In.	mm.		In.	mm.
5	.885	22.48	.500	12.70	.438-28 UNEF	.250	6.35	.2500-32 UNEF-2A	.327	8.31
6	1.010	25.65	.625	15.88	.562-20 UN	.312	7.92	.3125-32 UNEF-2A	.390	9.91
7	1.072	27.23	.688	17.48	.625-20 UN	.375	9.53	.4375-28 UNEF-2A	.515	13.08
8	1.135	28.83	.750	19.05	.687-20 UN	.438	11.13	.5000-28 UNEF-2A	.577	14.66
9	1.195	30.35	.812	20.62	.750-20 UNEF	.500	12.70	.5625-24 UNEF-2A	.640	16.26
10	1.260	32.00	.875	22.23	.812-20 UNEF	.562	14.27	.6250-24 UNEF-2A	.702	17.83
12	1.322	33.58	.938	23.83	.875-20 UNEF	.656	16.66	.6875-24 UNEF-2A	.765	19.43
14	1.510	38.25	1.125	28.58	1.062-20 UN	.812	20.62	.8750-20 UNEF-2A	.953	24.21
15	1.572	39.93	1.188	30.18	1.125-20 UN	.875	22.23	.9375-20 UNEF-2A	1.015	25.78

SERIES 802 RECEPTACLE KEY POSITIONS

Key Position	Key Rotation	
	A°	B°
Normal (A)	150°	210°
B	75°	210°
C	95°	230°
D	140°	275°

SERIES 802 SQ FLANGE PANEL CUTOUT

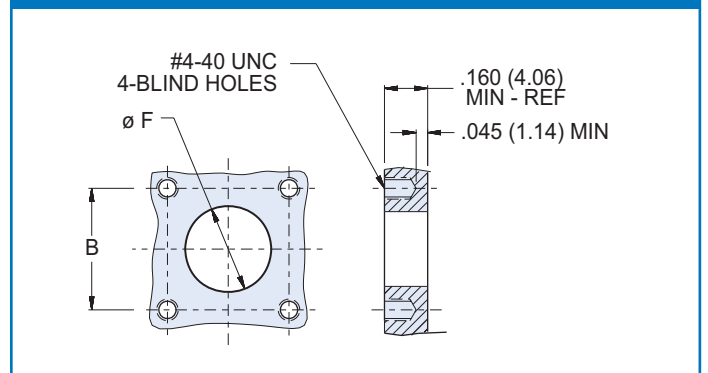

Series 802 In-Line Receptacles

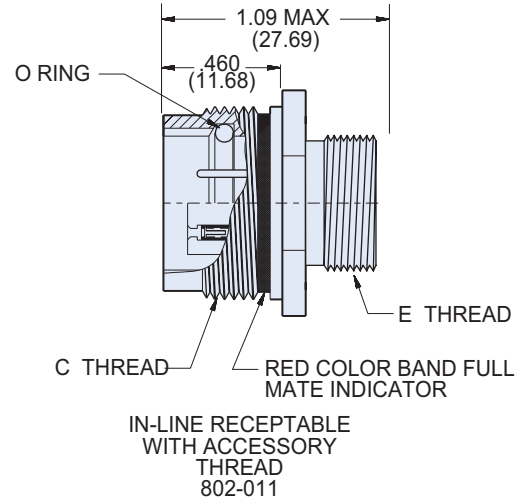
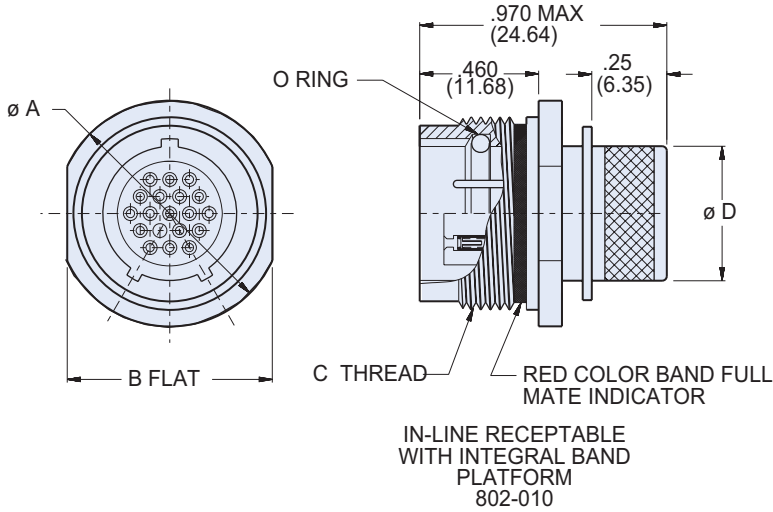

DIMENSIONS

Shell Size	Ø A		B Flat		C Mating Threads	Ø D		E Threads Accessory
	In.	mm.	In.	mm.		In.	mm.	
5	.560	14.22	.500	12.70	.438-28 UNEF	.250	6.35	.2500-32 UNEF-2A
6	.720	18.29	.625	15.88	.562-20 UN	.312	7.92	.3125-32 UNEF-2A
7	.780	19.81	.688	17.48	.625-20 UN	.375	9.53	.4375-28 UNEF-2A
8	.860	21.84	.750	19.05	.687-20 UN	.438	11.13	.5000-28 UNEF-2A
9	.930	23.62	.812	20.62	.750-20 UNEF	.500	12.70	.5625-24 UNEF-2A
10	1.000	25.40	.875	22.23	.812-20 UNEF	.562	14.27	.6250-24 UNEF-2A
12	1.060	26.92	.938	23.83	.875-20 UNEF	.656	16.66	.6875-24 UNEF-2A
14	1.250	31.75	1.125	28.58	1.062-20 UN	.812	20.62	.8750-20 UNEF-2A
15	1.320	33.53	1.188	30.18	1.125-20 UN	.875	22.23	.9375-20 UNEF-2A

SERIES 802 RECEPTACLE KEY POSITIONS

Key Position	Key Rotation	
	A°	B°
Normal (A)	150°	210°
B	75°	210°
C	95°	230°
D	140°	275°