

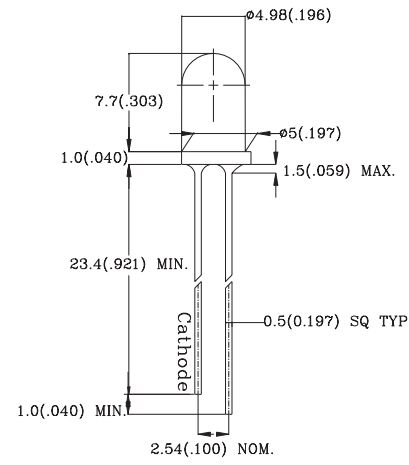

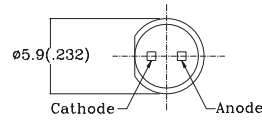

Infrared Emitting Diode End Look

Part Number	Chip		Lens Color	V _F (V) @ I _F =50mA		E _e (mW/cm ²) @ I _F =50mA		Viewing Angle 2θ 1/2
	Material	Wavelength λ p		Typ.	Max.	Min.	Typ.	



BIR-BM18V4V-2	GaAlAs/GaAs	940	Blue Transparent	1.25	1.50	1.20	2.00	60
BIR-BO18V4V-2	GaAlAs/GaAlAs	850		1.50	1.80	1.30	2.90	
BIR-BO08V4V-2	GaAlAs/GaAlAs	850		1.50	1.80	1.30	2.90	
BIR-BN08V4V-2	GaAlAs/GaAlAs	880		1.30	1.70	1.30	2.90	

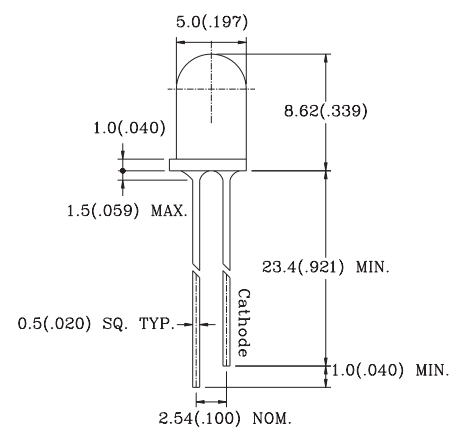
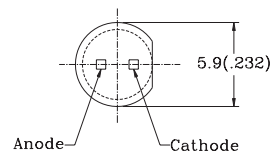

BIR-BM18E4G-2	GaAlAs/GaAs	940	Blue Transparent	1.25	1.50	1.50	2.80	40
BIR-BO18E4G-2	GaAlAs/GaAlAs	850		1.50	1.80	2.10	3.70	
BIR-BO08E4G-2	GaAlAs/GaAlAs	850		1.50	1.80	2.10	3.70	
BIR-BN08E4G-2	GaAlAs/GaAlAs	880		1.30	1.70	2.10	3.70	