



The HS45 Dual Output Encoder

The HS45 is a large bore, heavy duty, rugged encoder designed to operate in very demanding environments. It is available in both single and dual output versions as shown above. These encoders use a preloaded bearing set for mechanical stability and a long service life.

The dual output version has redundant electronics internal to the encoder simplifying signal distribution to multiple controllers.

The HS45 Incremental Encoder is available with the following certifications:

EN 55011 and EN 61000-6-2

CENELEC EEX ia IIC T4

U.S. Standards Class I, Group A,B,C & D; Class II Group E,F & G

Canadian Standards Class I, Zone 0, Group IIC

Mechanical Specifications

Shaft Bore: 1.750" max

Allowable Misalignment: Axial: ± 0.030 (with R2), ± 0.050 (with R1), Radial: 0.005 T.I.R.

Bore Runout: 0.002" T.I.R.

Running Torque at 25° C: Dual seals (SS) = 30 in-oz (max); Single seal (BS) = 18 in-oz (max)

Bearings: 52100 dual preloaded bearings

Shaft Material: Stainless Steel

Bearing Housing: Die cast aluminum with protective finish

Cover: Die cast aluminum with protective finish

Bearing Life: 5×10^{12} revs

Maximum RPM: 5,000 RPM (see Frequency Response, below)

Moment of Inertia: 0.063 oz-in-sec² max

Weight: Approximately 2.3 lbs single output, 2.6 lbs dual output

Electrical Specifications

Code: Incremental

Output Format: Incremental output format, 2 channels with complements, in quadrature, 1/2 cycle index gated with negative B channel

Cycles per Shaft Turn: Up to 8192

Supply Voltage: 5–28 VDC ($\pm 5\%$)

Current Requirements: 100 mA (typical) per side + output load, 250 mA (max)

Voltage/Output: (see note 5)

28V/V: Line Driver, 5–28 VDC in, $V_{out} = V_{in}$

28V/5: Line Driver, 5–28 VDC in, $V_{out} = 5$ VDC

28V/OC: Open Collector, 5–28 VDC in, OCout

Protection Level: Reverse, overvoltage and output short circuit (see note 5)

Frequency Response: 150kHz

Output Terminations: see Table 1

Environmental Specifications

Enclosure Rating: IP65 (NEMA 4 & 13)

Temperature: Operating 0° to 70°C standard, -40° to 85° C optional, storage -40 to 90° C

Shock: 50 g's for 11 msec

Vibration: 10–2000 Hz @ 20 g's

Humidity: 98% RH non-condensing

NOTES & TABLES: All notes and tables referred to in the text can be found on the back page.

HS45 Incremental Ordering Options FOR ASSISTANCE CALL 800-350-2727

Use this diagram, working from left to right to construct your model number (example: HS45F-175-R2-SS-8192-ABZC-28V/V-SM18).

All notes and tables referred to can be found on the back of this page.

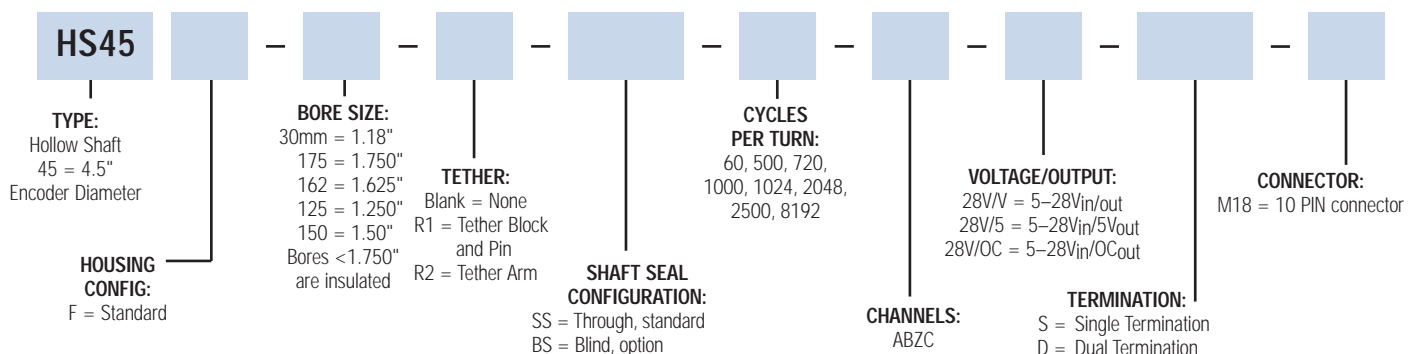

Dimensions

MS Connector Termination

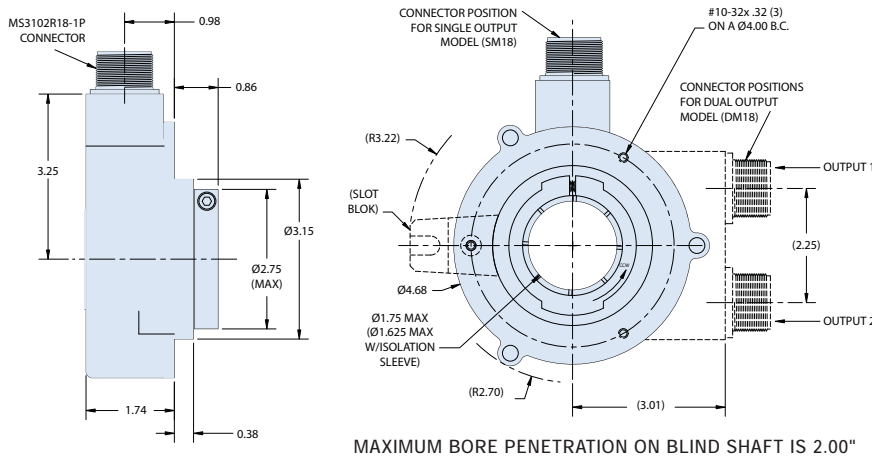

R1 Tether Block and Pin

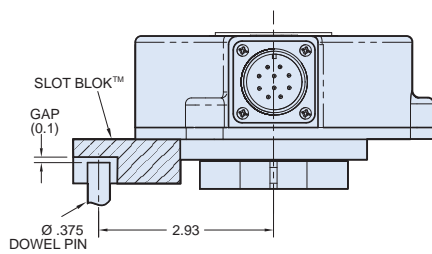

R2 Tether Arm (Fits Ø 7.25 [184] B.C.)

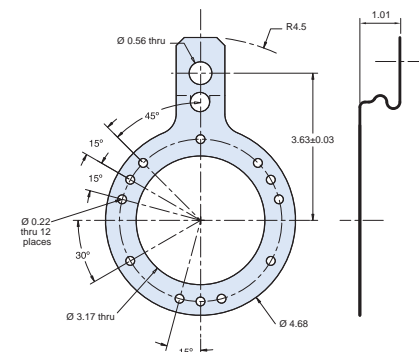

Table 1 Incremental Output Terminations

The connector style will determine pinouts. For example, an encoder with ABC channels and an M18 connector uses the table to the right.

WIRE COLOR (22AWG)	DA 15P CONNECTOR	CHANNELS DESIGNATED IN MODEL NO.		
		ABZ	ABC	ABZC
YEL	13	A	A	A
BLUE	14	B	B	B
ORN	15	Z	—	Z
W-Yel	10	—	A̅	A̅
W-Blu	11	—	B̅	B̅
W-Orn	12	—	—	Z̅
RED	6	+V (SUPPLY VOLTAGE)		
BLK	1	0 V (CIRCUIT COMMON)		
GRN	9	CASE GROUND (CG) (except H20)		
WHITE		SHIELD DRAIN (Shielded Cable Only)		

M18 CONNECTOR	
PIN	CHANNEL
A	A
B	B
C	Z
D	+V
E	—
F	0V
G	CG
H	A̅
I	B̅
J	Z̅

Figure 1 Output Waveform

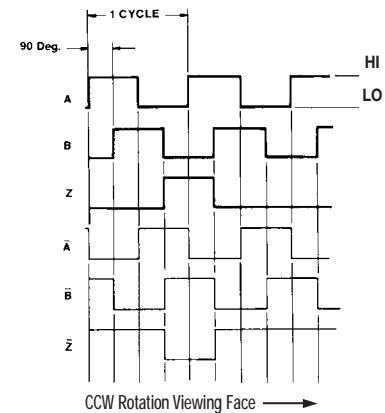

Notes

- Mounting is usually done either using the D-style square flange mount, E- or G-style servo mounts, or one of the standard face mounts, F1 for example. Consult factory for additional face mount options.
- The shaft seal is recommended in virtually all installations. The most common exceptions are applications requiring a very low starting torque or those requiring operation at both high temperature and high speed.
- Non-standard index widths and multiple indices are available by special order. Consult factory.
- Complementary outputs are recommended for use with line driver type (source/sink) outputs. When used with differential receivers, this combination provides a high degree of noise immunity.
- Output IC's:** Output IC's are available as either Line Driver (LD) or NPN Open Collector (OC) types. Open Collectors require pull-up resistors, resulting in higher output source impedance (sink impedance is similar to that of line drivers). In general, use of a Line Driver style output is recommended. Line Drivers source or sink current and their lower impedance mean better noise immunity and faster switching times. **Warning:** Do not connect any line driver outputs directly to circuit common/OV, which may damage the driver. Unused outputs should be isolated and left floating. Our applications specialists would be pleased to discuss your system requirements and the compatibility of your receiving electronics with Line Driver type outputs.
- 28V/V:** Multi-voltage Line Driver (7272*): 100 mA source/sink. Input voltage 5 to 28 VDC +/- 5% standard (Note: $V_{out} = V_{in}$). This driver is TTL compatible when used with 5 volt supply. Supply lines are protected against overvoltage to 60 volts and reverse voltage. Outputs are short circuit protected for one minute. Supply current is 120 mA typical (plus load current). This is the recommended replacement for 3904R and 7406R open collector outputs with internal pullup resistors. It is also a direct replacement for any 4469, 88C30, 8830 or 26LS31 line driver
- 28V/S:** Multi-voltage Line Driver (7272*): 100 mA source/sink. Input voltage 5 to 28 VDC +/- 5% standard, internally regulated with 5V (TTL compatible) logic out. Supply lines are protected against overvoltage to 60 volts and reverse voltage. Outputs are short circuit protected for one minute. Supply current is 90 mA typical (plus load current).
- 15V/V:** Multi-voltage Line Driver (4469*): 100 mA source/sink. Input voltage 5 to 15 VDC +/- 5% standard (Note: $V_{out} = V_{in}$). TTL compatible when used with 5 volt supply. Supply lines are protected against overvoltage to 60 volts and reverse voltage. Outputs are short circuit protected for one minute. Supply current is 90 mA typical (plus load current). This is a direct replacement for the 4469 Line Driver.
- 28V/OC:** NPN Open Collector (3904*, 7273*). Current sink of 80 mA max. Current sourced by external pull-up resistor. Output can be pulled up to voltage other than supply voltage (30 V max). Input voltage 5 to 28 VDC +/- 5% standard. Supply current is 120 mA typical. This replaces prior IC's with designations of 3904, 7406, 3302, 681 and 689. **5V/OCR, 15V/OCR, 24V/OCR:** Open Collector (3904R*, 7406R*, 7273R*): Current sink of 70 mA max. Includes internal pull-ups sized at approximately 100 ohms/volt. Max current source is 10 mA. Supply current is 100 mA typical, 120 mA with internal pull-ups. The 5V/OCR, 15V/OCR and 24V/OCR are often replaced by the 28V/V in system upgrades.
- 3904, 3904R, 4469, 5V/V, 5V/OC, 5V/OCR, 9V/OC:** Intrinsically safe line driver and open collector outputs. These drivers are specific to intrinsically safe encoders, and are installed per the appropriate control drawings listed in Table 2.1 on page 48.
- Special -S at the end of the model number is used to define a variety of non-standard features such as special shaft lengths, voltage options, or special testing. Please consult the factory to discuss your special requirements.
- Higher frequency response may be available. Please consult with the factory.
- Extended temperature ratings are available in the following ranges: -40 to 70°C, -40 to 85°C, -20 to 105°C and -40 to 105°C depending on the particular model. Some models can operate down to -55°C. Extended temperature ranges can affect other performance factors. Consult with factory for more specific information.
- Mating straight plug receptacles may be ordered from the factory: For M12 use MS3116F12-10S, For M14 use MS3106F14S-6S For M14/19 use MS3116J14-19S, For M16 use MS3106F16S-1S For M18 use MS3106F18-1S, For M20 use MS3106F20-29S