

1M X 32 DRAM DIMM Memory Module

FEATURES

- Performance range:

	t _{RAC}	t _{CAC}	t _{RC}
STI321000AD1-70	70ns	20ns	130ns
STI321000AD1-80	80ns	20ns	150ns

- Fast Page Mode operation
- CAS-before-RAS refresh capability
- RAS-only and Hidden refresh capability
- TTL compatible inputs and outputs
- Single +5.0V ± 10% power supply
- 1024 cycles/16ms refresh
- JEDEC standard pinout
- Available in tin or gold edge connectors

PIN CONFIGURATION

Pin	Symbol	Pin	Symbol	Pin	Symbol
1	V _{SS}	25	DQ ₁₂	49	DQ ₁₈
2	DQ ₀	26	DQ ₁₃	50	DQ ₁₉
3	DQ ₁	27	DQ ₁₄	51	DQ ₂₀
4	DQ ₂	28	A ₇	52	DQ ₂₁
5	DQ ₃	29	NC	53	DQ ₂₂
6	DQ ₄	30	V _{CC}	54	DQ ₂₃
7	DQ ₅	31	A ₈	55	NC
8	DQ ₆	32	A ₉	56	DQ ₂₄
9	DQ ₇	33	NC	57	DQ ₂₅
10	V _{CC}	34	RAS ₂	58	DQ ₂₆
11	PD ₁	35	DQ ₁₅	59	DQ ₂₈
12	A ₀	36	NC	60	DQ ₂₇
13	A ₁	37	DQ ₁₆	61	V _{CC}
14	A ₂	38	DQ ₁₇	62	DQ ₂₉
15	A ₃	39	V _{SS}	63	DQ ₃₀
16	A ₄	40	CAS ₀	64	DQ ₃₁
17	A ₅	41	CAS ₂	65	NC
18	A ₆	42	CAS ₃	66	PD ₂
19	NC	43	CAS ₁	67	PD ₃
20	NC	44	RAS ₀	68	PD ₄
21	DQ ₈	45	NC	69	PD ₅
22	DQ ₉	46	NC	70	PD ₆
23	DQ ₁₀	47	W	71	PD ₇
24	DQ ₁₁	48	NC	72	V _{SS}

GENERAL DESCRIPTION

The Simple Technology STI321000AD1 is a 1M bit x 32 Dynamic RAM high density memory module. The Simple Technology STI321000AD1 consists of two CMOS 1M x 16 bit DRAMs in 44-pin TSOP package mounted on a 72-pin glass epoxy substrate. A 0.1µF decoupling capacitor is mounted for each DRAM.

The STI321000AD1 is a Dual In-line Memory Module with tin (STI321000AD1-xxT) or gold (STI321000AD1-xxG) edge connections and is intended for mounting into 72-pin edge connector sockets.

Pin Names

Pin Name	Pin Function
A ₀ -A ₉	Address Inputs
DQ ₀ -DQ ₃₁	Data In/Out
W	Read/Write Input
RAS ₀ , RAS ₂	Row Address Strobe
CAS ₀ -CAS ₃	Column Address Strobe
PD ₁ -PD ₇	Presence Detect
V _{CC}	Power (+3.3V)
V _{SS}	Ground
NC	No Connection

Presence Detect Pins

For 1Mx32 Configuration with 1Mx16 chips:

PD₁=NC, PD₂=V_{SS}, PD₃=V_{SS}, PD₄=NC

Speed			
Pin	60ns	70ns	80ns
PD ₅	NC	V _{SS}	NC
PD ₆	NC	NC	V _{SS}
Refresh Mode			
Pin	Normal	Self Refresh	
PD ₇	NC	V _{SS}	

Odd numbered pins from pin 1 to pin 71 on front

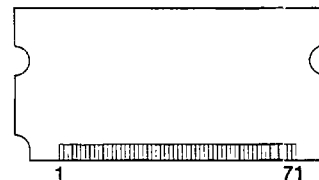

Even numbered pins from pin 2 to pin 72 on back

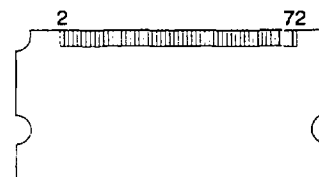

0051M

FUNCTIONAL BLOCK DIAGRAM

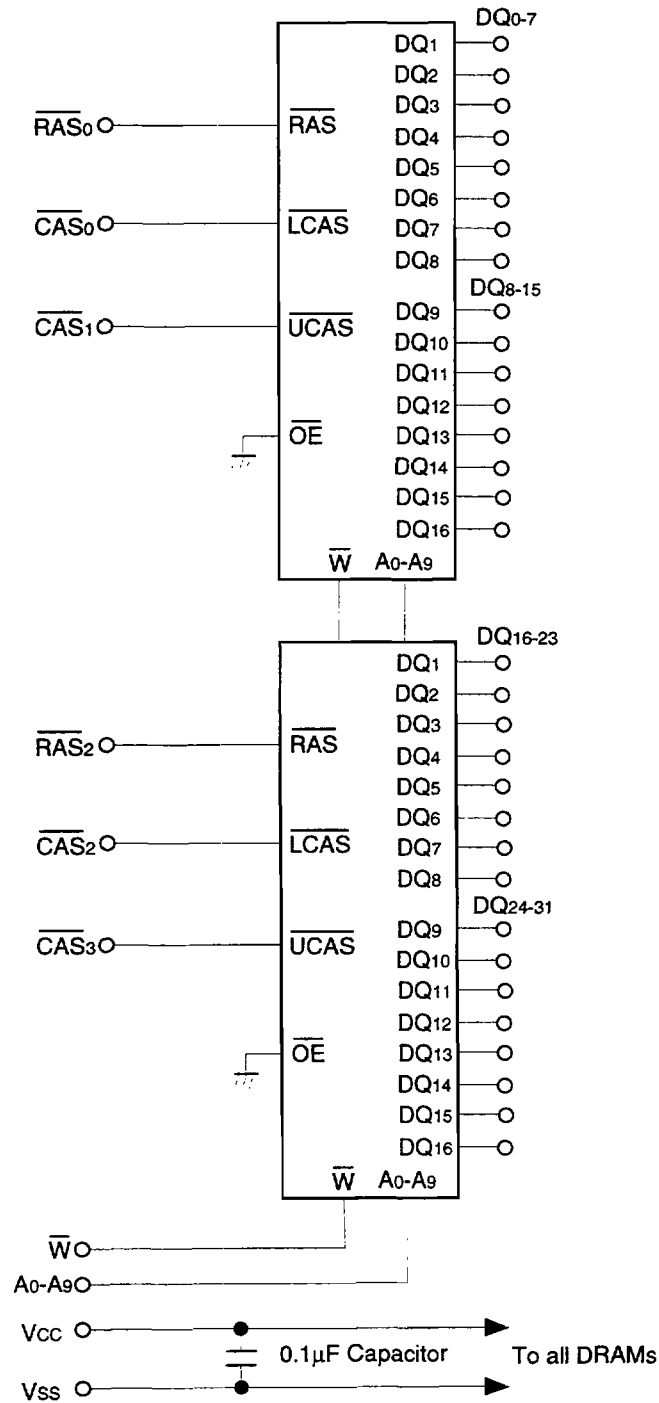

0086

ABSOLUTE MAXIMUM RATINGS*

Item	Symbol	Rating	Units
Voltage on Any Pin Relative to V_{SS}	V_{IN}, V_{OUT}	-1 to +7.0	V
Voltage on V_{CC} Supply Relative to V_{SS}	V_{CC}	-1 to +7.0	V
Storage Temperature	T_{stg}	-55 to +150	°C
Power Dissipation	P_D	4.8	W
Short Circuit Output Current	I_{OS}	50	mA

* Permanent device damage may occur if "ABSOLUTE MAXIMUM RATINGS" are exceeded. Functional Operation should be restricted to the conditions as detailed in the operational sections of this data sheet. Exposure to absolute maximum rating conditions for extended periods may affect device reliability.

RECOMMENDED OPERATING CONDITIONS (Voltage reference to V_{SS} , $T_A=0$ to 70°C)

Item	Symbol	Min	Typ	Max	Unit
Supply Voltage	V_{CC}	4.5	5.0	5.5	V
Ground	V_{SS}	0	0	0	V
Input High Voltage	V_{IH}	2.4	—	$V_{CC}+1$	V
Input Low Voltage	V_{IL}	-1.0	—	0.8	V

DC AND OPERATION CHARACTERISTICS

(Recommended operating conditions unless otherwise noted.)

Parameter		Symbol	Min	Max	Units
Operating Current* (RAS, CAS, Address Cycling @ $t_{RC}=\text{min.}$)	STI321000AD1-70	I_{CC1}	—	360	mA
	STI321000AD1-80		—	320	mA
Standby Current (RAS=CAS= V_{IH})		I_{CC2}	—	4	mA
RAS-Only Refresh Current* (CAS= V_{IH} , RAS Cycling @ $t_{RC}=\text{min.}$)	STI321000AD1-70	I_{CC3}	—	360	mA
	STI321000AD1-80		—	320	mA
Fast Page Mode Current* (RAS= V_{IL} , CAS Cycling: $t_{PC}=\text{min.}$)	STI321000AD1-70	I_{CC4}	—	160	mA
	STI321000AD1-80		—	140	mA
Standby Current (RAS=CAS= $V_{CC}-0.2V$)		I_{CC5}	—	2	mA
CAS-Before-RAS Refresh Current* (RAS and CAS Cycling @ $t_{RC}=\text{min.}$)	STI321000AD1-70	I_{CC6}	—	360	mA
	STI321000AD1-80		—	320	mA
Input Leakage Current (Any input $0 \leq V_{IN} \leq V_{CC} + 0.5V$, all other pins not under test = $0V$)		I_{IL}	-20	20	μA
Output Leakage Current (Data out is disabled, $0 \leq V_{OUT} \leq 3.6V$)		I_{OL}	-10	10	μA
Output High Voltage Level ($I_{OH}=-2\text{mA}$)		V_{OH}	2.4	—	V
Output Low Voltage Level ($I_{OL}=2\text{mA}$)		V_{OL}	—	0.4	V

*NOTE: I_{CC1} , I_{CC3} , I_{CC4} , and I_{CC6} are dependent on output loading and cycling rates. Specified values are obtained with the output open. I_{CC} is specified as an average current.

CAPACITANCE ($T_A=25\text{ }^\circ\text{C}$)

Item	Symbol	Min	Max	Units
Input Capacitance (A_0-A_9)	C_{IN1}	—	10	pF
Input Capacitance (\overline{W})	C_{IN2}	—	7	pF
Input Capacitance ($\overline{RAS}_0, \overline{RAS}_2$)	C_{IN3}	—	7	pF
Input Capacitance ($\overline{CAS}_0-\overline{CAS}_3$)	C_{IN4}	—	7	pF
Input/Output Capacitance ($DQ_{0-7, 8-15, 16-23, 24-31}$)	CDQ_1	—	7	pF

AC CHARACTERISTICS ($0\text{ }^\circ\text{C}\leq T_A\leq 70\text{ }^\circ\text{C}$, $V_{CC}=5.0V\pm 10\%$, See notes 1, 2)

Parameter	Symbol	STI321000AD1-70		STI321000AD1-80		Unit	Notes
		Min	Max	Min	Max		
Random read or write cycle time	t_{RC}	130		150		ns	
Access time from \overline{RAS}	t_{RAC}		70		80	ns	3, 4
Access time from \overline{CAS}	t_{CAC}		20		20	ns	3, 4, 5
Access time from column address	t_{AA}		35		40	ns	3, 11
\overline{CAS} to output in Low-Z	t_{CLZ}	0		0		ns	3
Output buffer turn-off delay	t_{OFF}	0	20	0	20	ns	7
Transition time (rise and fall)	t_T	3	50	3	50	ns	2
\overline{RAS} precharge time	t_{RP}	50		60		ns	
\overline{RAS} pulse width	t_{RAS}	70	10,000	80	10,000	ns	
\overline{RAS} hold time	t_{RSH}	20		20		ns	
\overline{CAS} hold time	t_{CSH}	70		80		ns	
\overline{CAS} pulse width	t_{CAS}	18	10,000	20	10,000	ns	
\overline{RAS} to \overline{CAS} delay time	t_{RCD}	20	50	20	60	ns	4
\overline{RAS} to column address delay time	t_{RAD}	15	35	15	40	ns	11
\overline{CAS} to \overline{RAS} precharge time	t_{CRP}	5		5		ns	
Row address set-up time	t_{ASR}	0		0		ns	
Row address hold time	t_{RAH}	10		10		ns	
Column address set-up time	t_{ASC}	0		0		ns	
Column address hold time	t_{CAH}	15		15		ns	
Column address hold referenced to \overline{RAS}	t_{AR}	55		60		ns	6
Column address to \overline{RAS} lead time	t_{RAL}	35		40		ns	
Read command set-up time	t_{RCS}	0		0		ns	
Read command hold referenced to \overline{CAS}	t_{RCH}	0		0		ns	9
Read command hold referenced to \overline{RAS}	t_{RRH}	0		0		ns	9
Write command hold time	t_{WCH}	15		15		ns	
Write command hold referenced to \overline{RAS}	t_{WCR}	55		60		ns	6
Write command pulse width	t_{WP}	15		15		ns	
Write command to \overline{RAS} lead time	t_{RWL}	20		20		ns	
Write command to \overline{CAS} lead time	t_{CWL}	15		15		ns	
Data-in set-up time	t_{DS}	0		0		ns	10
Data-in hold time	t_{DH}	15		15		ns	10
Data-in hold referenced to \overline{RAS}	t_{DHR}	55		60		ns	6
Refresh period	t_{REF}		16		16	ms	

continued on the next page

AC CHARACTERISTICS (continued)

Parameter	Symbol	STI321000AD1-70		STI321000AD1-80		Unit	Notes
		Min	Max	Min	Max		
Write command set-up time	t_{WCS}	0		0		ns	8
\overline{CAS} set-up time (C-B-R refresh)	t_{CSR}	10		10		ns	
\overline{CAS} hold time (C-B-R refresh)	t_{CHR}	15		15		ns	
\overline{RAS} precharge to \overline{CAS} hold time	t_{RPC}	5		5		ns	
Access time from \overline{CAS} precharge	t_{CPA}		40		45	ns	3
Fast Page mode cycle time	t_{PC}	45		50		ns	
\overline{CAS} precharge time (fast page)	t_{CP}	10		10		ns	
\overline{RAS} pulse width (fast page)	t_{RASP}	70	200,000	80	200,000	ns	
\overline{W} to \overline{RAS} precharge time (\overline{C} -B- \overline{R} refresh)	t_{WRP}	10		10		ns	
\overline{W} to \overline{RAS} hold time (C-B-R refresh)	t_{WRH}	10		10		ns	
\overline{CAS} precharge (C-B-R counter test)	t_{CPT}	30		30		ns	

NOTES

- An initial pause of 200 μ s is required after power-up followed by any 8 \overline{RAS} cycles before proper device operation is achieved.
- $V_{IH(min)}$ and $V_{IL(max)}$ are reference levels for measuring timing of input signals. Transition times are measured between $V_{IH(min)}$ and $V_{IL(max)}$, and are assumed to be 5ns for all inputs.
- Measure with a load equivalent to 2 TTL loads and 100pF.
- Operation within the $t_{RCD(max)}$ limit insures that $t_{RAC(max)}$ can be met. $t_{RCD(max)}$ is specified as a reference point only. If t_{RCD} is greater than the specified $t_{RCD(max)}$ limit, then access time is controlled exclusively by t_{CAC} .
- Assumes that $t_{RCD} \geq t_{RCD(max)}$.
- t_{AR} , t_{WCR} , t_{DHR} are referenced to $t_{RAD(max)}$.
- This parameter defines the time at which the output achieves the open circuit condition and is not referenced to V_{OH} or V_{OL} .
- t_{WCS} , t_{RWD} , t_{CWD} , and t_{AWD} are non-restrictive operating parameters. They are included in the data sheet as electrical characteristics only. If $t_{WCS} \geq t_{WCS(min)}$ the cycle is an early write cycle and the data out pin will remain high impedance for the duration of the cycle.
- Either t_{RCH} or t_{RRH} must be satisfied for a read cycle.
- These parameters are referenced to the \overline{CAS} leading edge in early write cycles and to the \overline{W} leading edge in read-write cycles.
- Operation within the $t_{RAD(max)}$ limit insures that $t_{RAC(max)}$ can be met. $t_{RAD(max)}$ is specified as a reference point only. If t_{RAD} is greater than the specified $t_{RAD(max)}$ limit, then access time is controlled by t_{AA} .

TIMING DIAGRAMS

Please refer to attached Timing Chart I.

PACKAGE DIMENSIONS

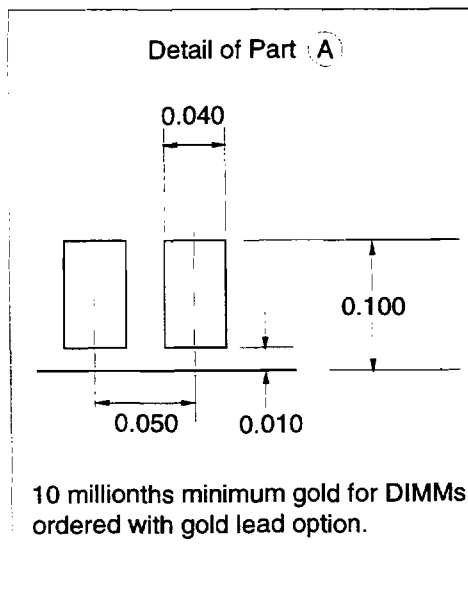
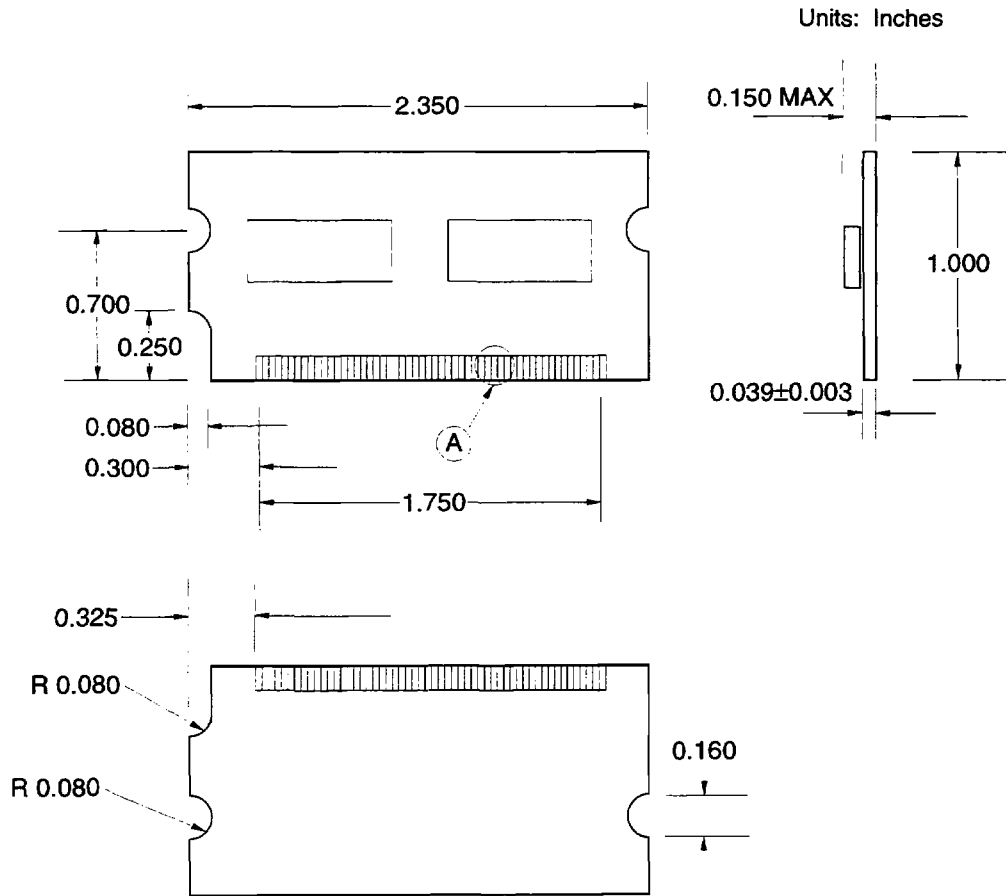

0052M

TOLERANCES: ±0.005 UNLESS OTHERWISE SPECIFIED