



# MEDIUM POWER OP-AMP

# 0041 SERIES

4707 Dey Road Liverpool, N.Y. 13088

(315) 701-6751

**FEATURES:**

- Available as SMD #5962-8508701
- Output Current - 0.5 Amps Peak
- Low Power Consumption-Class C Design
- Programmable Current Limit
- High Slew Rate
- Continuous Output Short Circuit Duration
- Replacement for LH0041
- Available in a surface mount package

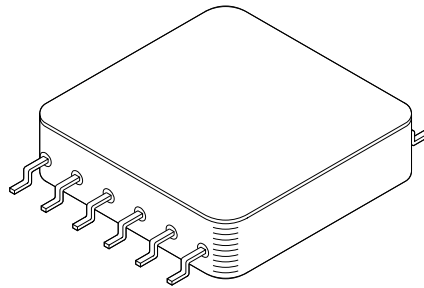

MSK0041FP

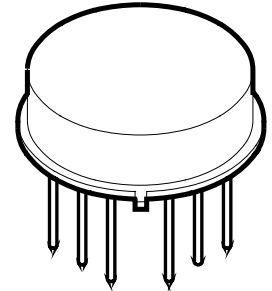

MSK0041

**DESCRIPTION:**

The MSK 0041 and 0041FP are general purpose Class C power operational amplifiers. These amplifiers offer high output currents, making them an excellent low cost choice for motor drive circuits. The amplifier and load can be protected from fault conditions through the use of internal current limit circuitry that can be user programmed with two external resistors. These devices are also compensated with a single external capacitor. The MSK 0041 is available in a hermetically sealed 12 pin TO-8 package. The MSK 0041FP is packaged in a 12 pin hermetic metal flatpack.

**EQUIVALENT SCHEMATIC**

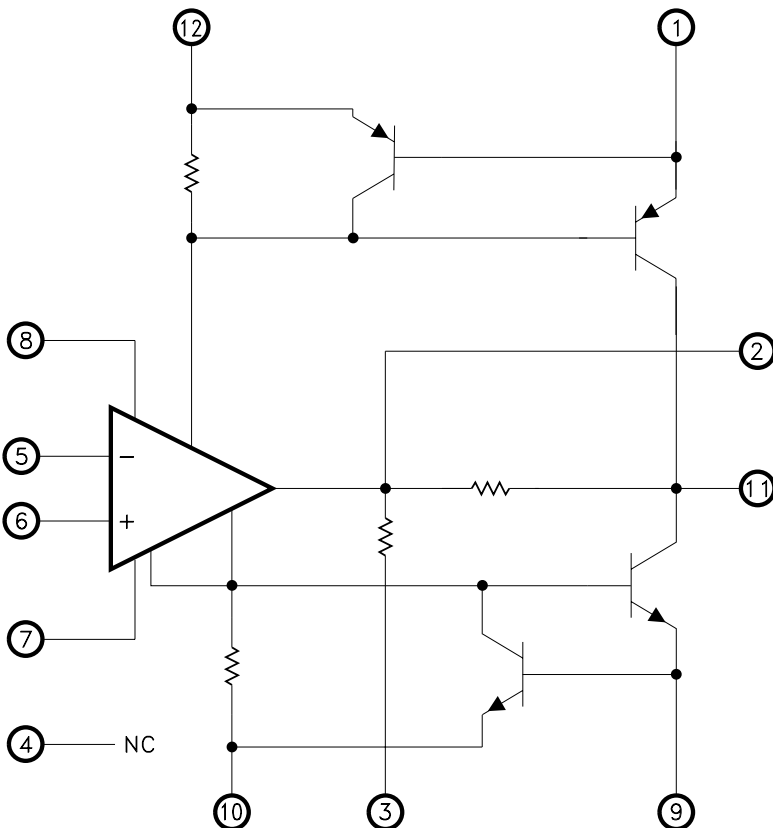

(PIN NUMBERS ARE FOR TO-8)

**TYPICAL APPLICATIONS**

- Servo Amplifier
- Motor Driver
- Audio Amplifier
- Programmable Power Supply

**PIN-OUT INFORMATION**

MSK0041	MSK0041 FP
1 ISC +	1 GND
2 Compensation	2 Balance
3 GND	3 -Input
4 NC	4 + Input
5 -Input	5 Balance
6 + Input	6 NC
7 Balance	7 -VCC
8 Balance	8 ISC-
9 ISC-	9 Output
10 -VCC	10 ISC +
11 Output	11 +VCC
12 +VCC	12 Compensation

## ABSOLUTE MAXIMUM RATINGS <sup>⑧</sup>

$\pm V_{CC}$	Supply Voltage	$\pm 18V$	T <sub>ST</sub>	Storage Temperature Range	$-65^{\circ}$ to $+150^{\circ}C$
I <sub>OUT</sub>	Peak Output Current	0.5A	T <sub>LD</sub>	Lead Temperature Range	300°C (10 Seconds)
V <sub>IN</sub>	Differential Input Voltage	$\pm 30V$	T <sub>J</sub>	Junction Temperature	150°C
V <sub>IN</sub>	Common Mode Input Voltage	$\pm 15V$	T <sub>C</sub>	Case Operating Temperature Range	Military Versions (H/B/E) $-55^{\circ}C$ to $+125^{\circ}C$ Industrial Versions $-40^{\circ}C$ to $+85^{\circ}C$
R <sub>TH</sub>	Thermal Resistance-Junction to Case				
	MSK 0041	85° C/W			
	MSK 0041FP	85° C/W			

## ELECTRICAL SPECIFICATIONS

Parameter	Test Conditions	Group A Subgroup	Military <sup>⑤</sup>			Industrial <sup>④</sup>			Units
			Min.	Typ.	Max.	Min.	Typ.	Max.	
<b>STATIC</b>									
Supply Voltage Range <sup>②</sup>		-	$\pm 5$	$\pm 15$	$\pm 18$	$\pm 5$	$\pm 15$	$\pm 18$	V
Quiescent Current	V <sub>IN</sub> = 0V	1, 2, 3	-	$\pm 1.0$	$\pm 3.5$	-	$\pm 1.0$	$\pm 4.0$	mA
Power Consumption <sup>②</sup>	V <sub>IN</sub> = 0V	1, 2, 3	-	75	105	-	90	120	mW
<b>INPUT</b>									
Input Offset Voltage	V <sub>IN</sub> = 0V	1	-	$\pm 0.5$	$\pm 3.0$	-	$\pm 0.5$	$\pm 6.0$	mV
		2, 3	-	$\pm 2.0$	$\pm 5.0$	-	-	-	$\mu V/^{\circ}C$
Input Bias Current	V <sub>CM</sub> = 0V Either Input	1	-	$\pm 100$	$\pm 300$	-	$\pm 150$	$\pm 500$	nA
		2, 3	-	$\pm 0.4$	$\pm 1.0$	-	-	-	$\mu A$
Input Offset Current	V <sub>CM</sub> = 0V	1	-	$\pm 2.0$	$\pm 100$	-	$\pm 2.0$	$\pm 200$	nA
		2, 3	-	-	$\pm 300$	-	-	-	nA
Input Capacitance <sup>③</sup>	F = DC	-	-	3	-	-	3	-	pF
Input Resistance <sup>②</sup>	F = DC	-	0.3	1.0	-	0.3	1.0	-	M $\Omega$
Common Mode Rejection Ratio	F = 10Hz V <sub>CM</sub> = $\pm 10V$	4	70	90	-	70	90	-	dB
		5, 6	70	90	-	-	-	-	dB
Power Supply Rejection Ratio	V <sub>CC</sub> = $\pm 5V$ to $\pm 15V$	1	80	95	-	80	95	-	dB
		2, 3	80	-	-	-	-	-	dB
Input Noise Voltage <sup>③</sup>	F = 10Hz to 10KHz	-	-	5	-	-	5	-	$\mu V_{RMS}$
<b>OUTPUT</b>									
Output Voltage Swing	R <sub>L</sub> = 100 $\Omega$ F = 100Hz	4	$\pm 13$	$\pm 14$	-	$\pm 13$	$\pm 14$	-	V
		5, 6	$\pm 13$	$\pm 14$	-	-	-	-	V
Output Short Circuit Current	R <sub>SC</sub> = 3.3 $\Omega$ V <sub>OUT</sub> = MAX	4	182	220	300	180	220	300	mA
Settling Time	0.1% 2V step	-	-	4	-	-	4	-	$\mu S$
<b>TRANSFER CHARACTERISTICS</b>									
Slew Rate <sup>③</sup>	V <sub>OUT</sub> = $\pm 10V$ R <sub>L</sub> = 100 $\Omega$	4	1.5	3.0	-	1.0	3.0	-	V/ $\mu S$
Open Loop Voltage Gain	F = 10Hz R <sub>L</sub> = 1K $\Omega$	4	100	105	-	100	105	-	dB
		5, 6	88	96	-	-	-	-	dB
Transition Times	V <sub>OUT</sub> = 1V Rise and Fall	4	-	0.3	1.0	-	0.3	1.5	$\mu S$
Overshoot	Small Signal	4	-	5	20	-	5	30	%

### NOTES:

- ① Unless otherwise specified,  $\pm V_{CC} = \pm 15V$ , C<sub>c</sub> = 3000pF.
- ② Guaranteed by design but not tested.
- ③ Typical parameters are representative of actual device performance but are for reference only.
- ④ Industrial grade and "E" suffix devices shall be tested to subgroups 1 and 4 unless otherwise specified.
- ⑤ Military grade devices (B/H suffix) shall be 100% tested to subgroups 1, 2, 3 and 4.  
 Subgroup 1, 4 T<sub>A</sub> = T<sub>C</sub> =  $+25^{\circ}C$   
 Subgroup 2, 5 T<sub>A</sub> = T<sub>C</sub> =  $+125^{\circ}C$   
 Subgroup 3, 6 T<sub>A</sub> = T<sub>C</sub> =  $-55^{\circ}C$
- ⑥ Reference DSCC SMD 5962-8508701 for electrical specifications for devices purchased as such.
- ⑦ Subgroup 5 and 6 testing available upon request.
- ⑧ Continuous operation at or above absolute maximum ratings may adversely effect the device performance and/or life cycle.

## APPLICATION NOTES

### HEAT SINKING

To select the correct heat sink for your application, refer to the thermal model and governing equation below.

#### Thermal Model:

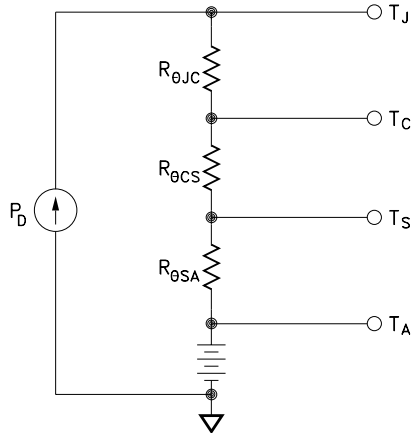

#### Governing Equation:

$$T_J = P_D \times (R_{\theta JC} + R_{\theta CS} + R_{\theta SA}) + T_A$$

Where

$T_J$	=	Junction Temperature
$P_D$	=	Total Power Dissipation
$R_{\theta JC}$	=	Junction to Case Thermal Resistance
$R_{\theta CS}$	=	Case to Heat Sink Thermal Resistance
$R_{\theta SA}$	=	Heat Sink to Ambient Thermal Resistance
$T_C$	=	Case Temperature
$T_A$	=	Ambient Temperature
$T_S$	=	Sink Temperature

#### Example: (TO-8 PACKAGE)

In our example the amplifier application requires the output to drive a 10 volt peak sine wave across a 100 ohm load for 0.1 amp of output current. For a worst case analysis we will treat the 0.1 amp peak output current as a D.C. output current. The power supplies are  $\pm 15$  VDC.

##### 1.) Find Power Dissipation

$$\begin{aligned} P_D &= [(\text{quiescent current}) \times (+V_{CC} - (V_{CC}))] + [(V_s - V_o) \times I_{OUT}] \\ &= (3.5 \text{ mA}) \times (30V) + (5V) \times (0.1A) \\ &= 0.1W + 0.5W \\ &= 0.6W \end{aligned}$$

##### 2.) For conservative design, set $T_J = +150^\circ\text{C}$ .

##### 3.) For this example, worst case $T_A = +25^\circ\text{C}$ .

##### 4.) $R_{\theta JC} = 85^\circ\text{C/W}$

##### 5.) Rearrange governing equation to solve for $R_{\theta SA}$ :

$$\begin{aligned} R_{\theta SA} &= (T_J - T_A) / P_D - (R_{\theta JC}) - (R_{\theta CS}) \\ &= (150^\circ\text{C} - 25^\circ\text{C}) / 0.6W - (85^\circ\text{C/W}) - (0.15^\circ\text{C/W}) \\ &= 123^\circ\text{C/W} \end{aligned}$$

The heat sink in this example must have a thermal resistance of no more than  $123^\circ\text{C/W}$  to maintain a junction temperature of less than  $+150^\circ\text{C}$ . This calculation assumes a case to sink thermal resistance of  $0.15^\circ\text{C/W}$ .

### CURRENT LIMIT

The MSK 0041 has an on-board current limit scheme designed to limit the output drivers anytime output current exceeds a predetermined limit. The following formula may be used to determine the value of the current limit resistance necessary to establish the desired current limit.

$$R_{SC} = \frac{0.7}{I_{SC}}$$

#### Current Limit Connection

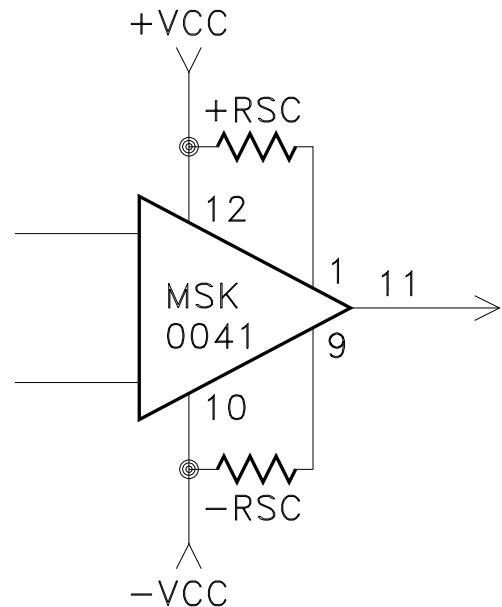

See "Application Circuits" in this data sheet for additional information on current limit connections.

### POWER SUPPLY BYPASSING

Both the negative and the positive power supplies must be effectively decoupled with a high and low frequency bypass circuit to avoid power supply induced oscillation. An effective decoupling scheme consists of a 0.1 microfarad ceramic capacitor in parallel with a 4.7 microfarad tantalum capacitor from each power supply pin to ground. This capacitor will eliminate any peak output voltage clipping which may occur due to poor power supply load regulation. All power supply decoupling capacitors should be placed as close to the package power supply pins as possible.

### SAFE OPERATING AREA

The safe operating area curve is a graphical representation of the power handling capability of the amplifier under various conditions. The wire bond current carrying capability, transistor junction temperature and secondary breakdown limitations are all incorporated into the safe operating area curves. All applications should be checked against the curves to ensure high M.T.B.F.

# APPLICATION CIRCUITS

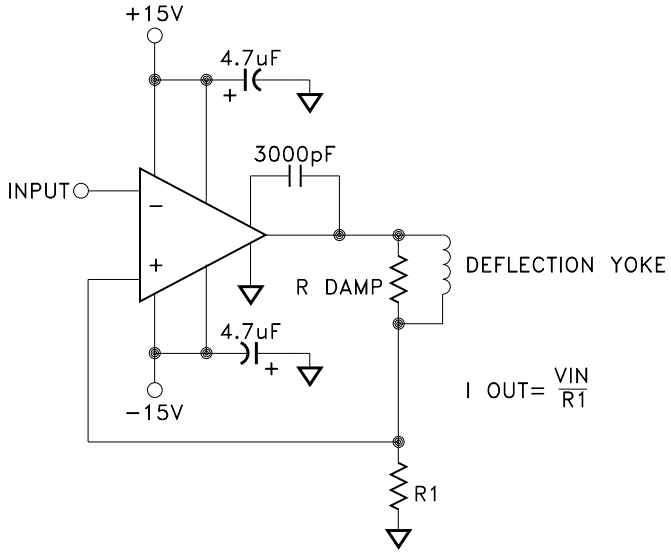

CRT DEFLECTION YOKE DRIVER

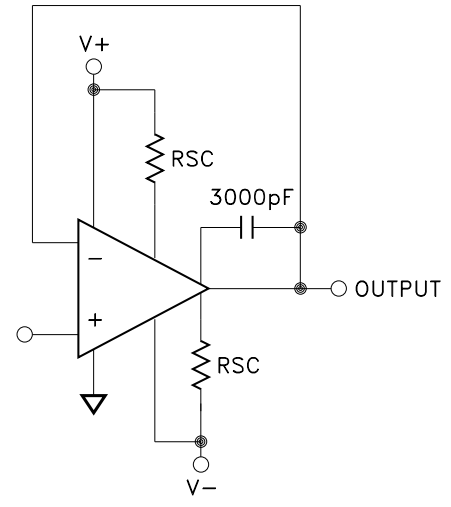

UNITY GAIN CIRCUIT WITH SHORT CIRCUIT LIMITING

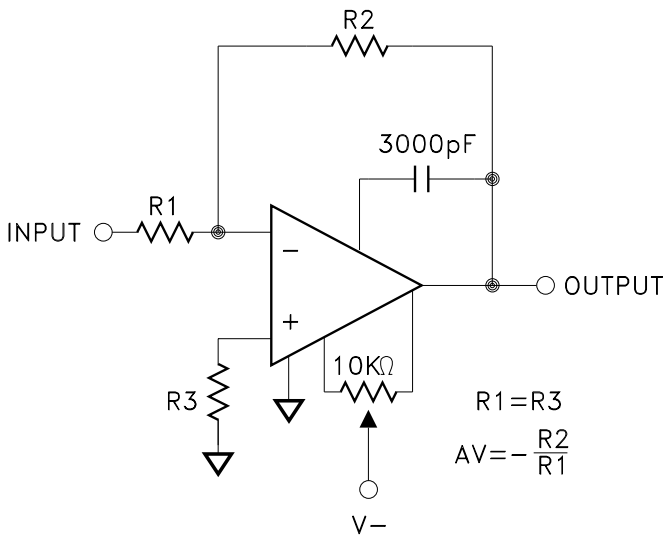

OFFSET VOLTAGE NULL CIRCUIT

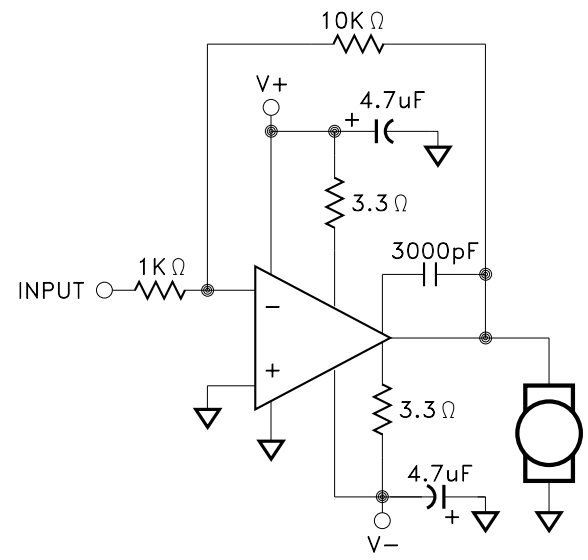

DC SERVO AMPLIFIER

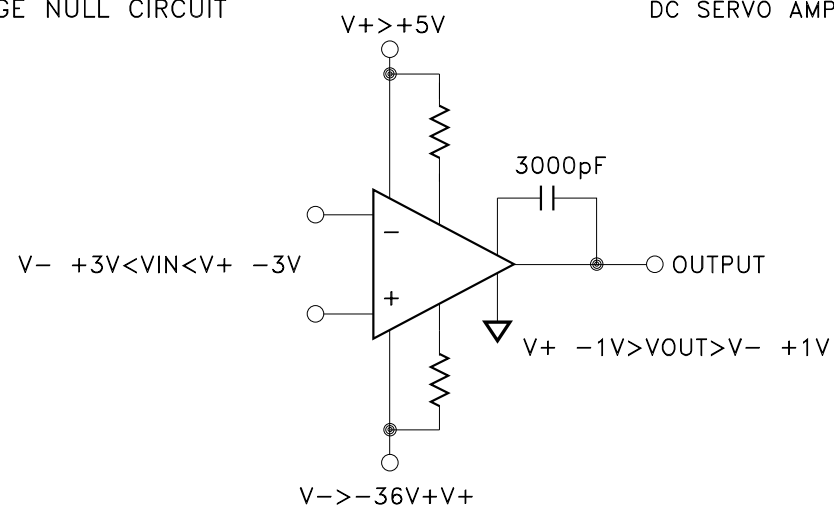

NON SYMMETRICAL SUPPLIES

# TYPICAL PERFORMANCE CURVES

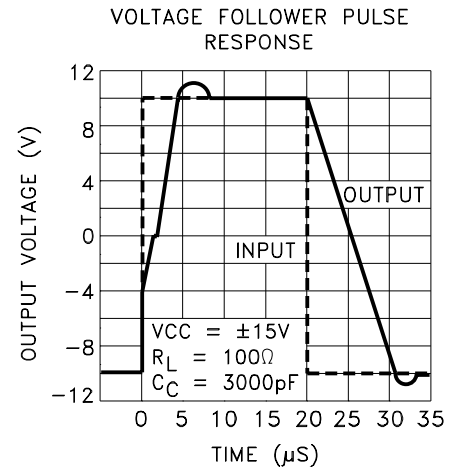
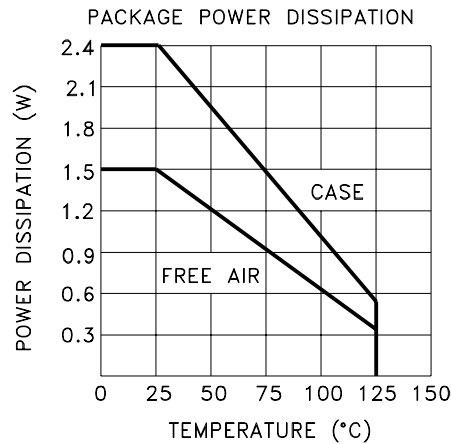
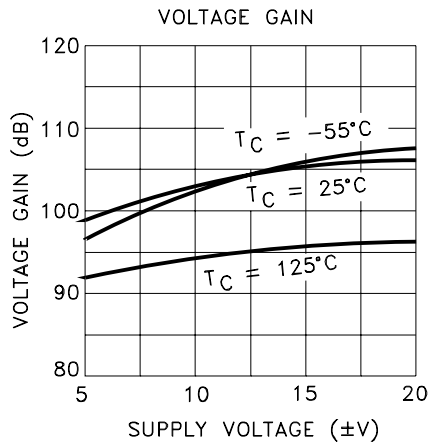
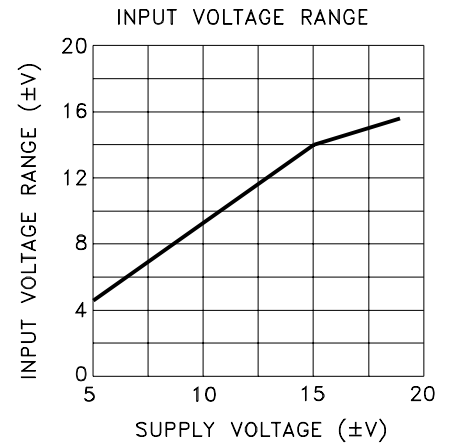
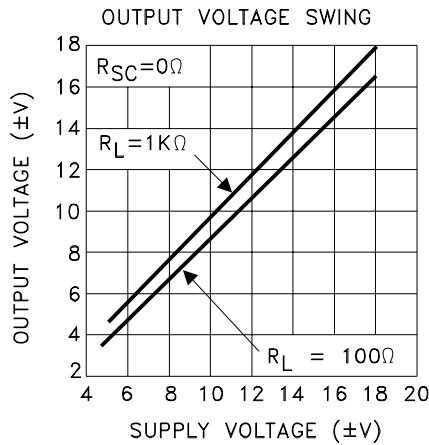
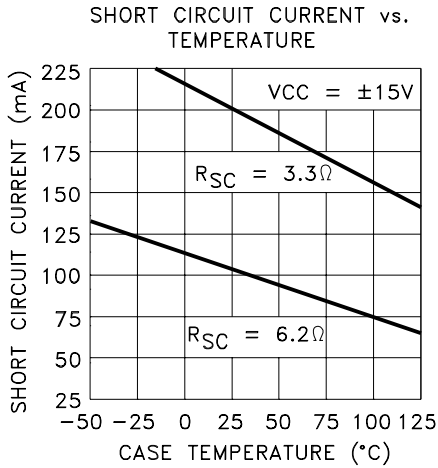
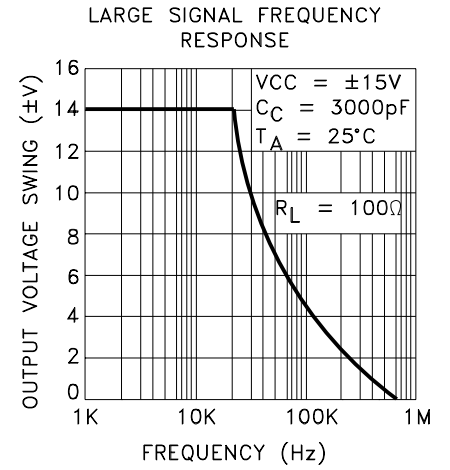
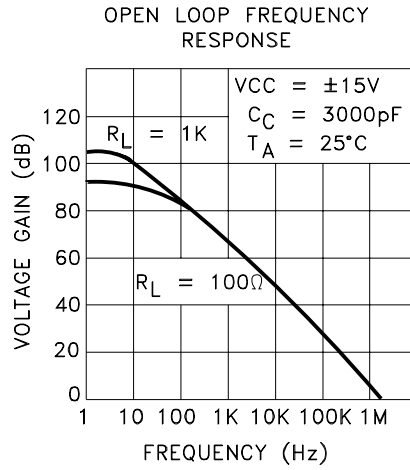
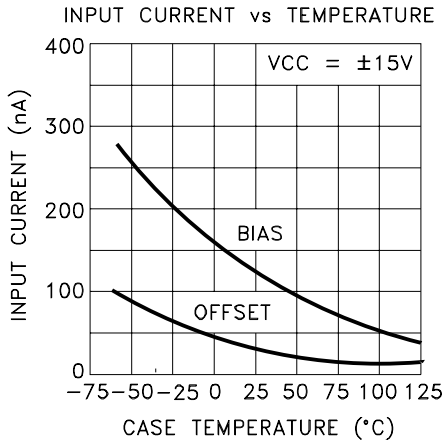

**MECHANICAL SPECIFICATIONS**

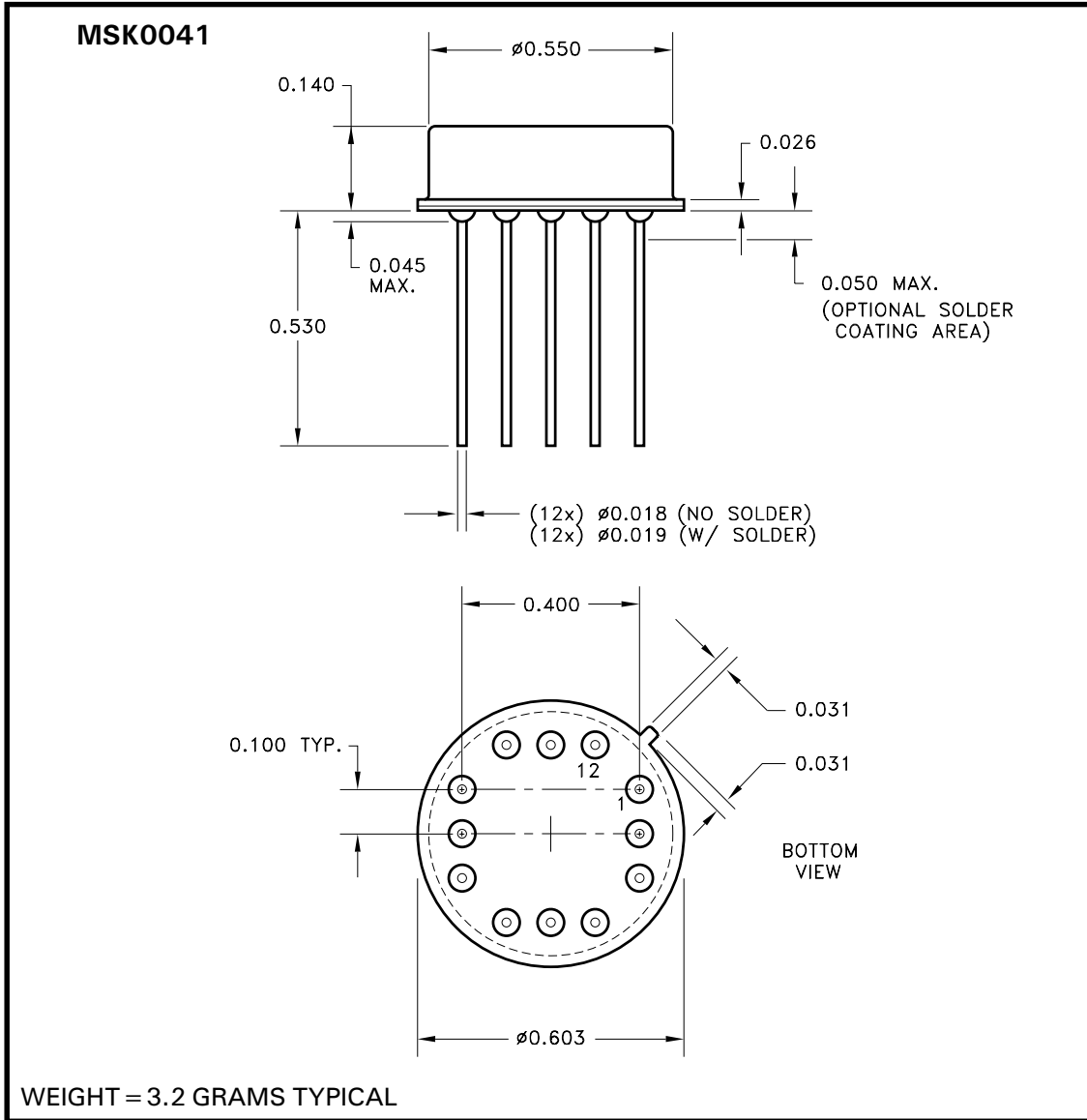

NOTE: ALL DIMENSIONS ARE  $\pm 0.010$  INCHES UNLESS OTHERWISE LABELED

**ORDERING INFORMATION**

Part Number	Screening Level
MSK 0041	Industrial
MSK 0041 B	MIL-PRF-38534 CLASS H
MSK 0041 E	EXTENDED RELIABILITY
5962-8508701X	DSCC - SMD

**MECHANICAL SPECIFICATIONS CONTINUED**

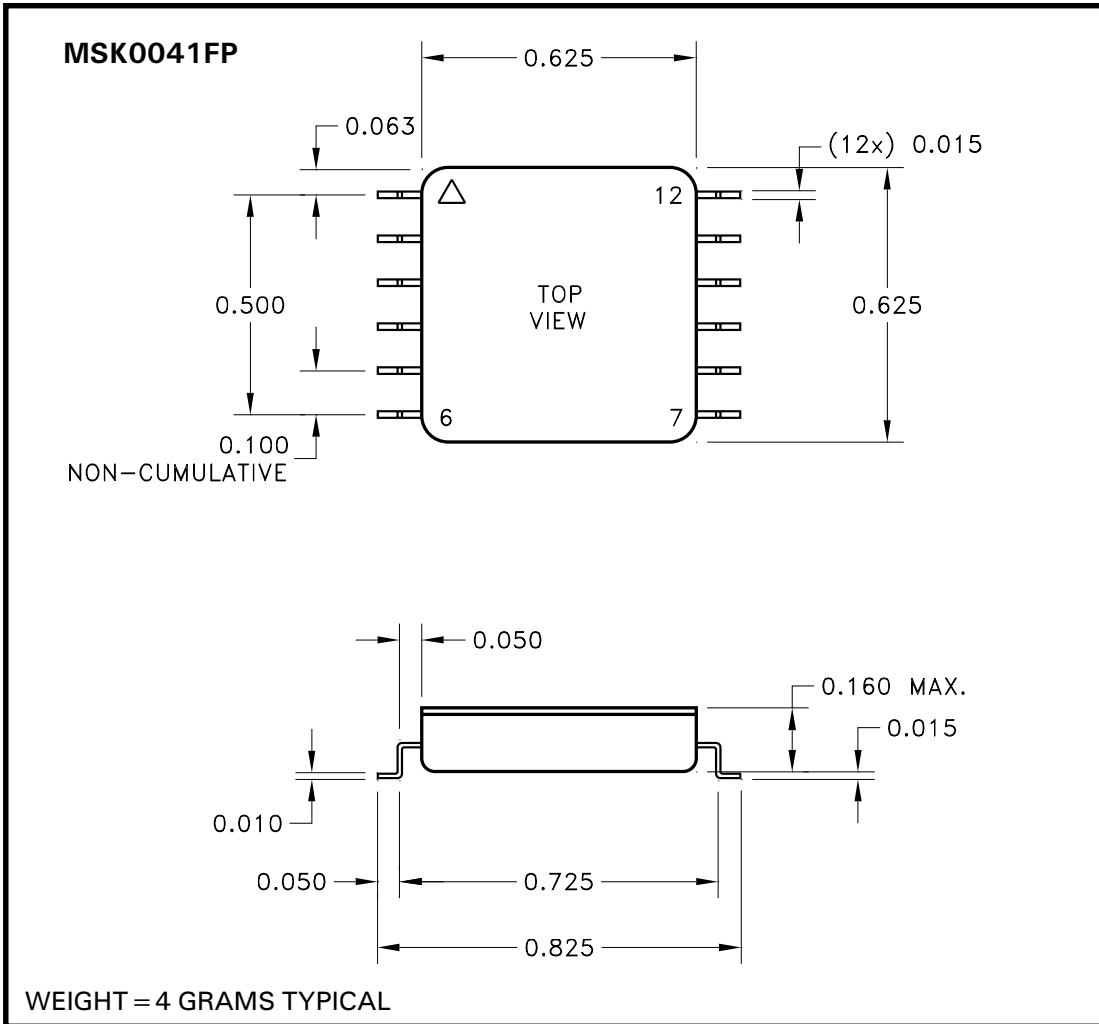

NOTE: ALL DIMENSIONS ARE  $\pm 0.010$  INCHES UNLESS OTHERWISE LABELED.  
ESD Triangle indicates pin 1.

**ORDERING INFORMATION**

Part Number	Screening Level
MSK 0041FP	Industrial
MSK 0041FP H	MIL-PRF-38534 CLASS H
MSK 0041FP E	EXTENDED RELIABILITY
TBD	DSCC - SMD

DEVICE IS ALSO AVAILABLE WITHOUT LEAD FORMING.

**M.S. Kennedy Corp.**  
4707 Dey Road, Liverpool, New York 13088  
Phone (315) 701-6751  
Fax (315) 701-6752  
www.mskennedy.com

The information contained herein is believed to be accurate at the time of printing. MSK reserves the right to make changes to its products or specifications without notice, however and assumes no liability for the use of its products. Please visit our website for the most recent revision of this datasheet