



**4 MEG x 16, 2 MEG x 16
ASYNC/PAGE CellularRAM MEMORY**

ASYNCHRONOUS CellularRAM™

**MT45W4MW16PFA
MT45W4ML16PFA**

**MT45W2MW16PFA
MT45W2ML16PFA**

Features

- Asynchronous and Page Mode interface
- Random Access Time: 70ns, 85ns
- Page Mode Read Access
Sixteen-word page size
Interpage read access: 70ns, 85ns
Intrapage read access: 20ns, 25ns
- VCC, VCCQ Voltages
1.70V–1.95V VCC
1.70V–2.25V VCCQ (Option W)
2.30V–2.70V VCCQ (Option V)
2.70V–3.30V VCCQ (Option L)
- Low Power Consumption
Asynchronous READ < 25mA
Intrapage READ < 15mA
Standby: 120µA (64Mb), 110µA (32Mb)—standard
100µA (64Mb), 90µA (32Mb)—low-power option
Deep Power-Down < 10µA
- Low-Power Features
Temperature Compensated Refresh (TCR)
Partial Array Refresh (PAR)
Deep Power-Down (DPD) Mode

Figure 1: 48-Ball VFBGA

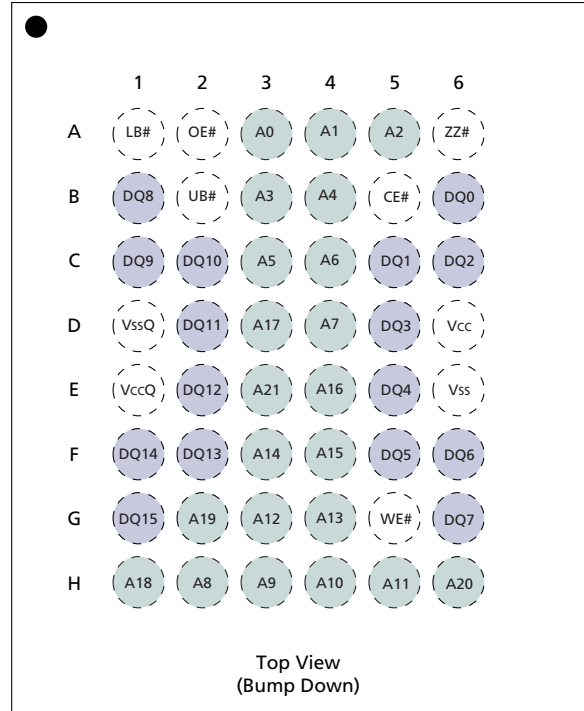

Options

- Configuration
4 Meg x 16
2 Meg x 16
- VCC Core Voltage Supply
1.8V – MT45WxMx16PFA
- VCCQ I/O Voltage
3.0V – MT45WxML16PFA
2.5V – MT45WxMV16PFA
1.8V – MT45WxMW16PFA
- Package
48-ball VFBGA
48-ball VFBGA—Lead-free
- Access Time
60ns
70ns
85ns

Designator

| | |
|-------------|------------------|
| MT45W4Mx16P | |
| MT45W2Mx16P | |
| | W |
| | L |
| | V ¹ |
| | W |
| | FA |
| | BA ¹ |
| | -60 ¹ |
| | -70 |
| | -85 |

NOTE:

See Table 1 on page 3 for Ball Descriptions. See Figure 22 on page 24 for the 48-ball mechanical drawing.

Options (continued)

- Standby Power
Standard
Low Power
- Operating Temperature Range
Wireless (-25°C to +85°C)
Industrial (-40°C to +85°C)

Designator

| |
|-----------------|
| None |
| L |
| WT |
| IT ¹ |

Part Number Example:
MT45W2ML16PFA-70LWT

NOTE:

1. Contact factory.



General Description

Micron® CellularRAM™ products are high-speed, CMOS dynamic random access memories that have been developed for low-power portable applications. The MT45W4Mx16PFA is a 64Mb device organized as 4 Meg x 16 bits, and the MT45W2Mx16PFA is a 32Mb device organized as 2 Meg x 16 bits. These devices include the industry-standard, asynchronous memory interface found on other low-power SRAM or Pseudo SRAM offerings.

Operating voltages have been reduced in an effort to minimize power consumption. The core voltage has been reduced to a 1.80V operating level. To maintain compatibility with different memory bus interfaces, CellularRAM devices are available with I/O voltages of 3.00V, 2.50V or 1.80V.

A user-accessible configuration register (CR) defines how the CellularRAM device performs on-chip refresh and whether page mode read accesses are permitted. This register is automatically loaded with a default setting during power-up and can be updated at any time during normal operation.

To operate seamlessly on an asynchronous memory bus, CellularRAM products incorporate a transparent self refresh mechanism. The hidden refresh requires no additional support from the system memory controller and has no significant impact on device read/write performance.

Special attention has been focused on current consumption during self refresh. CellularRAM products include three system-accessible mechanisms used to minimize refresh current. Temperature compensated refresh (TCR) is used to adjust the refresh rate according to the case temperature. The refresh rate can be decreased at lower temperatures to minimize current consumption during standby. Setting the sleep enable pin ZZ# to LOW enables one of two low-power modes: partial array refresh (PAR); or deep power-down (DPD). PAR limits refresh to only that part of the DRAM array that contains essential data. DPD halts refresh operation altogether and is used when no vital information is stored in the device. These three refresh mechanisms are accessed through the CR.

**Figure 2: Functional Block Diagram
4 Meg x 16 and 2 Meg x 16**

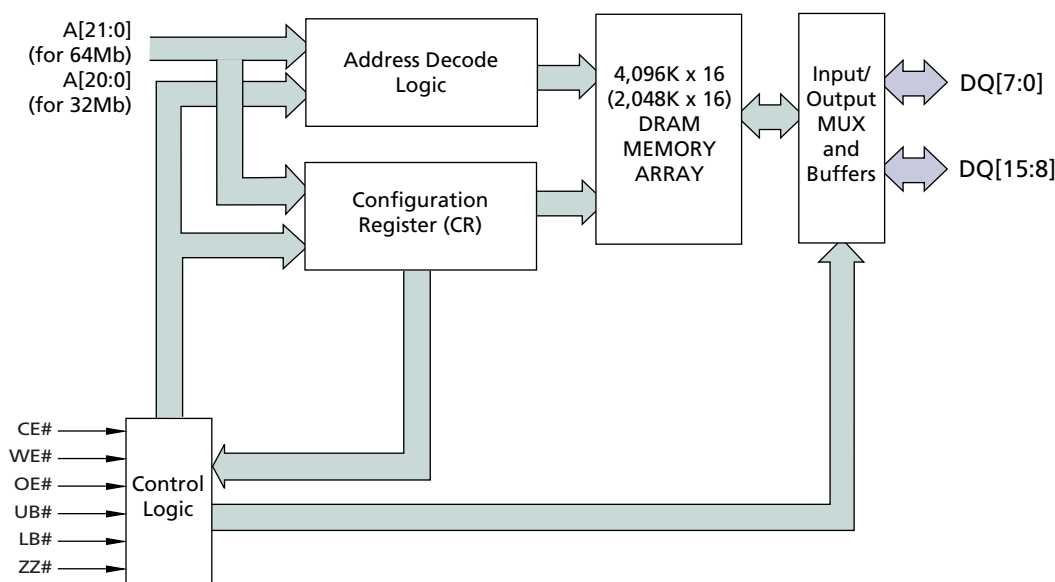

NOTE:

Functional block diagrams illustrate simplified device operation. See truth table, pin descriptions, and timing diagrams for detailed information.

Table 1: VFBGA Ball Descriptions

| VFBGA BALL ASSIGNMENT | SYMBOL | TYPE | DESCRIPTION |
|--|----------|--------------|---|
| A3, A4, A5, B3, B4, C3, C4, D4, H2, H3, H4, H5, G3, G4, F3, F4, E4, D3, H1, G2, H6, E3 | A[21:0] | Input | Address Inputs: Inputs for the address accessed during READ or WRITE operations. The address lines are also used to define the value to be loaded into the CR. On the 32Mb device, A21 (ball E3) is not internally connected. |
| A6 | ZZ# | Input | Sleep Enable: When ZZ# is LOW, the CR can be loaded or the device can enter one of two low-power modes (DPD or PAR). |
| B5 | CE# | Input | Chip Enable: Activates the device when LOW. When CE# is HIGH, the device is disabled and goes into standby power mode. |
| A2 | OE# | Input | Output Enable: Enables the output buffers when LOW. When OE# is HIGH, the output buffers are disabled. |
| G5 | WE# | Input | Write Enable: Enables WRITE operations when LOW. |
| A1 | LB# | Input | Lower Byte Enable. DQ[7:0] |
| B2 | UB# | Input | Upper Byte Enable. DQ[15:8] |
| B6, C5, C6, D5, E5, F5, F6, G6, B1, C1, C2, D2, E2, F2, F1, G1 | DQ[15:0] | Input/Output | Data Inputs/Outputs. |
| D6 | Vcc | Supply | Device Power Supply: (1.7V–1.95V) Power supply for device core operation. |
| E1 | VccQ | Supply | I/O Power Supply: (1.8V, 2.5V, 3.0V) Power supply for input/output buffers. |
| E6 | Vss | Supply | Vss must be connected to ground. |
| D1 | VssQ | Supply | VssQ must be connected to ground. |

Table 2: Bus Operations

| MODE | POWER | CE# | WE# | OE# | LB#/UB# | ZZ# | DQ[15:0] ¹ | NOTES |
|-----------------------------|-----------------------|-----|-----|-----|---------|-----|-----------------------|---------|
| Standby | Standby | H | X | X | X | H | High-Z | 2, 5 |
| Read | Active | L | H | L | L | H | Data-Out | 1, 4 |
| Write | Active | L | L | X | L | H | Data-In | 1, 3, 4 |
| No Operation | Idle | L | X | X | X | H | X | 4, 5 |
| PAR | Partial Array Refresh | H | X | X | X | L | High-Z | 6 |
| DPD | Deep Power-Down | H | X | X | X | L | High-Z | 6 |
| Load Configuration Register | Active | L | L | X | X | L | High-Z | |

NOTE:

- When LB# and UB# are in select mode (LOW), DQ[15:0] are affected. When LB# only is in select mode, only DQ[7:0] are affected. When UB# only is in the select mode, DQ[15:8] are affected.
- When the device is in standby mode, control inputs (WE#, OE#), address inputs, and data inputs/outputs are internally isolated from any external influence.
- When WE# is invoked, the OE# input is internally disabled and has no effect on the I/Os.
- The device will consume active power in this mode whenever addresses are changed.
- V_{IN} = VccQ or 0V; all device balls must be static (unswitched) in order to achieve minimum standby current.
- DPD is enabled when configuration register bit CR[4] is "0"; otherwise, PAR is enabled.



Part-Numbering Information

Micron CellularRAM devices are available in several different configurations and densities (see Figure 3)

Figure 3: Part Number Chart

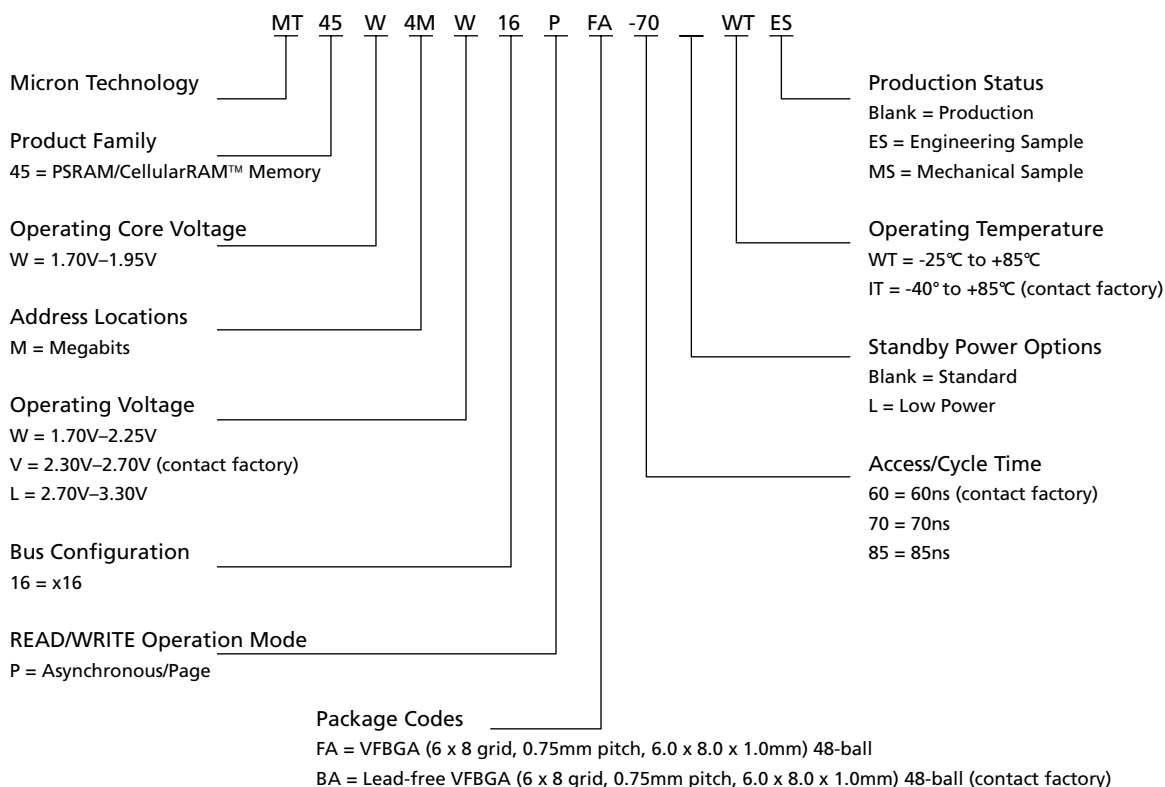

Valid Part Number combinations

After building the part number from the part numbering chart above, please go to the Micron Part Marking Decoder Web site at www.micron.com/partsearch to verify that the part number is offered and valid. If the device required is not on this list, please contact the factory.

Device Marking

Due to the size of the package, the Micron standard part number is not printed on the top of the device. Instead, an abbreviated device mark comprised of a five-digit alphanumeric code is used. The abbreviated device marks are cross-referenced to the Micron part numbers at www.micron.com/partsearch. To view the location of the abbreviated mark on the device, please refer to customer service note, CSN-11, "Product Mark/Label," at www.micron.com/csn.



Functional Description

In general, the MT45W4Mx16PFA device and the MT45W2Mx16PFA device are high-density alternatives to SRAM and Pseudo SRAM products, popular in low-power, portable applications. The MT45W4Mx16PFA contains 67,108,864 bits organized as 4,194,304 addresses by 16 bits. The MT45W2Mx16PFA contains 33,554,432 bits organized as 2,097,152 addresses by 16 bits. These devices include the industry-standard, asynchronous memory interface found on other low-power SRAM or Pseudo SRAM offerings. Page mode accesses are also included as a bandwidth-enhancing extension to the asynchronous read protocol.

Power-Up Initialization

CellularRAM products include an on-chip voltage sensor that is used to launch the power-up initialization process. Initialization will load the CR with its default settings. VCC and VCCQ must be applied simultaneously, and when they reach a stable level above 1.70V, the device will require 150 μ s to complete its self-initialization process (see Figure 4 below). During the initialization period, CE# should remain HIGH. When initialization is complete, the device is ready for normal operation. At power-up, the CR is set to 0070h.

Figure 4: Power-Up Initialization Timing

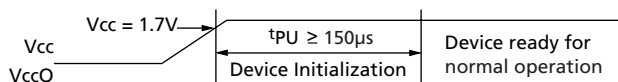

Bus Operating Modes

The MT45W4Mx16PFA and the MT45W2Mx16PFA CellularRAM products incorporate the industry-standard, asynchronous interface found on other low-power SRAM or Pseudo SRAM offerings. This bus interface supports asynchronous READ and WRITE operations as well as the bandwidth-enhancing page mode READ operation. The specific interface that is supported is defined by the value loaded into the CR.

Asynchronous Mode

CellularRAM products power up in the asynchronous operating mode. This mode uses the industry-standard SRAM control interface (CE#, OE#, WE#, LB#/UB#). READ operations (Figure 5) are initiated by bringing CE#, OE#, and LB#/UB# LOW while keeping WE# HIGH. Valid data will be driven out of the I/Os after the specified access time has elapsed. WRITE operations (Figure 6) occur when CE#, WE#, and LB#/UB# are driven LOW. During WRITE operations, the level of OE# is a "Don't Care"; WE# will override OE#. The data to be written will be latched on the rising edge of CE#, WE#, or LB#/UB# (whichever occurs first). WE# LOW time must be limited to t_{CEM} .

Figure 5: READ Operation

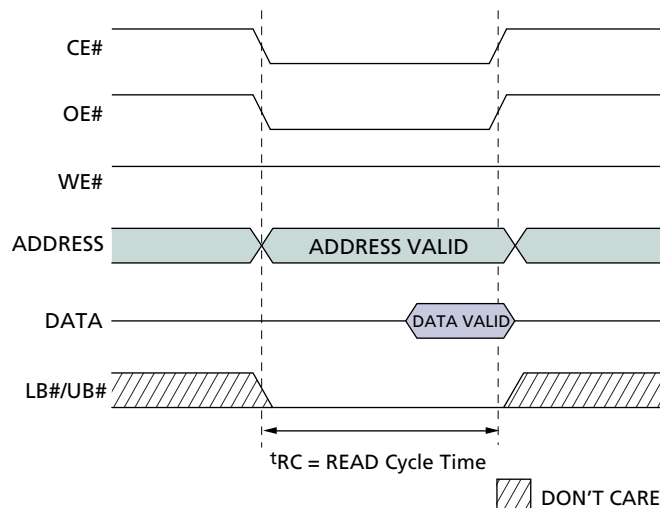
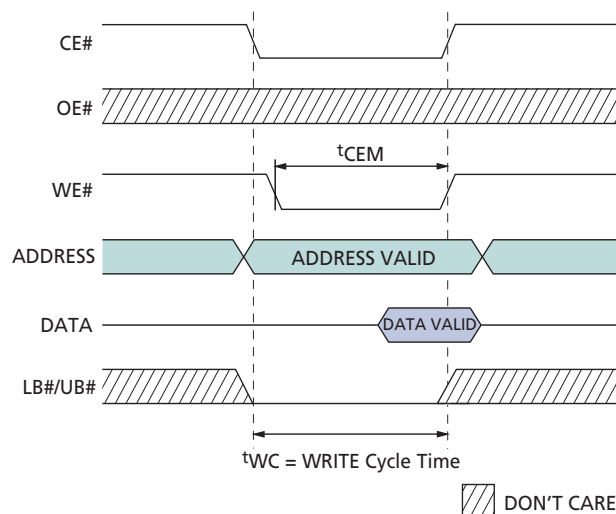

Figure 6: WRITE Operation





Page Mode READ Operation

Page mode is a performance-enhancing extension to the legacy asynchronous READ operation. In page-mode-capable products, an initial asynchronous read access is performed, then adjacent addresses can be quickly read by simply changing the low-order address. Addresses A[3:0] are used to determine the members of the 16-address CellularRAM page. Any changes in addresses A[4] or higher will initiate a new t_{AA} access. Figure 7 shows the timing diagram for a page mode access.

Page mode takes advantage of the fact that adjacent addresses can be read in a shorter period of time than random addresses. WRITE operations do not include comparable page mode functionality.

The CE# LOW time is limited by refresh considerations. CE# must not stay LOW longer than t_{CEM} .

Figure 7: Page READ Operation

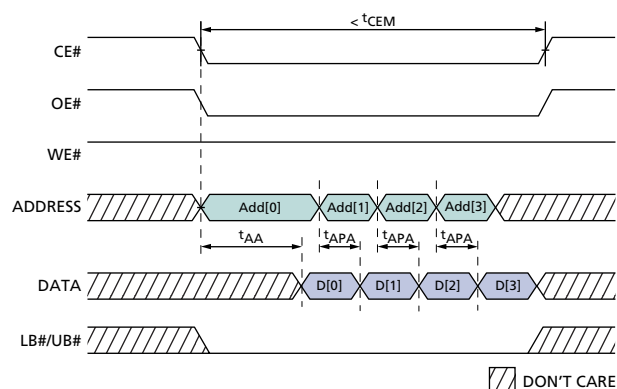

LB#/UB# Operation

The lower byte (LB#) enable and upper byte (UB#) enable signals allow for byte-wide data transfers. During READ operations, enabled bytes are driven onto the DQs. The DQs associated with a disabled byte are put into a High-Z state during a READ operation. During WRITE operations, any disabled bytes will not be transferred to the memory array and the internal value will remain unchanged. During a WRITE cycle, the data to be written is latched on the rising edge of CE#, WE#, LB#, or UB#, whichever occurs first.

When both the LB# and UB# are disabled (HIGH) during an operation, the device will disable the data bus from receiving or transmitting data. Although the device will seem to be deselected, the device remains in an active mode as long as CE# remains LOW.

Low Power Operation

Standby Mode Operation

During standby, the device current consumption is reduced to the level necessary to perform the DRAM refresh operation on the full array. Standby operation occurs when CE# and ZZ# are HIGH.

The device will enter a reduced power state during READ and WRITE operations where the address and control inputs remain static for an extended period of time. This mode will continue until a change occurs to the address or control inputs.

Temperature Compensated Refresh

Temperature compensated refresh (TCR) is used to adjust the refresh rate depending on the device operating temperature. DRAM technology requires more frequent refresh operations to maintain data integrity as temperatures increase. More frequent refresh is required due to the increased leakage of the DRAM's capacitive storage elements as temperatures rise. A decreased refresh rate at lower temperatures will facilitate a savings in standby current.

TCR allows for adequate refresh at four different temperature thresholds: +15°C, +45°C, +70°C, and +85°C. The setting selected must be for a temperature higher than the case temperature of the CellularRAM device. For example, if the case temperature is +50°C, the system can minimize self refresh current consumption by selecting the +70°C setting. The +15°C and +45°C settings would result in inadequate refreshing and cause data corruption.

Partial Array Refresh

Partial array refresh (PAR) restricts refresh operation to a portion of the total memory array. This feature enables the system to reduce refresh current by only refreshing that part of the memory array that is absolutely necessary. The refresh options are full array, one-half array, one-quarter array, one-eighth array, or none of the array. Data stored in addresses not receiving refresh will become corrupted. The mapping of these partitions can start at either the beginning or the end of the address map (Tables 4 and 5 on page 11). READ and WRITE operations are ignored during PAR operation.

The device only enters PAR mode if the SLEEP bit in the CR has been set HIGH (CR[4] = 1). PAR can be initiated by bring the ZZ# pin to the LOW state for longer than 10 μ s. Returning ZZ# to HIGH will cause an exit from PAR and the entire array will be immediately available for READ and WRITE operations.



Alternatively, PAR can be initiated using the CR software access sequence (see Software Access to the Configuration Register on page 8). PAR is enabled immediately upon setting CR[4] to "1" using this method. However, using software access to write to the CR alters the function of the ZZ# pin so that ZZ# LOW no longer initiates PAR, although ZZ# continues to enable WRITES to the CR. This functional change persists until the next time the device is powered up. (See Figure 8.)

Deep Power-Down Operation

Deep power-down (DPD) operation disables all refresh-related activity. This mode is used when the system does not require the storage provided by the CellularRAM device. Any stored data will become corrupted when DPD is entered. When refresh activity has been re-enabled, the CellularRAM device will require 150 μ s to perform an initialization procedure before normal operations can resume. READ and WRITE operations are ignored during DPD operation.

The device can only enter DPD if the SLEEP bit in the CR has been set LOW (CR[4] = 0). DPD is initiated by bringing the ZZ# pin to the LOW state for longer than 10 μ s. Returning ZZ# to HIGH will cause the device to exit DPD and begin a 150 μ s initialization process. During this 150 μ s period, the current consumption will be higher than the specified standby levels but considerably lower than the active current specification.

Driving the ZZ# pin LOW will place the device in the PAR mode if the SLEEP bit in the CR has been set HIGH (CR[4] = 1).

The device should not be put into DPD using CR software access.

Figure 8: Software Access PAR Functionality

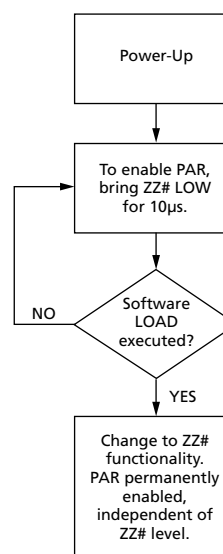



Configuration Register Operation

The configuration register (CR) defines how the CellularRAM device performs its transparent self refresh. Altering the refresh parameters can dramatically reduce current consumption during standby mode. Page mode control is also embedded into the CR. This register can be updated anytime while the device is operating in a standby state. Table 3 on page 11 describes the control bits used in the CR. At power up, the CR is set to 0070h.

Access Using ZZ#

The CR can be loaded using a WRITE operation immediately after ZZ# makes a HIGH-to-LOW transition (Figure 9). The values placed on addresses A[21:0] are latched into the CR on the rising edge of CE# or WE#, whichever occurs first. LB#/UB# are "Don't Care." Access using ZZ# is WRITE only.

Figure 9: Load Configuration Register Operation

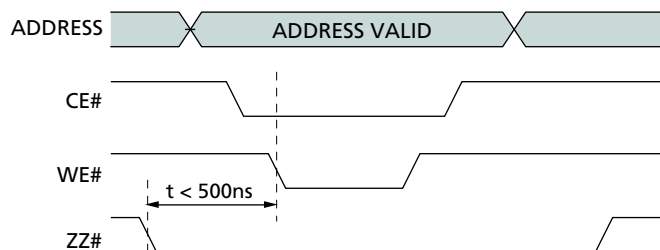

Software Access to the Configuration Register

The contents of the CR can either be read or modified using a software sequence. The nature of this access mechanism may eliminate the need for the ZZ# pin.

If the software mechanism is used, the ZZ# pin can simply be tied to VCCQ. The port line typically used for ZZ# control purposes will no longer be required. However, ZZ# should not be tied to VCCQ if the system will use DPD; DPD cannot be enabled or disabled using the software access sequence.

The CR is loaded using a four-step sequence consisting of two READ operations followed by two WRITE operations (see Figure 9). The read sequence is virtually identical except that an asynchronous READ is performed during the fourth operation (see Figure 10 on page 9).

The address used during all READ and WRITE operations is the highest address of the CellularRAM device being accessed (3FFFFFFh for 64Mb and 1FFFFFFh for 32Mb); the contents of this address are not changed by using this sequence. The data bus is used to transfer data into or out of the CR.

Writing to the CR using the software sequence modifies the function of the ZZ# pin. Once the software sequence loads the CR, the level of the ZZ# pin no longer enables PAR operation. PAR operation will be updated whenever the software sequence loads a new value into the CR. This ZZ# functionality will continue until the next time the device is powered-up. The operation of the ZZ# pin is not affected if the software sequence is only used to read the contents of the CR. The use of the software sequence does not affect the ability to perform the standard (ZZ# controlled) method of loading the CR.



Figure 10: Software Access Load Configuration Register

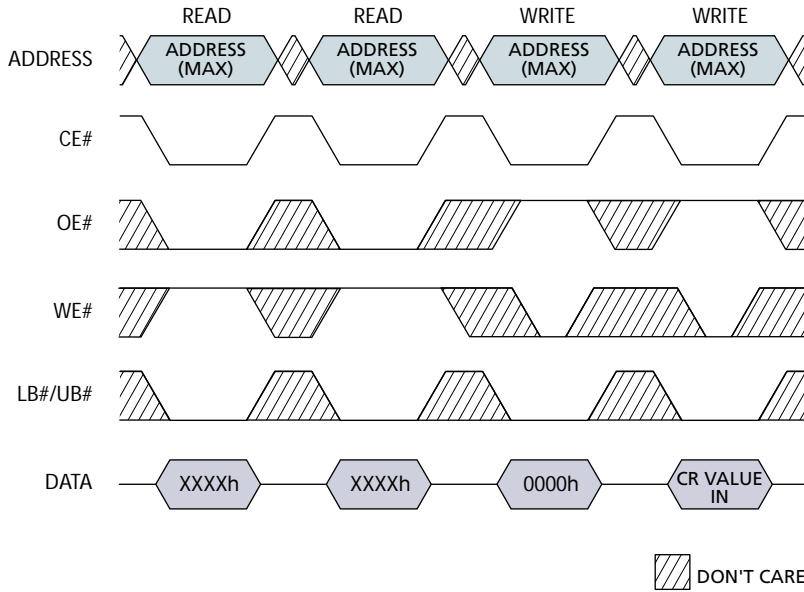
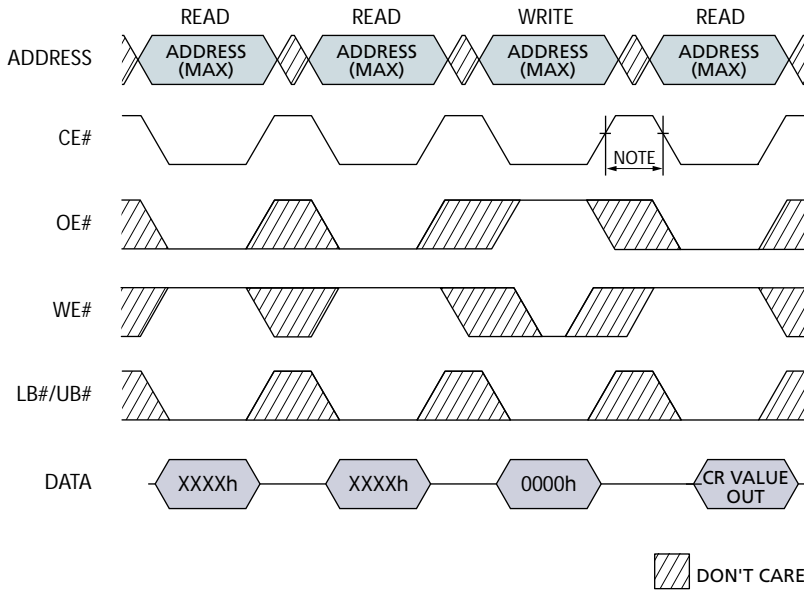

Figure 11: Software Access Read Configuration Register



NOTE:

CE# must be HIGH for 150ns before performing the cycle that reads the configuration register.

Partial Array Refresh (CR[2:0])
Default = Full Array Refresh

The PAR bits restrict refresh operation to a portion of the total memory array. This feature allows the system to reduce current by only refreshing that part of the memory array required by the host system. The refresh options are full array, one-half array, one-quarter array, one-eighth array, or none of the array. The mapping of these partitions can start at either the beginning or the end of the address map (see Tables 4 and 5 on page 11).

Sleep Mode (CR[4])
Default = PAR Enabled, DPD Disabled

The sleep mode bit determines which low-power mode is to be entered when $\overline{ZZ\#}$ is driven LOW. If CR[4] = 1, PAR operation is enabled. If CR[4] = 0, DPD operation is enabled. PAR can also be enabled directly by writing to the CR using the software access sequence. Note that this then disables $\overline{ZZ\#}$ initiation of PAR. DPD cannot be enabled or disabled using the software access sequence; this should only be done using $\overline{ZZ\#}$ to access the CR.

DPD operation disables all refresh-related activity. This mode will be used when the system does not require the storage provided by the CellularRAM device. Any stored data will become corrupted when DPD is enabled. When refresh activity has been re-enabled, the CellularRAM device will require 150 μ s to perform an initialization procedure before normal operation can resume. DPD should not be enabled using CR software access.

Temperature Compensated Refresh (CR[6:5])
Default = +85°C Operation

The TCR bits allow for adequate refresh at four different temperature thresholds: +15°C, +45°C, +70°C, and +85°C. The setting selected must be for a temperature higher than the case temperature of the CellularRAM device. If the case temperature is +50°C, the system can minimize self refresh current consumption by selecting the +70°C setting. The +15°C and +45°C settings would result in inadequate refreshing and cause data corruption.

Page Mode READ Operation (CR[7])
Default = Disabled

The page mode operation bit determines whether page mode READ operations are enabled. In the power-up default state, page mode is disabled.

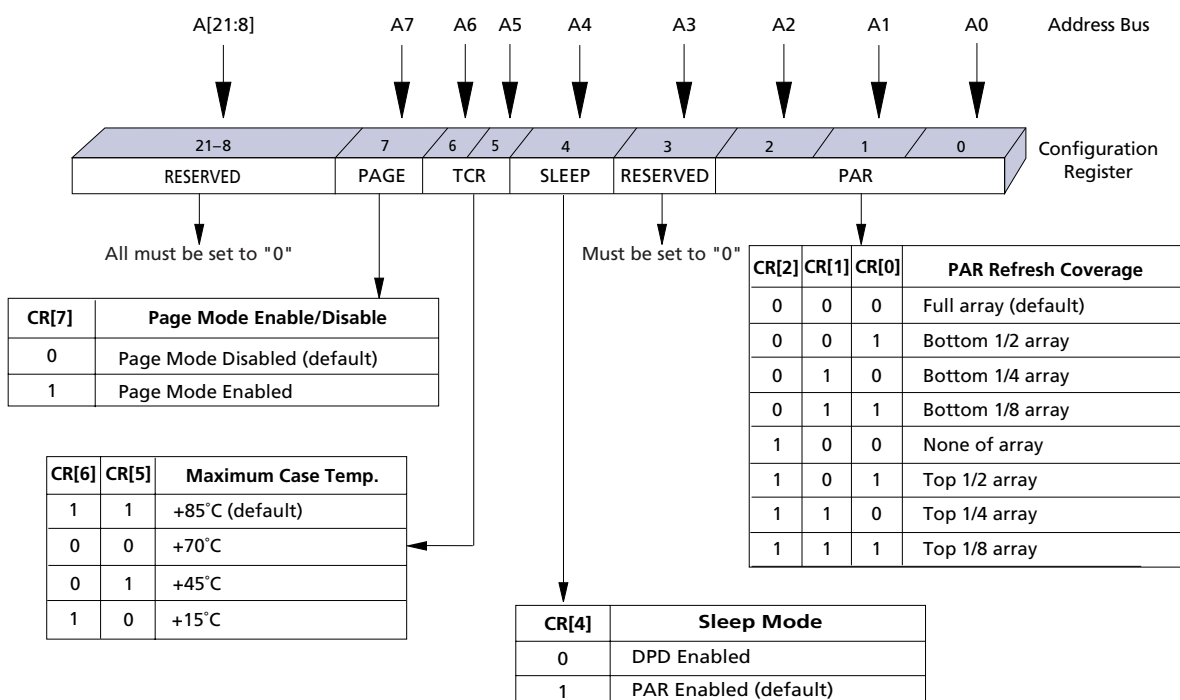
Table 3: Configuration Register Bit Mapping

Table 4: 64Mb Address Patterns for PAR (CR[4] = 1)

| CR[2] | CR[1] | CR[0] | ACTIVE SECTION | ADDRESS SPACE | SIZE | DENSITY |
|-------|-------|-------|--------------------|------------------|------------|---------|
| 0 | 0 | 0 | Full die | 000000h–3FFFFFFh | 4 Meg x 16 | 64Mb |
| 0 | 0 | 1 | One-half of die | 000000h–1FFFFFFh | 2 Meg x 16 | 32Mb |
| 0 | 1 | 0 | One-quarter of die | 000000h–0FFFFFFh | 1 Meg x 16 | 16Mb |
| 0 | 1 | 1 | One-eighth of die | 000000h–07FFFFh | 512K x 16 | 8Mb |
| 1 | 0 | 0 | None of die | 0 | 0 Meg x 16 | 0Mb |
| 1 | 0 | 1 | One-half of die | 200000h–3FFFFFFh | 2 Meg x 16 | 32Mb |
| 1 | 1 | 0 | One-quarter of die | 300000h–3FFFFFFh | 1 Meg x 16 | 16Mb |
| 1 | 1 | 1 | One-eighth of die | 380000h–3FFFFFFh | 512K x 16 | 8Mb |

Table 5: 32Mb Address Patterns for PAR (CR[4] = 1)

| CR[2] | CR[1] | CR[0] | ACTIVE SECTION | ADDRESS SPACE | SIZE | DENSITY |
|-------|-------|-------|--------------------|------------------|------------|---------|
| 0 | 0 | 0 | Full die | 000000h–1FFFFFFh | 2 Meg x 16 | 32Mb |
| 0 | 0 | 1 | One-half of die | 000000h–0FFFFFFh | 1 Meg x 16 | 16Mb |
| 0 | 1 | 0 | One-quarter of die | 000000h–07FFFFh | 512K x 16 | 8Mb |
| 0 | 1 | 1 | One-eighth of die | 000000h–03FFFFh | 256K x 16 | 4Mb |
| 1 | 0 | 0 | None of die | 0 | 0 Meg x 16 | 0Mb |
| 1 | 0 | 1 | One-half of die | 100000h–1FFFFFFh | 1 Meg x 16 | 16Mb |
| 1 | 1 | 0 | One-quarter of die | 180000h–1FFFFFFh | 512K x 16 | 8Mb |
| 1 | 1 | 1 | One-eighth of die | 1C0000h–1FFFFFFh | 256K x 16 | 4Mb |



Absolute Maximum Ratings*

| | |
|--|--|
| Voltage to Any Ball Except VCC, VCCQ | |
| Relative to VSS | -0.50V to (4.0V or VccQ + 0.3V, whichever is less) |
| Voltage on VCC Supply Relative to VSS | -0.20V to 2.45V |
| Voltage on VCCQ Supply Relative to VSS | -0.20V to 4.0V |
| Storage Temperature | -55°C to 150°C |
| Operating Temperature (Case) | |
| Wireless | -25°C to 85°C |
| Industrial | -40°C to 85°C |
| Soldering Temperature and Time | |
| 10s (lead only) | 260°C |

*Stresses greater than those listed under “Absolute Maximum Ratings” may cause permanent damage to the device. This is a stress rating only, and functional operation of the device at these or any other conditions above those indicated in the operational sections of this specification is not implied. Exposure to absolute maximum rating conditions for extended periods may affect reliability.

Table 6: Electrical Characteristics and Operating Conditions

Wireless Temperature (-25°C ≤ T_C ≤ +85 °C)
Industrial Temperature (-40°C < T_C < +85°C)

| DESCRIPTION | CONDITIONS | SYMBOL | MIN | MAX | UNITS | NOTES | |
|--------------------------------|--|-----------------|-------------|------------|-------|-------|---|
| Supply Voltage | | Vcc | 1.70 | 1.95 | V | | |
| I/O Supply Voltage | | VccQ | L: 3.00V | 2.70 | 3.30 | V | |
| | | | V: 2.50V | 2.30 | 2.70 | V | |
| | | | W: 1.80V | 1.70 | 2.25 | V | |
| Input High Voltage | | V _{IH} | 1.4 | VccQ + 0.2 | V | 1 | |
| Input Low Voltage | | V _{IL} | -0.2 | +0.4 | V | 2 | |
| Output High Voltage | I _{OH} = -0.2mA | V _{OH} | 0.80 VccQ | | V | | |
| Output Low Voltage | I _{OL} = 0.2mA | V _{OL} | | 0.20 VccQ | V | | |
| Input Leakage Current | V _{IN} = 0 to VccQ | I _{LI} | | 1 | μA | | |
| Output Leakage Current | OE# = V _{IH} or Chip Disabled | I _{LO} | | 1 | μA | | |
| Operating Current | | | | | | | |
| Asynchronous Random READ/WRITE | V _{IN} = VccQ or 0V Chip Enabled, I _{OUT} = 0 | Icc1 | -70 | | 25 | mA | 3 |
| | | | -85 | | 20 | | |
| Asynchronous Page READ | | Icc1P | -70 | | 15 | mA | 3 |
| | | | -85 | | 12 | | |
| Standby Current | V _{IN} = VccQ or 0V CE# = VccQ | I _{SB} | 64Mb—Std. | | 120 | μA | 4 |
| | | | 64Mb—Opt. L | | 100 | | |
| | | | 32Mb—Std | | 110 | | |
| | | | 32Mb—Opt. L | | 90 | | |

NOTE:

- Input signals may overshoot to VccQ + 1.0V for periods less than 2ns during transitions.
- Input signals may undershoot to Vss - 1.0V for periods less than 2ns during transitions
- This parameter is specified with the outputs disabled to avoid external loading effects. The user must add the current required to drive output capacitance expected in the actual system.
- I_{SB} (MAX) values measured with PAR set to FULL ARRAY and TCR set to +85°C. In order to achieve low standby current, all inputs must be driven to VccQ or Vss. I_{SB} might be slightly higher for up to 500ms after power-up, or after changes to the PAR array partition.

Table 7: Temperature Compensated Refresh Specifications and Conditions

| DESCRIPTION | CONDITIONS | SYMBOL | DENSITY | MAX CASE TEMPERATURES | STANDARD POWER (NO DESIG.) | LOW-POWER OPTION (L) | UNITS |
|---|---------------------------------|--------|---------|-----------------------|----------------------------|----------------------|-------|
| Temperature Compensated Refresh Standby Current | VIN = VccQ or 0V, CE# = VccQ | ITCR | 64Mb | +85°C | 120 | 100 | μA |
| | | | | +70°C | 105 | 85 | μA |
| | | | | +45°C | 85 | 65 | μA |
| | | | | +15°C | 70 | 50 | μA |
| | | | 32Mb | +85°C | 110 | 90 | μA |
| | | | | +70°C | 95 | 75 | μA |
| | | | | +45°C | 80 | 60 | μA |
| | | | | +15°C | 70 | 50 | μA |

NOTE:

ITCR (MAX) values measured with FULL ARRAY refresh.

Table 8: Partial Array Refresh Specifications and Conditions

| DESCRIPTION | CONDITIONS | SYMBOL | DENSITY | ARRAY PARTITION | STANDARD POWER (NO DESIG.) | LOW-POWER OPTION (L) | UNITS |
|-------------------------------|---|--------|---------|-----------------|----------------------------|----------------------|-------|
| Partial Array Refresh Current | VIN = VccQ or 0V ZZ# = 0V CR[4] = 1 | IPAR | 64Mb | Full | 120 | 100 | μA |
| | | | | 1/2 | 115 | 95 | μA |
| | | | | 1/4 | 110 | 90 | μA |
| | | | | 1/8 | 105 | 85 | μA |
| | | | | 0 | 70 | 50 | μA |
| | | | 32Mb | Full | 110 | 90 | μA |
| | | | | 1/2 | 105 | 85 | μA |
| | | | | 1/4 | 100 | 80 | μA |
| | | | | 1/8 | 95 | 75 | μA |
| | | | | 0 | 70 | 50 | μA |

NOTE:

IPAR (MAX) values measured with TCR set to 85°C. IPAR might be slightly higher for up to 500ms after changes to the PAR array partition.

Table 9: Deep Power-Down Specifications and Conditions

| DESCRIPTION | CONDITIONS | SYMBOL | TYP | UNITS |
|-----------------|--|--------|-----|-------|
| Deep Power-Down | VIN = VccQ or 0V; +25°C ZZ# = 0V CR[4] = 0 | Izz | 10 | μA |

Table 10: Capacitance Specifications and Conditions

| DESCRIPTION | CONDITIONS | SYMBOL | MIN | MAX | UNITS | NOTES |
|-------------------------------|---|----------|-----|-----|-------|-------|
| Input Capacitance | $T_C = +25^\circ\text{C}; f = 1 \text{ MHz};$ | C_{IN} | 2.0 | 6 | pF | 1 |
| Input/Output Capacitance (DQ) | $V_{IN} = 0V$ | C_{IO} | 3.5 | 6 | pF | 1 |

NOTE:

1. These parameters are verified in device characterization and are not 100% tested.

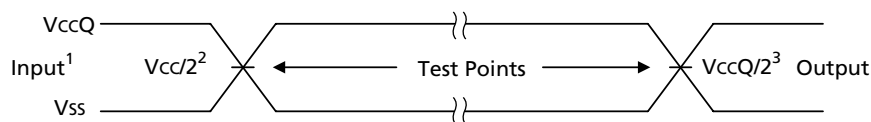
Figure 12: AC Input/Output Reference Waveform

NOTE:

1. AC test inputs are driven at V_{CCQ} for a logic 1 and V_{SS} for a logic 0. Input rise and fall times (10% to 90%) < 1.6ns.
2. Input timing begins at $V_{CC}/2$. Due to the possibility of a difference between V_{CC} and V_{CCQ} , the input test point may not be shown to scale.
3. Output timing ends at $V_{CCQ}/2$.

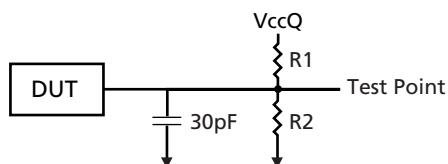
Figure 13: Output Load Circuit

Table 11: Output Load Circuit

| V_{CCQ} | $R1/R2$ |
|-----------|---------------|
| 1.8V | 2.7K Ω |
| 2.5V | 3.7K Ω |
| 3.0V | 4.5K Ω |

Table 12: READ Cycle Timing Requirements

| PARAMETER | SYMBOL | -70 | | -85 | | UNITS | NOTES |
|----------------------------------|------------------|-----|-----|-----|-----|-------|-------|
| | | MIN | MAX | MIN | MAX | | |
| Address Access Time | t _{AA} | | 70 | | 85 | ns | |
| Page Access Time | t _{APA} | | 20 | | 25 | ns | |
| LB#/UB# Access Time | t _{BA} | | 70 | | 85 | ns | |
| LB#/UB# Disable to High-Z Output | t _{BHZ} | | 8 | | 8 | ns | 2 |
| LB#/UB# Enable to Low-Z Output | t _{BLZ} | 10 | | 10 | | ns | 1 |
| Maximum CE# Pulse Width | t _{CEM} | | 8 | | 8 | μs | 3 |
| Chip Select Access Time | t _{CO} | | 70 | | 85 | ns | |
| Chip Disable to High-Z Output | t _{HZ} | | 8 | | 8 | ns | 2 |
| Chip Enable to Low-Z Output | t _{LZ} | 10 | | 10 | | ns | 1 |
| Output Enable to Valid Output | t _{OE} | | 20 | | 20 | ns | |
| Output Hold from Address Change | t _{OH} | 5 | | 5 | | ns | |
| Output Disable to High-Z Output | t _{OHZ} | | 8 | | 8 | ns | 2 |
| Output Enable to Low-Z Output | t _{OLZ} | 5 | | 5 | | ns | 1 |
| Page Cycle Time | t _{PC} | 20 | | 25 | | ns | |
| Read Cycle Time | t _{RC} | 70 | | 85 | | ns | |

Table 13: WRITE Cycle Timing Requirements

| PARAMETER | SYMBOL | -70 | | -85 | | UNITS | NOTES |
|-------------------------------|------------------|-----|-----|-----|-----|-------|-------|
| | | MIN | MAX | MIN | MAX | | |
| Address Setup Time | t _{AS} | 0 | | 0 | | ns | |
| Address Valid to End of Write | t _{AW} | 70 | | 85 | | ns | |
| Byte Select to End of Write | t _{BW} | 70 | | 85 | | ns | |
| CE# HIGH Time During Write | t _{CEH} | 5 | | 5 | | ns | |
| Chip Enable to End of Write | t _{CW} | 70 | | 85 | | ns | |
| Data Hold from Write Time | t _{DH} | 0 | | 0 | | ns | |
| Data Write Setup Time | t _{DW} | 23 | | 25 | | ns | |
| Chip Enable to Low-Z Output | t _{LZ} | 10 | | 10 | | ns | 1 |
| End Write to Low-Z Output | t _{OW} | 5 | | 5 | | ns | |
| Write Cycle Time | t _{WC} | 70 | | 85 | | ns | |
| Write to High-Z Output | t _{WHZ} | | 8 | | 8 | ns | 2 |
| Write Pulse Width | t _{WP} | 46 | | 50 | | ns | 4 |
| Write Pulse Width HIGH | t _{WPH} | 10 | | 10 | | ns | |
| Write Recovery Time | t _{WR} | 0 | | 0 | | ns | |

NOTE:

- High-Z to Low-Z timings are tested with the circuit shown in Figure 13 on page 14. The Low-Z timings measure a 100mV transition away from the High-Z (V_{CCQ/2}) level toward either V_{OH} or V_{OL}.
- Low-Z to High-Z timings are tested with the circuit shown in Figure 13 on page 14. The High-Z timings measure a 100mV transition from either V_{OH} or V_{OL} toward V_{CCQ/2}.
- Page-mode enabled only.
- WE# LOW time must be limited to t_{CEM} (8μ).

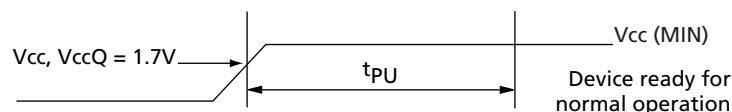

Table 14: Load Configuration Register Timing Requirements

| DESCRIPTION | SYMBOL | -70 | | -85 | | UNITS | NOTES |
|-------------------------------|------------|-----|-----|-----|-----|-------|-------|
| | | MIN | MAX | MIN | MAX | | |
| Address Setup Time | t_{AS} | 0 | | 0 | | ns | |
| Address Valid to End of Write | t_{AW} | 70 | | 85 | | ns | |
| Chip Deselect to ZZ# LOW | t_{CDZZ} | 5 | | 5 | | ns | |
| Chip Enable to End of Write | t_{CW} | 70 | | 85 | | ns | |
| Write Cycle Time | t_{WC} | 70 | | 85 | | ns | |
| Write Pulse Width | t_{WP} | 40 | | 40 | | ns | |
| Write Recovery Time | t_{WR} | 0 | | 0 | | ns | |
| ZZ# LOW to WE# LOW | t_{ZZWE} | 10 | 500 | 10 | 500 | ns | |

Table 15: Deep Power-Down Timing Requirements

| DESCRIPTION | SYMBOL | -70 | | -85 | | UNITS | NOTES |
|--------------------------|-------------|-----|-----|-----|-----|---------|-------|
| | | MIN | MAX | MIN | MAX | | |
| Chip Deselect to ZZ# LOW | t_{CDZZ} | 5 | | 5 | | ns | |
| Deep Power-Down Recovery | t_R | 150 | | 150 | | μ s | |
| Minimum ZZ# Pulse Width | t_{ZZMIN} | 10 | | 10 | | μ s | |

TIMING DIAGRAMS

Figure 14: Power-Up Initialization Period

Table 16: Power-Up Initialization Timing Requirements

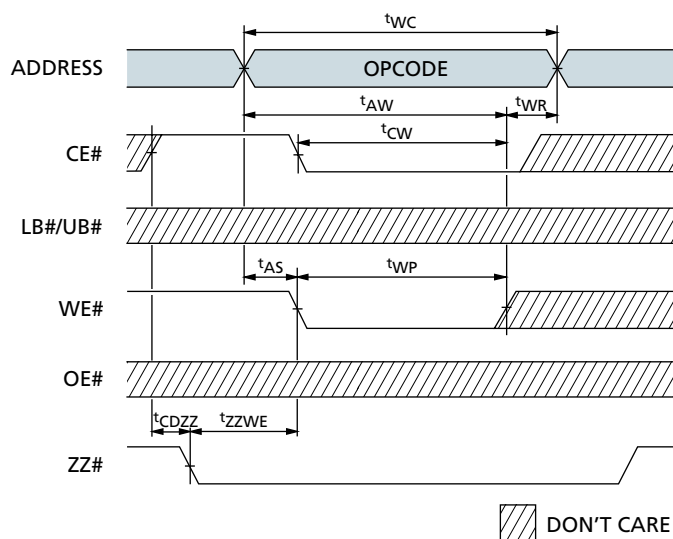
| PARAMETER | SYMBOL | -70 | | -85 | | UNITS | NOTES |
|--------------------------------|----------|-----|-----|-----|-----|---------|-------|
| | | MIN | MAX | MIN | MAX | | |
| Power-Up Initialization Period | t_{PU} | 150 | | 150 | | μ s | |

Figure 15: Load Configuration Register

Table 17: Load Configuration Register Timing Requirements

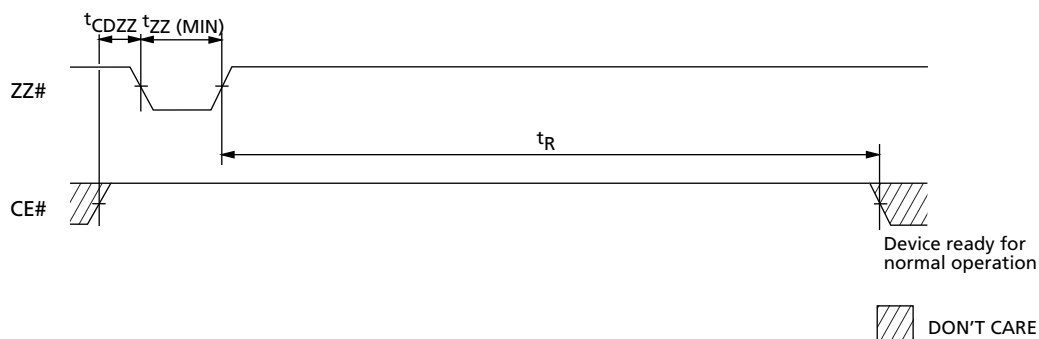
| SYMBOL | -70 | | -85 | | UNITS |
|------------|-----|-----|-----|-----|-------|
| | MIN | MAX | MIN | MAX | |
| t_{AS} | 0 | | 0 | | ns |
| t_{AW} | 70 | | 85 | | ns |
| t_{CDZZ} | 5 | | 5 | | ns |
| t_{CW} | 70 | | 85 | | ns |

| SYMBOL | -70 | | -85 | | UNITS |
|------------|-----|-----|-----|-----|-------|
| | MIN | MAX | MIN | MAX | |
| t_{WC} | 70 | | 85 | | ns |
| t_{WP} | 40 | | 40 | | ns |
| t_{WR} | 0 | | 0 | | ns |
| t_{ZZWE} | 10 | 500 | 10 | 500 | ns |

Figure 16: Deep Power-Down—Entry/Exit

Table 18: Deep Power-Down Timing Parameters

| SYMBOL | -70 | | -85 | | UNITS |
|----------------|-----|-----|-----|-----|---------|
| | MIN | MAX | MIN | MAX | |
| t_{CDZZ} | 5 | | 5 | | ns |
| t_R | 150 | | 150 | | μ s |
| $t_{ZZ} (MIN)$ | 10 | | 10 | | μ s |



4 MEG x 16, 2 MEG x 16
ASYNC/PAGE CellularRAM MEMORY

Figure 17: Single READ Operation (WE# = VIH)

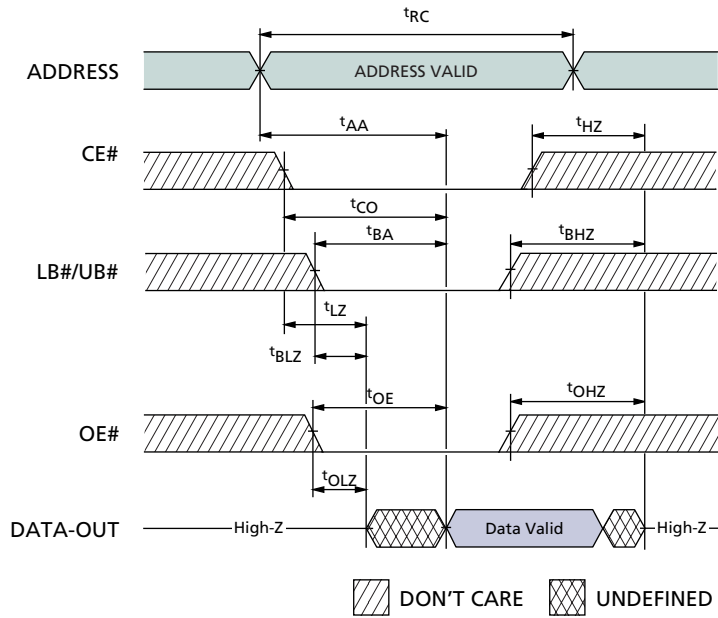
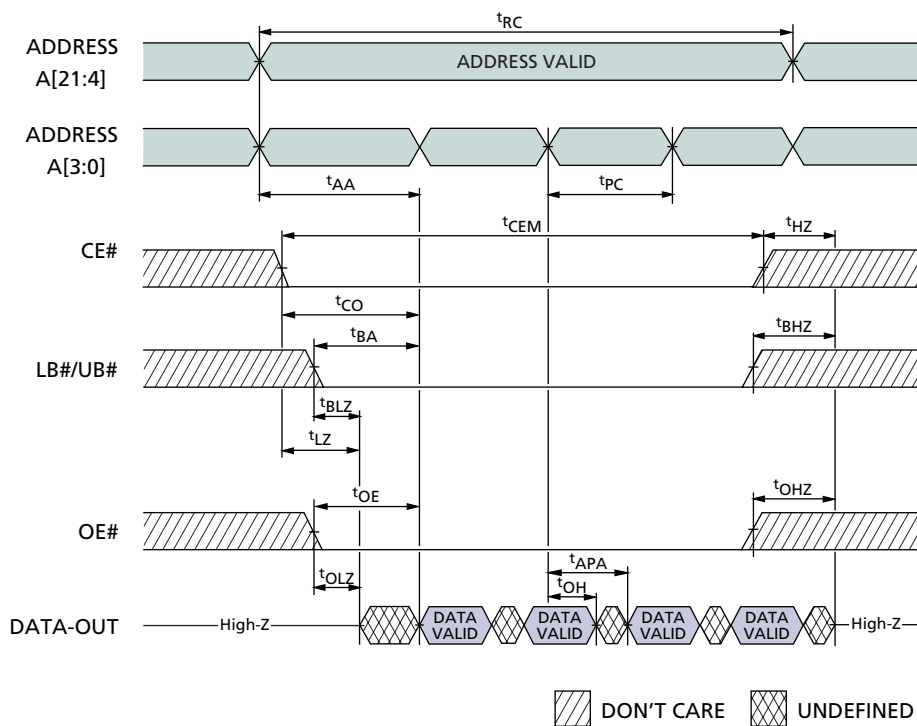

Table 19: READ Timing Parameters

| SYMBOL | -70 | | -85 | | UNITS |
|------------------|-----|-----|-----|-----|-------|
| | MIN | MAX | MIN | MAX | |
| t _{AA} | | 70 | | 85 | ns |
| t _{BA} | | 70 | | 85 | ns |
| t _{BHZ} | | 8 | | 8 | ns |
| t _{BLZ} | 10 | | 10 | | ns |
| t _{CO} | | 70 | | 85 | ns |
| t _{HZ} | | 8 | | 8 | ns |

| SYMBOL | -70 | | -85 | | UNITS |
|------------------|-----|-----|-----|-----|-------|
| | MIN | MAX | MIN | MAX | |
| t _{LZ} | 10 | | 10 | | ns |
| t _{OE} | | 20 | | 20 | ns |
| t _{OHZ} | | 8 | | 8 | ns |
| t _{OLZ} | 5 | | 5 | | ns |
| t _{RC} | 70 | | 85 | | ns |

Figure 18: Page Mode READ Operation (WE# = VIH)

Table 20: Page Mode READ Timing Parameters

| SYMBOL | -70 | | -85 | | UNITS |
|-----------|-----|-----|-----|-----|---------|
| | MIN | MAX | MIN | MAX | |
| t_{AA} | | 70 | | 85 | ns |
| t_{APA} | | 20 | | 25 | ns |
| t_{BA} | | 70 | | 85 | ns |
| t_{BHZ} | | 8 | | 8 | ns |
| t_{BLZ} | 10 | | 10 | | ns |
| t_{CEM} | | 8 | | 8 | μ s |
| t_{CO} | | 70 | | 85 | ns |
| t_{HZ} | | 8 | | 8 | ns |

| SYMBOL | -70 | | -85 | | UNITS |
|-----------|-----|-----|-----|-----|-------|
| | MIN | MAX | MIN | MAX | |
| t_{LZ} | 10 | | 10 | | ns |
| t_{OE} | | 20 | | 20 | ns |
| t_{OH} | 5 | | 5 | | ns |
| t_{OHZ} | | 8 | | 8 | ns |
| t_{OLZ} | 5 | | 5 | | ns |
| t_{PC} | 20 | | 25 | | ns |
| t_{RC} | 70 | | 85 | | ns |



Figure 19: WRITE Cycle (WE# Control)

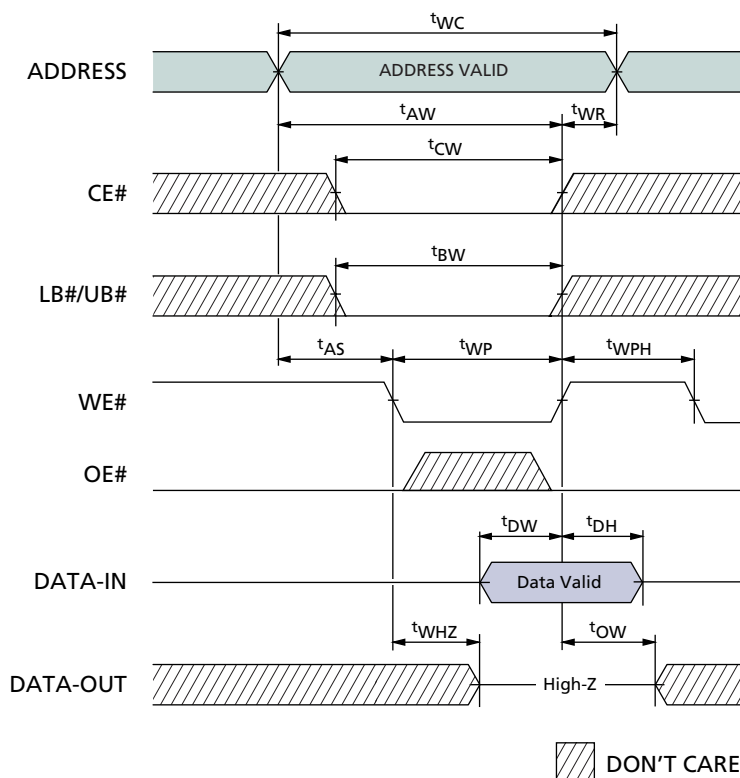
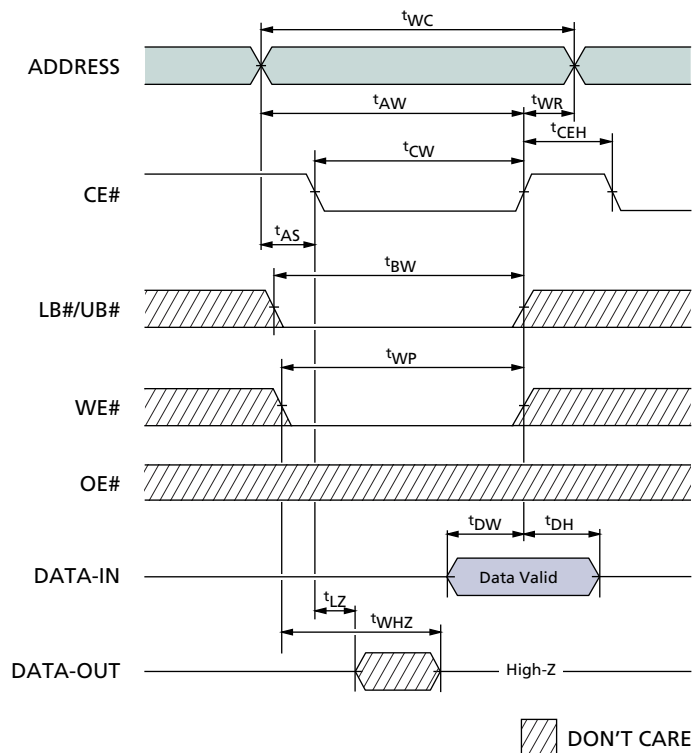

Table 21: WRITE Timing Parameters

| SYMBOL | -70 | | -85 | | UNITS |
|----------|-----|-----|-----|-----|-------|
| | MIN | MAX | MIN | MAX | |
| t_{AS} | 0 | | 0 | | ns |
| t_{AW} | 70 | | 85 | | ns |
| t_{BW} | 70 | | 85 | | ns |
| t_{CW} | 70 | | 85 | | ns |
| t_{DH} | 0 | | 0 | | ns |
| t_{DW} | 23 | | 25 | | ns |

| SYMBOL | -70 | | -85 | | UNITS |
|-----------|-----|-----|-----|-----|-------|
| | MIN | MAX | MIN | MAX | |
| t_{OW} | 5 | | 5 | | ns |
| t_{WC} | 70 | | 85 | | ns |
| t_{WHZ} | | 8 | | 8 | ns |
| t_{WP} | 46 | | 50 | | ns |
| t_{WPH} | 10 | | 10 | | ns |
| t_{WR} | 0 | | 0 | | ns |

Figure 20: WRITE Cycle (CE# Control)

Table 22: WRITE Timing Parameters

| SYMBOL | -70 | | -85 | | UNITS |
|------------------|-----|-----|-----|-----|-------|
| | MIN | MAX | MIN | MAX | |
| t _{AS} | 0 | | 0 | | ns |
| t _{AW} | 70 | | 85 | | ns |
| t _{BW} | 70 | | 85 | | ns |
| t _{CEH} | 5 | | 5 | | ns |
| t _{CW} | 70 | | 85 | | ns |
| t _{DH} | 0 | | 0 | | ns |

| SYMBOL | -70 | | -85 | | UNITS |
|------------------|-----|-----|-----|-----|-------|
| | MIN | MAX | MIN | MAX | |
| t _{DW} | 23 | | 25 | | ns |
| t _{LZ} | 10 | | 10 | | ns |
| t _{WC} | 70 | | 85 | | ns |
| t _{WHZ} | | 8 | | 8 | ns |
| t _{WP} | 46 | | 50 | | ns |
| t _{WR} | 0 | | 0 | | ns |



Figure 21: WRITE Cycle (LB#/UB# Control)

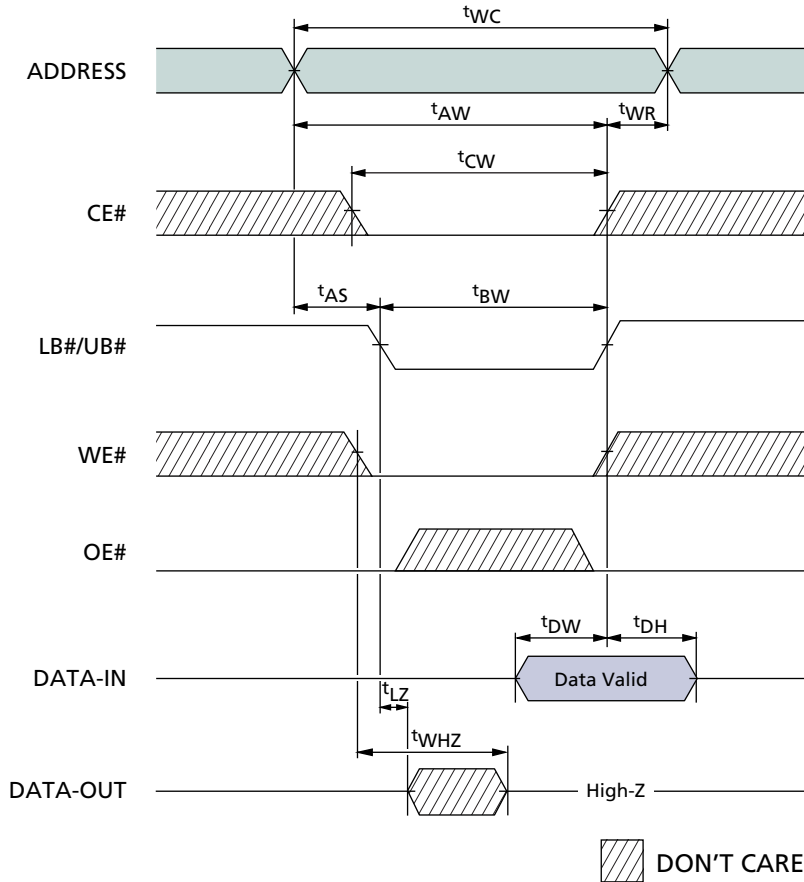

Table 23: WRITE Timing Parameters

| SYMBOL | -70 | | -85 | | UNITS |
|-----------------|-----|-----|-----|-----|-------|
| | MIN | MAX | MIN | MAX | |
| t _{AS} | 0 | | 0 | | ns |
| t _{AW} | 70 | | 85 | | ns |
| t _{BW} | 70 | | 85 | | ns |
| t _{CW} | 70 | | 85 | | ns |
| t _{DH} | 0 | | 0 | | ns |

| SYMBOL | -70 | | -85 | | UNITS |
|------------------|-----|-----|-----|-----|-------|
| | MIN | MAX | MIN | MAX | |
| t _{DW} | 23 | | 25 | | ns |
| t _{LZ} | 10 | | 10 | | ns |
| t _{WC} | 70 | | 85 | | ns |
| t _{WHZ} | | 8 | | 8 | ns |
| t _{WR} | 0 | | 0 | | ns |



Figure 22: 48-Ball VFBGA

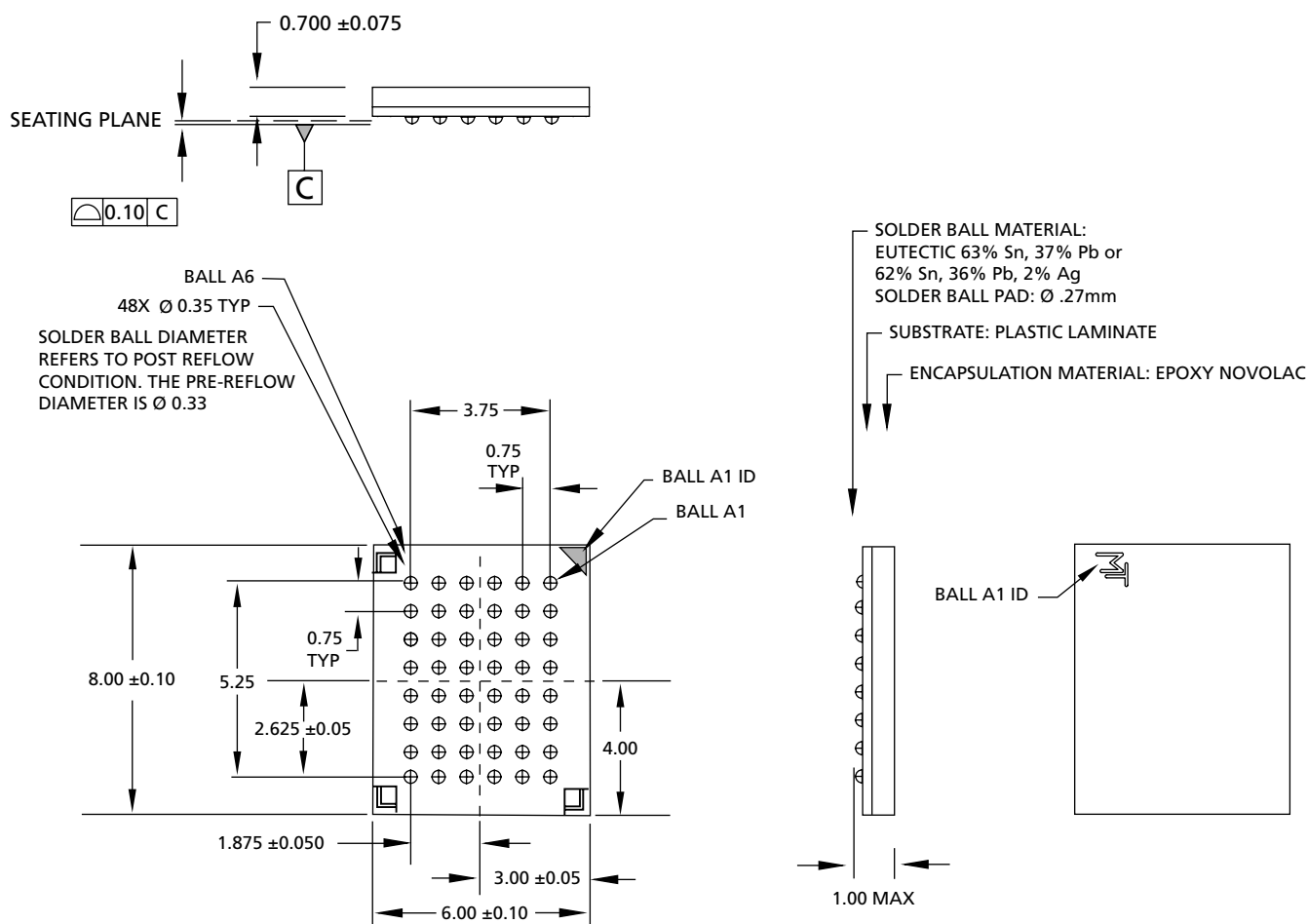

NOTE:

1. All dimensions in millimeters, MAX/MIN or typical where noted.
2. Package width and length do not include mold protrusion; allowable mold protrusion is 0.25mm per side.

Data Sheet Designation: PRELIMINARY

This data sheet contains initial characterization limits, subject to change upon full characterization of production devices.



8000 S. Federal Way, P.O. Box 6, Boise, ID 83707-0006, Tel: 208-368-3900

E-mail: prodmktg@micron.com, Internet: <http://www.micron.com>, Customer Comment Line: 800-932-4992

Micron, and the Micron and M Logos are trademarks and/or service marks of Micron Technology, Inc.

CellularRAM is a trademark of Micron Technology, Inc., inside the U.S. and a trademark of Infineon Technologies outside the U.S.

All other trademarks are the property of their respective owners.

Revision History

| | |
|--|---|
| Rev. C, Preliminary | 5/04 |
| <ul style="list-style-type: none"> • Clarified CE# LOW time limited by refresh—must not stay LOW longer than t_{CEM}. • Added software access. • Changed t_{CEM} MAX to 8. • Clarified address A[4] and higher in page mode. • Clarified ICC and updated symbols. • Changed PAR options to full, one-half, one-quarter, one-eighth, or none. | <ul style="list-style-type: none"> • Deleted Appendix A (extended timings and all references). • Added C_{IN} and C_{IO} MIN values. • Replaced Abbreviated Component Marks with Part Numbering chart. • Added measurement time clarification to ISB and IPAR notes • Corrected package nomenclature to VFBGA. |
| Rev. B, Preliminary | 12/03 |
| <ul style="list-style-type: none"> • Prohibited DPD via software access. • Updated Appendix regarding Async page mode. • Added t_{WPH}, t_{CEM}, and t_{CW} to tables and figures where not already appropriately represented. | <ul style="list-style-type: none"> • Added “Access Using ZZ#” section. • Added software access section. • Added standard and low-power data in tables 8 & 9. • V, IT, and -60 now “contact factory.” |
| Rev. A, Preliminary | 7/03 |
| <ul style="list-style-type: none"> • Input/Output leakage to 1μA. • Added Industrial Temperature. | <ul style="list-style-type: none"> • Changed standby power to 90μA and 100μA. • Changed Input High Voltage MAX to V_{CCQ} + 0.2. |