

The Power  
of Melcher.

# DC-DC Converters



Power [W]	Output [V DC]						No. of outputs	Input [V DC]						Series
	3	5	15	24	36	48		3	10	20	60	80	180	
<b>Print Mountable</b>														
1	██████████						1,2	█						DSP
1...12	██████████						1, 2, 3	██████████						IMP
2.4	█						1	█						CHS
3	██████████						1,2	██████████						IXP
3...15	██████████						1, 2, 3	██████████						IMR
4	██████████						1, 2	██████████						IMX 4
6	████						1,2	██████████						IMO
6...20	████						1,2	██████████						DFA
6...30	████						1,2,3	██████████						DFC
7	██████████						1, 2	██████████						IMS 7
7	██████████						1, 2	██████████						IMX 7
10	██████████						1, 2	██████████						IML
10...30	██████████						1, 2, 3	██████████						DGP
15	██████████						1, 2	██████████						IMS 15
15	██████████						1, 2	██████████						IMX 15, IMY 15
25	████						1, 2	██████████						OBS, OBD
25/40	██████████						1, 2, 3	██████████						IMR 25, IMR 40
<b>Cassette Style</b>														
20	██████████						1	██████████						SR
50	██████████						1, 2, 3	██████████						H
50	██████████						1, 2, 3	██████████						M
100...150	██████████						1, 2	██████████						Q
100	██████████						1, 2	██████████						S
150	██████████						1, 2	██████████						K
<b>Open Frame</b>														
150	████						3, 4	█						MDU
<b>Bricks</b>														
15...60	██████████						1	██████████						HAS
25...150	████						1	█						HES
33...100	██████████						1	██████████						HBS
38...66	█						1	██████████						QES
38...150	██████████						1	██████████						QBS
50...60	██████████						1	█						QAS
100...190	██████████						1	██████████						XWS
100...300	████						1	█						FES
100...300	██████████						1	██████████						VWS
113...225	████						1	██████████						TES

Comprehensive data sheets are available from either source:

- Internet: [www.melcher.ch](http://www.melcher.ch)
- Melcher CD-ROM
- Melcher Databook
- Nearest sales office by fax or mail.

# 120/180 Watt DC-DC Converters

# P Series

Preliminary

**Input to output isolation**

- Single output: 3.3, 5.1 V DC**
- Double output: 3.3/5.1, 2 x 5.1, 2 x 12, 2 x 15, 2 x 24 V**
- Triple output: 5.1/ 2 x 12, 5.1/ 2 x 15 V DC**
- Quadruple output: 5.1/3.3 with 2 x 12, 2 x 24 with 2 x 24 V DC**

- Extremely high efficiency
- Flex power: Flexible load distribution
- Excellent surge and transient protection
- 4242 V DC input to output electric strength test
- Redundant operation (n+1), current sharing option
- Extremely low inrush current, hot plug-in
- Externally adjustable output voltage
- Inhibit primary or secondary referenced
- Very compact and fully functional unit (20 mm wide)
- Telecoms compatible input voltage range of DP units according to prETS 300132-2 (40...101 V DC)

Safety according to IEC/EN 60950, UL 1950

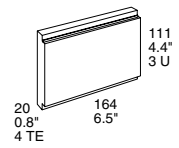
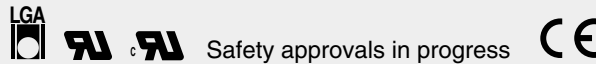

## Summary

These extremely compact DC-DC converters incorporate all necessary input and output filtering, signalling and protection features which according to the latest industry standards are required in the majority of applications. The converters provide important advantages such as flexible output power through primary current limitation, extremely high efficiency, excellent reliability, very low ripple and RFI noise levels, full input to output isolation, negligible inrush current, soft start, overtemperature protection and input over-/undervoltage lock-out. The converter inputs are protected against surges and transients occurring on the source lines, covering a total input voltage range from 16 V DC up to 150 V DC with five different types.

The outputs are continuously open- and short-circuit proof. LEDs at the front panel and an isolated output power good option indicate the status of the power supply modules. Voltage suppressor diodes protect the outputs against an internally generated overvoltage.

Full system flexibility and n+1 redundant operating mode are possible due to virtually unrestricted series or parallel connection capabilities of all outputs. In parallel connection

of several units, current sharing option is provided by a single wire interconnection.

As a modular power supply or as part of a distributed power supply system, the low profile design significantly reduces the necessary power supply volume without sacrificing high reliability.

The units are designed as forward converters using planar magnetics and control circuits in hybrid technology. The switching frequency is fix at 307 kHz under normal operating conditions. Triple and quadruple output modules have their voltage regulation of output 3 and 4 relying on the close magnetic coupling of transformer and output conductor together with the circuit symmetry of their main outputs 2, respectively 1. Outputs with an equal output voltage can either be series or parallel connected.

The fully enclosed, black coated aluminium case acts as heat sink and RFI shield. It is particularly suitable for 19" rack systems occupying 3U/4TE only, but can also be chassis-mounted by means of four M3 screws. Connector type is H15 and for single output modules H15 S2.

## Table of Contents

Table of Contents	Page	Page	
Summary .....	1	Mechanical Data .....	5
Type Survey and Key Data .....	2	Safety and Installation Instructions .....	6
Type Key and Product Marking .....	4		

## Type Survey and Key Data

Table 1a: Type survey BP, CP

Output 1, 4 <sup>3</sup>			Output 2, 3 <sup>3</sup>			Input voltage range and efficiency <sup>2</sup>			Options	
$U_{o\ nom}$ [V DC]	$T_A = 50^\circ\text{C}$ $P_{o\ max}$ [W]	$T_A = 71^\circ\text{C}$ $P_{o\ nom}$ [W]	$U_{o\ nom}$ [V DC]	$T_A = 50^\circ\text{C}$ $P_{o\ max}$ [W]	$T_A = 71^\circ\text{C}$ $P_{o\ nom}$ [W]	$\eta_{min}$ [%]	$U_{i\ min...U_{i\ max}}$ <sup>4</sup> <b>16...36 V DC</b>	$\eta_{min}$ [%]		$U_{i\ min...U_{i\ max}}$ <sup>4</sup> <b>33.6...75 V DC</b>
3.3	125	106	-	-	-		BP 1101-7R		CP 1101-7R	-9 D V <sup>6</sup> G T <sup>6</sup> i W
5.1	152	122	-	-	-		BP 1001-7R		CP 1001-7R	
3.3	62	53	5.1	76	61		BP 2101-7R		CP 2101-7R	
5.1	76	61	5.1	76	61		BP 2001-7R		CP 2001-7R	
12	90	72	12	90	72		BP 2320-7R		CP 2320-7R	
15	82	60	15	82	60		BP 2540-7R		CP 2540-7R	
24	84	60	24	84	60		BP 2660-7R		CP 2660-7R	
5.1	76	61	12, 12	72 <sup>1</sup>	60 <sup>1</sup>		BP 3020-7R		CP 3020-7R	
5.1	76	61	15, 15	75 <sup>1</sup>	60 <sup>1</sup>		BP 3040-7R		CP 3040-7R	
5.1, 3.3 <sup>5</sup>	50 <sup>1</sup>	40 <sup>1</sup>	12, 12	72 <sup>1</sup>	60 <sup>1</sup>		BP 4720-7R		CP 4720-7R	
24, 24	84 <sup>1</sup>	60 <sup>1</sup>	24, 24	84 <sup>1</sup>	60 <sup>1</sup>		BP 4660-7R		CP 4660-7R	

Table 1b: Type survey DP, EP

Output 1, 4 <sup>3</sup>			Output 2, 3 <sup>3</sup>			Input voltage range and efficiency <sup>2</sup>			Options	
$U_{o\ nom}$ [V DC]	$T_A = 50^\circ\text{C}$ $P_{o\ max}$ [W]	$T_A = 71^\circ\text{C}$ $P_{o\ nom}$ [W]	$U_{o\ nom}$ [V DC]	$T_A = 50^\circ\text{C}$ $P_{o\ max}$ [W]	$T_A = 71^\circ\text{C}$ $P_{o\ nom}$ [W]	$\eta_{min}$ [%]	$U_{i\ min...U_{i\ max}}$ <sup>4</sup> <b>40...101 V DC</b>	$\eta_{min}$ [%]		$U_{i\ min...U_{i\ max}}$ <sup>4</sup> <b>66...150 V DC</b>
3.3	125	106	-	-	-		DP 1101-7R		EP 1101-7R	-9 D V <sup>6</sup> G T <sup>6</sup> i W
5.1	152	122	-	-	-		DP 1001-7R		EP 1001-7R	
3.3	62	53	5.1	76	61		DP 2101-7R		EP 2101-7R	
5.1	76	61	5.1	76	61		DP 2001-7R		EP 2001-7R	
12	90	72	12	90	72		DP 2320-7R		EP 2320-7R	
15	82	60	15	82	60		DP 2540-7R		EP 2540-7R	
24	84	60	24	84	60		DP 2660-7R		EP 2660-7R	
5.1	76	61	12, 12	72 <sup>1</sup>	60 <sup>1</sup>		DP 3020-7R		EP 3020-7R	
5.1	76	61	15, 15	75 <sup>1</sup>	60 <sup>1</sup>		DP 3040-7R		EP 3040-7R	
5.1, 3.3 <sup>5</sup>	50 <sup>1</sup>	40 <sup>1</sup>	12, 12	72 <sup>1</sup>	60 <sup>1</sup>		DP 4720-7R		EP 4720-7R	
24, 24	84 <sup>1</sup>	60 <sup>1</sup>	24, 24	84 <sup>1</sup>	60 <sup>1</sup>		DP 4660-7R		EP 4660-7R	

Table 1c: Type survey GP

Output 1, 4 <sup>3</sup>			Output 2, 3 <sup>3</sup>			Input voltage range and efficiency <sup>2</sup>			Options
$U_{o\ nom}$ [V DC]	$T_A = 50^\circ\text{C}$ $P_{o\ max}$ [W]	$T_A = 71^\circ\text{C}$ $P_{o\ nom}$ [W]	$U_{o\ nom}$ [V DC]	$T_A = 50^\circ\text{C}$ $P_{o\ max}$ [W]	$T_A = 71^\circ\text{C}$ $P_{o\ nom}$ [W]	$\eta_{min}$ [%]	$U_{i\ min...U_{i\ max}}$ <b>19.2...57.6 V DC</b>		
3.3	100	80	-	-	-		GP 1101-7R		-9 D V <sup>6</sup> G T <sup>6</sup> i W
5.1	120	92	-	-	-		GP 1001-7R		
3.3	50	40	5.1	60	46		GP 2101-7R		
5.1	60	46	5.1	60	46		GP 2001-7R		
12	72	54	12	72	54		GP 2320-7R		
15	68	50	15	68	50		GP 2540-7R		
24	70	48	24	70	48		GP 2660-7R		
5.1	60	46	12, 12	66 <sup>1</sup>	48 <sup>1</sup>		GP 3020-7R		
5.1	60	46	15, 15	68 <sup>1</sup>	50 <sup>1</sup>		GP 3040-7R		
5.1, 3.3 <sup>5</sup>	40 <sup>1</sup>	30 <sup>1</sup>	12, 12	66 <sup>1</sup>	48 <sup>1</sup>		GP 4720-7R		
24, 24	70 <sup>1</sup>	48 <sup>1</sup>	24, 24	70 <sup>1</sup>	48 <sup>1</sup>		GP 4660-7R		

<sup>1</sup> The cumulated power of both outputs may not exceed the total power for the specified ambient temperature.

<sup>2</sup> Minimum efficiency at  $U_{i\ nom}$ ,  $P_{o\ nom}$  and  $T_A = 25^\circ\text{C}$

<sup>3</sup> Output configuration with second output semi-regulated ( $\pm 5\%$   $U_{o\ nom}$  if each output is loaded with  $\geq 5\%$   $P_{o\ nom}$ ). Parallel or series configuration possible.

<sup>4</sup> Short deviations of  $U_{i\ min}/U_{i\ max}$  according to EN 50155 possible.

<sup>5</sup> Internal common ground.

<sup>6</sup> Not available for all types.

**Output Configuration**

The P unit design allows high flexibility in output configuration to cover almost every individual requirement, by simply wiring the separated outputs in parallel, series or independent configurations as per following figures. Parallel and series operation of several modules with equal output voltage is possible also.

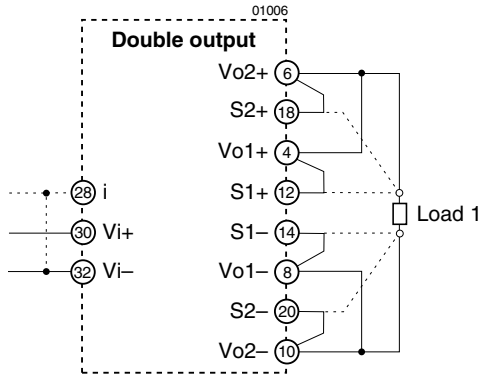

Fig. 1  
Parallel output configuration

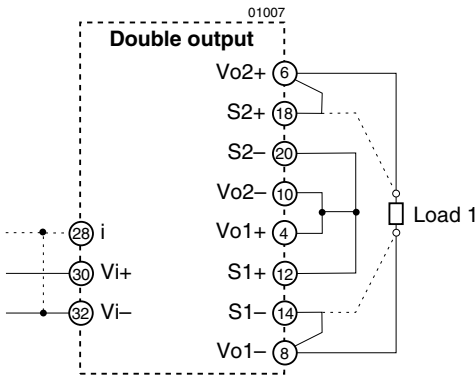

Fig. 2  
Series output configuration

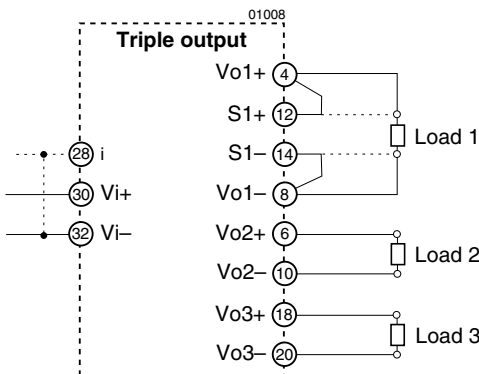

Fig. 3  
Independent output configuration (all outputs)

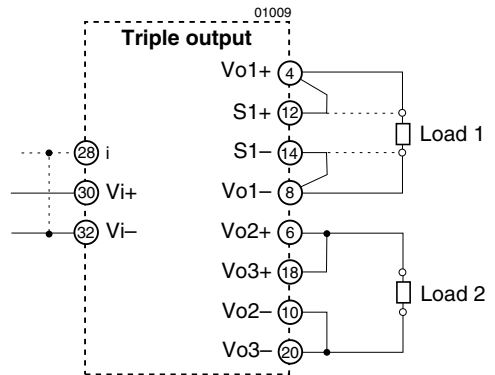

Fig. 4  
Parallel configuration of output 2 and 3

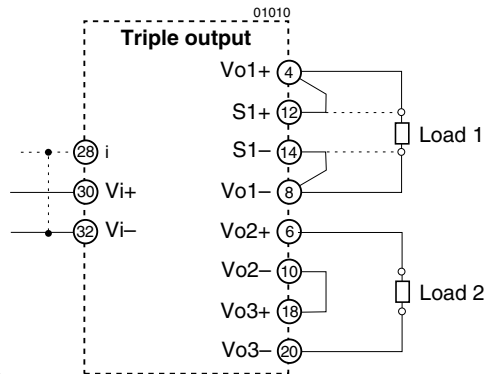

Fig. 5  
Series configuration of output 2 and 3

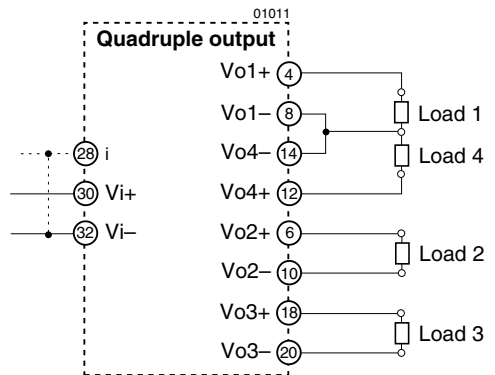

Fig. 6  
Common ground configuration of output 1 with 4 and independent configuration of output 2 and 3

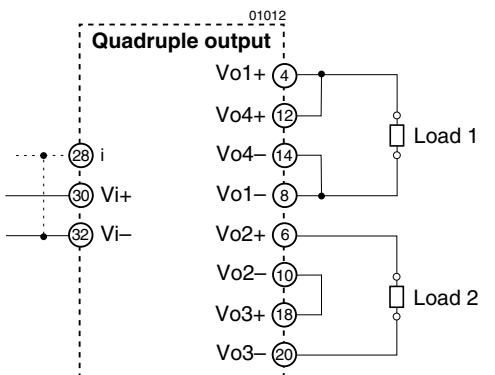

Fig. 7  
Parallel configuration of output 1 with 4 and series configuration of output 2 with 3

Preliminary

## Type Key and Product Marking

### Type Key

	C	P	2	5	40	-7	R	D	V	G	T	i	W
Input voltage range $U_i$ :													
16...36 V DC .....													
33.6...75 V DC .....													
40...101 V DC .....													
66...150 V DC .....													
19.2...57.6 V DC .....													
Series .....													
Number of outputs:													
Single output .....													
Double output .....													
Triple output .....													
Quadruple output .....													
Nominal voltage output 1/output 4, $U_{o1/4 \text{ nom}}$ :													
5.1 V .....													
3.3 V .....													
12 V .....													
15 V .....													
24 V .....													
5.1/3.3 V .....													
other voltages .....													
Other specifications for main output .....													
Nominal voltage output 2/output 3, $U_{o2/3 \text{ nom}}$ :													
5.1 V .....													
12 V .....													
15 V .....													
24 V .....													
other voltages .....													
Operational ambient temperature range $T_A$ :													
-25...71 °C .....													
-40...71 °C (option) .....													
customer specific .....													
Output voltage control input (auxiliary function) .....													
Options:													
Out OK output .....													
VME compatible monitoring circuit .....													
Second control loop (OVP) .....													
Current sharing .....													
Isolated inhibit on secondary side .....													
Synchronisation of switching frequency .....													

Example: CP 2540-7R: DC-DC converter, input voltage range 33.6...75 V, each providing 15 V, equipped with R-control for output 1 and operating ambient temperature of -25...71 °C.

**Note:** All units feature the following auxiliary functions which are not shown in the type designation: input and output filter, inhibit (primary referenced), sense lines (single, double and triple output modules only) and LED indicators.

### Product Marking

Basic type designation, applicable safety approval and recognition marks, CE mark, warnings, pin allocation of input, output and auxiliary functions, Melcher patents and company logo. Label with specific type designation, input voltage range, nominal output voltage and output current, degree of protection, batch no., serial no. and data code including production site, modification status and date of production. Confirmation of success fully passed final test.

Identification of LED's.

**Mechanical Data**

Dimensions in mm. Tolerances  $\pm 0.3$  mm unless otherwise indicated.

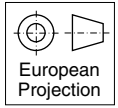

Preliminary

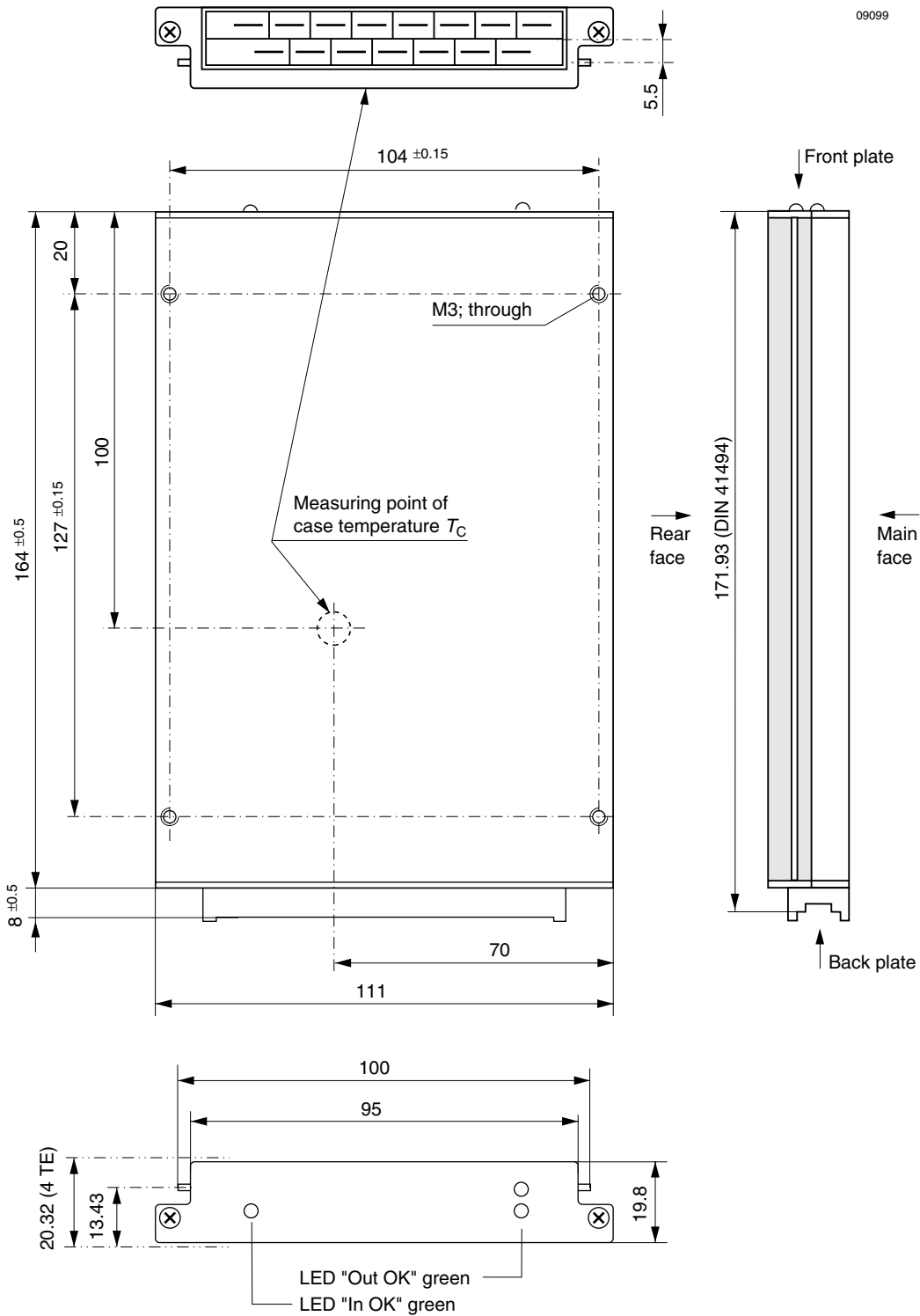

Fig. 8  
Case P01, weight 480 g  
Aluminium, fully enclosed,  
black finish and self cooling

**Note:** Long Cases, elongated by 60 mm for 220 mm rack depth is available on request.

Preliminary

## Safety and Installation Instructions

### Connector Pin Allocation

The connector pin allocation table defines the electrical potentials and the physical pin positions on the H15 connector. Pin no. 26, the protective earth pin present on all BP...GP DC-DC converters is leading, ensuring that it makes contact with the female connector first.

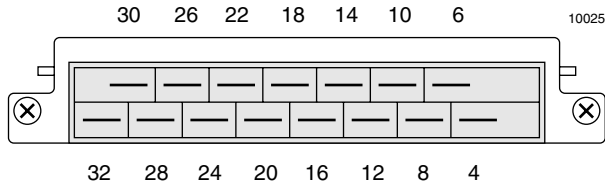

Fig. 9  
View of male H15 connector

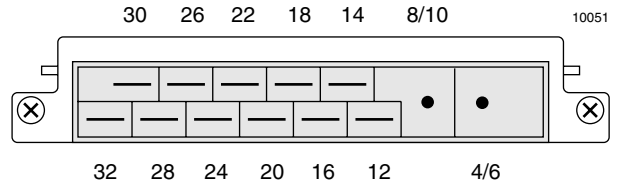

Fig. 10  
View of male H15 S2 connector for P 1000

Table 2: Pin allocation of the H15 S2 and H 15 connector

Pin	P 1000		P 2000		P 3000		P 4000	
4	Vo1+ <sup>1</sup>	Output 1	Vo1+	Output 1	Vo1+	Output 1	Vo1+	Output 1
6			Vo2+	Output 2	Vo2+	Output 2	Vo2+	Output 2
8	Vo1- <sup>1</sup>	Output 1	Vo1-	Output 1	Vo1-	Output 1	Vo1-	Output 1
10			Vo2-	Output 2	Vo2-	Output 2	Vo2-	Output 2
12	S+ <sup>2</sup>	Sense	S1+ <sup>2</sup>	Sense 1	S1+ <sup>2</sup>	Sense 1	Vo4+	Output 4
14	S- <sup>2</sup>	Sense	S1- <sup>2</sup>	Sense 1	S1- <sup>2</sup>	Sense 1	Vo4-	Output 4
16 <sup>3</sup>	R	Control of U <sub>o</sub>	R1	Control of U <sub>o1</sub>	R1	Control of U <sub>o1</sub>	R1/4	Control of U <sub>o1/4</sub>
					T1	Current sharing	T1	Current sharing
18 <sup>3</sup>	T	Current sharing	T1	Current sharing	Vo3+	Output 3	Vo3+	Output 3
			S2+	Sense 2				
20 <sup>3</sup>	n.c.	Not connected	S2-	Sense 2	Vo3-	Output 3	Vo3-	Output 3
	Pd in	Power down	Pd in	Power down				
22 <sup>3</sup>	Out OK+	Output good	Out OK+	Output good	Out OK+	Output good	Out OK+	Output good
	i+	Inhibit secondary	i+	Inhibit secondary				
	D	Save data	D	Save data				
24 <sup>3</sup>	Out OK-	Output good	Out OK-	Output good	Out OK-	Output good	Out OK-	Output good
	i-	Inhibit secondary	i-	Inhibit secondary				
	Rst	Reset	Rst	Reset				
26 <sup>2</sup>	⊕	Prot. ground	⊕	Prot. ground	⊕	Prot. ground	⊕	Prot. ground
28 <sup>3</sup>	i	Inhibit	i	Inhibit	i	Inhibit	i	Inhibit
	W	Synchronisat.	W	Synchronisat.				
30	Vi+	Input	Vi+	Input	Vi+	Input	Vi+	Input
32	Vi-	Input	Vi-	Input	Vi-	Input	Vi-	Input

<sup>1</sup> H15 S2 connector with two high current contacts.

<sup>2</sup> Leading pin (pre-connecting).

<sup>3</sup> One function/option per pin possible only.

## Installation Instruction

The P series DC-DC converters are components, intended exclusively for inclusion within other equipment by an industrial assembly operation or by professional installers. Installation must strictly follow the national safety regulations in compliance with the enclosure, mounting, creepage, clearance, casualty, markings and segregation requirements of the end-use application. See also: *Technical Information: Installation and Application*.

Connection to the system shall be made via the female connector H15 or H15 S2 (see: *Accessories*) according to Connector pin allocation. Other installation methods may not meet the safety requirements.

Check for hazardous voltages before altering any connections.

The DC-DC converters are provided with pin no. 26 (⊖), which is reliably connected to the case. For safety reasons it is essential to connect these pins to the protective earth of the supply system if required in: *Safety of operator accessible output circuit*.

The Vi input (pin no. 32) is internally fused. This fuse is designed to protect the unit in case of overcurrent and may not be able to satisfy all customer requirements. External fuses in the wiring to one or both input pins (no. 30 and/or no. 32) may therefore be necessary to ensure compliance with local requirements.

**Important:** Whenever the inhibit function is not in use, pin 28 (i) should be connected to pin 32 (Vi-) to enable the output(s).

Do not open the modules, or guarantee will be invalidated.

Make sure that there is sufficient air flow available for convection cooling. This should be verified by measuring the case temperature when the unit is installed and operated in the end-use application. The maximum specified case temperature  $T_C$  max must not be overridden.

Ensure that a unit failure (e.g. by an internal short-circuit) does not result in a hazardous condition. See also: *Safety of operator accessible output circuit*.

## Isolation

The electric strength test is performed as factory test in accordance with IEC/EN 60950 and UL 1950 and should not be repeated in the field. Melcher will not honour any guarantee claims resulting from electric strength field tests.

Table 3: Isolation

Characteristic		Input to case	Input to output(s)	Output to case	Output to output(s)	Auxiliary <sup>1</sup> to input	Auxiliary <sup>1</sup> to case	Auxiliary <sup>1</sup> to output	Unit
Electric strength test voltage	Required according to IEC/EN 60950	1.5	3.0 <sup>2</sup>	0.5	-	3.0 <sup>2</sup>	0.5	0.5	kV <sub>rms</sub>
		2.1	4.2 <sup>2</sup>	0.7	-	4.2 <sup>2</sup>	0.7	0.7	kV DC
	Actual factory test 1 s	2.1	4.2 <sup>2</sup>	1.5	0.5	4.2 <sup>2</sup>	1.5	0.5	
	AC test voltage equivalent to actual factory test	1.5	3.0 <sup>2</sup>	1.1	0.35	3.0 <sup>2</sup>	1.1	0.35	kV <sub>rms</sub>
Insulation resistance at 500 V DC		>300	>300	>300	>100	>300	>100	>100	MΩ

<sup>1</sup> Insulated auxiliary circuits, e.g. Out OK output circuit (option D), inhibit on output side (option i).

<sup>2</sup> In accordance with IEC/EN 60950 only subassemblies are tested in factory with this voltage.

## Cleaning Agents

In order to avoid possible damage, any penetration of cleaning fluids is to be prevented, since the power supplies are not hermetically sealed.

## Standards and approvals

All P series DC-DC converters correspond to class I equipment.

They are pending to be UL recognized according to UL 1950, UL recognized for Canada to CAN/CSA C22.2 No. 950-95 and LGA approved to IEC/EN 60950 standards and have been designed in accordance with these standards for:

- Building in
- Basic insulation between input and case, based on 250 V AC or 240 V DC
- Double or reinforced insulation between input and output, based on 250 V AC or 240 V DC
- Operational insulation between output(s) and case
- Operational insulation between the outputs
- Operational insulation between option D or i and output(s)
- Operational insulation between option D or i and case
- The use in a pollution degree 2 environment
- Connecting the input to a primary circuit with a maximum transient rating of 2500 V (overvoltage class III based on a 110 V primary circuit, overvoltage class II based on a 230 V primary circuit).

After approvals, the AC-DC converters are subject to manufacturing surveillance in accordance with the above mentioned UL, CSA, EN and with ISO 9001 standards.

## Protection Degree

Condition: Female connector fitted to the unit.

The protection degree of the DC-DC converters is IP 40.



**Safety of operator accessible output circuit**

If the output circuit of an DC-DC converter is operator accessible, it shall be an SELV circuit according to IEC/EN 60950 related safety standards

The following table shows some possible installation configurations, compliance with which causes the output circuit of the DC-DC converter to be an SELV circuit according to IEC/EN 60950 up to a configured output voltage (sum of

nominal voltages if in series or +/- configuration) of 35 V. However, it is the sole responsibility of the installer to assure the compliance with the relevant and applicable safety regulations. More information about this subject and about output circuits at hazardous voltages are given in: *Technical Information: Safety*.

Table 4: Safety concept leading to an SELV output circuit

Conditions	Front end			DC-DC converter	Result
Nominal supply voltage	Minimum required grade of insulation, to be provided by the AC-DC front end, including mains supplied battery charger	Maximum DC output voltage from the front end <sup>1</sup>	Minimum required safety status of the front end output circuit	Measures to achieve the specified safety status of the output circuit	Safety status of the DC-DC converter output circuit
Mains ≤250 V AC	Operational (i.e. there is no need for electrical isolation between the mains supply circuit and the DC-DC converter input circuit)	≤168 V	Primary circuit (The nominal voltage between any input pin and earth can be up to 250 V AC or 240 V DC.)	Double or reinforced insulation, based on 250 V AC and 240 V DC (provided by the DC-DC converter) and earthed case <sup>3</sup>	SELV circuit
	Basic		Earth related hazardous voltage secondary circuit <sup>2</sup> (The nominal voltage between any input pin and earth can be up to 250 V AC or 240 V DC.)	Double or reinforced insulation, based on the maximum nominal output voltage from the front end (both provided by the DC-DC converter) and earthed <sup>2</sup> case	
			Unearthed hazardous voltage secondary circuit	Supplementary insulation, based on 250 V AC and DC and double or reinforced insulation, based on the maximum nominal output voltage from the front end (both provided by the DC-DC converter) and earthed <sup>3</sup> case	
Supplementary		Unearthed hazardous voltage secondary circuit <sup>3</sup>	Basic insulation, based on 250 V AC and DC (provided by the DC-DC converter)		

<sup>1</sup> The front end output voltage should match the specified input voltage range of the DC-DC converter.

<sup>2</sup> The maximum rated input voltage of the EQ units according to IEC/EN 60950/UL 1950 is 150 V.

<sup>3</sup> Has to be insulated from earth by at least supplementary insulation (by the installer) according to the relevant safety standards, e.g. IEC/EN 60950, based on the maximum nominal output voltage from the front end. If the converter case is accessible, it has to be earthed or the front end output circuit has to be insulated from the converter case by at least basic insulation, based on the maximum nominal mains supply voltage.

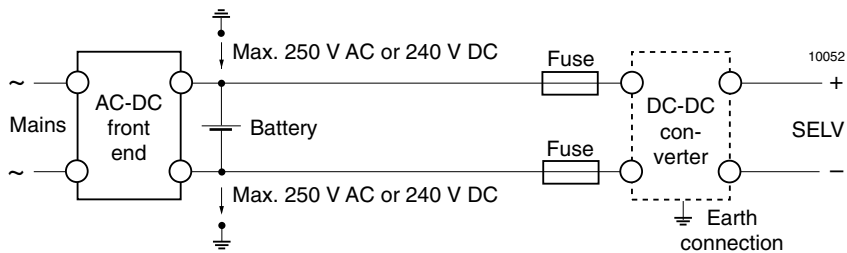

Fig. 11 Schematic safety concept

Use fuse, suppressor diode and earth connections as per table: *Safety concept leading to an SELV output circuit*. Use fuse(s) also if required by the application. See: *Installation Instructions*.