

Hybrid Surface Mount Aluminum Electrolytic Capacitors

NSPE Series

FEATURES

- CYLINDRICAL V-CHIP CONSTRUCTION FOR SURFACE MOUNTING
- SUPER LOW ESR & HIGH RIPPLE CURRENT
- CAPACITANCE VALUES UP TO 820μF
- 6.3x6.3mm ~ 10x10.8mm CASE SIZES
- DESIGNED FOR REFLOW SOLDERING

RoHS Compliant
includes all homogeneous materials

*See Part Number System for Details



CHARACTERISTICS

Rated Voltage Range	4 ~ 10Vdc			
Rated Capacitance Range	22 ~ 820μF			
Operating Temp. Range	-55 ~ +105°C			
Capacitance Tolerance	±20% (M)			
Max. Leakage Current After 2 Minutes @ 20°C	Less than 0.1CV or 50μA whichever is greater			
Working and Surge Voltage Ratings	W.V. (Vdc)	4	6.3	10
	S.V. (Vdc)	4.6	7.2	11.5
Tan δ @ 120Hz/20°C	All Case Sizes	0.24	0.22	0.20
Impedance Ratio	Z -55°C/Z +20°C	2.5		
	Z +105°C/Z +20°C	1.0		
Load Life Test @ 105°C 6.3mm Dia. and All 4Vdc parts = 1,000 Hours 8mm ~ 10mm Dia. parts = 2,000 Hours	Capacitance Change	Within ±20% of initial measured value		
	Tan δ	Less than 200% of specified max. value		
	Leakage Current	Less than specified max. value		

LOW ESR COMPONENT
HYBRID ELECTROLYTE
For Performance Data see www.LowESR.com

STANDARD PRODUCT AND CASE SIZE TABLE Dφ x L (mm)

Cap (μF)	Code	Working Voltage (Vdc)		
		4.0	6.3	10
22	220	-	-	6.3 x 6.3
33	330	-	-	6.3 x 6.3
47	470	-	-	6.3 x 6.3
100	101	-	6.3 x 6.3	8 x 10.8
150	151	-	-	8 x 10.8
220	221	-	8 x 10.8	8 x 10.8
330	331	-	8 x 10.8	8 x 10.8*
				10 x 10.8
390	391	-	8 x 10.8	10 x 10.8
470	471	8 x 10.8	10 x 10.8	10 x 10.8*
560	561	-	10 x 10.8	-
680	681	10 x 10.8	-	-
820	821	10 x 10.8	-	-

*Low temperature reflow soldering only

DIMENSIONS (mm)

Dφ ±0.5	L max.	A/B ±0.2	W	I ±0.2	P ±0.2
6.3	6.3	6.8	0.5 ~ 0.8	2.55	2.2
8.0	10.8	8.3	0.7 ~ 1.0	2.9	3.2
10	10.8	10.3	1.1 ~ 1.4	3.2	4.6

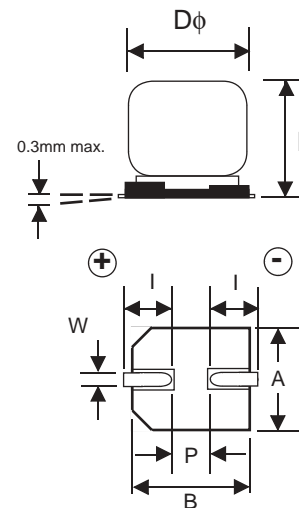

Part Marking

Series Code

Lot Code

Capacitance Value

Voltage

PART NUMBER SYSTEM

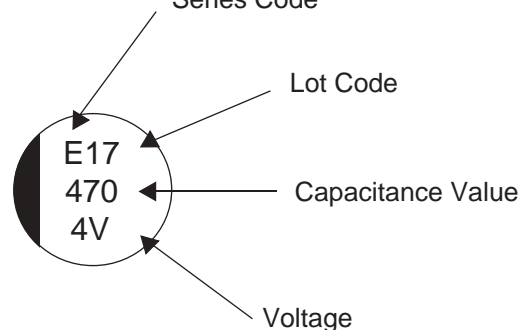
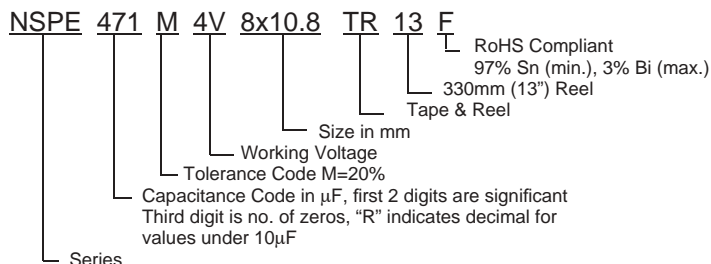

PRECAUTIONS

Please review the notes on correct use, safety and precautions found on pages T10 & T11 of NIC's Electrolytic Capacitor catalog.
Also found at www.niccomp.com/precautions
If in doubt or uncertainty, please review your specific application - process details with NIC's technical support personnel: tpmg@niccomp.com



STANDARD VALUES, CASE SIZES & SPECIFICATIONS

Part Number	Cap. (μF)	Working Voltage	Max. ESR (mΩ) AT 100KHz/20°C	Max. Ripple Current (mA rms) AT 100KHz/105°C
NSPE471M4V8X10.8TR13F	470	4	30	1,550
NSPE681M4V10X10.8TR13F	680		25	2,090
NSPE821M4V10X10.8TR13F	820		23	2,180
NSPE101M6.3V6.3X6.3TR13F	100	6.3	50	1,120
NSPE221M6.3V8X10.8TR13F	220		30	1,550
NSPE331M6.3V8X10.8TR13F	330		30	1,550
NSPE391M6.3V8X10.8TR13F	390		30	1,550
NSPE471M6.3V10X10.8TR13F	470		25	2,090
NSPE561M6.3V10X10.8TR13F	560		25	2,090
NSPE220M10V6.3X6.3TR13F	22	10	60	1,020
NSPE330M10V6.3X6.3TR13F	33		60	1,020
NSPE470M10V6.3X6.3TR13F	47		60	1,020
NSPE101M10V8X10.8TR13F	100		30	1,550
NSPE151M10V8X10.8TR13F	150		30	1,550
NSPE221M10V8X10.8TR13F	220		30	1,550
NSPE331M10V8X10.8TR13F*	330		30*	1,550*
NSPE331M10V10X10.8TR13F			25	2090
NSPE391M10V10X10.8TR13F	390		25	2,090
NSPE471M10V10X10.8TR13F*	470		25*	2,090*

*Low temperature reflow soldering only

PEAK TEMPERATURE AND DURATION

Diameter/Voltage	Preheat (120 sec. max.)	Peak Temperature	Time above 200°C	Time above 230°C
6.3mm/4V ~ 10V	150°C ~ 180°C	250°C/5 sec.	60 sec. max.	40 sec. max.
8.0mm/4V ~ 10V	150°C ~ 180°C	240°C/5 sec.	60 sec. max.	30 sec. max.
10mm/4V ~ 10V	150°C ~ 180°C	235°C/5 sec.	50 sec. max.	5 sec. max.
NSPE471M6.3V10x10.8TRxxF	150°C ~ 180°C	240°C/5 sec.	60 sec. max.	30 sec. max.
NSPE331M10V8x10.8TRxxF	<150°C	230°C/5 sec.	30 sec. max.	-
NSPE471M10V10x10.8TRxxF				

LAND PATTERN DIM. (mm)

Case Dia.	A	B	P
6.3	3.5	1.6	1.9
8	4.2	2.2	3.1
10	4.4	2.2	4.5

RECOMMENDED REFLOW SOLDERING PROFILE

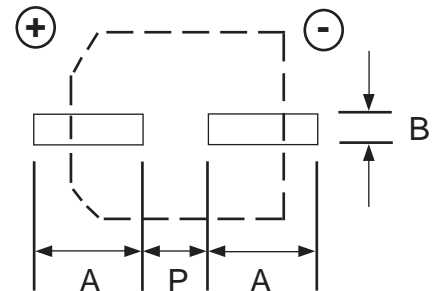
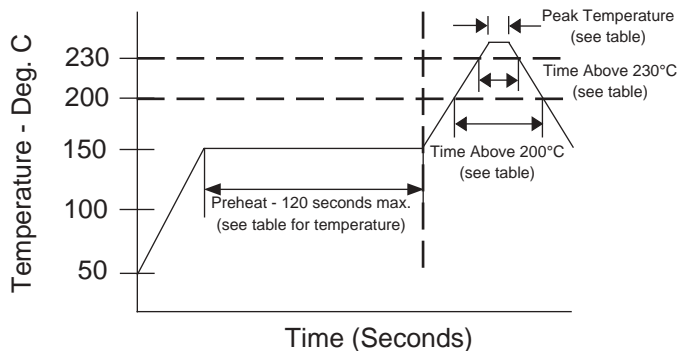

Review & Compare Reflow Soldering Heat Limits
V-chip SMT Aluminum Electrolytic Capacitors
www.niccomp.com/RSL