

IS61SP25616

256K x 16 SYNCHRONOUS PIPELINED STATIC RAM

ADVANCE INFORMATION
MARCH 1999

FEATURES

- Internal self-timed write cycle
- Individual Byte Write Control and Global Write
- Clock controlled, registered address, data and control
- Pentium™ or linear burst sequence control using MODE input
- Three chip enables for simple depth expansion and address pipelining
- Common data inputs and data outputs
- JEDEC 100-Pin TQFP and 119-pin PBGA package
- Single +3.3V, +10%, -5% power supply
- 3.3V I/O supply
- Power-down snooze mode

DESCRIPTION

The *ISSI* IS61SP25616 is a high-speed, low-power synchronous static RAM designed to provide a burstable, high-performance, secondary cache for the Pentium™, 680X0™, and PowerPC™ microprocessors. It is organized as 262,144 words by 16 bits, fabricated with *ISSI*'s advanced CMOS technology. The device integrates a 2-bit burst counter, high-speed SRAM core, and high-drive capability outputs into a single monolithic circuit. All synchronous inputs pass through registers controlled by a positive-edge-triggered single clock input.

Write cycles are internally self-timed and are initiated by the rising edge of the clock input. Write cycles can be from one to four bytes wide as controlled by the write control inputs.

Separate byte enables allow individual bytes to be written. $\overline{BW1}$ controls DQa, $\overline{BW2}$ controls DQb, conditioned by \overline{BWE} being LOW. A LOW on \overline{GW} input would cause all bytes to be written.

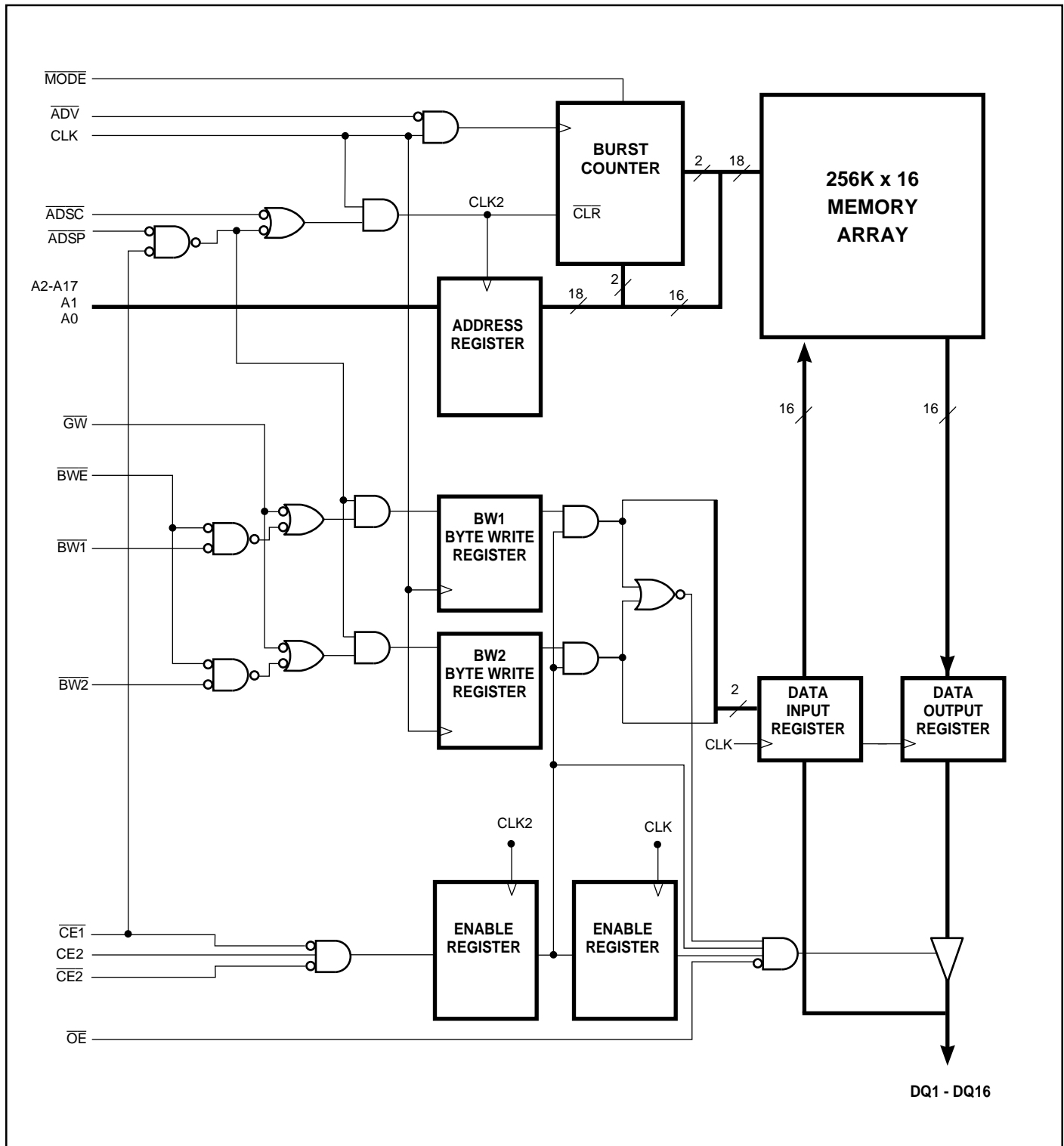
Bursts can be initiated with either \overline{ADSP} (Address Status Processor) or \overline{ADSC} (Address Status Cache Controller) input pins. Subsequent burst addresses can be generated internally by the IS61SP25616 and controlled by the ADV (burst address advance) input pin.

The mode pin is used to select the burst sequence order, Linear burst is achieved when this pin is tied LOW. Interleave burst is achieved when this pin is tied HIGH or left floating.

FAST ACCESS TIME

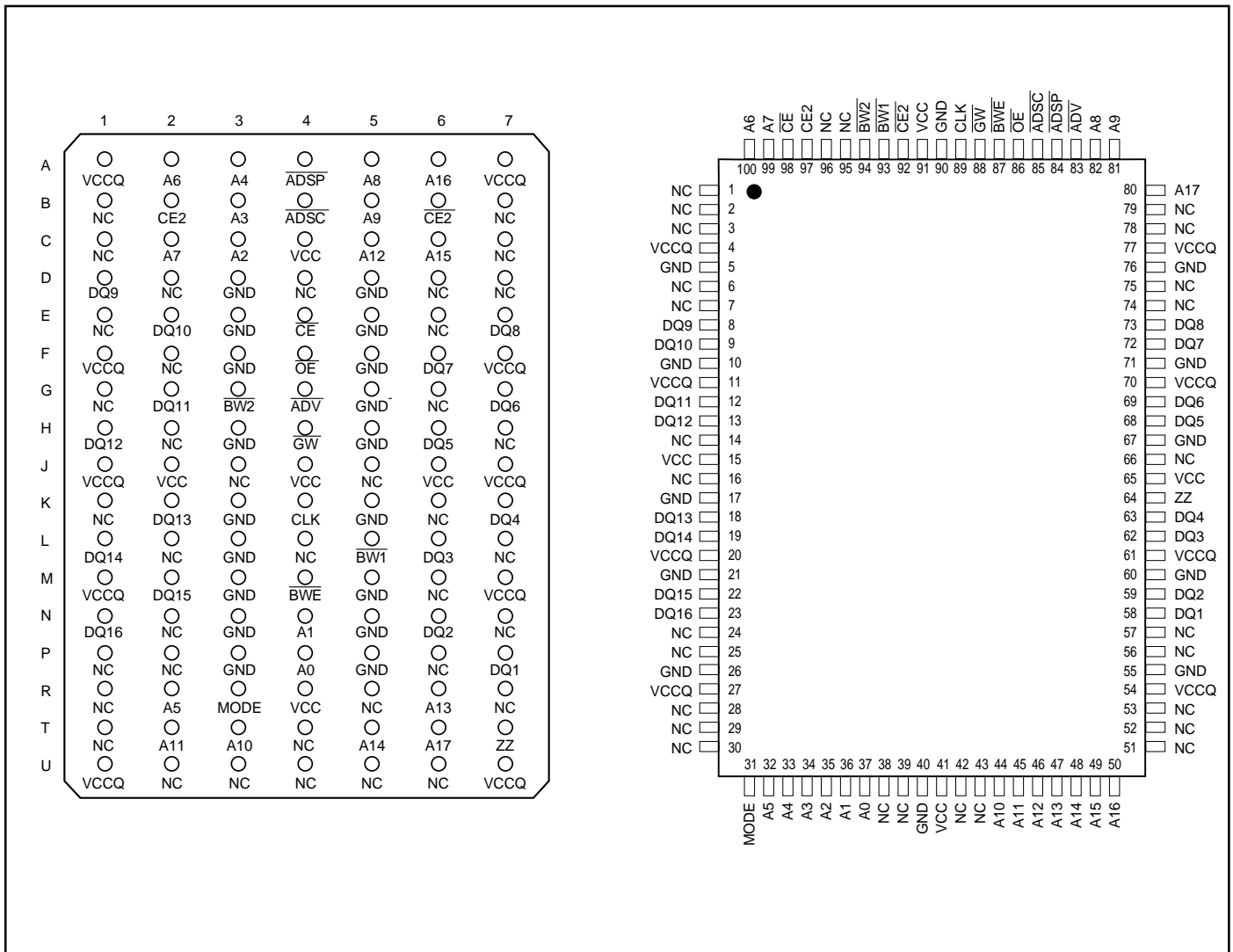
Symbol	Parameter	-166	-150	-133	-117	-5	Units
tkQ	Clock Access Time	5	5	5	5	5	ns
tkC	Cycle Time	6	6.7	7.5	8.5	10	ns
	Frequency	166	150	133	117	100	MHz

BLOCK DIAGRAM



PIN CONFIGURATION

119-pin PBGA (Top View) and 100-Pin TQFP



PIN DESCRIPTIONS

A0, A1	Synchronous Address Inputs. These pins must tied to the two LSBs of the address bus.
A2-A17	Synchronous Address Inputs
CLK	Synchronous Clock
ADSP	Synchronous Processor Address Status
ADSC	Synchronous Controller Address Status
ADV	Synchronous Burst Address Advance
BW1-BW2	Synchronous Byte Write Enable
BWE	Synchronous Byte Write Enable

\overline{GW}	Synchronous Global Write Enable
\overline{CE} , $\overline{CE2}$, $\overline{CE2}$	Synchronous Chip Enable
\overline{OE}	Output Enable
DQ1-DQ16	Synchronous Data Input/Output
MODE	Burst Sequence Mode Selection
Vcc	+3.3V Power Supply
GND	Ground
Vccq	Isolated Output Buffer Supply: +3.3V
ZZ	Snooze Enable
GNDq	Isolated Output Buffer Ground

TRUTH TABLE

Operation	Address Used	\overline{CE}	CE2	$\overline{CE2}$	\overline{ADSP}	\overline{ADSC}	\overline{ADV}	Write ^(2,4)	\overline{OE}	DQ
Deselected, Power-down	None	H	X	X	X	L	X	X	X	High-Z
Deselected, Power-down	None	L	X	H	L	X	X	X	X	High-Z
Deselected, Power-down	None	L	L	X	L	X	X	X	X	High-Z
Deselected, Power-down	None	X	X	H	H	L	X	X	X	High-Z
Deselected, Power-down	None	X	0	X	H	L	X	X	X	High-Z
Read Cycle, Begin Burst	External	L	H	L	L	X	X	X ⁵	X	High-Z
Read Cycle, Begin Burst	External	L	H	L	H	0	X	Read ⁵	X	High-Z
Write Cycle, Begin Burst	External	L	H	L	H	L	X	Write	X	High-Z
Read Cycle, Continue Burst	Next	X	X	X	H	H	L	Read	L	DQ
Read Cycle, Continue Burst	Next	X	X	X	H	H	L	Read	H	High-Z
Read Cycle, Continue Burst	Next	H	X	X	X	H	L	Read	L	DQ
Read Cycle, Continue Burst	Next	H	X	X	X	H	L	Read	H	High-Z
Write Cycle, Continue Burst	Next	X	X	X	H	H	L	Write	X	High-Z
Write Cycle, Continue Burst	Next	H	X	X	X	H	L	Write	X	High-Z
Read Cycle, Suspend Burst	Current	X	X	X	H	H	H	Read	L	DQ
Read Cycle, Suspend Burst	Current	X	X	X	H	H	H	Read	H	High-Z
Read Cycle, Suspend Burst	Current	H	X	X	X	H	H	Read	L	DQ
Read Cycle, Suspend Burst	Current	H	X	X	X	H	H	Read	H	High-Z
Write Cycle, Suspend Burst	Current	X	X	X	H	H	H	Write	X	High-Z
Write Cycle, Suspend Burst	Current	H	X	X	X	H	H	Write	X	High-Z

NOTES:

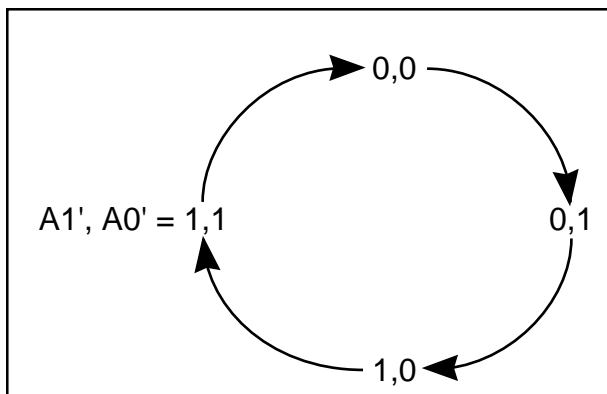
1. X = Don't Care. 1 = logic low.
2. Write is defined as either 1.) any \overline{BWx} and \overline{BWE} low or 2.) \overline{GW} is low.
3. \overline{OE} is an asynchronous signal and is not sampled by the clock CLK. \overline{OE} drives the bus immediately (toELZ) following \overline{OE} going low.
4. On write cycles that follow read cycles, \overline{OE} must be negated prior to the start of the write cycle to ensure proper write data setup times. \overline{OE} must also remain negated at the completion of the write cycle to ensure proper write data hold times.
5. This read assumes the RAM was previously deselected.

PARTIAL TRUTH TABLE

Function	\overline{GW}	\overline{BWE}	$\overline{BW1}$	$\overline{BW2}$
Read	H	H	X	X
Read	H	L	H	H
Write Byte a	H	L	L	H
Write Byte b	H	L	H	L
Write All Bytes	H	L	L	L
Write All Bytes	L	X	X	X

INTERLEAVED BURST ADDRESS TABLE (MODE = Vccq or No Connect)

External Address A1 A0	1st Burst Address A1 A0	2nd Burst Address A1 A0	3rd Burst Address A1 A0
00	01	10	11
01	00	11	10
10	11	00	01
11	10	01	00

LINEAR BURST ADDRESS TABLE (MODE = GNDq)**ABSOLUTE MAXIMUM RATINGS⁽¹⁾**

Symbol	Parameter	Value	Unit
T _{BIAS}	Temperature Under Bias	-40 to +85	°C
T _{STG}	Storage Temperature	-55 to +150	°C
P _D	Power Dissipation	1.6	W
I _{OUT}	Output Current (per I/O)	100	mA
V _{IN} , V _{OUT}	Voltage Relative to GND for I/O Pins	-0.5 to V _{CCQ} + 0.3	V
V _{IN}	Voltage Relative to GND for for Address and Control Inputs	-0.5 to V _{CC} + 0.5	V
V _{CC}	Voltage on V _{CC} Supply Relative to GND	-0.5 to 4.6	V

Notes:

1. Stress greater than those listed under ABSOLUTE MAXIMUM RATINGS may cause permanent damage to the device. This is a stress rating only and functional operation of the device at these or any other conditions above those indicated in the operational sections of this specification is not implied. Exposure to absolute maximum rating conditions for extended periods may affect reliability.
2. This device contains circuitry to protect the inputs against damage due to high static voltages or electric fields; however, precautions may be taken to avoid application of any voltage higher than maximum rated voltages to this high-impedance circuit.
3. This device contains circuitry that will ensure the output devices are in High-Z at power up.

OPERATING RANGE

Range	Ambient Temperature	V _{CC} / V _{CCQ}
Commercial	0°C to +70°C	3.3V +10%, -5%
Industrial	-40°C to +85°C	3.3V +10%, -5%

DC ELECTRICAL CHARACTERISTICS⁽¹⁾ (Over Operating Range)

Symbol	Parameter	Test Conditions	Min.	Max.	Unit	
V _{OH}	Output HIGH Voltage	I _{OH} = -4.0 mA, V _{CCQ} = 3.3V	2.4	—	V	
V _{OL}	Output LOW Voltage	I _{OL} = 8.0 mA, V _{CCQ} = 3.3V	—	0.4	V	
V _{IH}	Input HIGH Voltage		2.0	V _{CC} + 0.3	V	
V _{IL}	Input LOW Voltage		-0.3	0.8	V	
I _{LI}	Input Leakage Current	GND ≤ V _{IN} ≤ V _{CCQ} ⁽²⁾	Com. Ind.	-2 5	2 5	μA
I _{LO}	Output Leakage Current	GND ≤ V _{OUT} ≤ V _{CCQ} , $\overline{OE} = V_{IH}$	Com. Ind.	-2 -5	2 5	μA

POWER SUPPLY CHARACTERISTICS (Over Operating Range)

Symbol	Parameter	Test Conditions		-166 Max.	-150 Max.	-133 Max.	-117 Max.	-5 Max.	Unit
I _{CC}	AC Operating Supply Current	Device Selected, All Inputs = V _{IL} or V _{IH} $\overline{OE} = V_{IH}$, V _{CC} = Max. Cycle Time ≥ t _{kc} min.	Com. Ind.	200 —	190 200	180 190	170 180	160 170	mA
I _{SB}	Standby Current	Device Deselected, V _{CC} = Max., All Inputs = V _{IH} or V _{IL} CLK Cycle Time ≥ t _{kc} min.	Com. Ind.	70 —	65 70	60 65	55 60	50 55	mA
I _{ZZ}	Power-down Mode Current	ZZ = V _{CCQ} Clock Running All Inputs ≤ GND + 0.2V or ≥ V _{CC} - 0.2V	Com. Ind.	5 —	5 15	5 15	5 15	5 15	mA

Notes:

- The MODE pin has an internal pullup. This pin may be a No Connect, tied to GND, or tied to V_{CCQ}.
- The MODE pin should be tied to V_{CC} or GND. It exhibits ±10 μA maximum leakage current when tied to ≤ GND + 0.2V or ≥ V_{CC} - 0.2V.

CAPACITANCE^(1,2)

Symbol	Parameter	Conditions	Max.	Unit
C _{IN}	Input Capacitance	V _{IN} = 0V	5	pF
C _{OUT}	Input/Output Capacitance	V _{OUT} = 0V	8	pF

Notes:

1. Tested initially and after any design or process changes that may affect these parameters.
2. Test conditions: T_A = 25°C, f = 1 MHz, V_{CC} = 3.3V.

AC TEST CONDITIONS

Parameter	Unit
Input Pulse Level	0V to 3V
Input Rise and Fall Times	1.5 ns
Input and Output Timing and Reference Level	1.5V
Output Load	See Figures 1 and 2

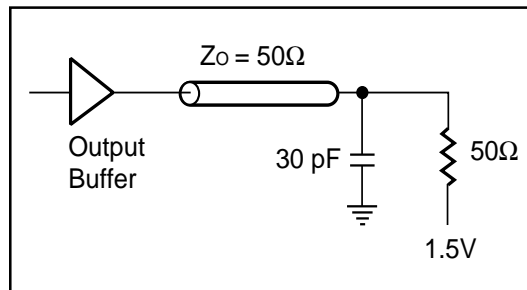
AC TEST LOADS

Figure 1

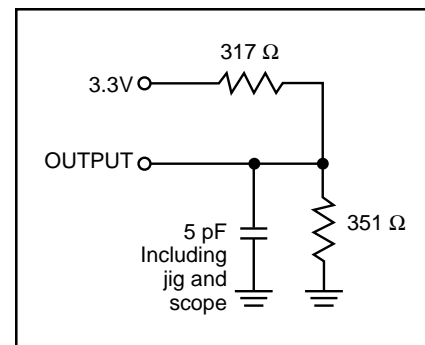


Figure 2

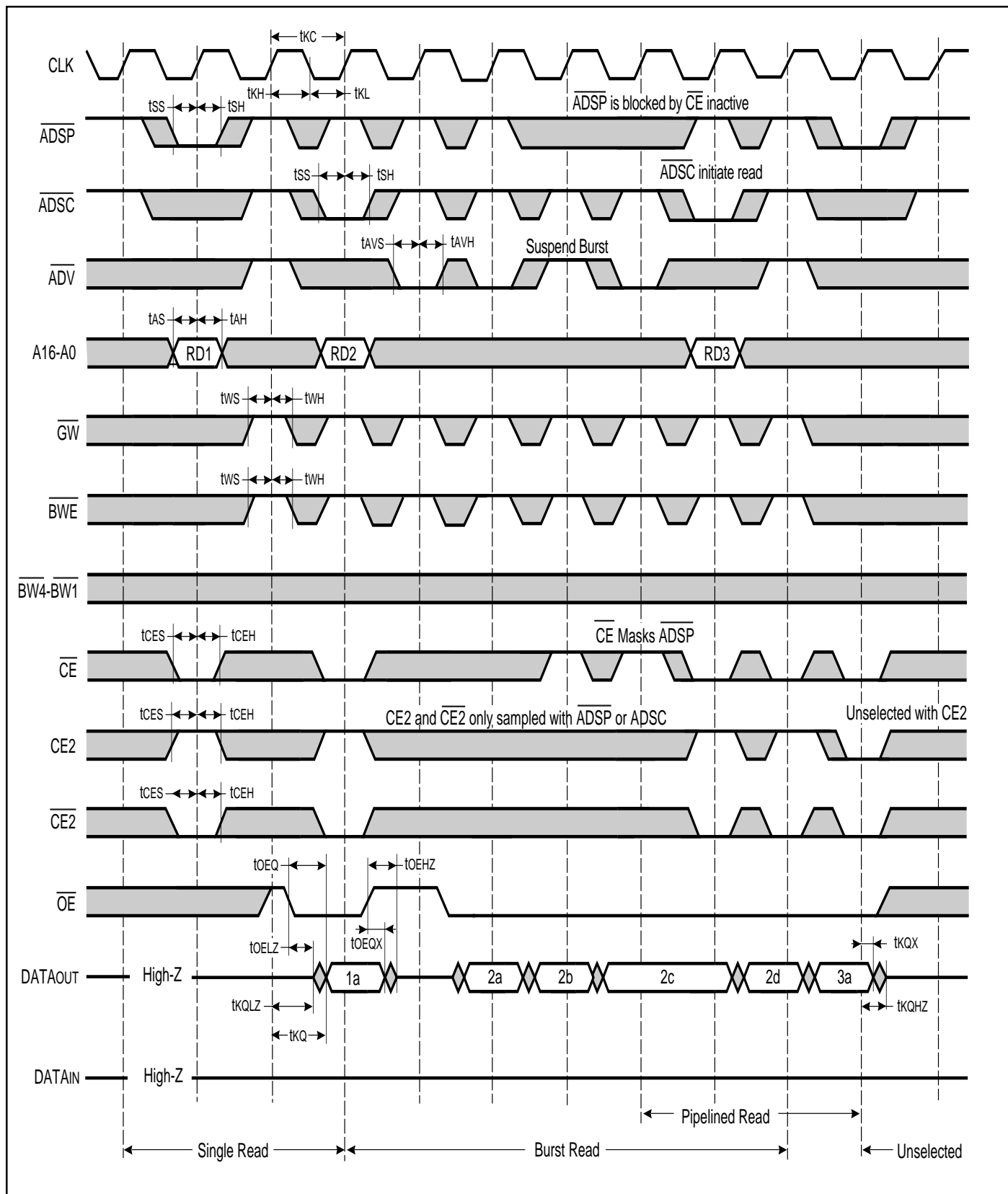
READ/WRITE CYCLE SWITCHING CHARACTERISTICS (Over Operating Range)

Symbol	Parameter	-166		-150		-133		-117		-5		Unit
		Min.	Max.	Min.	Max.	Min.	Max.	Min.	Max.	Min.	Max.	
f _{MAX}	Clock Frequency	—	166	—	150	—	133	—	117	—	100	MHz
t _{KC}	Cycle Time	6	—	6.7	—	7.5	—	8.5	—	10	—	ns
t _{KH}	Clock High Time	2.4	—	2.6	—	2.8	—	3.4	—	4	—	ns
t _{KL}	Clock Low Time	2.4	—	2.6	—	2.8	—	3.4	—	4	—	ns
t _{KQ}	Clock Access Time	—	5	—	5	—	5	—	5	—	5	ns
t _{KQX} ⁽¹⁾	Clock High to Output Invalid	1.5	—	1.7	—	1.9	—	1.5	—	2.5	—	ns
t _{KQLZ} ^(1,2)	Clock High to Output Low-Z	0	—	0	—	0	—	0	—	0	—	ns
t _{KQHZ} ^(1,2)	Clock High to Output High-Z	1.3	6	1.5	6.7	1.5	7.5	1.5	8.5	1.5	10	ns
t _{OEQ}	Output Enable to Output Valid	—	3.5	—	3.5	—	3.8	—	4	—	5	ns
t _{OEQX} ⁽¹⁾	Output Disable to Output Invalid	0	—	0	—	0	—	0	—	0	—	ns
t _{OE LZ} ^(1,2)	Output Enable to Output Low-Z	0	—	0	—	0	—	0	—	0	—	ns
t _{OE HZ} ^(1,2)	Output Disable to Output High-Z	2	3.5	2	3.5	2	3.8	2	4.2	2	5	ns
t _{AS}	Address Setup Time	1.5	—	1.5	—	1.5	—	1.5	—	1.5	—	ns
t _{SS}	Address Status Setup Time	1.5	—	1.5	—	1.5	—	1.5	—	1.5	—	ns
t _{WS}	Write Setup Time	1.5	—	1.5	—	1.5	—	1.5	—	1.5	—	ns
t _{CES}	Chip Enable Setup Time	1.5	—	1.5	—	1.5	—	1.5	—	1.5	—	ns
t _{AVS}	Address Advance Setup Time	1.5	—	1.5	—	1.5	—	1.5	—	1.5	—	ns
t _{AH}	Address Hold Time	0.5	—	0.5	—	0.5	—	0.5	—	0.5	—	ns
t _{SH}	Address Status Hold Time	0.5	—	0.5	—	0.5	—	0.5	—	0.5	—	ns
t _{WH}	Write Hold Time	0.5	—	0.5	—	0.5	—	0.5	—	0.5	—	ns
t _{CEH}	Chip Enable Hold Time	0.5	—	0.5	—	0.5	—	0.5	—	0.5	—	ns
t _{AVH}	Address Advance Hold Time	0.5	—	0.5	—	0.5	—	0.5	—	0.5	—	ns

Notes:

1. Guaranteed but not 100% tested. This parameter is periodically sampled.
2. Tested with load in Figure 2.

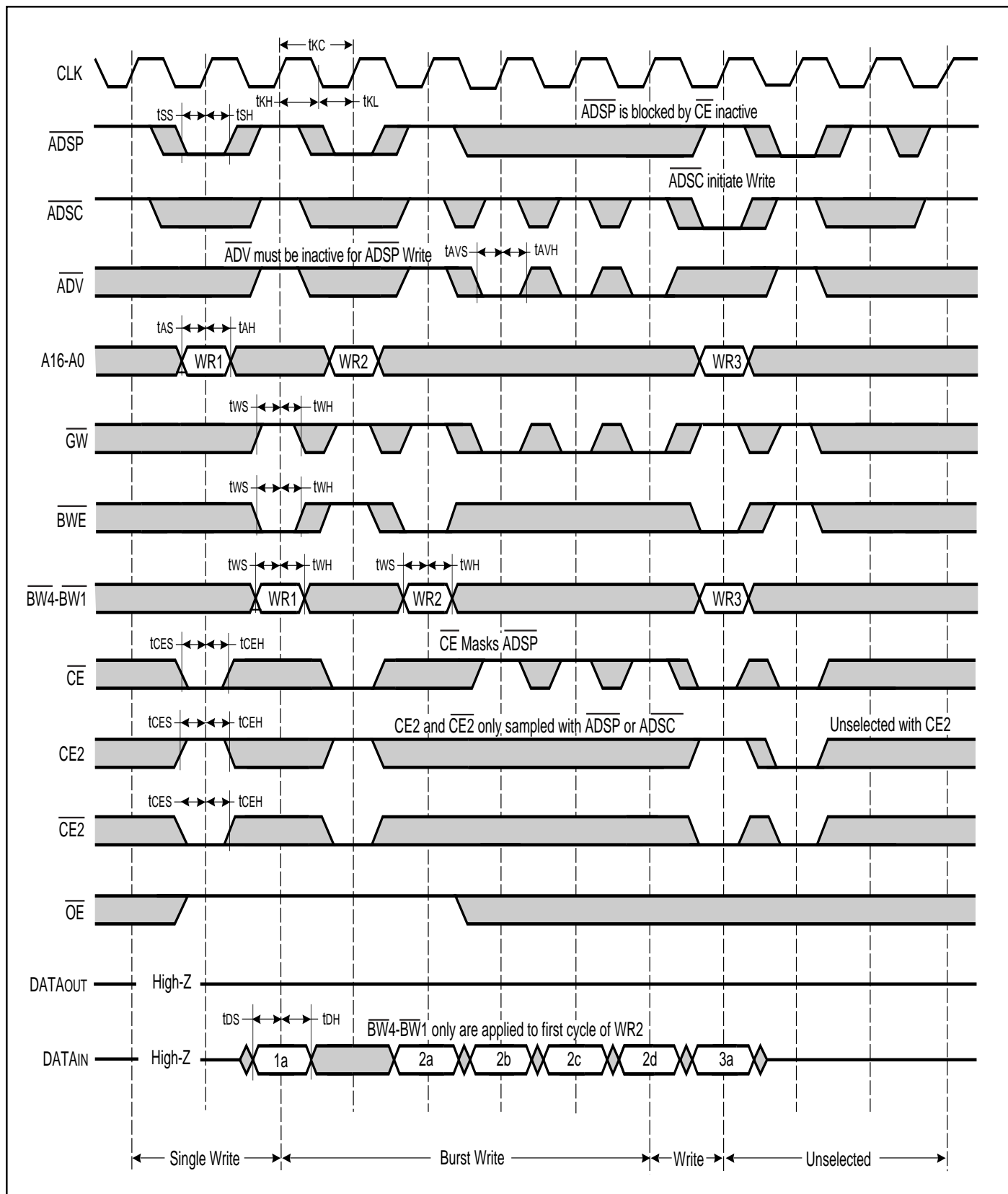
READ/WRITE CYCLE TIMING



WRITE CYCLE SWITCHING CHARACTERISTICS (Over Operating Range)

Symbol	Parameter	-166		-150		-133		-117		-5		Unit
		Min.	Max.	Min.	Max.	Min.	Max.	Min.	Max.	Min.	Max.	
t _{CC}	Cycle Time	6	—	6.7	—	7.5	—	8.5	—	10	—	ns
t _{KH}	Clock High Time	2.4	—	2.6	—	2.8	—	3.4	—	4	—	ns
t _{KL}	Clock Low Time	2.4	—	2.6	—	2.8	—	3.4	—	4	—	ns
t _{DS}	Data In Setup Time	2	—	2	—	2	—	2	—	2	—	ns
t _{AS}	Address Setup Time	1.5	—	1.5	—	1.5	—	1.5	—	1.5	—	ns
t _{SS}	Address Status Setup Time	1.5	—	1.5	—	1.5	—	1.5	—	1.5	—	ns
t _{WS}	Write Setup Time	1.5	—	1.5	—	1.5	—	1.5	—	1.5	—	ns
t _{CES}	Chip Enable Setup Time	1.5	—	1.5	—	1.5	—	1.5	—	1.5	—	ns
t _{AVS}	Address Advance Setup Time	1.5	—	1.5	—	1.5	—	1.5	—	1.5	—	ns
t _{AH}	Address Hold Time	0.5	—	0.5	—	0.5	—	0.5	—	0.5	—	ns
t _{SH}	Address Status Hold Time	0.5	—	0.5	—	0.5	—	0.5	—	0.5	—	ns
t _{DH}	Data In Hold Time	0.5	—	0.5	—	0.5	—	0.5	—	0.5	—	ns
t _{WH}	Write Hold Time	0.5	—	0.5	—	0.5	—	0.5	—	0.5	—	ns
t _{CEH}	Chip Enable Hold Time	0.5	—	0.5	—	0.5	—	0.5	—	0.5	—	ns
t _{AVH}	Address Advance Hold Time	0.5	—	0.5	—	0.5	—	0.5	—	0.5	—	ns

WRITE CYCLE TIMING



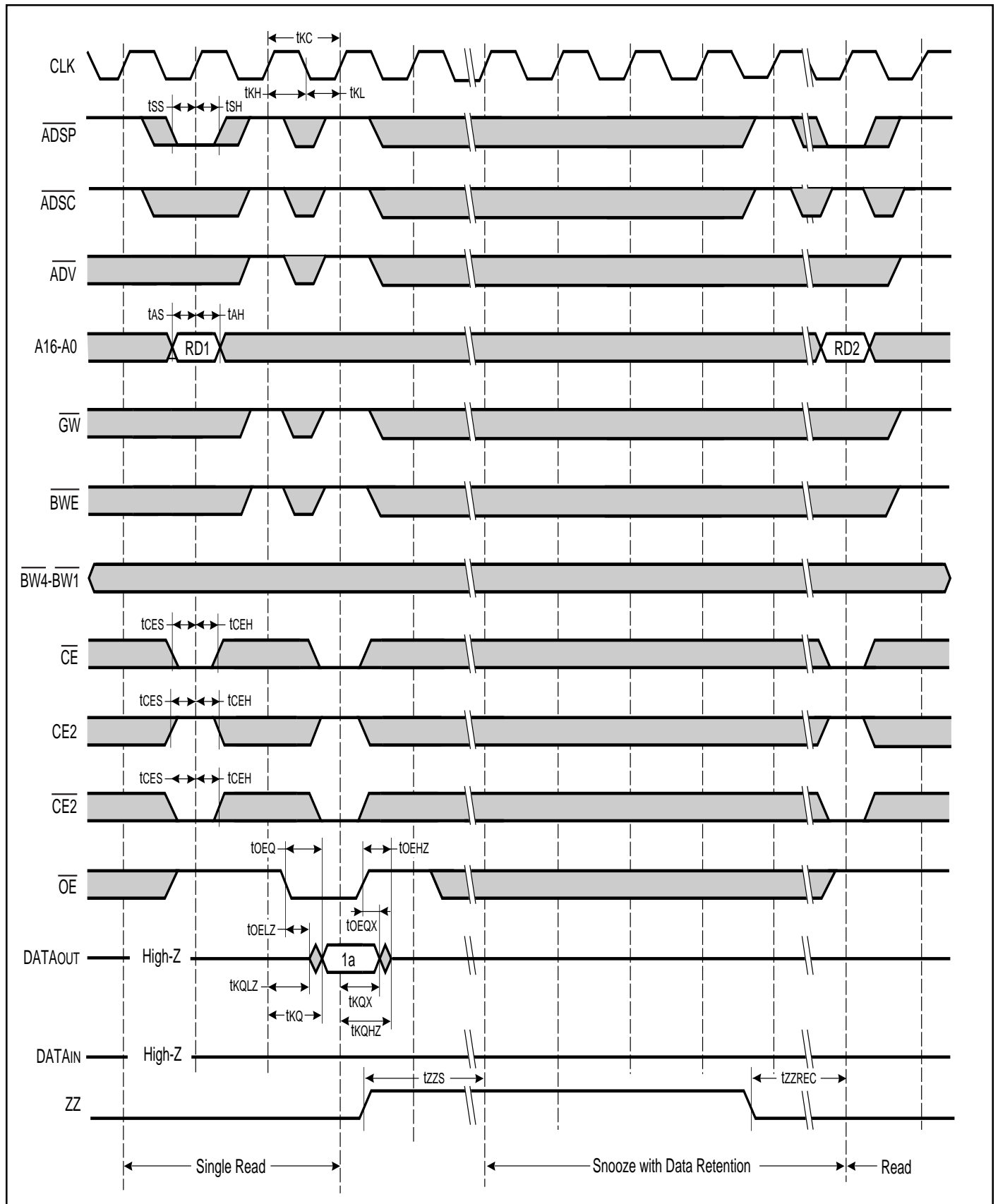
SNOOZE AND RECOVERY CYCLE SWITCHING CHARACTERISTICS (Over Operating Range)

Symbol	Parameter	-166		-150		-133		-117		-5		Unit
		Min.	Max.	Min.	Max.	Min.	Max.	Min.	Max.	Min.	Max.	
t _{CC}	Cycle Time	6	—	6.7	—	7.5	—	8.5	—	10	—	ns
t _{CH}	Clock High Time	2.4	—	2.6	—	2.8	—	3.4	—	4	—	ns
t _{CL}	Clock Low Time	2.4	—	2.6	—	2.8	—	3.4	—	4	—	ns
t _{CQ}	Clock Access Time	—	5	—	5	—	5	—	5	—	5	ns
t _{QX} ⁽¹⁾	Clock High to Output Invalid	1.5	—	1.7	—	1.9	—	1.5	—	2.5	—	ns
t _{QZ} ^(1,2)	Clock High to Output Low-Z	0	—	0	—	0	—	0	—	0	—	ns
t _{QHZ} ^(1,2)	Clock High to Output High-Z	1.3	3.6	1.5	6.7	1.5	7.5	1.5	8.5	1.5	10	ns
t _{OEQ}	Output Enable to Output Valid	—	3.5	—	3.5	—	3.9	—	4	—	5	ns
t _{OEQX} ⁽¹⁾	Output Disable to Output Invalid	0	—	0	—	0	—	0	—	0	—	ns
t _{OEZ} ^(1,2)	Output Enable to Output Low-Z	0	—	0	—	0	—	0	—	0	—	ns
t _{OEHZ} ^(1,2)	Output Disable to Output High-Z	2	3.5	2	3.5	2	3.8	2	4.2	2	5	ns
t _{AS}	Address Setup Time	1.5	—	1.5	—	1.5	—	1.5	—	1.5	—	ns
t _{SS}	Address Status Setup Time	1.5	—	1.5	—	1.5	—	1.5	—	1.5	—	ns
t _{CEs}	Chip Enable Setup Time	1.5	—	1.5	—	1.5	—	1.5	—	1.5	—	ns
t _{AH}	Address Hold Time	0.5	—	0.5	—	0.5	—	0.5	—	0.5	—	ns
t _{SH}	Address Status Hold Time	0.5	—	0.5	—	0.5	—	0.5	—	0.5	—	ns
t _{CEH}	Chip Enable Hold Time	0.5	—	0.5	—	0.5	—	0.5	—	0.5	—	ns
t _{ZZS}	ZZ Standby	2	—	2	—	2	—	2	—	2	—	cyc
t _{ZZREC}	ZZ Recovery	2	—	2	—	2	—	2	—	2	—	cyc

Notes:

1. Guaranteed but not 100% tested. This parameter is periodically sampled.
2. Tested with load in Figure 2.

SNOOZE AND RECOVERY CYCLE TIMING



ORDERING INFORMATION**Commercial Range: 0°C to +70°C**

Frequency	Order Part Number	Package
166	IS61SP25616-166TQ	TQFP
	IS61SP25616-166B	PBGA
150	IS61SP25616-150TQ	TQFP
	IS61SP25616-150B	PBGA
133	IS61SP25616-133TQ	TQFP
	IS61SP25616-133B	PBGA
117	IS61SP25616-117TQ	TQFP
	IS61SP25616-117B	PBGA
100	IS61SP25616-5TQ	TQFP
	IS61SP25616-5B	PBGA

Industrial Range: -40°C to +85°C

Frequency	Order Part Number	Package
150	IS61SP25616-150TQI	TQFP
133	IS61SP25616-133TQI	TQFP
117	IS61SP25616-117TQI	TQFP
100	IS61SP25616-5TQI	TQFP

ISSI®

Integrated Silicon Solution, Inc.

2231 Lawson Lane
 Santa Clara, CA 95054
 Tel: 1-800-379-4774
 Fax: (408) 588-0806
 E-mail: sales@issi.com
www.issi.com