

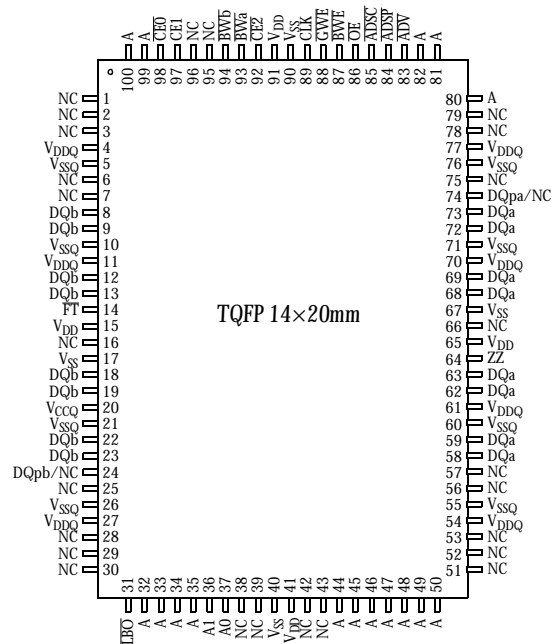

3.3V 256K × 16/18 pipeline burst synchronous SRAM

- Organization: 262,144 words × 16 or 18 bits
- Fast clock speeds to 166 MHz in LVTTTL/LVCMOS
- Fast clock to data access: 3.5/3.8/4/5 ns
- Fast OE access time: 3.5/3.5/3.8/5.0 ns
- Fully synchronous register-to-register operation
- “Flow-through” mode
- Single-cycle deselect
- Double-cycle deselect also available (AS7C3256PFD16A/AS7C3256PFD18A)
- Pentium® compatible architecture and timing
- Synchronous and asynchronous output enable control
- Economical 100-pin TQFP package
- Byte write enables
- Clock enable for operation hold
- Multiple chip enables for easy expansion
- 3.3V core power supply
- 2.5V or 3.3V I/O operation with separate V_{DDQ}
- Automatic power down: 30 mW typical standby power
- NTD™ pipeline architecture available (AS7C3256NTD16A/AS7C3256NTD18A)

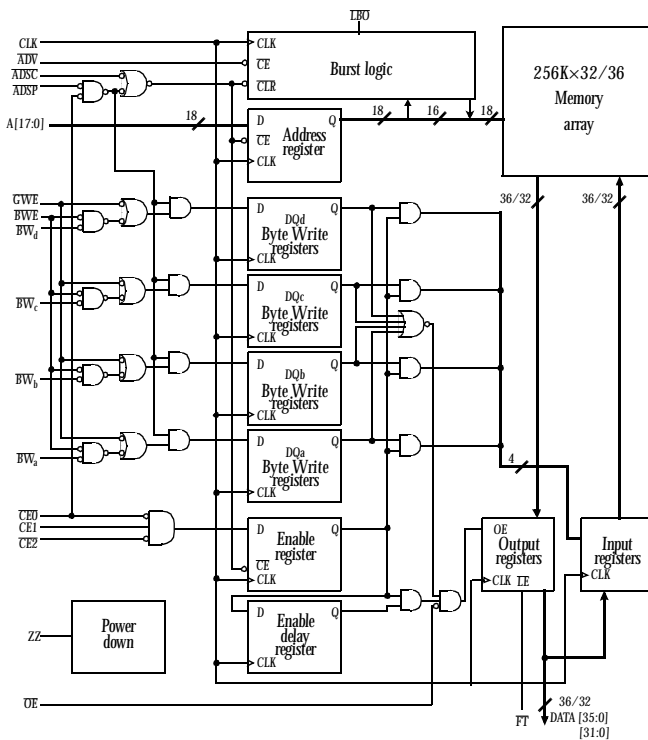

Note: pins 24, 74 are NC for ×16.

	AS7C3256PFS16A-3.5	AS7C3256PFS16A-3.8	AS7C3256PFS16A-4	AS7C3256PFS16A-5	Units
Minimum cycle time	6	6.7	7.5	10	ns
Maximum pipelined clock frequency	166.7	150	133.3	100	MHz
Maximum pipelined clock access time	3.5	3.8	4	5	ns
Maximum operating current	450	400	350	300	mA
Maximum standby current	60	60	60	60	mA
Maximum CMOS standby current (DC)	5	5	5	5	mA

NTD™ is a trademark of Alliance Semiconductor Corporation
Pentium® is a registered trademark of Intel Corporation.



The AS7C3256PFS16A and AS7C3256PFS18A are high performance CMOS 4 Mbit synchronous Static Random Access Memory (SRAM) devices organized as 262,144 words × 16 or 18 bits and incorporate a pipeline for highest frequency on any given technology.

Timing for this device is compatible with existing Pentium synchronous cache specifications. This architecture is suited for ASIC, DSP (TMS320C6X), and PowerPC-based systems in computing, datacomm, instrumentation, and telecommunications systems.

Fast cycle times of 6/6.7/7.5/10 ns with clock access times (t_{CP}) of 3.5/3.5/3.8/5.0 ns enable 167, 150, 133 and 100 MHz bus frequencies. Three chip enable inputs permit easy memory expansion. Burst operation is initiated in one of two ways: the controller address strobe (\overline{ADSC}), or the processor address strobe (\overline{ADSP}). The burst advance pin (\overline{ADV}) allows subsequent internally generated burst addresses.

Read cycles are initiated with \overline{ADSP} (regardless of \overline{WE} and \overline{ADSC}) using the new external address clocked into the on-chip address register when \overline{ADSP} is sampled LOW, the chip enables are sampled active, and the output buffer is enabled with \overline{OE} . In a read operation the data accessed by the current address, registered in the address registers by the positive edge of CLK, are carried to the data-out registers and driven on the output pins on the next positive edge of CLK. \overline{ADV} is ignored on the clock edge that samples \overline{ADSP} asserted, but is sampled on all subsequent clock edges. Address is incremented internally for the next access of the burst when \overline{WE} is sampled HIGH, \overline{ADV} is sampled LOW, and both address strobes are HIGH. Burst operation is selectable with the MODE input. With MODE unconnected or driven HIGH, burst operations use a Pentium count sequence. With MODE driven LOW the device uses a linear count sequence, suitable for PowerPC and many other applications.

Write cycles are performed by disabling the output buffers with \overline{OE} and asserting a write command. A global write enable \overline{GWE} writes all 32 bits regardless of the state of individual $BW[a:d]$ inputs. Alternately, when \overline{GWE} is HIGH, one or more bytes may be written by asserting \overline{BWE} and the appropriate individual byte BW signal(s).

\overline{BWN} is ignored on the clock edge that samples \overline{ADSP} LOW, but is sampled on all subsequent clock edges. Output buffers are disabled when \overline{BWN} is sampled LOW (regardless of \overline{OE}). Data is clocked into the data input register when \overline{BWN} is sampled LOW. Address is incremented internally to the next burst of address if \overline{BWN} and \overline{ADV} are sampled LOW.

Read or write cycles may also be initiated with \overline{ADSC} instead of \overline{ADSP} . The differences between cycles initiated with \overline{ADSC} and \overline{ADSP} follow.

- \overline{ADSP} must be sampled HIGH when \overline{ADSC} is sampled LOW to initiate a cycle with \overline{ADSC} .
- \overline{WE} signals are sampled on the clock edge that samples \overline{ADSC} LOW (and \overline{ADSP} HIGH).
- Master chip select $\overline{CE0}$ blocks \overline{ADSP} , but not \overline{ADSC} .

The AS7C3256PFS16A and AS7C3256PFS18A operate from a 3.3V supply. I/Os use a separate power supply that can operate at 2.5V or .3V. These devices are available in a 100-pin 14×20 mm TQFP packaging.

Parameter	Symbol	Signals	Test conditions	Max	Unit
Input capacitance	C_{IN}	Address and control pins	$V_{in} = 0V$	4	pF
I/O capacitance	$C_{I/O}$	I/O pins	$V_{in} = V_{out} = 0V$	5	pF

\overline{GWE}	\overline{BWE}	\overline{BWN}	Function
L	X	X	Write all Bytes
H	L	L	Write Byte(s)n
H	H	X	Read
H	L	H	Read

Key: X = Don't Care, L = LOW, H = HIGH



Signal	I/O	Properties	Description
CLK	I	CLOCK	Clock. All inputs except \overline{OE} are synchronous to this clock.
A0–A17	I	SYNC	Address. Sampled when all chip enables are active and \overline{ADSC} or \overline{ADSP} are asserted.
DQ[a,b,c,d]	I/O	SYNC	Data. Driven as output when the chip is enabled and \overline{OE} is active.
$\overline{CE0}$	I	SYNC	Master chip enable. Sampled on clock edges when \overline{ADSP} or \overline{ADSC} is active. When $\overline{CE0}$ is inactive, \overline{ADSP} is blocked. Refer to the SYNCHRONOUS TRUTH TABLE for more information.
$\overline{CE1}$, $\overline{CE2}$	I	SYNC	Synchronous chip enables. Active HIGH and active LOW, respectively. Sampled on clock edges when \overline{ADSC} is active or when $\overline{CE1}$ and \overline{ADSP} are active.
\overline{ADSP}	I	SYNC	Address strobe (processor). Asserted LOW to load a new address or to enter standby mode.
\overline{ADSC}	I	SYNC	Address strobe (controller). Asserted LOW to load a new address or to enter standby mode.
\overline{ADV}	I	SYNC	Burst advance. Asserted LOW to continue burst read/write.
\overline{GWE}	I	SYNC	Global write enable. Asserted LOW to write all 36 bits. When HIGH, \overline{BWE} and $\overline{BW[a:b]}$ control write enable.
\overline{BWE}	I	SYNC	Byte write enable. Asserted LOW with $\overline{GWE} = \text{HIGH}$ to enable effect of $\overline{BW[a:b]}$ inputs.
$\overline{BW[a,b]}$	I	SYNC	Write enables. Used to control write of individual bytes when $\overline{GWE} = \text{HIGH}$ and $\overline{BWE} = \text{LOW}$. If any of $\overline{BW[a:b]}$ is active with $\overline{GWE} = \text{HIGH}$ and $\overline{BWE} = \text{LOW}$ the cycle is a write cycle. If all $\overline{BW[a:b]}$ are inactive, the cycle is a read cycle.
\overline{OE}	I	ASYN	Asynchronous output enable. I/O pins are driven when \overline{OE} is active and the chip is synchronously enabled.
$\overline{LE0}$	I	STATIC default = HIGH	Count mode. When driven HIGH, count sequence follows Intel XOR convention. When driven LOW, count sequence follows linear convention. This signal is internally pulled HIGH.
FT	I	STATIC default = HIGH	Flow-through mode. When LOW, enables single register flow-through mode. Connect to V_{DD} if unused or for pipelined operation. This signal is internally pulled HIGH.
ZZ	I	ASYN	Sleep. Places device in low power mode; data is retained. Connect to GND if unused.

Parameter	Symbol	Min	Max	Unit
Power supply voltage relative to GND	V_{DD} , V_{DDQ}	-0.5	+4.6	V
Input voltage relative to GND (input pins)	V_{IN}	-0.5	$V_{DD} + 0.5$	V
Input voltage relative to GND (I/O pins)	V_{IN}	-0.5	$V_{DDQ} + 0.5$	V
Power dissipation	P_D	–	1.4	W
DC output current	I_{OUT}	–	50	mA
Storage temperature (plastic)	T_{stg}	-65	+150	°C
Temperature under bias	T_{bias}	-65	+150	°C

NOTE: Stresses greater than those listed under Absolute Maximum Ratings may cause permanent damage to the device. This is a stress rating only and functional operation of the device at these or any other conditions outside those indicated in the operational sections of this specification is not implied. Exposure to absolute maximum rating conditions may affect reliability.



CE0	CE1	CE2	ADSP	ADSC	ADV	WRITE _n [†]	OE	Address accessed	CLK	Operation	DQ
H	X	X	X	L	X	X	X	NA	L to H	Deselect	Hi-Z
L	L	X	L	X	X	X	X	NA	L to H	Deselect	Hi-Z
L	L	X	H	L	X	X	X	NA	L to H	Deselect	Hi-Z
L	X	H	L	X	X	X	X	NA	L to H	Deselect	Hi-Z
L	X	H	H	L	X	X	X	NA	L to H	Deselect	Hi-Z
L	H	L	L	X	X	F	L	External	L to H	Begin read	Hi-Z
L	H	L	L	X	X	F	H	External	L to H	Begin read	Hi-Z
L	H	L	H	L	X	F	L	External	L to H	Begin read	Hi-Z
L	H	L	H	L	X	F	H	External	L to H	Begin read	Hi-Z
X	X	X	H	H	L	F	L	Next	L to H	Cont. read	DQ
X	X	X	H	H	L	F	H	Next	L to H	Cont. read	Hi-Z
X	X	X	H	H	H	F	L	Current	L to H	Suspend read	DQ
X	X	X	H	H	H	F	H	Current	L to H	Suspend read	Hi-Z
H	X	X	X	H	L	F	L	Next	L to H	Cont. read	DQ
H	X	X	X	H	L	F	H	Next	L to H	Cont. read	Hi-Z
H	X	X	X	H	H	F	L	Current	L to H	Suspend read	DQ
H	X	X	X	H	H	F	H	Current	L to H	Suspend read	Hi-Z
L	H	L	H	L	X	T	X	External	L to H	Begin write	Hi-Z
X	X	X	H	H	L	T	X	Next	L to H	Cont. write	Hi-Z
H	X	X	X	H	L	T	X	Next	L to H	Cont. write	Hi-Z
X	X	X	H	H	H	T	H	Current	L to H	Suspend write	Hi-Z
H	X	X	X	H	H	T	H	Current	L to H	Suspend write	Hi-Z

Key: X = Don't Care, L = LOW, H = HIGH.

[†]See Write enable truth table for more information.



Parameter		Symbol	Min	Nominal	Max	Unit
Supply voltage		V _{DD}	3.135	3.3	3.465	V
		GND	0.0	0.0	0.0	
3.3V I/O supply voltage		V _{DDQ}	3.135	3.3	3.465	V
		GND _Q	0.0	0.0	0.0	
2.5V I/O supply voltage		V _{DDQ}	2.35	2.5	2.65	V
		GND _Q	0.0	0.0	0.0	
Input voltages [†]	Address and control pins	V _{IH}	2.0	–	V _{DD} + 0.3	V
		V _{IL}	-0.5*	–	0.8	
	I/O pins	V _{IH}	2.0	–	V _{DDQ} + 0.3	V
		V _{IL}	-0.5*	–	0.8	
Ambient operating temperature		T _A	0	–	70	°C

* V_{IL min} = -2.0V for pulse width less than 0.2 × t_{RC}

[†] Input voltage ranges apply to 3.3V I/O operation. For 2.5V I/O operation, contact factory for input specifications.

Description	Conditions		Symbol	Typical	Units
Thermal resistance (Junction to Ambient) *	Test conditions follow standard test methods and procedures for measuring thermal impedance, per EIA/JESD51.	1-layer	θ _{JA}	40	°C/W
		4-layer	θ _{JA}	22	°C/W
Thermal resistance (Junction to Top of Case) *			θ _{JC}	8	°C/W

*This parameter is sampled.

Description	Conditions		Symbol	Typical	Units
Junction to Ambient (airflow of 1m/s) *	Test conditions follow standard test methods and procedures for measuring thermal impedance, per EIA/JESD51.	1-layer	θ _{JA}	40	°C/W
		4-layer	θ _{JA}	25	°C/W
Junction to Top of Case*			θ _{JC}	9	°C/W
Junction to Bottom of Bumps*			θ _{JB}	17	°C/W

*This parameter is sampled.



Parameter	Symbol	Test conditions	-166		-150		-133		-100		Unit
			Min	Max	Min	Max	Min	Max	Min	Max	
Input leakage current	$ I_{LI} $	$V_{DD} = \text{Max}, V_{in} = \text{GND to } V_{DD}$	-	2	-	2	-	2	-	2	μA
Output leakage current	$ I_{LO} $	$\overline{\text{OE}} \geq V_{IH}, V_{DD} = \text{Max}, V_{out} = \text{GND to } V_{DD}$	-	2	-	2	-	2	-	2	μA
Operating power supply current	I_{CC}	$\overline{\text{CE}} = V_{IL}, \text{CE} = V_{IH}, \overline{\text{CE}} = V_{IL}, f = f_{max}, I_{out} = 0 \text{ mA}$	-	450	-	400	-	350	-	300	mA
Standby power supply current	I_{SB}	Deselected, $f = f_{max}$	-	90	-	80	-	70	-	60	mA
	I_{SB1}	Deselected, $f = 0$, all $V_{IN} \leq 0.2\text{V}$ or $\geq V_{DD} - 0.2\text{V}$	-	5	-	5	-	5	-	5	
Output voltage	V_{OL}	$I_{OL} = 8 \text{ mA}, V_{DDQ} = 3.465\text{V}$	-	0.4	-	0.4	-	0.4	-	0.4	V
	V_{OH}	$I_{OH} = -4 \text{ mA}, V_{DDQ} = 3.135\text{V}$	2.4	-	2.4	-	2.4	-	2.4	-	

Parameter	Symbol	Test conditions	-166		-150		-133		-100		Unit
			Min	Max	Min	Max	Min	Max	Min	Max	
Output leakage current	$ I_{LO} $	$\overline{\text{OE}} \geq V_{IH}, V_{DD} = \text{Max}, V_{out} = \text{GND to } V_{DD}$	-1	1	-1	1	-1	1	-1	1	μA
Output voltage	V_{OL}	$I_{OL} = 2 \text{ mA}, V_{DDQ} = 2.65\text{V}$	-	0.7	-	0.7	-	0.7	-	0.7	V
	V_{OH}	$I_{OH} = -2 \text{ mA}, V_{DDQ} = 2.35\text{V}$	1.7	-	1.7	-	1.7	-	1.7	-	



Parameter	Symbol	-3.5		-3.8		-4		-5		Unit	Notes
		Min	Max	Min	Max	Min	Max	Min	Max		
Clock frequency	F _{MAX}	-	166	-	150	-	133	-	100	MHz	1
Cycle time (pipelined mode)	t _{CYC}	6	-	6.6	-	7.5	-	10	-	ns	
Cycle time (flow-through mode)	t _{CYCF}	10	-	10	-	12	-	15	-	ns	
Clock access time (pipelined mode)	t _{CD}	-	3.5	-	3.8	-	4.0	-	5.0	ns	
Clock access time (flow-through mode)	t _{CDF}	-	8	-	8	-	9	-	12	ns	
Output enable LOW to data valid	t _{OE}	-	3.5	-	3.5	-	3.8	-	5.0	ns	
Clock HIGH to output Low Z	t _{LZC}	0	-	0	-	0	-	0	-	ns	8
Data output invalid from clock HIGH	t _{OH}	1.5	-	1.5	-	1.5	-	1.5	-	ns	8
Output enable LOW to output Low Z	t _{LZOE}	0	-	0	-	0	-	0	-	ns	8
Output enable HIGH to output High Z	t _{HZOE}	-	3.0	-	3.0	-	3.8	-	5.0	ns	8
Clock HIGH to output High Z	t _{HZC}	-	3.0	-	3.3	-	3.3	-	4.5	ns	8
Clock HIGH to output High Z	t _{HZCN}	-	1.5	-	1.5	-	2	-	2.5	ns	1,9
Clock HIGH pulse width	t _{CH}	2.0	-	2.0	-	2.0	-	2.5	-	ns	
Clock LOW pulse width	t _{CL}	2.0	-	2.0	-	2.0	-	2.5	-	ns	
Address and Control setup to clock HIGH	t _{AS}	1.5	-	1.5	-	1.5	-	1.5	-	ns	
Data setup to clock HIGH	t _{DS}	1.5	-	1.5	-	1.5	-	1.5	-	ns	
Write setup to clock HIGH	t _{WS}	1.5	-	1.5	-	1.5	-	1.5	-	ns	
Chip select setup to clock HIGH	t _{CSS}	1.5	-	1.5	-	1.5	-	1.5	-	ns	
Address hold from clock HIGH	t _{AH}	0.5	-	0.5	-	0.5	-	0.5	-	ns	
Data hold from clock HIGH	t _{DH}	0.5	-	0.5	-	0.5	-	0.5	-	ns	
Write hold from clock HIGH	t _{WH}	0.5	-	0.5	-	0.5	-	0.5	-	ns	
Chip select hold from clock HIGH	t _{CSH}	0.5	-	0.5	-	0.5	-	0.5	-	ns	
Output rise time (0 pF load)	t _R	1.5	-	1.5	-	1.5	-	1.5	-	V/ns	1
Output fall time (0 pF load)	t _F	1.5	-	1.5	-	1.5	-	1.5	-	V/ns	1

See "Notes" on page 11.

Rising input

Falling input

Undefined/don't care

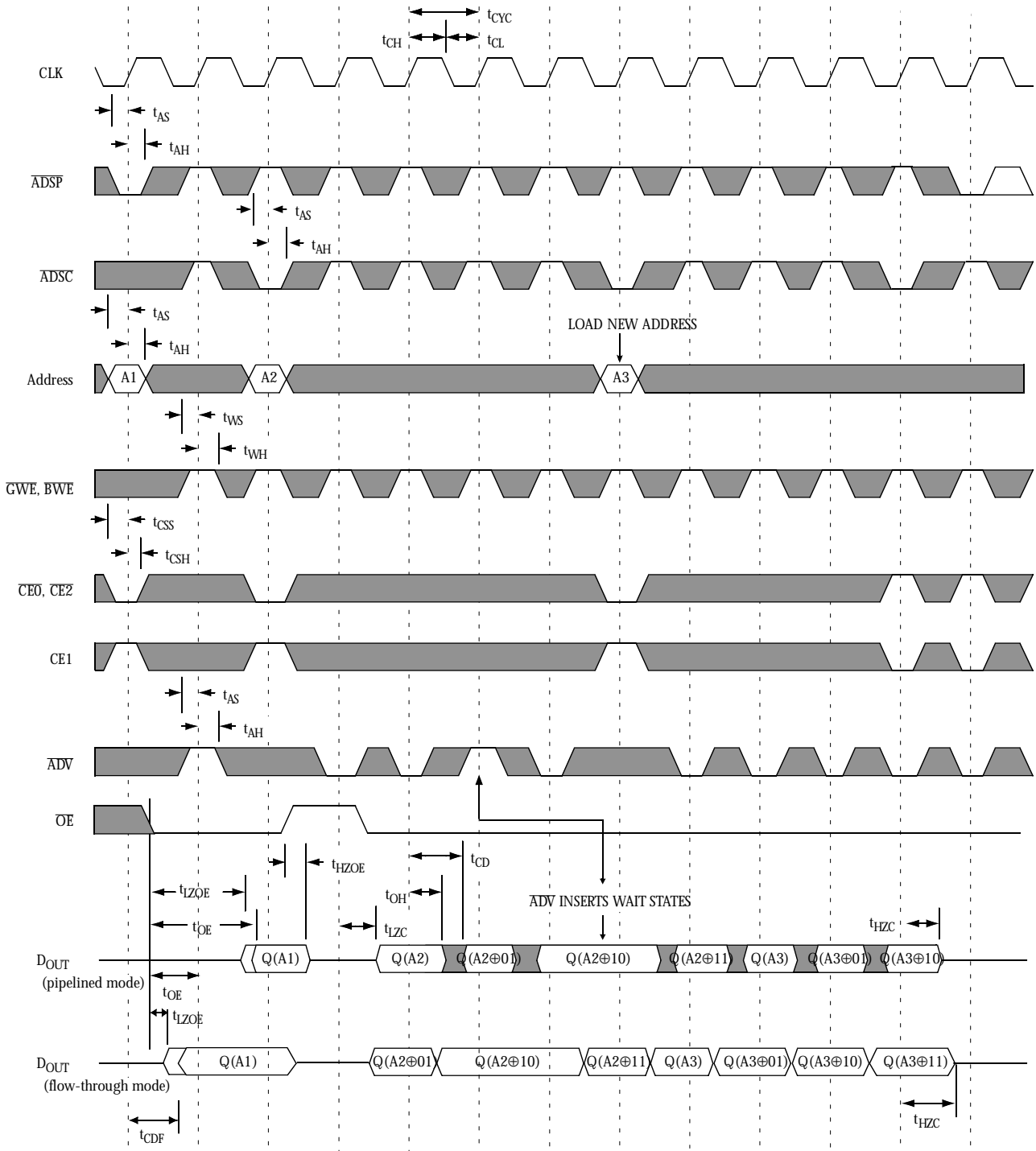

Note: \oplus = XOR when MODE = HIGH/No Connect; \oplus = ADD when MODE = LOW.
— don't care.

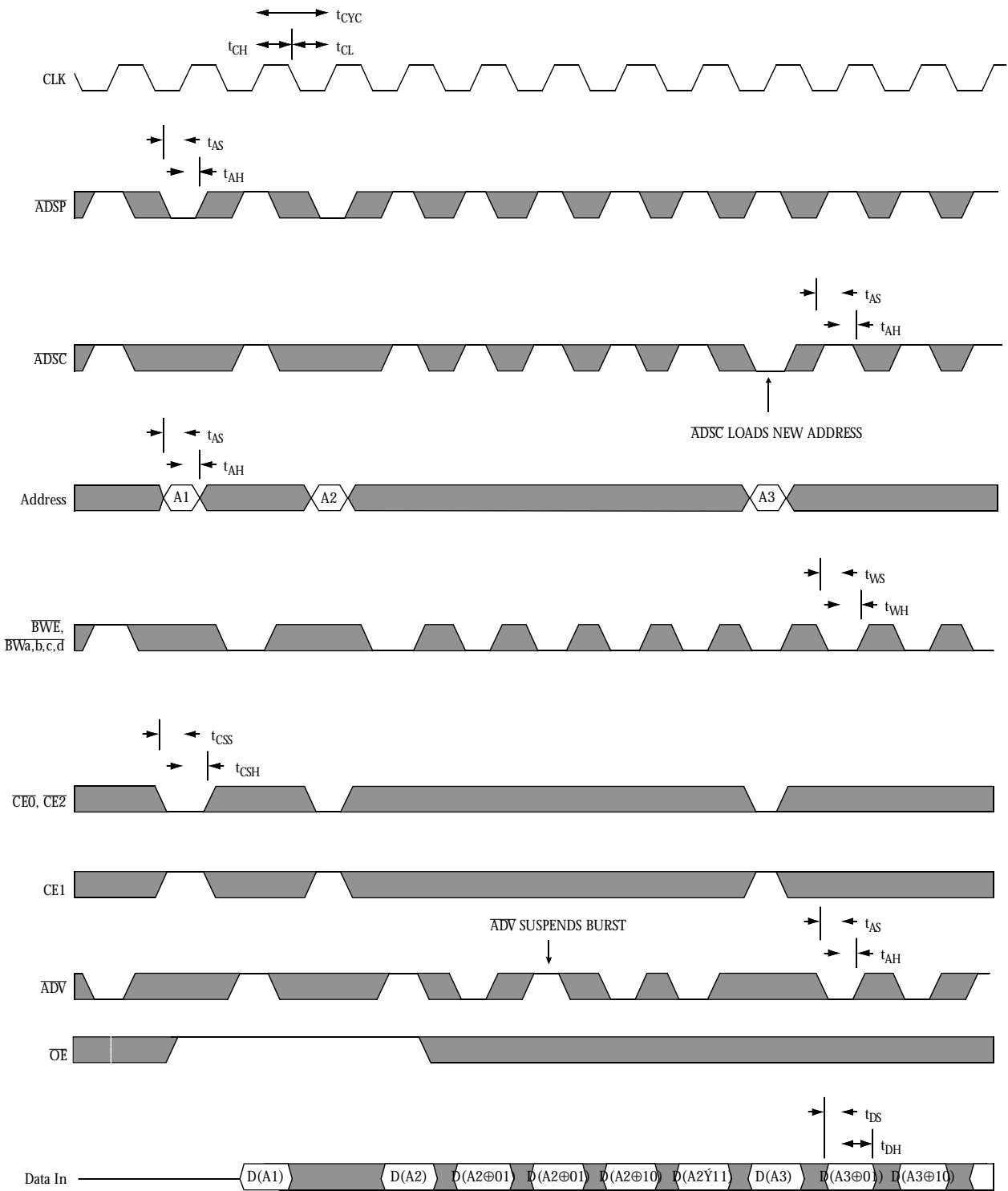

Note: ⊕ = XOR when MODE = HIGH/No Connect; ⊕ = ADD when MODE = LOW.

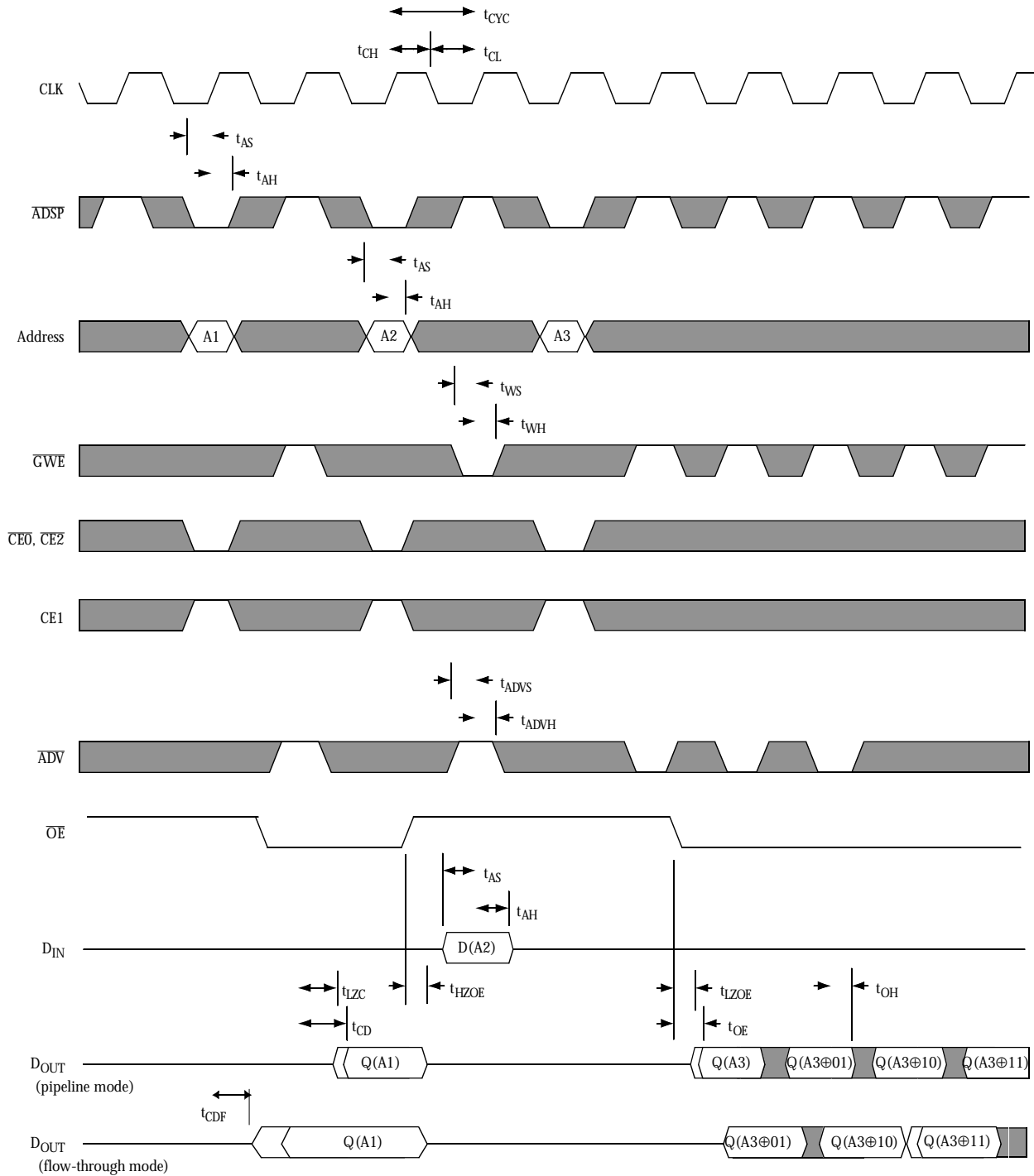

Note: \oplus = XOR when MODE = HIGH/No Connect; \oplus = ADD when MODE = LOW.



- 1 This parameter is guaranteed but not tested.
- 2 For test conditions, see AC Test Conditions, Figures A, B, C.
- 3 This parameter is sampled and not 100% tested.
- 4 This is a synchronous device. All addresses must meet the specified setup and hold times for all rising edges of CLK. All other synchronous inputs must meet the setup and hold times with stable logic levels for all rising edges of CLK when chip is enabled.
- 5 Typical values measured at 3.3V, 25°C and 10 ns cycle time.
- 6 I_{CC} given with no output loading. I_{CC} increases with faster cycle times and greater output loading.
- 7 Transitions are measured ± 500 mV from steady state voltage. Output loading specified with $C_L = 5$ pF as in Figure C.
- 8 t_{HZOE} is less than t_{LZOE} ; and t_{HZC} is less than t_{LZC} at any given temperature and voltage.
- 9 t_{HZCN} is a 'no load' parameter to indicate exactly when SRAM outputs have stopped driving.

- Output Load: see Figure B, except for t_{LZC} , t_{LZOE} , t_{HZOE} , t_{HZC} see Figure C.
- Input pulse level: GND to 3V. See Figure A.
- Input rise and fall time (Measured at 0.3V and 2.7V): 2 ns. See Figure A.
- Input and output timing reference levels: 1.5V.

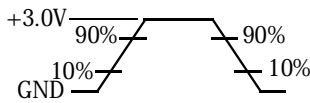

Figure A: Input waveform

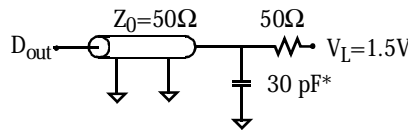

Figure B: Output load (A)

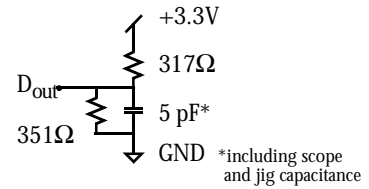

Figure C: Output load (B)

Package	Width	166 MHz	150 MHz	133 MHz	100 MHz
TQFP	×16	AS7C3256PFS16A-3.5TQC	AS7C3256PFS16A-3.8TQC	AS7C3256PFS16A-4TQC	AS7C3256PFS16A-5TQC
TQFP	×18	AS7C3256PFS18A-3.5TQC	AS7C3256PFS18A-3.8TQC	AS7C3256PFS18A-4TQC	AS7C3256PFS18A-5TQC

AS7C	3	256K36	P	S	16, 18	-XX	XX	C
SRAM prefix	Operating voltage	Part number, organization	Timing P=PB SRAM	S = Single-cycle deselect	Organization	Access time (ns)	Package: TQ = TQFP	Commercial temperature, 0°C to 70 °C