



PowerPC 740 and PowerPC 750 Microprocessor Datasheet

CMOS 0.20 μm Copper Technology, PID-8p, PPC740L and PPC750L, dd3.2

Version 1.02

12/8/99

IBM Microelectronics Division



Notices

Before using this information and the product it supports, be sure to read the general information on the back cover of this book.

Trademarks

The following are trademarks of International Business Machines Corporation in the United States, or other countries, or both:

IBM
AIX

IBM Logo
PowerPC 750

PowerPC
PowerPC 740

Other company, product, and service names may be trademarks or service marks of others.

This document contains information on a new product under development by IBM. IBM reserves the right to change or discontinue this product without notice.

© International Business Machines Corporation 1999.
Portions hereof ©International Business Machines Corporation, 1991-1999.
All rights reserved.



Table of Contents

Preface	4
New Features for dd3.x	4
Overview	5
Features	6
General Parameters	8
Electrical and Thermal Characteristics	9
DC Electrical Characteristics	9
AC Electrical Characteristics	13
Clock AC Specifications	13
60x Bus Input AC Specifications	14
60x Bus Output AC Specifications	16
L2 Clock AC Specifications	18
L2 Bus Input AC Specifications	20
L2 Bus Output AC Specifications	21
IEEE 1149.1 AC Timing Specifications	22
PowerPC 740 Microprocessor Pin Assignments	24
PowerPC 740 Microprocessor Pinout Listings	25
PowerPC 740 Package	28
Mechanical Dimensions of the PowerPC 740 255 CBGA Package	29
PowerPC 750 Microprocessor Pin Assignments	30
PowerPC 750 Package	33
Mechanical Dimensions of the PowerPC 750 360 CBGA Package	34
System Design Information	36
PLL Configuration	36
PLL Power Supply Filtering	37
Decoupling Recommendations	37
Connection Recommendations	37
Output Buffer DC Impedance	38
Pull-up Resistor Requirements	39
Thermal Management Information	40
Internal Package Conduction Resistance	41
Heat Sink Selection Example	44
Ordering Information	46



Preface

The PowerPC 740 and PowerPC 750 are members of the PowerPC family of reduced instruction set computer (RISC) microprocessors. The PPC740L and PPC750L microprocessors are the PID-8p implementations of the PowerPC 740 and PowerPC 750 in IBM CMOS 7S 0.20 μ m copper technology. They are referred to in the body of this document as “740” and “750.”

Information in this document does not apply to implementations of the PowerPC 740 and PowerPC 750 in other technologies, such as the PID-8t.

The information in this document is also specific to revision level dd3.2 of the (PID-8p) PPC740L and PPC750L, and does not apply to previous revisions.

This document is generally written in terms of the 750. Unless otherwise noted, information that applies to the 750 also applies to the 740. Exceptions are detailed. The 740 die is identical to the 750 die, but the 740 package and pinout are different, in that the 740 does not pin out the L2 interface.

The 740 uses the same die as the 750, but the 740 does not pin out the L2 cache interface.

New Features for dd3.x

- Selectable I/O voltages on 60X bus and L2 bus. See Table , “Recommended Operating Conditions,” on page 9. Older revs must leave these pins “no connect” or “tied high” for 3.3v I/Os. Ac timings are the same for all I/O voltages modes unless otherwise noted.
- 60X bus to core frequency now also supports the 10x ratio. See Table , “PLL Configuration,” on page 36.
- Extra output hold on the 60x bus by L2_TSTCLK pin tied low is no longer available. The L2_TSTCLK pin must now be tied to OV_{DD} for normal operation. See Table , “60X Bus Output AC Timing Specifications for the 750¹,” on page 16.

Overview

The 750 is targeted for high performance, low power systems and supports the following power management features: doze, nap, sleep, and dynamic power management. The 750 consists of a processor core and an internal L2 Tag combined with a dedicated L2 cache interface and a 60x bus. The L2 cache is not available with the 740.

Figure 1 shows a block diagram of the 750.

Figure 1. 750 Block Diagram

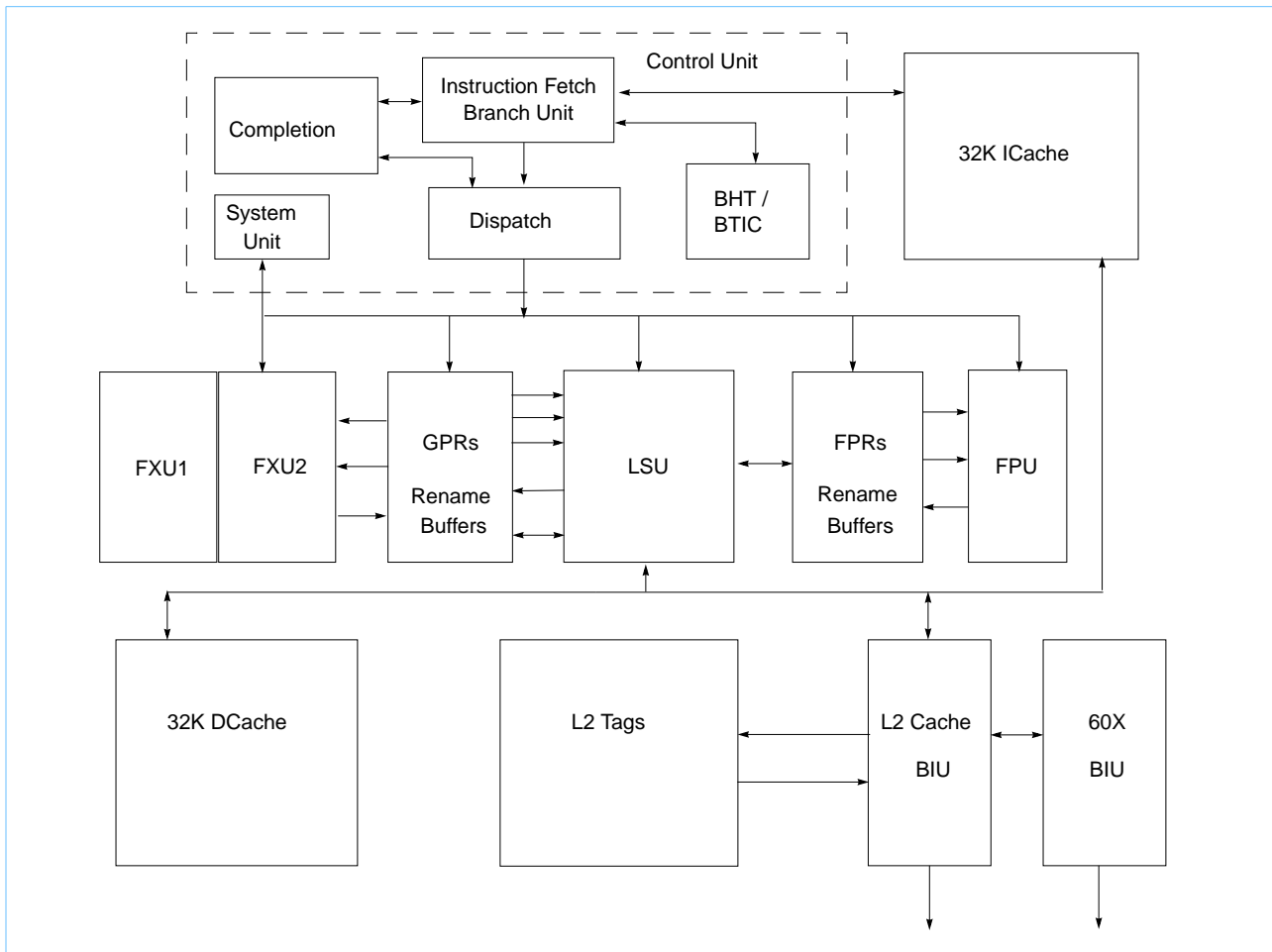

Features

This section summarizes features of the implementation of the PowerPC 750 architecture. For details, see the *PowerPC 740 and PowerPC750 User's Manual*.

- Branch processing unit
 - Four instructions fetched per clock.
 - One branch processed per cycle (plus resolving 2 speculations).
 - Up to 1 speculative stream in execution, 1 additional speculative stream in fetch.
 - 512-entry branch history table (BHT) for dynamic prediction.
 - 64-entry, 4-way set associative branch target instruction cache (BTIC) for eliminating branch delay slots.
- Dispatch unit
 - Full hardware detection of dependencies (resolved in the execution units).
 - Dispatch two instructions to six independent units (system, branch, load/store, fixed-point unit 1, fixed-point unit 2, or floating-point).
 - Serialization control (predispatch, postdispatch, execution, serialization).
- Decode
 - Register file access.
 - Forwarding control.
 - Partial instruction decode.
- Load/store unit
 - One cycle load or store cache access (byte, half word, word, double word).
 - Effective address generation.
 - Hits under misses (one outstanding miss).
 - Single-cycle misaligned access within double word boundary.
 - Alignment, zero padding, sign extend for integer register file.
 - Floating-point internal format conversion (alignment, normalization).
 - Sequencing for load/store multiples and string operations.
 - Store gathering.
 - Cache and TLB instructions.
 - Big and little-endian byte addressing supported.
 - Misaligned little-endian support in hardware.
- Fixed-point units
 - Fixed-point unit 1 (FXU1); multiply, divide, shift, rotate, arithmetic, logical.
 - Fixed-point unit 2 (FXU2); shift, rotate, arithmetic, logical.
 - Single-cycle arithmetic, shift, rotate, logical.
 - Multiply and divide support (multi-cycle).
 - Early out multiply.
- Floating-point unit
 - Support for IEEE-754 standard single- and double-precision floating-point arithmetic.
 - 3 cycle latency, 1 cycle throughput, single-precision multiply-add.
 - 3 cycle latency, 1 cycle throughput, double-precision add.
 - 4 cycle latency, 2 cycle throughput, double-precision multiply-add.
 - Hardware support for divide.
 - Hardware support for denormalized numbers.
 - Time deterministic non-IEEE mode.



- System unit
 - Executes CR logical instructions and miscellaneous system instructions.
 - Special register transfer instructions.
- Cache structure
 - 32K, 32-byte line, 8-way set associative instruction cache.
 - 32K, 32-byte line, 8-way set associative data cache.
 - Single-cycle cache access.
 - Pseudo-LRU replacement.
 - Copy-back or write-through data cache (on a page per page basis).
 - Supports all PowerPC memory coherency modes.
 - Non-blocking instruction and data cache (one outstanding miss under hits).
 - No snooping of instruction cache.
- Memory management unit
 - 128 entry, 2-way set associative instruction TLB.
 - 128 entry, 2-way set associative data TLB.
 - Hardware reload for TLB's.
 - 4 instruction BAT's and 4 data BATs.
 - Virtual memory support for up to 4 exabytes (2^{52}) virtual memory.
 - Real memory support for up to 4 gigabytes (2^{32}) of physical memory.
- Level 2 (L2) cache interface (Not available on the 740)
 - Internal L2 cache controller and 4K-entry tags; external data SRAMs.
 - 256K, 512K, and 1 Mbyte 2-way set associative L2 cache support.
 - Copy-back or write-through data cache (on a page basis, or for all L2).
 - 64-byte (256K/512K) and 128-byte (1-Mbyte) sectored line size.
 - Supports flow-through (reg-buf) synchronous burst SRAMs, pipelined (reg-reg) synchronous burst SRAMs, and pipelined (reg-reg) late-write synchronous burst SRAMs with optional parity checking.
 - Supports Core-to-L2 frequency divisors of $\div 1$, $\div 1.5$, $\div 2$, $\div 2.5$, and $\div 3$. The 750 supports the L2 frequency range specified in Section "L2 Clock AC Specifications," on page 18. For higher L2 frequencies, please contact ppcsupp@us.ibm.com.
- Bus interface
 - Compatible with 60x processor interface.
 - 32-bit address bus with optional parity checking.
 - 64-bit data bus (can be operated in 32-bit data bus mode) with optional parity checking.
 - Bus-to-core frequency multipliers from 2x to 10x. See the Table , "PLL Configuration," on page 36.
- Integrated power management
 - Low-power 2.0/3.3V design.
 - Three static power saving modes: doze, nap, and sleep.
 - Automatic dynamic power reduction when internal functional units are idle.
- Integrated Thermal Management Assist Unit
 - On-chip thermal sensor and control logic.
 - Thermal Management Interrupts for software regulation of junction temperature.
- Testability
 - JTAG interface.

General Parameters

The following list provides a summary of the general parameters of the 750.

Technology	0.20 μm CMOS (general lithography), six-layer copper metallization 0.12 \pm 0.04 μm L_{eff}
Die Size	5.14mm x 7.78mm (40mm ²)
Transistor count	6.35 million
Logic design	Fully-static
Package	740: Surface mount 21x21mm, 255-lead ceramic ball grid array (CBGA) 750: Surface mount 25x25mm, 360-lead ceramic ball grid array (CBGA)
PPC 740/PPC 750 core power supply	2V Nominal (see Application Conditions)
I/O power supply	3.3V 2.5V, or 1.8V Nominal Selectable)



Electrical and Thermal Characteristics

DC Electrical Characteristics

The 750 60x bus power supply can be either 3.3V, 2.5V, or 1.8V nominal; likewise, the L2 power supply can be either 3.3V, 2.5V, or 1.8V nominal. See the pinout listing for more information

Absolute Maximum Ratings See Notes

Characteristic	Symbol	Value	Unit
Core supply voltage	V_{DD}	-0.3 to 2.5	V
PLL supply voltage	AV_{DD}	-0.3 to 2.5	V
L2 DLL supply voltage	$L2AV_{DD}$	-0.3 to 2.5	V
60x bus supply voltage	$OV_{DD(3.3V)}$	-0.3 to 3.6	V
	$OV_{DD(2.5V)}$	-0.3 to 2.8	
	$OV_{DD(1.8V)}$	-0.3 to 2.1	
L2 bus supply voltage	$L2OV_{DD}$	-0.3 to 3.6	V
Input voltage	$V_{IN(3.3V)}$	-0.3 to 3.6	V
	$V_{IN(2.5V)}$	-0.3 to 2.8	
	$V_{IN(1.8V)}$	-0.3 to 2.1	
Storage temperature range	T_{STG}	-55 to 150	$^{\circ}\text{C}$

Note:

1. Functional and tested operating conditions are given in Table "Recommended Operating Conditions," below. Absolute maximum ratings are stress ratings only, and functional operation at the maximums is not guaranteed. Stresses beyond those listed may affect device reliability or cause permanent damage to the device.
2. **Caution:** V_{IN} must not exceed OV_{DD} by more than 0.3V at any time, including during power-on reset. This is a DC specification only. V_{IN} overshoot transients up to $OV_{DD}+1V$, and undershoots down to $GND-1V$ (both measured with the 740 in the circuit) are allowed for up to 5ns.
3. **Caution:** OV_{DD} must not exceed V_{DD}/AV_{DD} by more than 2.0V at any time during normal operation. On power up and power down, OV_{DD} is allowed to exceed V_{DD}/AV_{DD} by up to 3.3V for up to 20 ms, or by up to 2.5V for 40 ms. Excursions beyond 40 ms or 3.3V are not allowed.
4. **Caution:** V_{DD}/AV_{DD} must not exceed OV_{DD} by more than 0.4V during normal operation. On power up and power down, V_{DD}/AV_{DD} is allowed to exceed OV_{DD} by up to 1.0V for up to 20 ms, or by up to 0.7V for 40 ms. Excursions beyond 40 ms or 1.0V are not allowed.

Recommended Operating Conditions

Characteristic	Symbol	Value	Unit	Notes
Core supply voltage	V_{DD}	2.0	V	1, 2
PLL supply voltage	AV_{DD}	V_{DD}	V	1
L2DLL supply voltage	$L2AV_{DD}$	V_{DD}	V	1
60x bus supply voltage, pin W1 tied high	$OV_{DD(3.3V)}$	3.135 to 3.465	V	1
60x bus supply voltage pin W1 tied to \overline{HRESET}	$OV_{DD(2.5V)}$	2.375 to 2.625	V	1
60x bus supply voltage, pin W1 tied to GND	$OV_{DD(1.8V)}$	1.71 to 1.89	V	1
L2 bus supply voltage, pin A19 tied high	$L2OV_{DD(3.3V)}$	3.135 to 3.465	V	1
L2 bus supply voltage, pin A19 tied to \overline{HRESET}	$L2OV_{DD(2.5V)}$	2.375 to 2.625	V	1

Note:

1. These are recommended and tested operating conditions. Proper device operation outside of these conditions is not guaranteed.
2. V_{DD} and T_J are specified by the Application Conditions designator in the part number. See the Part Number Key on Page 43 for more information.



PowerPC 740 and PowerPC 750 Microprocessor
CMOS 0.20 μ m Copper Technology, PID-8p, PPC740L and PPC750L, dd3.2

Recommended Operating Conditions

Characteristic	Symbol	Value	Unit	Notes
L2 bus supply voltage, pin A19 tied to GND	L2OV _{DD(1.8V)}	1.71 to 1.89	V	1
Input voltage (Under AC conditions, inputs must go rail-to-rail for maximum AC timing performance.)	V _{IN(60X)}	GND to OV _{DD}	V	1
	V _{IN(L2)}	GND to L2OV _{DD}	V	1
Die-junction temperature	T _J	-40 to 105	°C	1, 2

Note:

1. These are recommended and tested operating conditions. Proper device operation outside of these conditions is not guaranteed.
2. V_{DD} and T_J are specified by the Application Conditions designator in the part number. See the Part Number Key on Page 43 for more information.

Package Thermal Characteristics¹

Characteristic	Symbol	740	750	Unit
Thermal resistance, junction-to-case (top surface of die) typical	θ_{JC}	0.03	0.03	°C/W
Thermal resistance, junction-to-balls, typical	θ_{JB}	3.8 - 7.1 ²	3.8 - 7.6 ²	°C/W
Thermal resistance, junction-to-ambient, at air-flow, no heat sink, typical	50 FPM	16.0	15.1	°C/W
	100 FPM	15.4	16.4	°C/W
	150 FPM	14.9	14.2	°C/W
	200 FPM	14.4	13.7	°C/W
Package Size		21 x 21	25 x 25	mm ²
Die Size		5.12 x 7.78	5.12 x 7.78	mm ²

Note:

1. Refer to Section "Thermal Management Information," on page 40 for more information about thermal management.
2. 3.8 °C/W is theoretical θ_{JB} mounted to infinite heat sink. The larger number applies to module mounted to a 1.8 mm thick, 2P card using 1 oz. copper power/gnd planes, with effective area for heat transfer of 75mm x 75mm.

The 750 incorporates a thermal management assist unit (TAU) composed of a thermal sensor, digital-to-analog converter, comparator, control logic, and dedicated special-purpose registers (SPRs). See the *PowerPC 740 and PowerPC 750 User's Manual* for more information on the use of this feature. Specifications for the thermal sensor portion of the TAU are found in the table below.

Thermal Sensor Specifications

See Table "Recommended Operating Conditions," on page 9, for operating conditions.

Num	Characteristic	Minimum	Maximum	Unit	Notes
1	Temperature range	0	128	°C	1
2	Comparator settling time	20	—	ms	2

Note:

1. The temperature is the junction temperature of the die. The thermal assist unit's (TAU) raw output does not indicate an absolute temperature, but it must be interpreted by software to derive the absolute junction temperature. For information on how to use and calibrate the TAU, contact ppcsupp@us.ibm.com. This specification reflects the temperature span supported by the design.
2. The comparator settling time value must be converted into the number of CPU clocks that need to be written into the THRM3 SPR. For parts with nominal operating frequencies (speed sort) above 266 MHz, the settling time = 20 μ s \times (266/nominal frequency). For example: for 500 MHz parts, settling time = 20 μ s \times (266/500) = 10.6 μ s. It is recommended that the maximum value be set in THRM3 under all conditions.
3. This value is guaranteed by design and is not tested.



Thermal Sensor Specifications

See Table "Recommended Operating Conditions," on page 9, for operating conditions.

Num	Characteristic	Minimum	Maximum	Unit	Notes
3	Resolution	4	—	$^{\circ}$ C	3
4	Drift, all sources	—	.25	LSb	
5	Linearity, error over range	—	1	LSb	
6	Offset error, reducible	—	2	LSb	

Note:

1. The temperature is the junction temperature of the die. The thermal assist unit's (TAU) raw output does not indicate an absolute temperature, but it must be interpreted by software to derive the absolute junction temperature. For information on how to use and calibrate the TAU, contact ppcsupp@us.ibm.com. This specification reflects the temperature span supported by the design.
2. The comparator settling time value must be converted into the number of CPU clocks that need to be written into the THRM3 SPR. For parts with nominal operating frequencies (speed sort) above 266 MHz, the settling time = $20 \mu\text{s} \times (266/\text{nominal frequency})$. For example: for 500 MHz parts, settling time = $20 \mu\text{s} \times (266/500) = 10.6 \mu\text{s}$. It is recommended that the maximum value be set in THRM3 under all conditions.
3. This value is guaranteed by design and is not tested.

DC Electrical Specifications

See Section "Recommended Operating Conditions," on page 9, for operating conditions.

Characteristic	Symbol	Min	Max	Unit	Notes
Input high voltage (all inputs except SYSCLK)	$V_{IH(3.3V)}$	2.0	3.465	V	1,2
	$V_{IH(2.5V)}$	1.75	2.625		
	$V_{IH(1.8V)}$	1.4	1.89		
Input low voltage (all inputs except SYSCLK)	$V_{IL(3.3V)}$	GND	0.8	V	
	$V_{IL(2.5V)}$	GND	0.7		
	$V_{IL(1.8V)}$	GND	0.5		
SYSCLK input high voltage	$CV_{IH(3.3V)}$	2.0	3.465	V	1, 4
	$CV_{IH(2.5V)}$	2.0	2.625		
	$CV_{IH(1.8V)}$	1.5	1.89		
SYSCLK input low voltage	CV_{IL}	—	0.4	V	4
Input leakage current, $V_{IN} = OV_{DD}$	I_{IN}	—	20	μ A	1,2
Hi-Z (off state) leakage current, $V_{in} = OV_{DD}$	I_{TSI}	—	20	μ A	1,2
Output high voltage, $I_{OH} = -6\text{mA}$	$V_{OH(3.3V)}$	2.4	—	V	
Output high voltage, $I_{OH} = -6\text{mA}$	$V_{OH(2.5V)}$	1.9	—	V	
Output high voltage, $I_{OH} = -3\text{mA}$	$V_{OH(1.8V)}$	1.4	—	V	
Output low voltage, $I_{OL} = 6\text{mA}$	V_{OL}	—	0.4	V	
Capacitance, $V_{IN} = 0\text{V}$, $f = 1\text{MHz}$	C_{IN}	—	5.0	pF	2,3

Note:

1. For 60x bus signals, the reference is OV_{DD} , while $L2OV_{DD}$ is the reference for the L2 bus signals.
2. JTAG port signal levels are controlled by the BVSEL pin and are the same as those shown for the 60x bus. $LSSD_MODE$, $L1_TSTCLK$, and $L2TSTCLK$ receiver voltage levels are those shown for $OV_{DD} = 1.8\text{V}$ nominal, regardless of BVSEL. JTAG, $LSSD_MODE$, $L1_TSTCLK$, and $L2TSTCLK$ values in this table are guaranteed by design and characterization, and are not tested.
3. Capacitance values are guaranteed by design and characterization, and are not tested.
4. SYSCLK input high and low voltage: I/O timings are measured using a "rail to rail" SYSCLK; I/O timing may be less favorable if SYSCLK does not travel from GND to OV_{DD} .



PowerPC 740 and PowerPC 750 Microprocessor
CMOS 0.20 μ m Copper Technology, PID-8p, PPC740L and PPC750L, dd3.2

Power Consumption for 740 and 750

See Table "Recommended Operating Conditions," on page 9, for operating conditions

	Actual Processor CPU Frequency									Unit	Notes
	300	333	350	366	375	400	433	466	500		
Full-On Mode											
Typical	3.7	4.0	4.1	4.3	4.4	4.5	5.0	5.5	6.0	W	1,3,4
Maximum	4.5	5.0	5.2	5.5	5.7	6.0	6.3	6.8	7.5	W	1,2,4
Doze Mode											
Maximum	1.7	1.7	1.7	1.8	1.8	1.9	2.1	2.2	2.3	W	1,2,4
Nap Mode											
Maximum	250	250	250	250	250	250	250	250	250	mW	1, 4
Sleep Mode											
Maximum	TBD	TBD	TBD	TBD	TBD	TBD	TBD	TBD	TBD	mW	1, 4
Note:											
<p>1. These values apply for all valid 60x bus and L2 bus ratios. The values do not include I/O Supply Power (OV_{DD} and $L2OV_{DD}$) or PLL/DLL supply power (AV_{DD} and $L2AV_{DD}$). OV_{DD} and $L2OV_{DD}$ power is system dependent, but is typically <10% of V_{DD} power. Worst case power consumption for AV_{DD} = 15mW and $L2AV_{DD}$ = 15mW.</p> <p>2. Maximum power is shown for a system executing worst case benchmark sequences at:</p> <ul style="list-style-type: none"> • $V_{DD} = AV_{DD} = L2V_{DD} = 2.1V$; • $OV_{DD} = L2OV_{DD} = 3.3V$; • $T_j = 65^\circ C$ <p>Maximum power at 85 °C can be derived by adding 0.1 W to the maximum power shown at 65 °C. Maximum power at 105 °C can be derived by adding 0.3 W to the maximum power shown at 65 °C.</p> <p>3. Typical power is an average value shown for a system executing typical applications and benchmark sequences at:</p> <ul style="list-style-type: none"> • $V_{DD} = AV_{DD} = L2AV_{DD} = 2.0V$ (300 through 400 MHz); • $V_{DD} = AV_{DD} = L2AV_{DD} = 2.05V$ (433 through 500 MHz); • $OV_{DD} = L2OV_{DD} = 3.3V$; • $T_j = 45^\circ C$. <p>4. Guaranteed by design and characterization, and is not tested.</p>											

AC Electrical Characteristics

This section provides the AC electrical characteristics for the 750. After fabrication, parts are sorted by maximum processor core frequency as shown in the Section “Clock AC Specifications,” on page 13, and tested for conformance to the AC specifications for that frequency. Parts are sold by maximum processor core frequency, subject to the specified application conditions; see Section “Ordering Information,” on page 46. Unless otherwise noted, all timings apply for all I/O supply voltages.

Clock AC Specifications

The following table provides the clock AC timing specifications as defined in Figure 2.

Clock AC Timing Specifications

See Table “Recommended Operating Conditions,” on page 9, for operating conditions.

Num	Characteristic	Fmax = 300-375MHz		Fmax \geq 400MHz		Unit	Notes
		Min	Max	Min	Max		
	Processor frequency	TBD	As specified by part number	250	As specified by part number	MHz	6
	SYSClk frequency	25	100	31	100	MHz	1
1	SYSClk cycle time	10	40	10	32	ns	
2,3	SYSClk rise and fall time	–	1.0	–	1.0	ns	2,3
4	SYSClk duty cycle measured at Vm	40	60	40	60	%	3
	SYSClk jitter	–	± 150	–	± 150	ps	4,3
	Internal PLL relock time	–	100	–	100	μs	5

Note:

- Caution: The SYSClk frequency and the PLL_CFG[0:3] settings must be chosen such that the resulting SYSClk (bus) frequency, and CPU (core) frequency do not exceed their respective maximum or minimum operating frequencies. Refer to the PLL_CFG[0:3] signal description in Section “PLL Configuration,” on page 36 for valid PLL_CFG[0:3] settings. Bus operation above 100 MHz is possible, but requires careful timing analysis. Contact IBM for details.
- Rise and fall times for the SYSClk input are measured from 0.5 to 1.5V.
- Timing is guaranteed by design and characterization, and is not tested.
- The total input jitter (short term and long term combined) must be under $\pm 150\text{ps}$. Contact IBM for operation with Spread Spectrum clocks or clocks with more than $\pm 150\text{ps}$ total jitter.
- Relock timing is guaranteed by design and characterization, and is not tested. PLL-relock time is the maximum amount of time required for PLL lock after a stable V_{DD} and SYSClk are reached during the power-on reset sequence. This specification also applies when the PLL has been disabled and subsequently re-enabled during sleep mode. Also note that HRESET must be held asserted for a minimum of 255 bus clocks after the PLL-relock time during the power-on reset sequence.
- Under certain conditions, operation at core frequencies below those stated is possible. Contact IBM for details.

Figure 2. SYSClk Input Timing Diagram

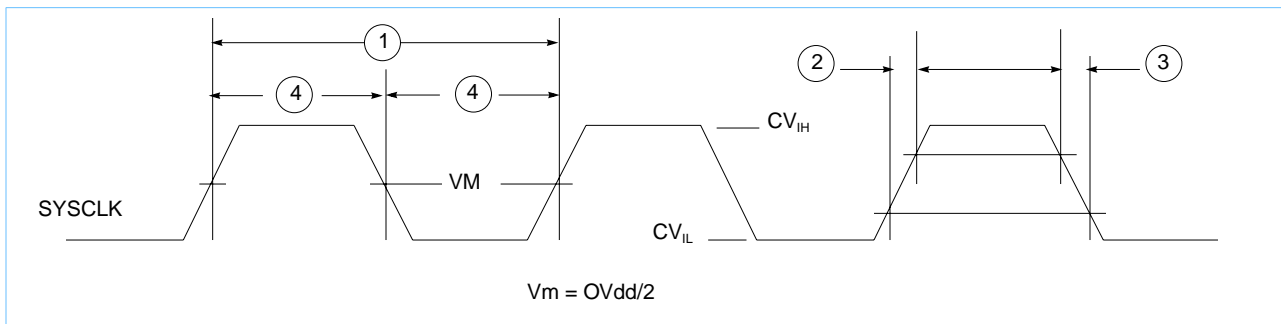

60x Bus Input AC Specifications

The following table provides the 60X bus input AC timing specifications for the 750 as defined in Figure 3 and Figure 4. Input timing specifications for the L2 bus are provided in Section, "L2 Bus Input AC Specifications" on page 20.

60X Bus Input Timing Specifications¹

See Table "Recommended Operating Conditions," on page 9, for operating conditions.

Num	Characteristic	All Frequencies		Unit	Notes
		Minimum	Maximum		
10a	Address/Data/Transfer Attribute Inputs Valid to SYSCLK (Input Setup)	2.5	—	ns	2
10b	All Other Inputs Valid to SYSCLK (Input Setup)	2.5	—	ns	3
10c	Mode Select Input Setup to HRESET (DRTRY, TLBISYNC)	8	—	t_{sysclk}	4,5,6,7
11a	SYSCLK to Address/Data/Transfer Attribute Inputs Invalid (Input Hold)	0.6	—	ns	2
11b	SYSCLK to All Other Inputs Invalid (Input Hold)	0.6	—	ns	3
11c	HRESET to mode select input hold (DRTRY, TLBISYNC)	0	—	ns	4,6,7

Note:

- Input specifications are measured from the Vm of the signal in question to the Vm of the rising edge of the input SYSCLK. Input and output timings are measured at the pin (see Figure 3).
- Address/Data Transfer Attribute inputs are composed of the following—A[0:31], AP[0:3], TT[0:4], TBST, TSIZ[0:2], GBL, DH[0:31], DL[0:31], DP[0:7].
- All other signal inputs are composed of the following—TS, ABB, DBB, ARTRY, BG, AACK, DBG, DBWO, TA, DRTRY, TEA, DBDIS, TBEN, QACK, TLBISYNC.
- The setup and hold time is with respect to the rising edge of HRESET (see Figure 4).
- t_{SYSCLK} is the period of the external clock (SYSCLK) in nanoseconds (ns). The numbers given in the table must be multiplied by the period of SYSCLK to compute the actual time duration (in ns) of the parameter in question.
- These values are guaranteed by design, and are not tested.
- This specification is for configuration mode select only. Also note that the HRESET must be held asserted for a **minimum of 255 bus clocks** after the PLL re-lock time during the power-on reset sequence.

Figure 3. Input Timing Diagram

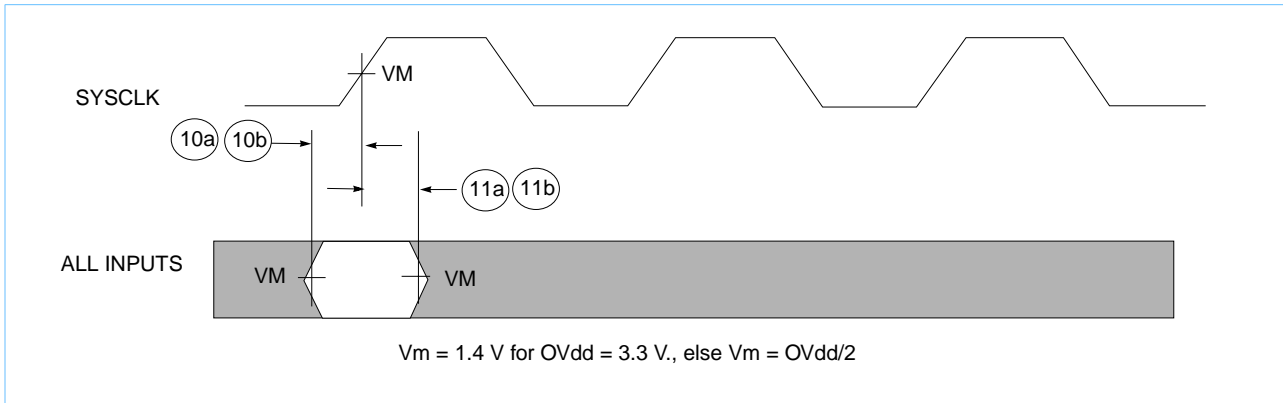
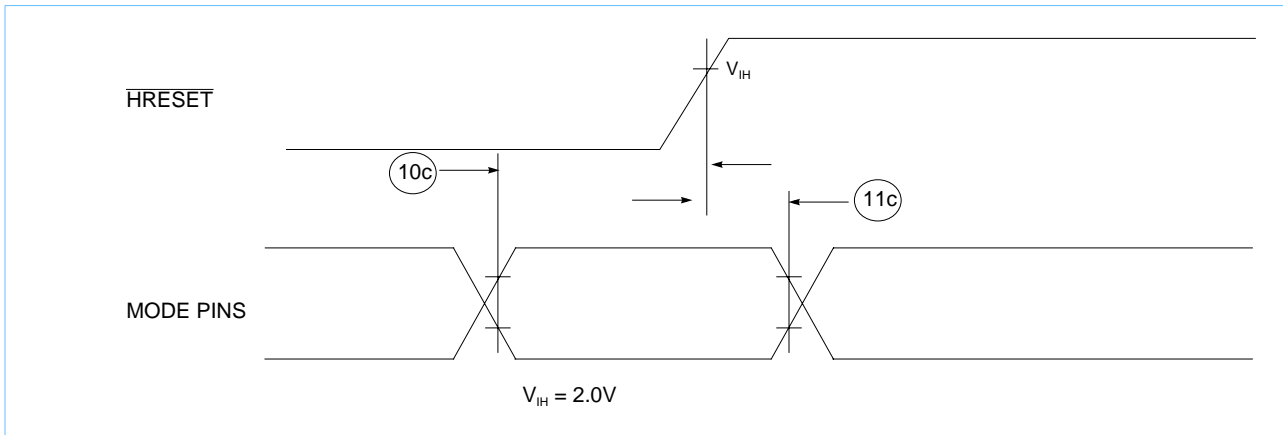

Figure 4. Mode Select Input Timing Diagram



60x Bus Output AC Specifications

The following table provides the 60x bus output AC timing specifications for the 750 as defined in Figure 5. Output timing specification for the L2 bus are provided in the Section "L2 Bus Output AC Specifications," on page 21.

60X Bus Output AC Timing Specifications for the 750¹

See Table "Recommended Operating Conditions," on page 9 for operating conditions, $C_L = 50\text{pF}^2$

Num	Characteristic	All Frequencies		Unit	Notes
		Minimum	Maximum		
12	SYCLK to Output Driven (Output Enable Time)	0.5		ns	8
13	SYCLK to Output Valid ($\overline{\text{TS}}$, $\overline{\text{ABB}}$, $\overline{\text{ARTRY}}$, $\overline{\text{DBB}}$, and $\overline{\text{TBST}}$)	–	4.5	ns	5
14	SYCLK to all other Output Valid (all except $\overline{\text{TS}}$, $\overline{\text{ABB}}$, $\overline{\text{ARTRY}}$, $\overline{\text{DBB}}$, and $\overline{\text{TBST}}$)	–	5.0	ns	5
15	SYCLK to Output Invalid (Output Hold)	1.0		ns	3, 8, 9
16	SYCLK to Output High Impedance (all signals except $\overline{\text{ABB}}$, $\overline{\text{ARTRY}}$, and $\overline{\text{DBB}}$)	–	6.0	ns	8
17	SYCLK to $\overline{\text{ABB}}$ and $\overline{\text{DBB}}$ high impedance after precharge	–	1.0	t_{SYCLK}	4, 6, 8
18	SYCLK to $\overline{\text{ARTRY}}$ high impedance before precharge	–	5.5	ns	8
19	SYCLK to $\overline{\text{ARTRY}}$ precharge enable	$0.2 \times t_{\text{SYCLK}} + 1.0$		ns	3, 4, 7
20	Maximum delay to $\overline{\text{ARTRY}}$ precharge		1	t_{SYCLK}	4, 7
21	SYCLK to $\overline{\text{ARTRY}}$ high impedance after precharge		2	t_{SYCLK}	4, 7, 8

Note:

1. All output specifications are measured from V_m of the rising edge of SYCLK to V_m of the signal in question. Both input and output timings are measured at the pin.
2. All maximum timing specifications assume $C_L = 50\text{pF}$.
3. This minimum parameter assumes $C_L = 0\text{pF}$.
4. t_{SYCLK} is the period of the external bus clock (SYCLK) in nanoseconds (ns). The numbers given in the table must be multiplied by the period of SYCLK to compute the actual time duration of the parameter in question.
5. This footnote has been deleted.
6. Nominal precharge width for $\overline{\text{ABB}}$ and $\overline{\text{DBB}}$ is $0.5 t_{\text{SYCLK}}$.
7. Nominal precharge width for $\overline{\text{ARTRY}}$ is $1.0 t_{\text{SYCLK}}$.
8. Guaranteed by design and characterization, and not tested.
9. Connecting L2_TSTCLK to GND no longer provides additional Output Hold. For new designs, L2_TSTCLK should be pulled up to OVdd, but it can be left connected to GND in Legacy systems.

Figure 5. Output Timing Diagram

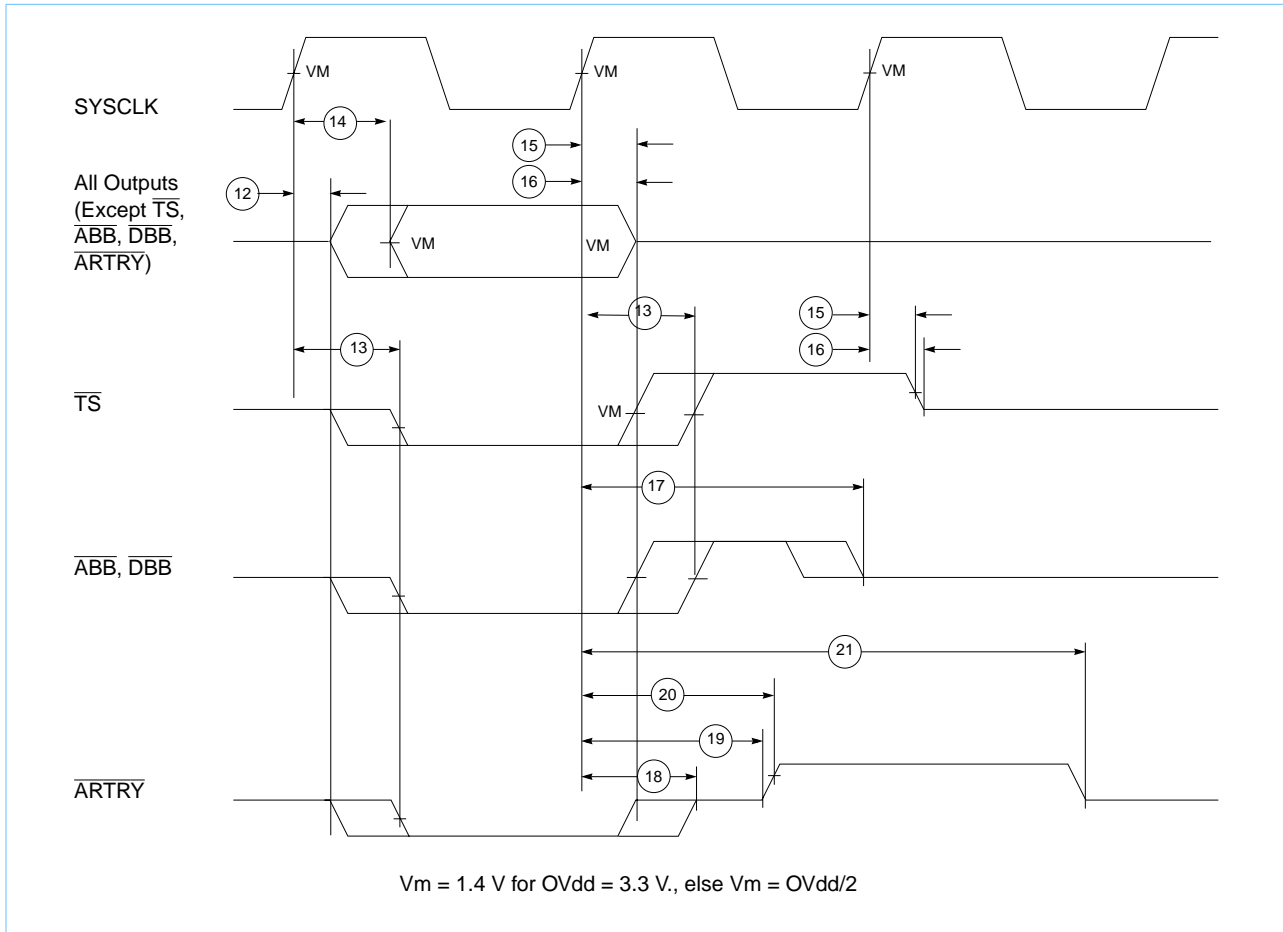

L2 Clock AC Specifications

The following table provides the L2CLK output AC timing specifications for the 750 as defined in Figure 6.

L2CLK Output AC Timing Specifications

See Table "Recommended Operating Conditions," on page 9, for operating conditions.

Num	Characteristic	Min	Max	Unit	Notes
	L2CLK frequency	80	250	MHz	1, 5
22	L2CLK cycle time	4.0	12.5	ns	
23	L2CLK duty cycle	50		%	2
	Internal DLL-relock time	640	—	L2CLK	4
	L2CLK jitter		± 150	ps	3, 6
	L2CLK skew		0	ps	7

Note:

1. L2CLK outputs are L2CLKOUTA, L2CLKOUTB and L2SYNC_OUT pins. The internal design supports higher L2CLK frequencies. Consult IBM PowerPC Application Engineering (ppcsupp@us.ibm.com) before operating the L2 SRAMs above 250 MHz. The L2CLK frequency to core frequency settings must be chosen such that the resulting L2CLK frequency and core frequency do not exceed their respective maximum or minimum operating frequencies. L2CLKOUTA and L2CLKOUTB must have equal loading.
2. The nominal duty cycle of the L2CLK is 50% measured at midpoint voltage.
3. The major component of L2CLK jitter is passed through from SYSCLK. While SYSCLK jitter is less than ± 150 ps, L2CLK jitter is also less than ± 150 ps. SYSCLK jitter in excess of ± 150 ps causes L2CLK jitter to exceed ± 150 ps.
4. The DLL re-lock time is specified in terms of L2CLKs. The number in the table must be multiplied by the period of L2CLK to compute the actual time duration in nanoseconds. Re-lock timing is guaranteed by design and characterization, and is not tested.
5. The L2CR [L2SL] bit should be set for L2CLK frequencies less than 110MHz.
6. Guaranteed by design and characterization, not tested.
7. Skew between the L2 output clocks is included in the other timing specs.

Figure 6. L2CLK_OUT Output Timing Diagram

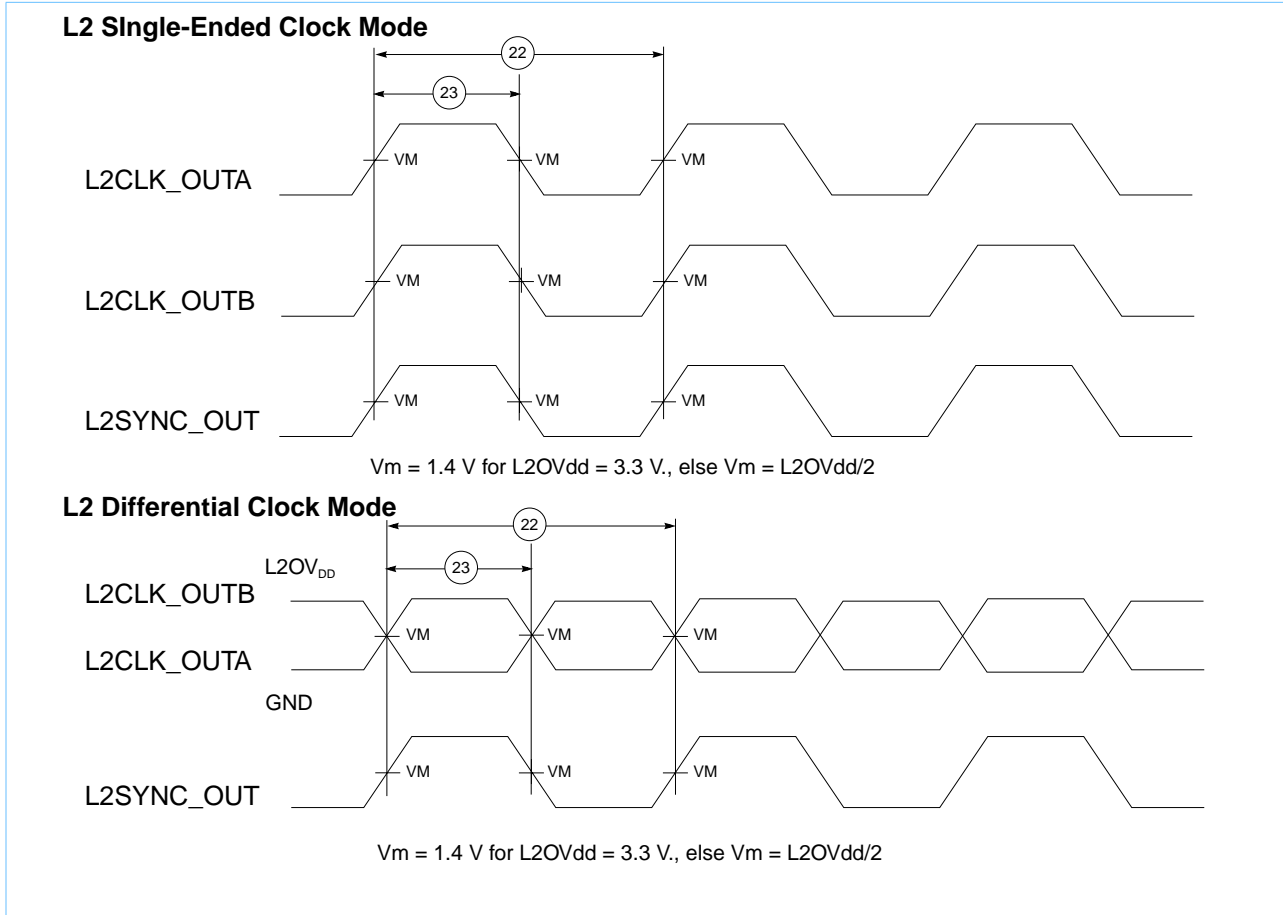

L2 Bus Input AC Specifications

Some specifications are shown in the following table as a Function of Maximum Core Frequency (Fmax). These specifications refer to the effective Fmax of the part after derating for application conditions. For example, a nominal 450 MHz part running at application conditions that derate its Fmax to 400 MHz will meet or exceed the specifications shown for Fmax = 400 MHz.

L2 Bus Input Interface AC Timing Specifications

See Table "Recommended Operating Conditions," on page 9, for operating conditions.

Num	Characteristic	Min	Max	Unit	Notes
29,30	L2SYNC_IN rise and fall time	—	1.0	ns	2,3
24	Data and parity input setup to L2SYNC_IN, Fmax up through 375 MHz.	1.5	—	ns	1
24	Data and parity input setup to L2SYNC_IN, Fmax = 400 MHz.	1.4	—	ns	1
24	Data and parity input setup to L2SYNC_IN, Fmax = 433 and 450 MHz.	1.1	—	ns	1
24	Data and parity input setup to L2SYNC_IN, Fmax = 466 and 500 MHz.	1.0	—	ns	1
25	L2SYNC_IN to data and parity input hold	0.5	—	ns	1

Note:

1. All input specifications are measured from the Vm of the signal in question to the Vm of the rising edge of the input L2SYNC_IN. Input timings are measured at the pins (see Figure 7).
2. Rise and fall times for the L2SYNC_IN input are measured from 0.5 to 1.5V.
3. Guaranteed by design and characterization, and not tested.

Figure 7. L2 Bus Input Timing Diagrams

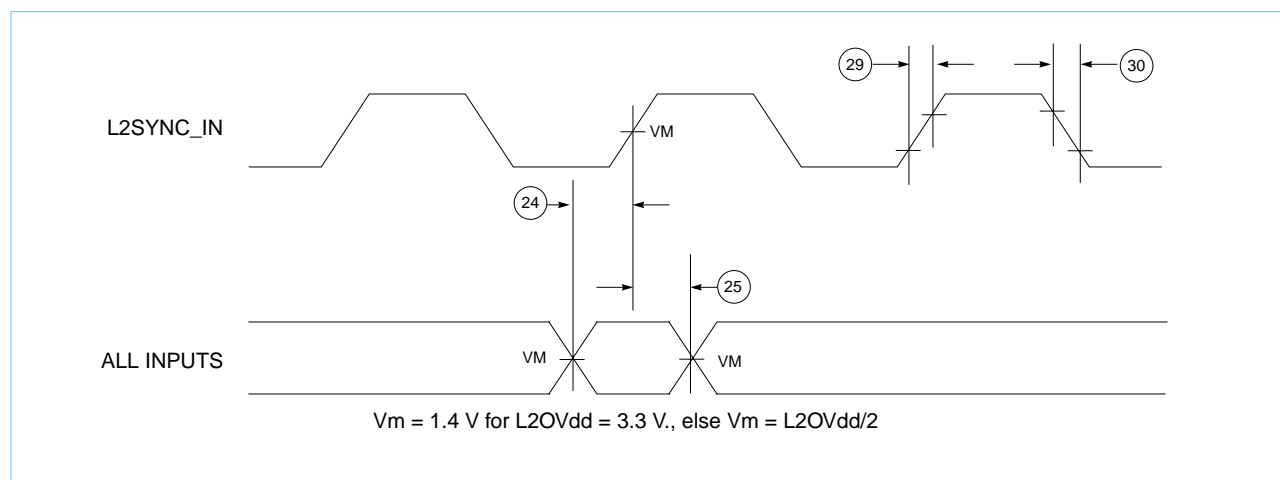

L2 Bus Output AC Specifications

L2 Bus Output Interface AC Timing Specifications¹

See Table "Recommended Operating Conditions," on page 9 for operating conditions, $C_L = 20\text{pF}^3$

Num	Characteristic	L2CR[14:15] is equivalent to:								Unit	Notes
		00 ²		01		10		11			
		Min	Max	Min	Max	Min	Max	Min	Max		
26	L2SYNC_IN to output valid, F_{max}^7 up through 375 MHz.	—	3.2	—	3.7	—	Rsv ⁵	—	Rsv ⁵	ns	
26	L2SYNC_IN to output valid, $F_{\text{max}} = 400$ MHz.	—	3.0	—	3.5	—	Rsv ⁵	—	Rsv ⁵	ns	
26	L2SYNC_IN to output valid, $F_{\text{max}} = 433$ and 450 MHz.	—	2.6	—	3.1	—	Rsv ⁵	—	Rsv ⁵	ns	
26	L2SYNC_IN to output valid, $F_{\text{max}} = 466$ and 500 MHz.	—	2.4	—	2.9	—	Rsv ⁵	—	Rsv ⁵	ns	
27	L2SYNC_IN to output hold	0.5	—	1.0	—	Rsv ⁵	—	Rsv ⁵	—	ns	4,6
28	L2SYNC_IN to high impedance	—	3.5	—	4.0	—	Rsv ⁵	—	Rsv ⁵	ns	6

Note:

1. All outputs are measured from the V_m of the rising edge of L2SYNC_IN to the V_m of the signal in question. The output timings are measured at the pins (see Figure 8).
2. The outputs are valid for both single-ended and differential L2CLK modes. For flow-through and pipelined reg-reg synchronous burst SRAMs, L2CR[14:15] = 00 is recommended. For pipelined late-write synchronous burst SRAMs, L2CR[14:15] = 01 is recommended.
3. All maximum timing specifications assume $C_L = 20\text{pF}$.
4. This measurement assumes $C_L = 5\text{pF}$.
5. Reserved for future use.
6. Guaranteed by design and characterization, and not tested.
7. Specifications are shown as a Function of Maximum Core Frequency (F_{max}). They refer to the effective F_{max} of the part after derating for application conditions. For example, a nominal 450 MHz part running at application conditions that derate its F_{max} to 400 MHz will meet or exceed the specifications shown for $F_{\text{max}} = 400$ MHz.

Figure 8. L2 Bus Output Timing Diagrams

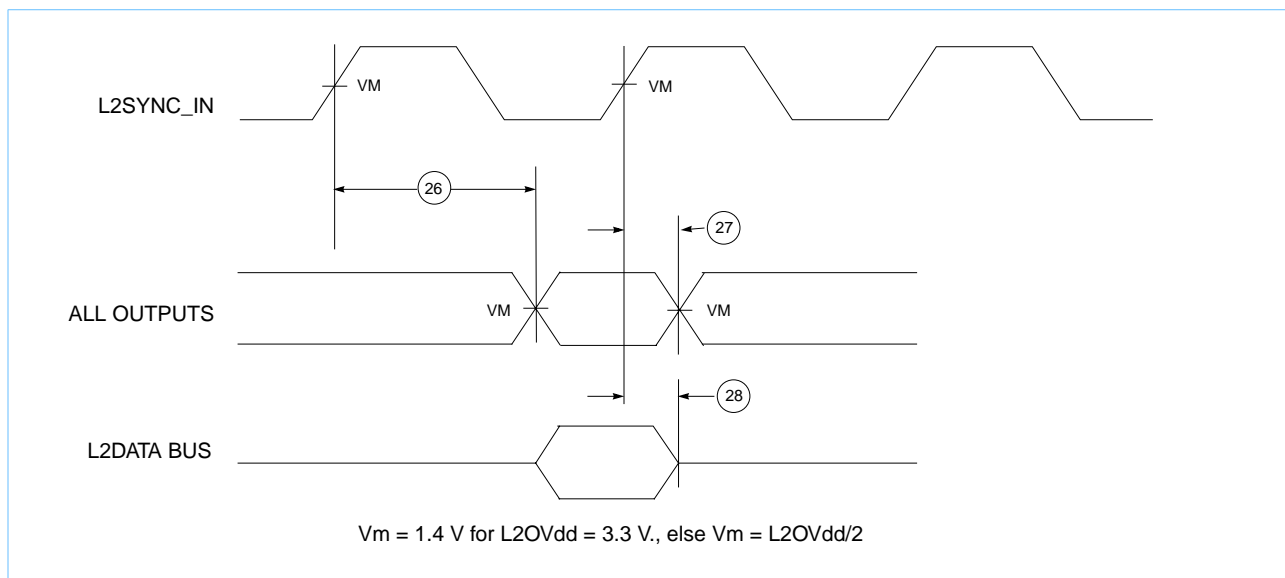

IEEE 1149.1 AC Timing Specifications

The table below provides the IEEE 1149.1 (JTAG) AC timing specifications as defined in Figure 9, Figure 10, Figure 11, and Figure 12. The five JTAG signals are; TDI, TDO, TMS, TCK, and $\overline{\text{TRST}}$.

JTAG AC Timing Specifications (Independent of SYSCLK)

See Table "Recommended Operating Conditions," on page 9 for operating conditions, $C_L = 50\text{pF}$.

Num	Characteristic	Min	Max	Unit	Notes
	TCK frequency of operation	0	25	MHz	
1	TCK cycle time	40	—	ns	
2	TCK clock pulse width measured at 1.4V	15	—	ns	
3	TCK rise and fall times	0	2	ns	4
4	spec obsolete, intentionally omitted				
5	$\overline{\text{TRST}}$ assert time	25	—	ns	1
6	Boundary-scan input data setup time	4	—	ns	2
7	Boundary-scan input data hold time	16	—	ns	2
8	TCK to output data valid	4	20	ns	3, 5
9	TCK to output high impedance	3	19	ns	3, 4
10	TMS, TDI data setup time	0	—	ns	
11	TMS, TDI data hold time	16	—	ns	
12	TCK to TDO data valid	2.5	12	ns	5
13	TCK to TDO high impedance	3	9	ns	4

Note:

1. $\overline{\text{TRST}}$ is an asynchronous level sensitive signal. Guaranteed by design.
2. Non-JTAG signal input timing with respect to TCK.
3. Non-JTAG signal output timing with respect to TCK.
4. Guaranteed by characterization and not tested.
5. Minimum spec guaranteed by characterization and not tested.

Figure 9. JTAG Clock Input Timing Diagram

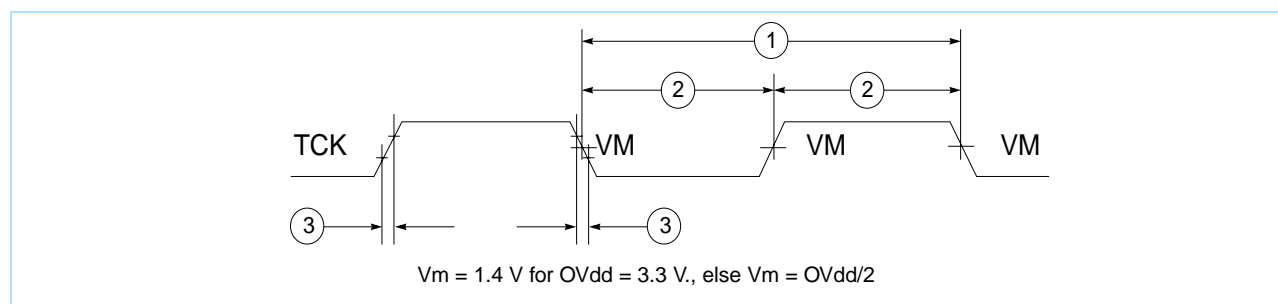

Figure 10. $\overline{\text{TRST}}$ Timing Diagram

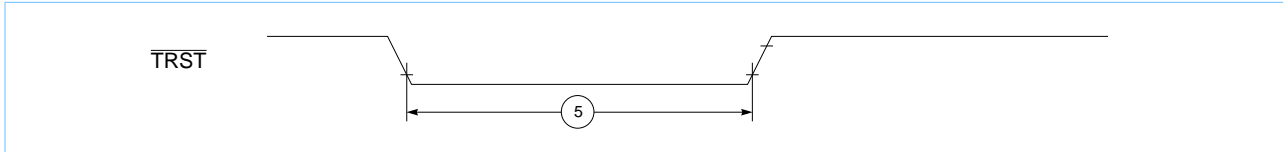

Figure 11. Boundary-Scan Timing Diagram

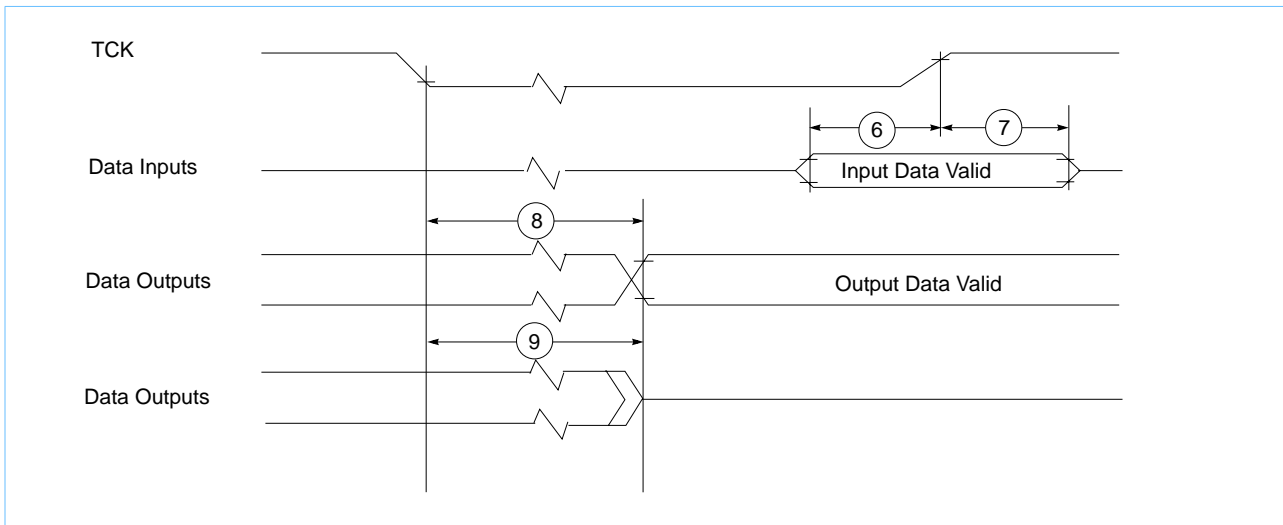
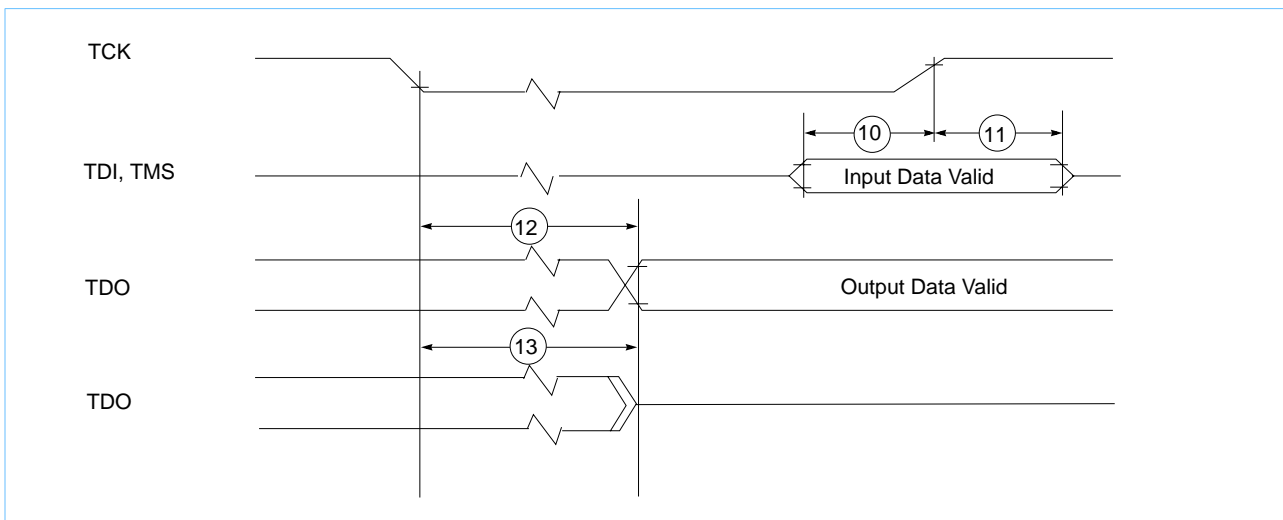

Figure 12. Test Access Port Timing Diagram



PowerPC 740 Microprocessor Pin Assignments

The following sections contain the pinout diagrams for the PowerPC 740, a 255 pin ceramic ball grid array (BGA) package.

Figure 13 (in part A) shows the pinout of the PPC 740, a 255 pin Ceramic Ball Grid Array (CBGA) package as viewed from the top surface. Part B shows the side profile.

Figure 13. Pinout of the PowerPC 740 BGA Package as Viewed from the Top Surface

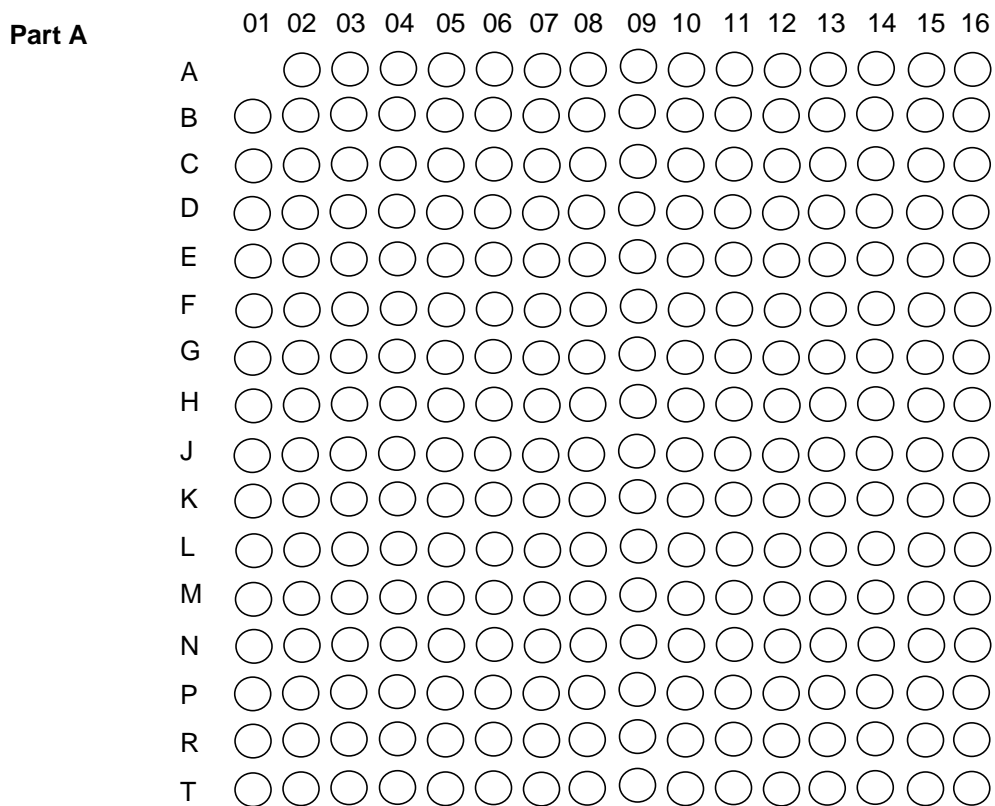

Not to Scale

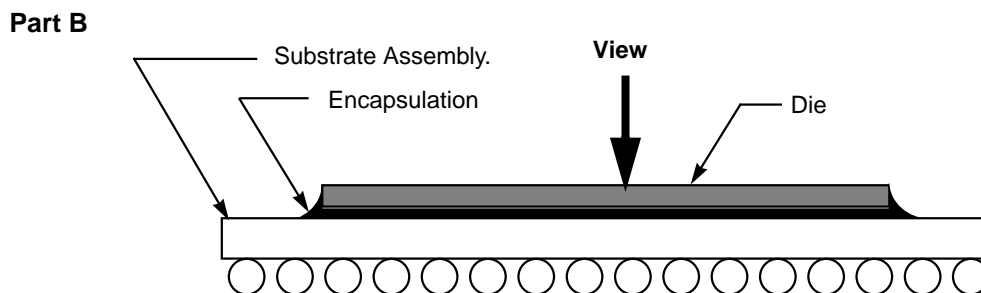



PowerPC 740 Microprocessor Pinout Listings

Pinout Listing for the PowerPC 740 255 CBGA Package

Signal Name	Pin Number	Active	I/O
A[0:31]	C16, E04, D13, F02, D14, G01, D15, E02, D16, D04, E13, GO2, E15, H01, E16, H02, F13, J01, F14, J02, F15, H03, F16, F04, G13, K01, G15, K02, H16, M01, J15, P01	High	I/O
$\overline{\text{AACK}}$	L02	Low	Input
$\overline{\text{ABB}}$	K04	Low	I/O
AP[0:3]	C01, B04, B03, B02	High	I/O
$\overline{\text{ARTRY}}$	J04	Low	I/O
AVDD	A10	—	—
$\overline{\text{BG}}$	L01	Low	Input
BR	B06	Low	Output
BVSEL ¹	H04		Input
$\overline{\text{CI}}$	E01	Low	Output
$\overline{\text{CKSTP_IN}}$	D08	Low	Input
$\overline{\text{CKSTP_OUT}}$	A06	Low	Output
CLK_OUT	D07	—	Output
$\overline{\text{DBB}}$	J14	Low	I/O
$\overline{\text{DBG}}$	N01	Low	Input
$\overline{\text{DBDIS}}$	H15	Low	Input
$\overline{\text{DBWO}}$	G04	Low	Input
DH[0:31]	P14, T16, R15, T15, R13, R12, P11, N11, R11, T12, T11, R10, P09, N09, T10, R09, T09, P08, N08, R08, T08, N07, R07, T07, P06, N06, R06, T06, R05, N05, T05, T04	High	I/O
DL[0:31]	K13, K15, K16, L16, L15, L13, L14, M16, M15, M13, N16, N15, N13, N14, P16, P15, R16, R14, T14, N10, P13, N12, T13, P03, N03, N04, R03, T01, T02, P04, T03, R04	High	I/O
DP[0:7]	M02, L03, N02, L04, R01, P02, M04, R02	High	I/O
$\overline{\text{DRTRY}}$	G16	Low	Input
$\overline{\text{GBL}}$	F01	Low	I/O
GND	C05, C12, E03, E06, E08, E09, E11, E14, F05, F07, F10, F12, G06, G08, G09, G11, H05, H07, H10, H12, J05, J07, J10, J12, K06, K08, K09, K11, L05, L07, L10, L12, M03, M06, M08, M09, M11, M14, P05, P12	—	—

Pinout Listing for the PowerPC 740 255 CBGA Package (cont.)

Signal Name	Pin Number	Active	I/O
HRESET	A07	Low	Input
INT	B15	Low	Input
L1_TSTCLK ²	D11	High	Input
L2_TSTCLK ²	D12	High	Input
LSSD_MODE ²	B10	Low	Input
MCP	C13	Low	Input
NC (No-Connect)	B07, B08, C03, C06, C08, D05, D06, J16, A04, A05, A02, A03, B01, B05	—	—
OVDD	C07, E05, E07, E10, E12, G03, G05, G12, G14, K03, K05, K12, K14, M05, M07, M10, M12, P07, P10	—	—
PLL_CFG[0:3]	A08, B09, A09, D09	High	Input
QACK	D03	Low	Input
QREQ	J03	Low	Output
RSRV	D01	Low	Output
SMI	A16	Low	Input
SRESET	B14	Low	Input
SYSCLK	C09	—	Input
TA	H14	Low	Input
TBEN	C02	High	Input
TBST	A14	Low	I/O
TCK	C11	High	Input
TDI	A11	High	Input
TDO	A12	High	Output
TEA	H13	Low	Input
TLBISYNC	C04	Low	Input
TMS	B11	High	Input
TRST	C10	Low	Input
TS	J13	Low	I/O
TSIZ[0:2]	A13, D10, B12,	High	Output
TT[0:4]	B13, A15, B16, C14, C15	High	I/O
WT	D02	Low	Output



Pinout Listing for the PowerPC 740 255 CBGA Package (cont.)

Signal Name	Pin Number	Active	I/O
VDD ³	F06, F08, F09, F11, G07, G10, H06, H08, H09, H11, J06, J08, J09, J11, K07, K10, L06, L08, L09, L11	—	—
VOLTDET ⁴	F03	Low	Output

Note:

1. BVSEL Function

Unconnected or Pulled to OVdd (3.3V nominal)	OVdd = 3.3 V nominal
Connected to $\overline{\text{HRESET}}$	OVdd = 2.5 V nominal
Connected to GND	OVdd = 1.8 V nominal

If BVSEL is connected to GND with a series resistor, the resistor value must be 10 Ω or less.

2. These are test signals for factory use only and must be pulled up to OVdd for normal operation.
3. OVdd inputs supply power to the I/O drivers and Vdd inputs supply power to the processor core.
4. Internally tied to GND in the 255 CBGA package. This is NOT a supply pin.

PowerPC 740 Package

Package Type	Ceramic Ball Grid Array (CBGA)
Package outline	21 x 21mm
Interconnects	255 (16 x 16 ball array - 1)
Pitch	1.27mm (50mil)
Minimum module height	2.45mm
Maximum module height	3.00mm
Ball diameter	0.89mm (35mil)

Mechanical Dimensions of the PowerPC 740 255 CBGA Package

Figure 14. Mechanical Dimensions and Bottom Surface Nomenclature of the 255 CBGA Package

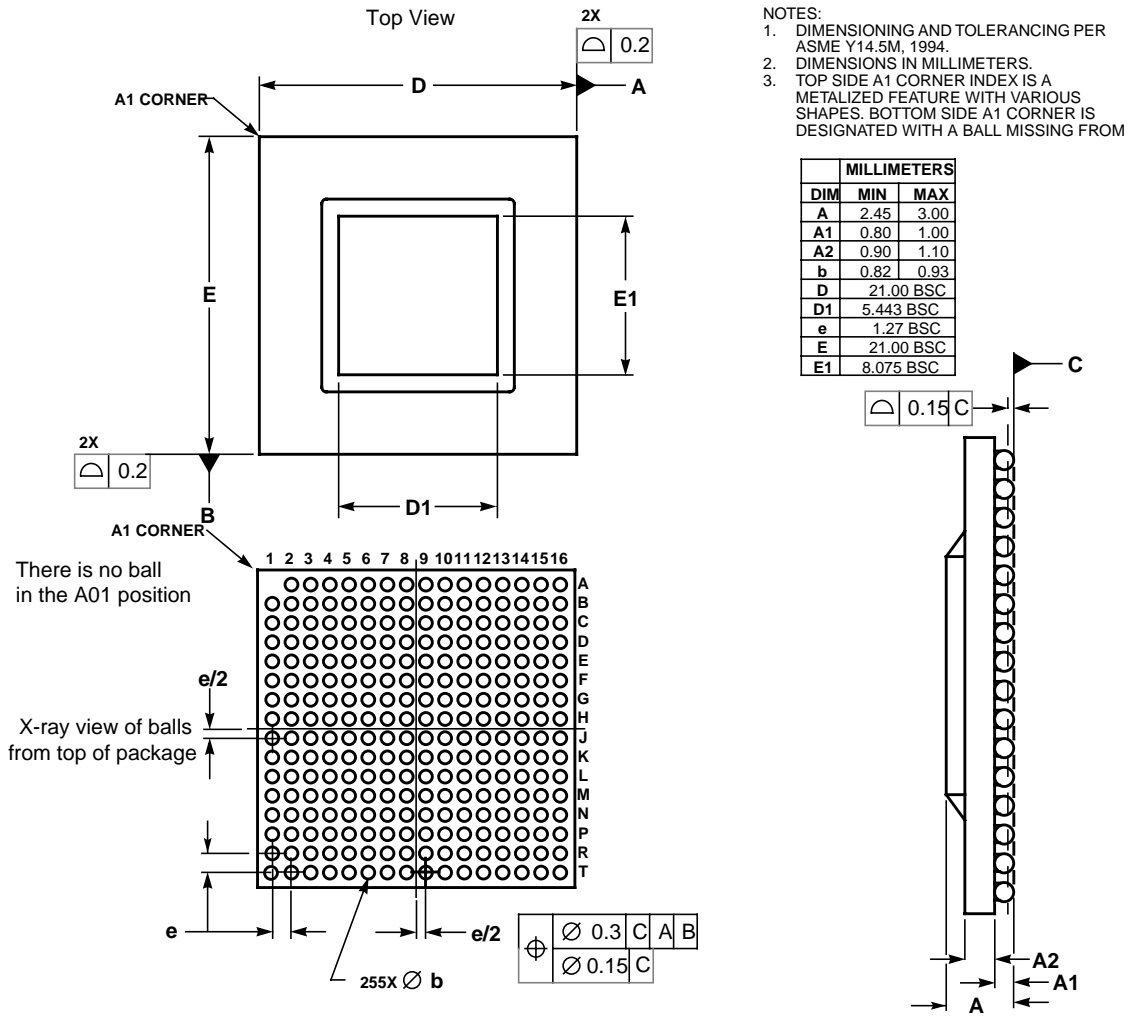

PowerPC 750 Microprocessor Pin Assignments

The following sections contain the pinout diagrams for the PowerPC 750 ceramic ball grid array 360 CBGA packages.

Figure 15 (in part A) shows the pinout of the 360 CBGA package as viewed from the top surface. Part B shows the side profile of the 360 CBGA package to indicate the direction of the top surface view.

Figure 15. Pinout of the 750 360 CBGA Package as Viewed from the Top Surface

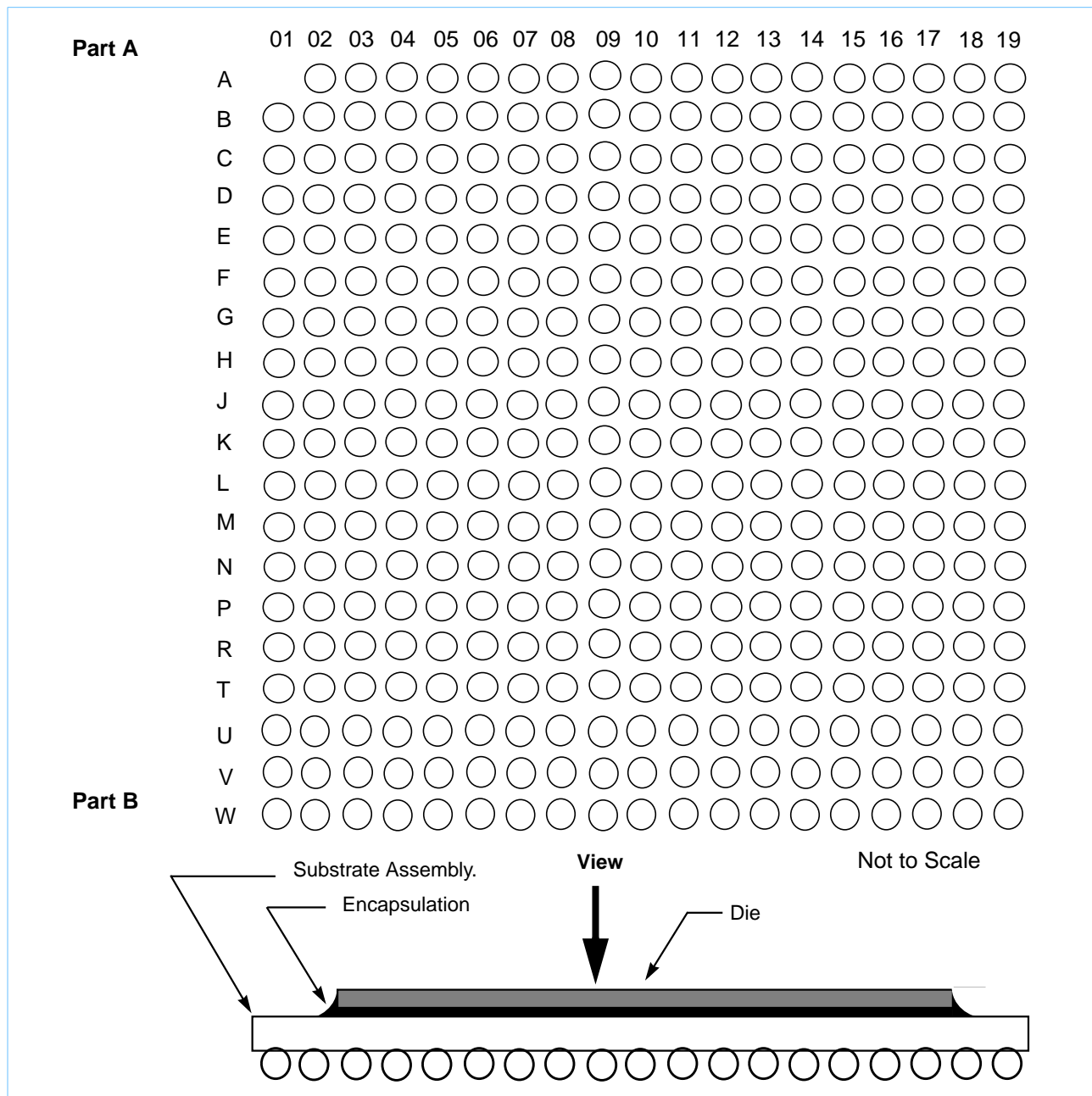



Pinout Listing for the PowerPC 750 360 CBGA package

Signal Name	Pin Number	Active	I/O
A[0:31]	A13, D2, H11, C1, B13, F2, C13, E5, D13, G7, F12, G3, G6, H2, E2, L3, G5, L4, G4, J4, H7, E1, G2, F3, J7, M3, H3, J2, J6, K3, K2, L2	High	I/O
AACK	N3	Low	Input
ABB	L7	Low	I/O
AP[0:3]	C4, C5, C6, C7	High	I/O
ARTRY	L6	Low	I/O
AVDD ¹	A8	—	—
BG	H1	Low	Input
BR	E7	Low	Output
BVSEL ²	W01 ²	—	Input
CKSTP_OUT	D7	Low	Output
CI	C2	Low	Output
CKSTP_IN	B8	Low	Input
CLKOUT	E3	—	Output
DBB	K5	Low	I/O
DBDIS	G1	Low	Input
DBG	K1	Low	Input
DBW0	D1	Low	Input
DH[0:31]	W12, W11, V11, T9, W10, U9, U10, M11, M9, P8, W7, P9, W9, R10, W6, V7, V6, U8, V9, T7, U7, R7, U6, W5, U5, W4, P7, V5, V4, W3, U4, R5	High	I/O
DL[0:31]	M6, P3, N4, N5, R3, M7, T2, N6, U2, N7, P11, V13, U12, P12, T13, W13, U13, V10, W8, T11, U11, V12, V8, T1, P1, V1, U1, N1, R2, V3, U3, W2	High	I/O
DP[0:7]	L1, P2, M2, V2, M1, N2, T3, R1	High	I/O
DRTRY	H6	Low	Input
GBL	B1	Low	I/O
GND	D10, D14, D16, D4, D6, E12, E8, F4, F6, F10, F14, F16, G9, G11, H5, H8, H10, H12, H15, J9, J11, K4, K6, K8, K10, K12, K14, K16, L9, L11, M5, M8, M10, M12, M15, N9, N11, P4, P6, P10, P14, P16, R8, R12, T4, T6, T10, T14, T16	—	—
HRESET	B6	Low	Input
INT	C11	Low	Input
L1_TSTCLK ³	F8	High	Input
L2ADDR[0:16]	L17, L18, L19, M19, K18, K17, K15, J19, J18, J17, J16, H18, H17, J14, J13, H19, G18	High	Output
L2AVDD	L13	—	—
L2CE	P17	Low	Output
L2CLKOUTA	N15	—	Output



PowerPC 740 and PowerPC 750 Microprocessor
CMOS 0.20 μ m Copper Technology, PID-8p, PPC740L and PPC750L, dd3.2

Pinout Listing for the PowerPC 750 360 CBGA package (cont.)

Signal Name	Pin Number	Active	I/O
L2CLKOUTB	L16	—	Output
L2DATA[0:63]	U14, R13, W14, W15, V15, U15, W16, V16, W17, V17, U17, W18, V18, U18, V19, U19, T18, T17, R19, R18, R17, R15, P19, P18, P13, N14, N13, N19, N17, M17, M13, M18, H13, G19, G16, G15, G14, G13, F19, F18, F13, E19, E18, E17, E15, D19, D18, D17, C18, C17, B19, B18, B17, A18, A17, A16, B16, C16, A14, A15, C15, B14, C14, E13	High	I/O
L2DP[0:7]	V14, U16, T19, N18, H14, F17, C19, B15	High	I/O
L2OVDD	D15, E14, E16, H16, J15, L15, M16, P15, R14, R16, T15, F15	—	—
L2SYNC_IN	L14	—	Input
L2SYNC_OUT	M14	—	Output
L2_TSTCLK ³	F7	High	Input
L2VSEL	A19 ²	—	Input
$\overline{\text{L2WE}}$	N16	Low	Output
L2ZZ	G17	High	Output
$\overline{\text{LSSD_MODE}}^3$	F9	Low	Input
$\overline{\text{MCP}}$	B11	Low	Input
NC (No-Connect)	B3, B4, B5, W19, K9, K11 ⁴ , K19 ⁴	—	—
OVDD ²	D5, D8, D12, E4, E6, E9, E11, F5, H4, J5, L5, M4, P5, R4, R6, R9, R11, T5, T8, T12	—	—
PLL_CFG[0:3]	A4, A5, A6, A7	High	Input
$\overline{\text{QACK}}$	B2	Low	Input
$\overline{\text{QREQ}}$	J3	Low	Output
$\overline{\text{RSRV}}$	D3	Low	Output
$\overline{\text{SMI}}$	A12	Low	Input
$\overline{\text{SRESET}}$	E10	Low	Input
SYSCLK	H9	—	Input
$\overline{\text{TA}}$	F1	Low	Input
TBEN	A2	High	Input
$\overline{\text{TBST}}$	A11	Low	I/O
TCK	B10	High	Input
TDI	B7	High	Input
TDO	D9	High	Output
$\overline{\text{TEA}}$	J1	Low	Input
$\overline{\text{TLBISYNC}}$	A3	Low	Input
TMS	C8	High	Input
$\overline{\text{TRST}}$	A10	Low	Input
$\overline{\text{TS}}$	K7	Low	I/O



Pinout Listing for the PowerPC 750 360 CBGA package (cont.)

Signal Name	Pin Number	Active	I/O
TSIZ[0:2]	A9, B9, C9	High	Output
TT[0:4]	C10, D11, B12, C12, F11	High	I/O
$\overline{\text{WT}}$	C3	Low	Output
VDD ⁵	G8, G10, G12, J8, J10, J12, L8, L10, L12, N8, N10, N12	—	—
VOLTDET ⁶	K13	High	Output

Note:

1. For dd3.x on the 750 only, AVdd is no longer connected to the BGA pin. AVdd is filtered on the module from Vdd. The 740 dd3.2 does require AVdd.
2. BVSEL and L2VSEL Function

Unconnected	L2OVdd = 3.3 V nominal
Connected to $\overline{\text{HRESET}}$	OVdd = 2.5 V nominal
Connected to GND	OVdd = 1.8 V nominal

If BVSEL or L2VSEL is connected to GND with a series resistor, the resistor value must be 10 Ω or less.

3. These are test signals for factory use only and must be pulled up to OVdd for normal operation. During normal operation, L2_TSTCLK can be connected to GND if required.
4. These pins are reserved for potential future use as additional L2 address pins.
5. OVdd inputs supply power to the I/O drivers, and Vdd inputs supply power to the processor core.
6. Internally tied to L2OV_{DD} in the 750 360 CBGA package. This is NOT a supply pin.

PowerPC 750 Package

Package Type	Ceramic Ball Grid Array (CBGA)
Package outline	25 x 25mm
Interconnects	360 (19 x 19 ball array - 1)
Pitch	1.27mm (50mil)
Minimum module height	2.65mm
Maximum module height	3.20mm
Ball diameter	0.89mm (35mil)

Mechanical Dimensions of the PowerPC 750 360 CBGA Package

Figure 16. Mechanical Dimensions and Bottom Surface Nomenclature of the 360 CBGA Package

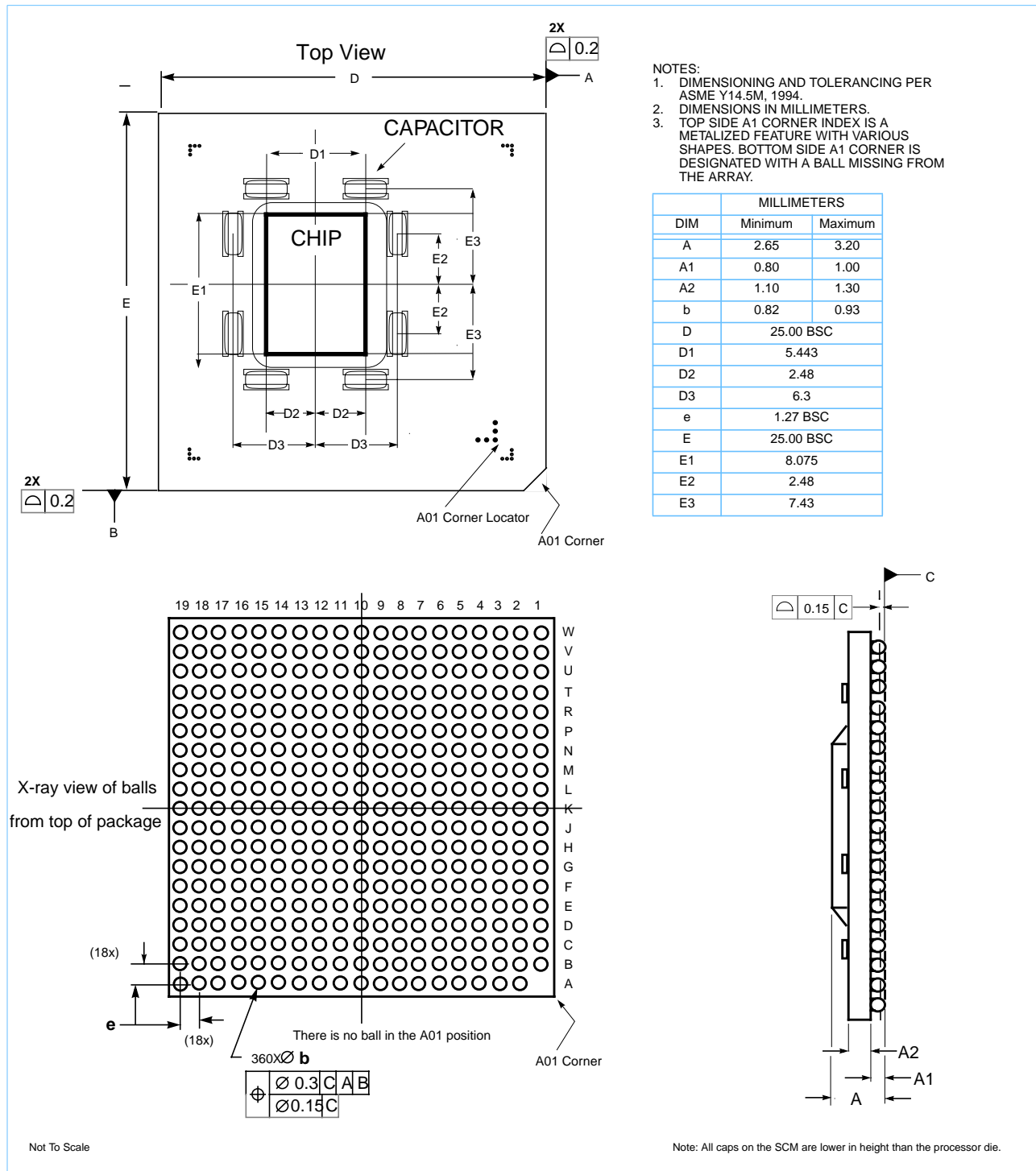
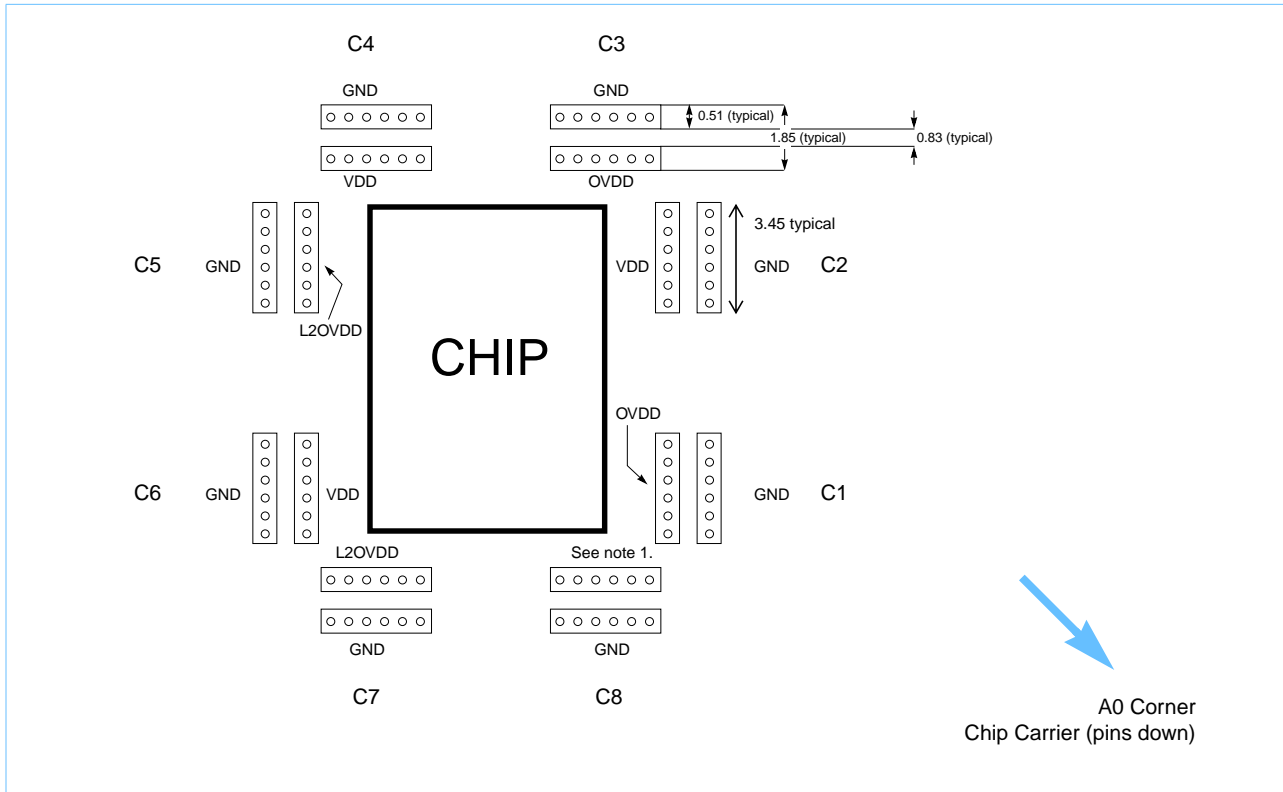

Figure 17. 360 CBGA Decoupling Capacitors



Notes:

1. For PID8 - 750 dd2.x, this capacitor is connected to Vdd. For dd3.x, this capacitor is connected to AVdd.
2. For dd3.x, AVdd is no longer brought to the BGA pin.

System Design Information

PLL Configuration

The 750 PLL is configured by the PLL_CFG[0:3] signals. For a given SYSCLK (bus) frequency, the PLL configuration signals set the internal CPU and VCO frequency of operation.

PLL Configuration

PLL_CFG (0:3)		Processor to Bus Frequency Ratio	VCO Divider ⁵
bin	dec		
0000	0	Rsv ¹	n/a
0001	1	7.5x	2
0010	2	7x	2
0011	3	PLL Bypass ³	n/a
0100	4	2x ⁶	2
0101	5	6.5x	2
0110	6	10x	2
0111	7	4.5x	2
1000	8	3x	2
1001	9	5.5x	2
1010	10	4x	2
1011	11	5x	2
1100	12	8x	2
1101	13	6x	2
1110	14	3.5x	2
1111	15	Off ⁴	n/a

Note:

1. Reserved settings.
2. SYSCLK min is limited by the lowest frequency that manufacturing will support, see Section , "Clock AC Specifications," for valid SYSCLK and VCO frequencies.
3. In PLL-bypass mode, the SYSCLK input signal clocks the internal processor directly, the PLL is disabled, and the bus mode is set for 1:1 mode operation. This mode is intended for factory use only. **Note:** The AC timing specifications given in the document do not apply in PLL-bypass mode.
4. In Clock-off mode, no clocking occurs inside the 750 regardless of the SYSCLK input.
5. The VCO to core clock ratio is 2x for 740/750. This simplifies clock frequency calculations so the user can disregard the VCO frequency. The VCO will operate correctly when the core clock is within specification.
6. Not tested.

PLL Power Supply Filtering

The AV_{DD} and L2AVdd are power signals provided on the 750 to provide power to the clock generation phase-locked loop and L2 cache delay-locked loop respectively. To ensure stability of the internal clock, the power supplied to the AV_{DD} input signal should be filtered using a circuit similar to the one shown in Figure 18. The circuit should be placed as close as possible to the AV_{DD} pin to ensure it filters out as much noise as possible. For dd3.2, AVdd is filtered on the module from Vdd for the 750 only and can be connected or not, at the designer's convenience. The 740 requires AVdd to be supplied as usual.

Figure 18. PLL Power Supply Filter Circuit

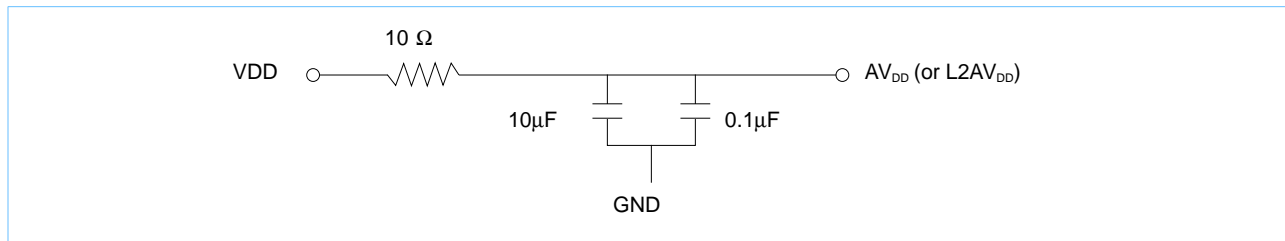

Decoupling Recommendations

Due to the dynamic power management of the 750, which features large address and data buses, as well as high operating frequencies, the 750 can generate transient power surges and high frequency noise in its power supply, especially while driving large capacitive loads. This noise must be prevented from reaching other components in the 750 system, and the 750 itself requires a clean, tightly regulated source of power. Therefore, it is strongly recommended that the system designer place at least one decoupling capacitor with a low ESR (effective series resistance) rating at each V_{DD} and OV_{DD} pin (and L2 OV_{DD} for the 360 CBGA) of the 750. It is also recommended that these decoupling capacitors receive their power from separate V_{DD} , OV_{DD} and GND power planes in the PCB, utilizing short traces to minimize inductance.

These capacitors should range in value from 220pF to 10 μF to provide both high- and low-frequency filtering, and should be placed as close as possible to their associated V_{DD} or OV_{DD} pins. Suggested values for the V_{DD} pins – 220pF (ceramic), 0.01 μF (ceramic), and 0.1 μF (ceramic). Suggested values for the OV_{DD} pins – 0.01 μF (ceramic), 0.1 μF (ceramic), and 10 μF (tantalum). Only SMT (surface-mount technology) capacitors should be used to minimize lead inductance.

In addition, it is recommended that there be several bulk storage capacitors distributed around the PCB, feeding the V_{DD} and OV_{DD} planes, to enable quick recharging of the smaller chip capacitors. These bulk capacitors should have a low ESR (equivalent series resistance) rating to ensure the quick response time necessary. They should also be connected to the power and ground planes through two vias to minimize inductance. Suggested bulk capacitors – 100 μF (AVX TPS tantalum) or 330 μF (AVX TPS tantalum).

Connection Recommendations

To ensure reliable operation, it is highly recommended to connect unused inputs to an appropriate signal level. Unused active low inputs should be tied to V_{DD} . Unused active high inputs should be connected to GND. All NC (no-connect) signals must remain unconnected.

Power and ground connections must be made to all external V_{DD} , OV_{DD} , and GND, pins of the 750.

External clock routing should ensure that the rising edge of the L2 clock is coincident at the CLK input of all SRAMs and at the L2SYNC_IN input of the 750. The L2CLKOUTA network could be used only, or the L2CLKOUTB network could also be used depending on the loading, frequency, and number of SRAMs.

Output Buffer DC Impedance

The 750 60x and L2 I/O drivers were characterized over process, voltage, and temperature. To measure Z_0 , an external resistor is connected to the chip pad, either to OV_{DD} or GND. Then the value of such resistor is varied until the pad voltage is $OV_{DD}/2$; see Figure 19, "Driver Impedance Measurement," below.

The output impedance is actually the average of two components, the resistances of the pull-up and pull-down devices. When Data is held low, SW1 is closed (SW2 is open), and R_N is trimmed until Pad = $OV_{DD}/2$. R_N then becomes the resistance of the pull-down devices. When Data is held high, SW2 is closed (SW1 is open), and R_P is trimmed until Pad = $OV_{DD}/2$. R_P then becomes the resistance of the pull-up devices. With a properly designed driver R_P and R_N are close to each other in value, then $Z_0 = (R_P + R_N)/2$.

Figure 19. Driver Impedance Measurement

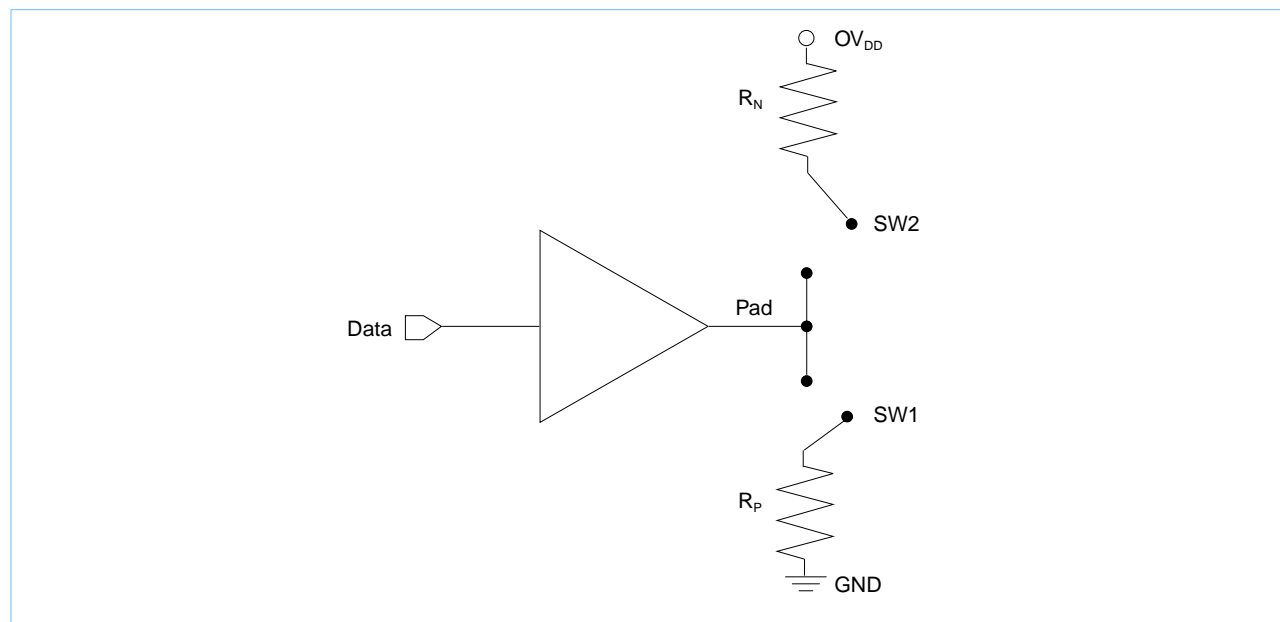

The following table summarizes the impedance a board designer would design to for a typical process. These values were derived by simulation at 65°C. As the process improves, the output impedance will be lower by several ohms than this typical value.

Impedance Characteristics

$V_{DD} = 1.9V_{DC}$, $L2OV_{DD}=OV_{DD} = 3.3V_{DC}$, $T_j = 65^\circ\text{C}$

Process	60x	L2	Symbol	Unit
Typical	43	38	Z_0	Ω



Pull-up Resistor Requirements

The 750 requires high-resistive (weak: 10K Ω) pull-up resistors on several control signals of the bus interface to maintain the control signals in the negated state after they have been actively negated and released by the 750 or other bus masters. These signals are: \overline{TS} , \overline{ABB} , \overline{DBB} , \overline{TBST} , \overline{GBL} , and \overline{ARTRY} .

In addition, the 750 has one open-drain style output that requires a pull-up resistor (weak or stronger: 4.7K Ω - 1K Ω) if it is used by the system. This signal is: $\overline{CKSTP_OUT}$.

If address or data parity is not used by the system, it should be disabled using $\overline{HID0}$. This also disables the parity input receivers. In most systems, the unused (and disabled) parity pins can be left unconnected; however, in some systems, these parity pins must be pulled up to OVdd by a weak (or stronger) pull-up.

No pull-up resistors are normally required for the L2 interface, the 60x bus address and AP lines, or the 60x bus data and DP lines. The data bus input receivers are normally turned off when no read operation is in progress and do not require pull-up resistors on the data bus.

\overline{HRESET} and \overline{GBL} must be actively driven.

Resistor Pull-up / Pull-down Requirements

Required or Recommended Actions	Signals
Strong pull-up required	$\overline{CKSTP_OUT}$
Weak pull-up required	$\overline{TLBISYNC}$, $\overline{LSSD_MODE}$, $\overline{L1_TSTCLK}$, $\overline{L2TSTCLK}$, \overline{TS} , \overline{ABB} , \overline{DBB} , \overline{ARTRY} , \overline{GBL} , \overline{TBST}
Weak pull-up or pull-down required	TCK
Weak pull-up recommended	\overline{SRESET} , \overline{SMI} , \overline{INT} , \overline{MCP} , $\overline{CKSTP_IN}$
Weak pull-up recommended if pin not used	AP[0:3], DP[0:3]

Errata Summary

#	Problem	Description	Impact	Solution(s)	Applies to Version 3.2
1	L2 cache invalidate may fail with DPM enabled.	If DPM is enabled during a global invalidate of the L2 cache, the global invalidate may not invalidate all the L2's tags.	Possible system failure after L2 initialization and start-up.	Turn DPM off during a L2 tag invalidate.	Yes
3	dcbz that hits in L1 cache may not retry snoop.	If a dcbz hits in the L1 cache, a snoop received at the same time to that address may not be serviced or get retried.	Stale data from system memory may be read by the other bus master, and the line may become valid in multiple caches.	Limit use of dcbz to data that is protected through software synchronization.	Yes
5	Segment register updates may corrupt data translation.	$\overline{mtr}<in>$ followed by an instruction causing a page data address translation can cause contention for the segment registers.	Possible access to incorrect real address locations or false translation and data access exceptions.	Insert \overline{isync} , \overline{sc} , or \overline{rfi} between any $\overline{mtr}<in>$ and instructions that cause a page data address translation.	Yes
8 (Advisory)	Stfd of uninitialized FPR can hang part.	A stfd will hang the part if its source FPR has powered up in a certain state.	Any system using a stfd.	Initialize all FPRs at POR.	Yes

Thermal Management Information

This section provides thermal management information for the CBGA package for air cooled applications. Proper thermal control design is primarily dependent upon the system-level design; that is, the heat sink, air flow, and the thermal interface material. To reduce the die-junction temperature, heat sinks may be attached to the package by several methods: adhesive, spring clip to holes in the printed-circuit board or package, and mounting clip and screw assembly, see Figure 20.

Figure 20. Package Exploded Cross-Sectional View with Several Heat Sink Options

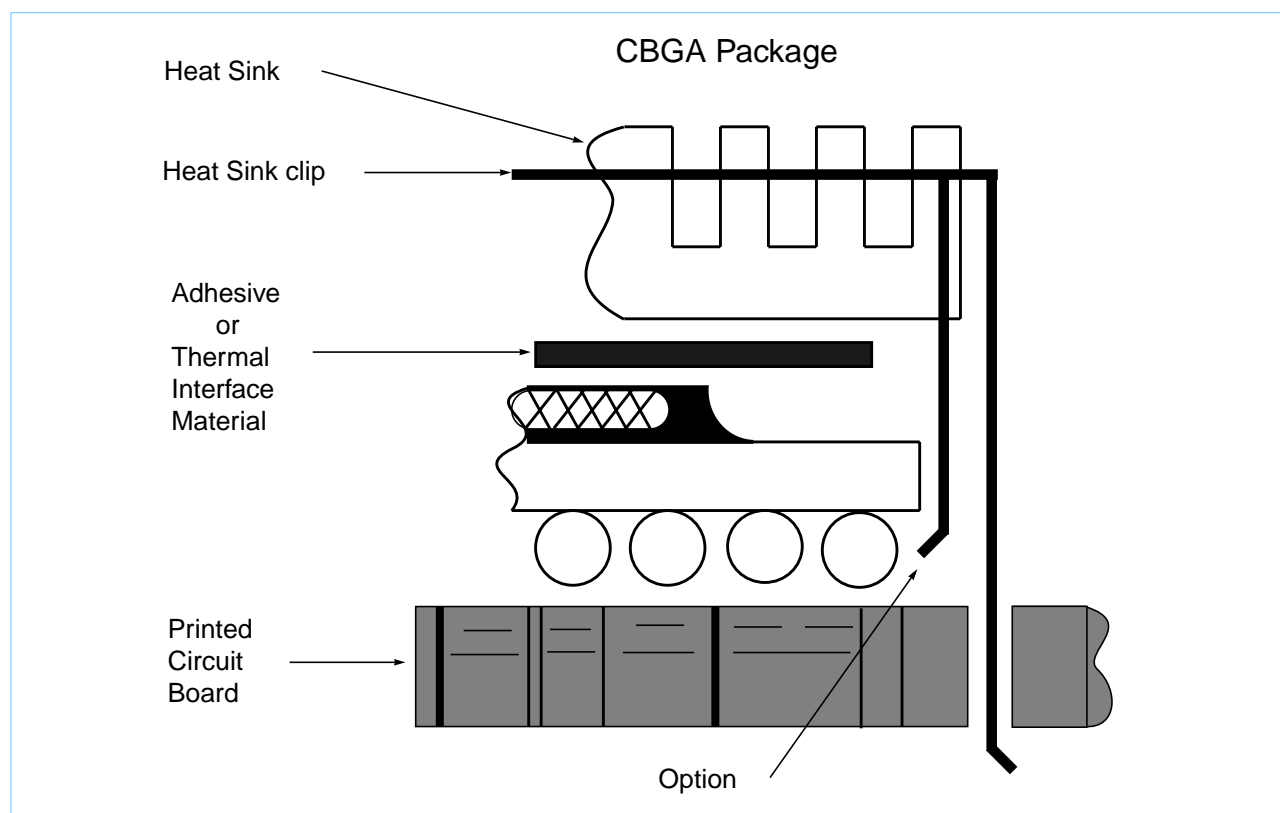

Maximum Heatsink Weight Limit for the 360 CBGA

Force	Maximum (pounds)
Dynamic Compression	10.0
Dynamic Tensile	2.5
Static Constant (Spring Force)	8.2



The board designer can choose between several types of heat sinks to place on the 750. There are several commercially-available heat sinks for the 750 provided by the following vendors:

Chip Coolers, Inc. 333 Strawberry Field Rd. Warwick, RI 02887-6979	800-227-0254 (USA/Canada) 401-739-7600
--	---

Thermalloy 2021 W. Valley View Lane P.O. Box 810839 Dallas, TX 75731	214-243-4321
---	--------------

International Electronic Research Corporation (IERC) 135 W. Magnolia Blvd. Burbank, CA 91502	818-842-7277
--	--------------

Aavid Engineering One Kool Path Laconic, NH 03247-0440	603-528-3400
--	--------------

Wakefield Engineering 60 Audubon Rd. Wakefield, MA 01880	617-245-5900
--	--------------

Ultimately, the final selection of an appropriate heat sink for the 750 depends on many factors, such as thermal performance at a given air velocity, spatial volume, mass, attachment method, assembly, and cost.

Internal Package Conduction Resistance

For the exposed-die packaging technology, shown in Table "Package Thermal Characteristics1," on page 10, the intrinsic conduction thermal resistance paths are as follows.

- Die junction-to-case thermal resistance
- Die junction-to-ball thermal resistance

Figure 21 depicts the primary heat transfer path for a package with an attached heat sink mounted to a printed-circuit board.

Figure 21. C4 Package with Heat Sink Mounted to a Printed-Circuit Board

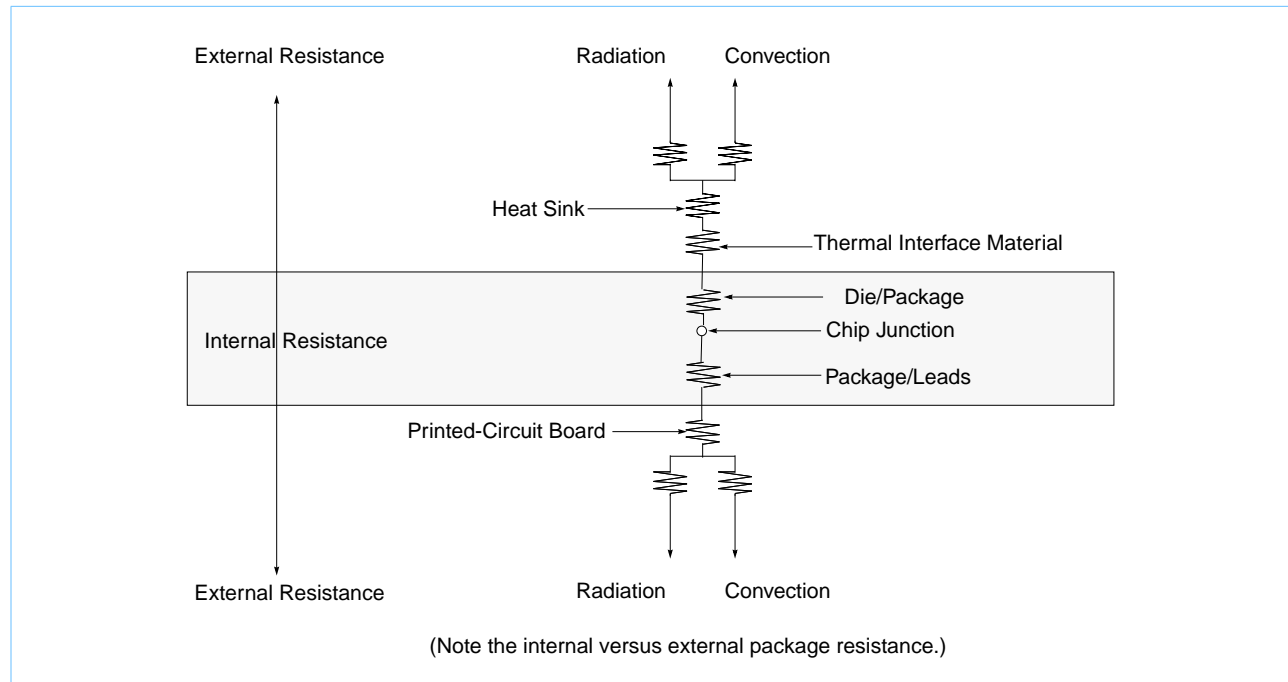

Heat generated on the active side (ball) of the chip is conducted through the silicon, then through the heat sink attach material (or thermal interface material), and finally to the heat sink; where it is removed by forced-air convection. Since the silicon thermal resistance is quite small, for a first-order analysis, the temperature drop in the silicon may be neglected. Thus, the heat sink attach material and the heat sink conduction/conductive thermal resistances are the dominant terms.

Adhesives and Thermal Interface Materials

A thermal interface material is recommended at the package lid-to-heat sink interface to minimize the thermal contact resistance. For those applications where the heat sink is attached by a spring clip mechanism, Figure 22 shows the thermal performance of three thin-sheet thermal-interface materials (silicon, graphite/oil, fluoroether oil), a bare joint, and a joint with thermal grease, as a function of contact pressure. As shown, the performance of these thermal interface materials improves with increasing contact pressure. The use of thermal grease significantly reduces the interface thermal resistance. That is, the bare joint results in a thermal resistance approximately 7 times greater than the thermal grease joint.

Heat sinks are attached to the package by means of a spring clip to holes in the printed-circuit board (see Figure 20). Therefore the synthetic grease offers the best thermal performance, considering the low interface pressure. Of course, the selection of any thermal interface material depends on many factors – thermal performance requirements, manufacturability, service temperature, dielectric properties, cost, etc.

Figure 22. Thermal Performance of Select Thermal Interface Material

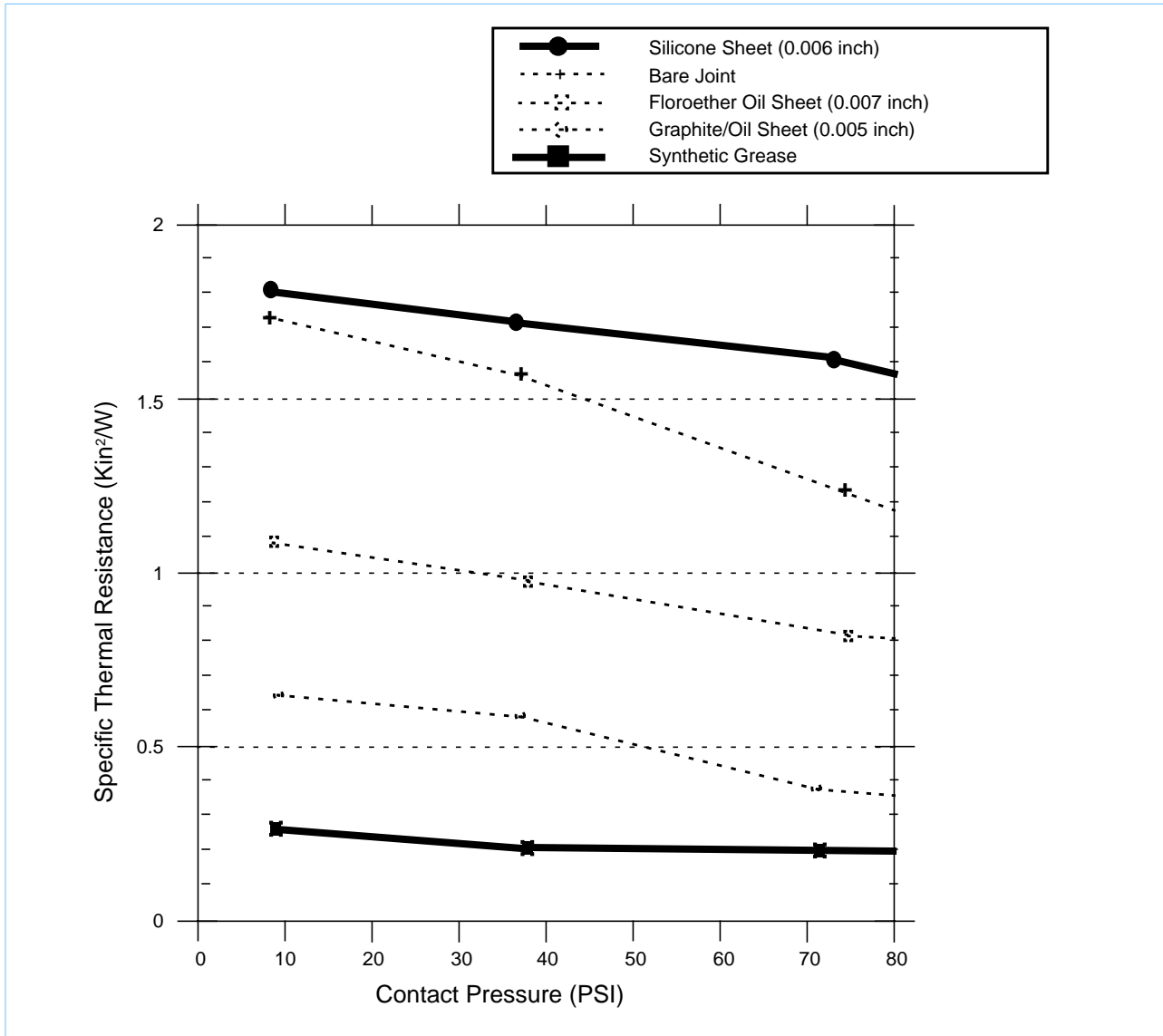

The board designer can choose between several types of thermal interfaces. Heat sink adhesive materials should be selected based upon high conductivity, yet adequate mechanical strength to meet equipment shock/vibration requirements. There are several commercially-available thermal interfaces and adhesive materials provided by the following vendors.

Dow-Corning Corporation
 Dow-Corning Electronic Materials
 P.O. Box 0997
 Midland, MI 48686-0997

517-496-4000

Chomerics, Inc. 617-935-4850
 77 Dragon Court
 Woburn, MA 01888-4850

Thermagon, Inc. 216-741-7659
 3256 West 25th Street
 Cleveland, OH 44109-1668

Loctite Corporation 860-571-5100
 1001 Trout Brook Crossing
 Rocky Hill, CT 06067

AI Technology (e.g. EG7655) 609-882-2332
 1425 Lower Ferry Road
 Trent, NJ 08618

The following section provides a heat sink selection example using one of the commercially available heat sinks.

Heat Sink Selection Example

For preliminary heat sink sizing, the die-junction temperature can be expressed as follows.

$$T_J = T_A + T_R + (\theta_{JC} + \theta_{INT} + \theta_{SA}) \times P_D$$

Where:

- T_J is the die-junction temperature
- T_A is the inlet cabinet ambient temperature
- T_R is the air temperature rise within the system cabinet
- θ_{JC} is the junction-to-case thermal resistance
- θ_{INT} is the thermal resistance of the thermal interface material
- θ_{SA} is the heat sink-to-ambient thermal resistance
- P_D is the power dissipated by the device

Typical die-junction temperatures (T_J) should be maintained less than the value specified in Table "Package Thermal Characteristics1," on page 10. The temperature of the air cooling the component greatly depends upon the ambient inlet air temperature and the air temperature rise within the computer cabinet. An electronic cabinet inlet-air temperature (T_A) may range from 30 to 40°C. The air temperature rise within a cabinet (T_R) may be in the range of 5 to 10°C. The thermal resistance of the interface material (θ_{INT}) is typically about 1°C/W. Assuming a T_A of 30°C, a T_R of 5°C, a CBGA package $\theta_{JC} = 0.03$, and a power dissipation (P_D) of 5.0 watts, the following expression for T_J is obtained.

$$\text{Die-junction temperature: } T_J = 30^\circ\text{C} + 5^\circ\text{C} + (0.03^\circ\text{C/W} + 1.0^\circ\text{C/W} + \theta_{SA}) \times 5\text{W}$$

For a Thermalloy heat sink #2328B, the heat sink-to-ambient thermal resistance (θ_{SA}) versus air flow velocity is shown in Figure 23.

Figure 23. Thermalloy #2328B Pin-Fin Heat Sink-to-Ambient Thermal Resistance vs. Air flow Velocity

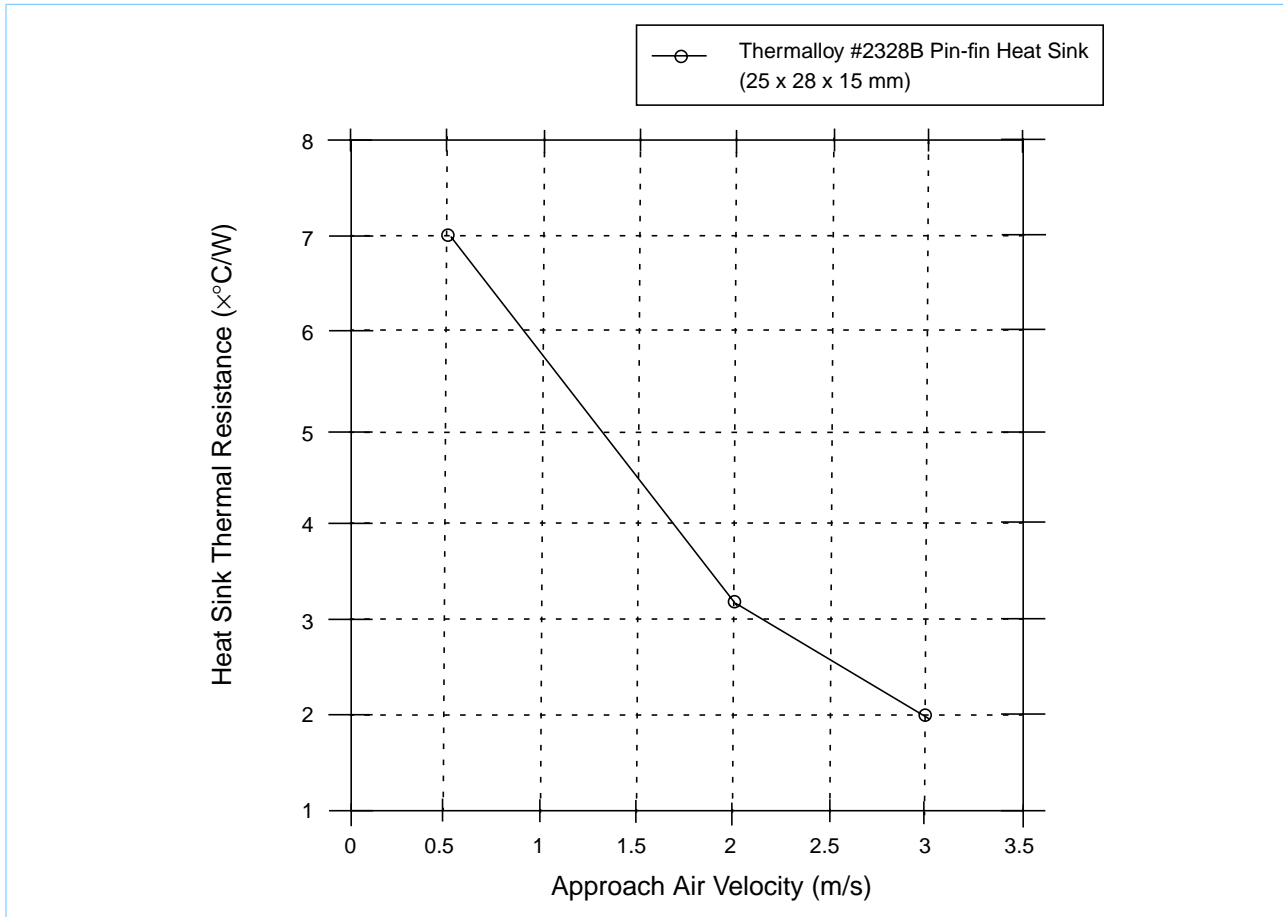

Assuming an air velocity of 0.5m/s, we have an effective θ_{SA} of $7^{\circ}\text{C}/\text{W}$, thus

$$T_j = 30^{\circ}\text{C} + 5^{\circ}\text{C} + (.03^{\circ}\text{C}/\text{W} + 1.0^{\circ}\text{C}/\text{W} + 7^{\circ}\text{C}/\text{W}) \times 4.5\text{W},$$

resulting in a junction temperature of approximately 71°C which is well within the maximum operating temperature of the component.

Other heat sinks offered by Chip Coolers, IERC, Thermalloy, Aavid, and Wakefield Engineering offer different heat sink-to-ambient thermal resistances, and may or may not need air flow.

Though the junction-to-ambient and the heat sink-to-ambient thermal resistances are a common figure-of-merit used for comparing the thermal performance of various microelectronic packaging technologies, one should exercise caution when only using this metric in determining thermal management because no single parameter can adequately describe three-dimensional heat flow. The final chip-junction operating temperature is not only a function of the component-level thermal resistance, but the system-level design and its operating conditions. In addition to the component's power dissipation, a number of factors affect the final operating die-junction temperature. These factors might include air flow, board population (local heat flux of adjacent components), heat sink efficiency, heat sink attach, next-level interconnect technology, system air temperature rise, etc.

Ordering Information

This section provides the part numbering nomenclature for the 750. Note that the individual part numbers correspond to a maximum processor core frequency. For available devices contact your local IBM sales office.

Figure 24. Part Number Key

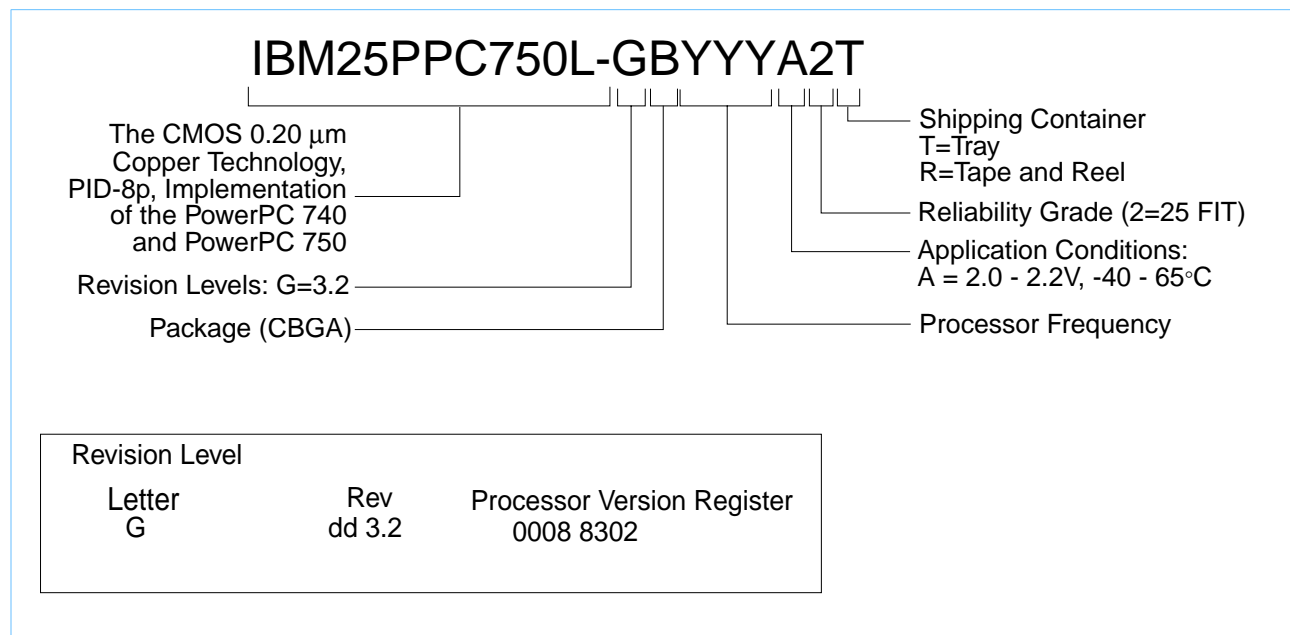





© International Business Machines Corporation 1999

Printed in the United States of America

12/99

All Rights Reserved

The information contained in this document is subject to change without notice. The products described in this document are NOT intended for use in implantation or other life support applications where malfunction may result in injury or death to persons. The information contained in this document does not affect or change IBM's product specifications or warranties. Nothing in this document shall operate as an express or implied license or indemnity under the intellectual property rights of IBM or third parties. All information contained in this document was obtained in specific environments, and is presented as illustration. The results obtained in other operating environments may vary.

While the information contained herein is believed to be accurate, such information is preliminary, and should not be relied upon for accuracy or completeness, and no representations or warranties of accuracy or completeness are made.

THE INFORMATION CONTAINED IN THIS DOCUMENT IS PROVIDED ON AN "AS IS" BASIS. In no event will IBM be liable for any damages arising directly or indirectly from any use of the information contained in this document.

IBM Microelectronics Division
1580 Route 52, Bldg. 504
Hopewell Junction, NY
12533-6531

The IBM home page can be found at <http://www.ibm.com>

The IBM Microelectronics Division home page can be found at <http://www.chips.ibm.com>