

Phase Shifters

Harmonic Type

250 ° Field Adjustable Phase Shift

- High Frequency Harmonic Phase Adjustment
- Low VSWR and Insertion Loss
- Smooth Continuous Adjustment
- Meets Mil-E-5400 and Mil-E16400 Environment

Midwest Microwave's series of higher frequency Harmonic Phase Shifters provide continuous phase adjustability while exhibiting high performance characteristics throughout their operating frequency range. They are small, lightweight, ruggedly constructed units that possess consistently low VSWR and linear insertion loss. They are completely field adjustable through the use of a smooth, and simple mechanical adjustment.



SPECIFICATIONS

Fundamental Frequency: 7.5-9.0 GHz and 6.5-9.0 GHz,

Harmonic Frequency: 15.0- 17.0, and 13.0-18.0 GHz

Impedance: 50 Ohms

VSWR: 1.7:1 in Fundamental frequency band typical

2.0:1 in harmonic frequency band typical

see table below

Insertion Loss: 0.8 dB max in fundamental frequency band

1.0 dB max in harmonic frequency band

Power: 2 Watts average, 2 Watts Peak

Operating Temperature: -55 °C - +125 °C

Connectors: Passivated Stainless Steel SMA*

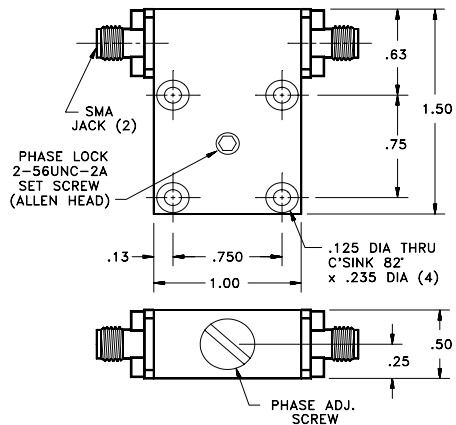

Model No. PHS-6008-FF-SMA-79

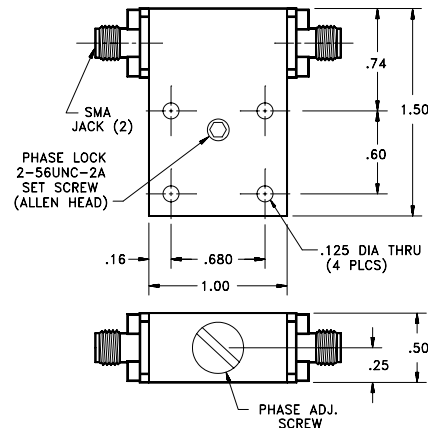

Model No. PHS-6009-FF-SMA-79

Frequency (GHz)		Model Number	Harmonic Phase Shift (degrees)	VSWR		Insertion Loss	
Fundamental	Harmonic			Fundamental	Harmonic	Fundamental	Harmonic
7.5 - 9.0	15.0 - 17.0	PHS-6008-FF-SMA-79	250	1.60	1.80	0.80	1.00
6.5 - 9.0	13.0 - 18.0	PHS-6009-FF-SMA-79	180	1.60	1.80	0.90	1.00

Note: SMA male, TNC, or Type N output connectors, either male or female, are also available by substituting TNC or NNN for SMA in the Model Number. If an interface gender change is desired, substitute MM or MF for FF in the Model Number. Please note that the housing thickness will increase accordingly when larger connectors are selected.