

### RS5RJ SERIES

#### OUTLINE

The RS5RJ series are step-up DC/DC converter ICs equipped with a voltage regulator (VR) and a voltage detector (VD) by CMOS process. Each of these step-up DC/DC converter ICs consists of a VFM DC/DC converter, a linear regulator and a voltage detector. These ICs are output-voltage-fixed type regulators which function as a linear regulator when input voltage is high, and as step-up DC/DC converter + linear regulator when input voltage is low, by using an inductor, a diode and a capacitor as external parts for the ICs.

Since a voltage detector is built in these ICs, the potentials such as the output voltage of DC/DC converters can be monitored.

In addition, these step-up DC/DC converter ICs are suitable for battery-powered and hand-held instruments because internal circuits can be turned off by the chip enable function so that the standby current can be minimized.

#### FEATURES

- Low Supply Current .....TYP. 15 $\mu$ A (RS5RJ3624A :  $V_{IN}=3.0V$ , at no load)
- Standby Mode .....Istandby=MAX. 1.0 $\mu$ A (RS5RJXXXXA)  
.....Istandby=MAX. 10.0 $\mu$ A (RS5RJXXXXB)
- Low Voltage Operation Possible .....Operating Voltage  $V_{IN}=1.2V$  to 10V
- High Output Voltage Accuracy .....Fixed Output Voltage Accuracy $\pm 2.5\%$
- High Detector Threshold Accuracy .....Accuracy $\pm 2.5\%$
- Output Voltage can be set at User's request (refer to Selection Guide).
- Voltage close to battery's voltage can be output because these ICs are of a step-up / step-down type (Ex. a fixed voltage of 3V can be output by a 3V battery).
- Built-in Protection Circuits for Lx Driver
- Pin for External Driver is equipped, and a large current output can be obtained.
- Small Package .....8pin SOP

#### APPLICATIONS

- Power source for cameras, camcorders, and hand-held audio equipment.
- Power source for small OA apparatus such as note type personal computers, and word processors.
- Power source for hand-held communication appliances such as pagers, cordless telephones, and cellular phones.

## BLOCK DIAGRAM

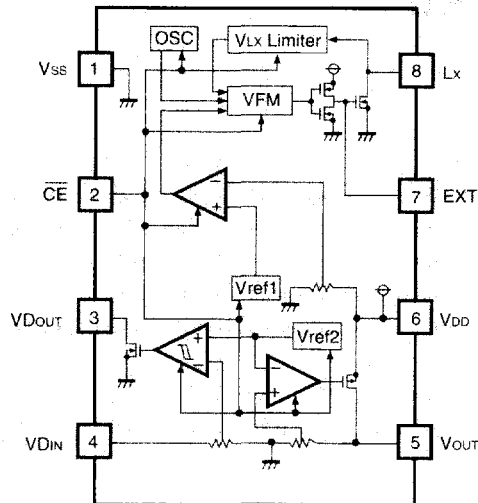

## SELECTION GUIDE

In the RS5RJ Series, the output voltage, the detector threshold, the version symbols, and the taping type for the ICs can be selected at the user's request.

The selection can be made by designating the part number as shown below:

RS5RJ  $\overset{\uparrow}{\times} \overset{\uparrow}{\times} \overset{\uparrow}{\times} \overset{\uparrow}{\times} \overset{\uparrow}{\times} - \overset{\uparrow}{\times} \overset{\uparrow}{\times}$  ← Part Number  
           a   b   c   d

Code	Contents
a	Setting Output Voltage (V <sub>OUT</sub> ): Stepwise setting with a step of 0.6V in the range of 1.5V to 6.0V is possible.
b	Setting Detector Threshold Voltage (–V <sub>DET</sub> ): Stepwise setting with a step of 0.1V in the range of 1.2V to 5.0V is possible.
c	Designation of Version Symbols: A: Operation of all the internal circuits is stopped by setting $\overline{\text{CE}}$ pin at V <sub>DD</sub> level. B: Operation of only Step-up DC/DC converter is stopped by setting $\overline{\text{CE}}$ pin at V <sub>DD</sub> level.
d	Designation of Taping Type: Ex. 8pin SOP : T1, T2 (refer to Taping Specification) "T2" is prescribed as a standard.

For example, the product with Output Voltage 5.0V, Detector Threshold 4.5V, Version A, and Taping Type T1, is designated by Part Number RS5RJ5045A-T1.

## PIN CONFIGURATION

• 8pin SOP

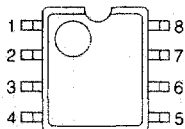

## PIN DESCRIPTION

Pin No.	Symbol	Pin Description
1	VSS	Ground Pin
2	$\overline{\text{CE}}$	Chip Enable Pin
3	VDOUT	Voltage Detector Output Pin. Nch Open Drain Output
4	VDIN	Detection Input Pin of Voltage Detector
5	VOUT	Output Pin for Regulator
6	VDD	Step-up Output. Power Supply Pin
7	EXT	External Transistor Drive Pin
8	LX	External Inductor Drive Pin.

## ABSOLUTE MAXIMUM RATINGS

T<sub>opt</sub>=25°C, V<sub>SS</sub>=0V

Symbol	Item		Rating	Unit	
VDD	Supply Voltage		-0.3 to +12	V	
VLX	Output Voltage	LX Pin Voltage	V <sub>SS</sub> -0.3 to +12	V	
VEXT		EXT Pin Voltage	V <sub>SS</sub> -0.3 to VDD+0.3	V	
VOUT		VOUT Pin Voltage	V <sub>SS</sub> -0.3 to VDD+0.3	V	
VDOUT		VDOUT Pin Voltage	V <sub>SS</sub> -0.3 to +12	V	
VCE	Input Voltage	$\overline{\text{CE}}$ Pin Voltage	V <sub>SS</sub> -0.3 to VDD+0.3	V	
VDIN		VDIN Pin Voltage	A Version	V <sub>SS</sub> -0.3 to VDD+0.3	V
			B Version	V <sub>SS</sub> -0.3 to +12	
ILX	Inductor Drive Output Current	Lx Pin Current	250	mA	
IEXT		EXT Pin Current	50	mA	
P <sub>D</sub>	Power Dissipation		300	mW	
T <sub>opt</sub>	Operating Temperature Range		-30 to +80	°C	
T <sub>stg</sub>	Storage Temperature Range		-55 to +125	°C	
T <sub>solder</sub>	Lead Temperature (Soldering)		260°C, 10s		

## ABSOLUTE MAXIMUM RATINGS

Absolute Maximum ratings are threshold limit values that must not be exceeded even for an instant under any conditions. Moreover, such values for any two items must not be reached simultaneously. Operation above these absolute maximum ratings may cause degradation or permanent damage to the device. These are stress ratings only and do not necessarily imply functional operation below these limits.

## ELECTRICAL CHARACTERISTICS

• RS5RJ3624A,B

T<sub>opt</sub>=25°C

Symbol	Item	Conditions	MIN.	TYP.	MAX.	Unit	Note
V <sub>IN</sub>	Operation Input Voltage	No load	1.2		10	V	
V <sub>DD</sub>	Step-up Output Voltage	No load	3.99	4.1	4.21	V	
V <sub>oscst</sub>	Oscillator Start-up Voltage	No load		0.9	1.2	V	
V <sub>hold</sub>	Hold-on Voltage	I <sub>OUT</sub> =1mA	0.7			V	
f <sub>osc</sub>	Maximum Oscillator Frequency		80	100	120	kHz	
Maxdty	Oscillator Duty Cycle		65	80	90	%	
V <sub>OL1</sub>	Lx Output Voltage	I <sub>OL</sub> =50mA			0.5	V	
I <sub>OH1</sub>	Lx Leakage Current			0.01	10	μA	
V <sub>LXlim</sub>	Lx Voltage Limit	Lx Pin On		0.9		V	
V <sub>OH</sub>	EXT Output Pch ON Voltage	I <sub>EXT</sub> =-3mA, V <sub>DD</sub> =4.1V	3.6			V	
V <sub>OL2</sub>	EXT Output Nch ON Voltage	I <sub>EXT</sub> =5mA, V <sub>DD</sub> =4.1V			0.5	V	
V <sub>OUT</sub>	Output Voltage	I <sub>RL</sub> =-5mA	3.51	3.6	3.69	V	
V <sub>DIF</sub>	Dropout Voltage	I <sub>RL</sub> =-30mA		0.3		V	
ΔV <sub>OUT</sub> /ΔI <sub>OUT</sub>	Load Regulation	-30mA ≤ I <sub>RL</sub> ≤ 0mA			100	mV	
-V <sub>DET</sub>	Detector Threshold		2.34	2.4	2.46	V	
V <sub>HYS</sub>	Detector Threshold Hysteresis		60	120	240	mV	
V <sub>OL3</sub>	V <sub>DOUT</sub> ON Voltage	I <sub>OL</sub> =5mA			0.5	V	
I <sub>OH2</sub>	V <sub>DOUT</sub> Leakage Current			0.01	5	μA	
I <sub>VDINH</sub>	V <sub>DIN</sub> "H" Input Current	V <sub>DIN</sub> =V <sub>DD</sub>			5	μA	
I <sub>VDINL</sub>	V <sub>DIN</sub> "L" Input Current	V <sub>DIN</sub> =V <sub>SS</sub>	-0.5		0.5	μA	
V <sub>CEH</sub>	$\overline{\text{CE}}$ "H" Input Voltage		V <sub>DD</sub> -0.3		V <sub>DD</sub>	V	
V <sub>CEL</sub>	$\overline{\text{CE}}$ "L" Input Voltage		0		0.2V <sub>DD</sub>	V	
I <sub>CEH</sub>	$\overline{\text{CE}}$ "H" Input Current	$\overline{\text{CE}}$ =V <sub>DD</sub>	-0.5		0.5	μA	
I <sub>CEL</sub>	$\overline{\text{CE}}$ "L" Input Current	$\overline{\text{CE}}$ =V <sub>SS</sub>	-0.5		0.5	μA	
I <sub>DD</sub>	Supply Current	V <sub>IN</sub> =3V, L=100μH, C=22μF, $\overline{\text{CE}}$ =V <sub>SS</sub> , No load		15	30	μA	
I <sub>standby</sub>	Standby Current	V <sub>IN</sub> =3V, L=100μH, C=22μF, $\overline{\text{CE}}$ =V <sub>DD</sub> , No load			1.0	μA	Note1
					10.0	μA	Note2

(Note 1) Standby current of Version A

(Note 2) Standby current of Version B

Please refer to Basic Circuit for Test Circuit.

## • RS5RJ5045A,B

T<sub>opt</sub>=25°C

Symbol	Item	Conditions	MIN.	TYP.	MAX.	Unit	Note
V <sub>IN</sub>	Operation Input Voltage	No load	1.2		10	V	
V <sub>DD</sub>	Step-up Output Voltage	No load	5.36	5.5	5.64	V	
V <sub>oscst</sub>	Oscillator Start-up Voltage	No load		0.9	1.2	V	
V <sub>hold</sub>	Hold-on Voltage	I <sub>OUT</sub> =1mA	0.7			V	
f <sub>osc</sub>	Maximum Oscillator Frequency		80	100	120	kHz	
Maxdty	Oscillator Duty Cycle		65	80	90	%	
V <sub>OL1</sub>	Lx Output Voltage	I <sub>OL</sub> =50mA			0.5	V	
I <sub>OH1</sub>	Lx Leakage Current			0.01	10	μA	
V <sub>LXlim</sub>	Lx Voltage Limit	Lx Pin On		0.9		V	
V <sub>OH</sub>	EXT Output Pch ON Voltage	I <sub>EXT</sub> =-3mA, V <sub>DD</sub> =5.5V	5.0			V	
V <sub>OL2</sub>	EXT Output Nch ON Voltage	I <sub>EXT</sub> =5mA, V <sub>DD</sub> =5.5V			0.5	V	
V <sub>OUT</sub>	Output Voltage	I <sub>RL</sub> =-5mA	4.87	5.0	5.13	V	
V <sub>DIF</sub>	Dropout Voltage	I <sub>RL</sub> =-30mA		0.3		V	
ΔV <sub>OUT</sub> /ΔI <sub>OUT</sub>	Load Regulation	-30mA ≤ I <sub>RL</sub> ≤ 0mA			100	mV	
-V <sub>DET</sub>	Detector Threshold		4.38	4.5	4.62	V	
V <sub>HYS</sub>	Detector Threshold Hysteresis		112	225	450	mV	
V <sub>OL3</sub>	VDOUT ON Voltage	I <sub>OL</sub> =5mA			0.5	V	
I <sub>OH2</sub>	VDOUT Leakage Current			0.01	5	μA	
I <sub>VDINH</sub>	VDIN "H" Input Current	V <sub>DIN</sub> =V <sub>DD</sub>			5	μA	
I <sub>VDINL</sub>	VDIN "L" Input Current	V <sub>DIN</sub> =V <sub>SS</sub>	-0.5		0.5	μA	
V <sub>CEH</sub>	$\overline{\text{CE}}$ "H" Input Voltage		V <sub>DD</sub> -0.3		V <sub>DD</sub>	V	
V <sub>CEL</sub>	$\overline{\text{CE}}$ "L" Input Voltage		0		0.2V <sub>DD</sub>	V	
I <sub>CEH</sub>	$\overline{\text{CE}}$ "H" Input Current	$\overline{\text{CE}}$ =V <sub>DD</sub>	-0.5		0.5	μA	
I <sub>CEL</sub>	$\overline{\text{CE}}$ "L" Input Current	$\overline{\text{CE}}$ =V <sub>SS</sub>	-0.5		0.5	μA	
I <sub>DD</sub>	Supply Current	V <sub>IN</sub> =4V, L=100μH, C=22μF, $\overline{\text{CE}}$ =V <sub>SS</sub> , No load		20	40	μA	
I <sub>standby</sub>	Standby Current	V <sub>IN</sub> =4V, L=100μH, C=22μF, $\overline{\text{CE}}$ =V <sub>DD</sub> , No load			1.0	μA	Note1
					10.0	μA	Note2

(Note 1) Standby current of Version A

(Note 2) Standby current of Version B

Please refer to Basic Circuit for Test Circuit.

## OPERATION OF STEP-UP DC/DC CONVERTER

Step-up DC/DC Converter charges energy in the inductor when LxTr Transistor (LxTr) is ON, and discharges the energy with the addition of the energy from Input Power Source thereto when LxTr is OFF, so that a higher output voltage than the input voltage is obtained.

The operation will be explained with reference to the following diagrams:

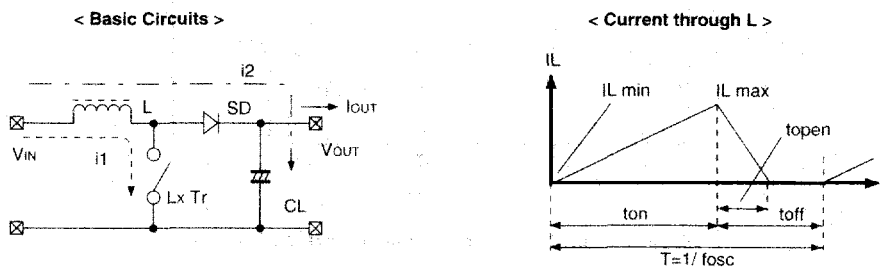

Step.1 : LxTr is turned ON and current  $I_L (= i_1)$  flows, so that energy is charged in L. At this moment,  $I_L (= i_1)$  is increased from  $I_{Lmin} (= 0)$  to reach  $I_{Lmax}$  in proportion to the on-time period ( $t_{on}$ ) of LxTr.

Step.2 : When LxTr is turned OFF, Schottky diode (SD) is turned ON in order that L maintains  $I_L$  at  $I_{Lmax}$ , so that current  $I_L (= i_2)$  is released.

Step.3 :  $I_L (= i_2)$  is gradually decreased, and in the case of discontinuous mode,  $I_L$  reaches  $I_{Lmin} (= 0)$  after a time period of  $t_{open}$ , so that SD is turned OFF.

In the case of the VFM control system, with the on-time period ( $t_{on}$ ) maintained constant, the output voltage is maintained constant by controlling the oscillator frequency ( $f_{osc}$ ).

(Note) Please refer to the Application Manual for "RH5RI SEREIS" for details.

## OPERATION

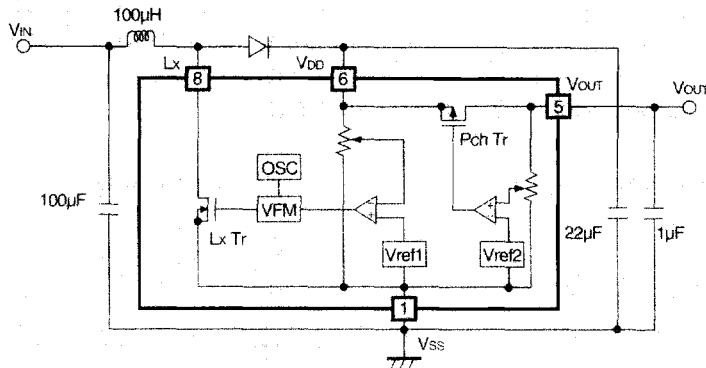

FIG. A Diagram of RS5RJ including external circuits

### 1. VDD Output Voltage

VDD output voltage is shown in Fig. B.

- (1) In the case of  $V_{IN} - V_f \geq V_{DD0}$ :

In Area B, LxTr is maintained in an OFF state, so that  $V_{IN} - V_f$  (V) is output as it is from VDD pin without step-up operation.

- (2) In the case of  $V_{IN} - V_f < V_{DD0}$ :

In Area A, this IC functions as Step-up DC/DC converter. The step-up operation will now be explained with reference to FIG. A. The step-up operation is an operation for regulating the VDD output voltage by comparing Vref1 and the VDD output voltage by error amplifier circuits and subjecting LxTr to on-time control by VFM circuits (i.e., by controlling the step-up operation).

### 2. VOUT Output Voltage

A constant voltage is output from VOUT pin, with above-mentioned the VDD output voltage being subjected to a step-down operation by a linear regulator. This step-down operation will now be explained with reference to FIG. A. The step-down operation is an operation for regulating the VDD output voltage by Pch Tr by comparing Vref2 and the VDD output voltage.

$V_{IN}$  : Input Voltage  
 $V_{DD0}$  : VDD Set Voltage  
 $V_{OUT0}$  : VOUT Set Voltage  
 $V_f$  : ON Voltage of Diode

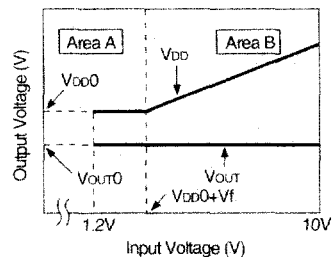
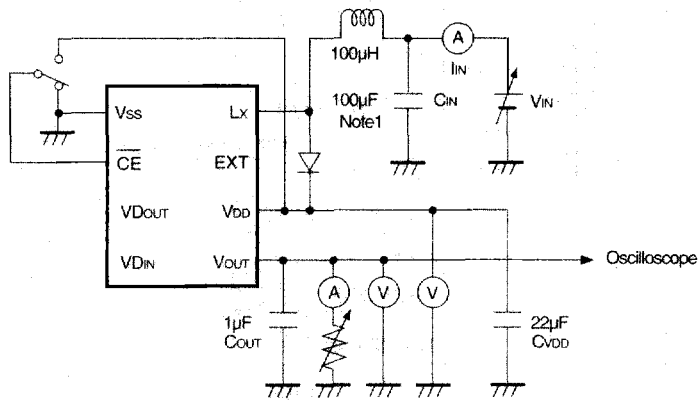

FIG. B Output Voltage vs. Input Voltage characteristic



# TEST CIRCUITS



Test Circuit 1

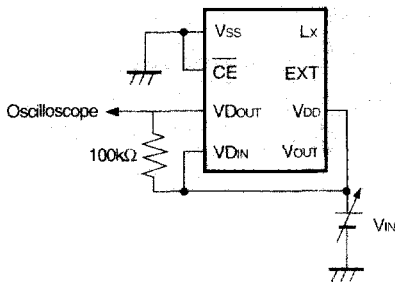

Test Circuit 2

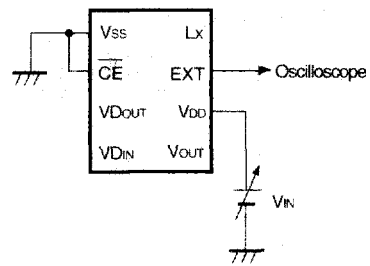

Test Circuit 3

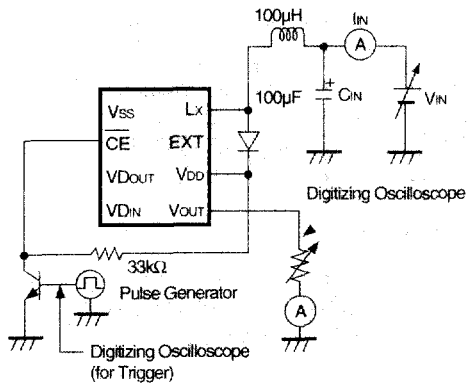

Test Circuit 4

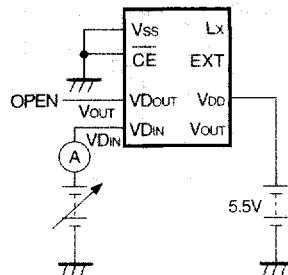

Test Circuit 5

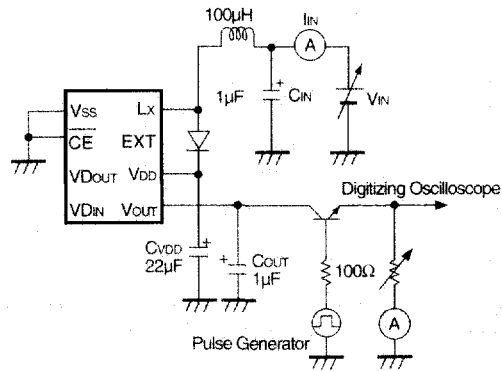

Test Circuit 6

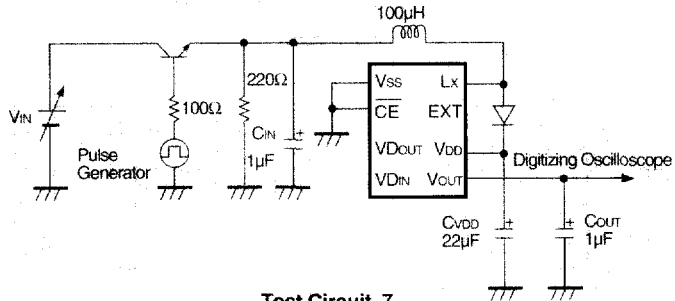

Test Circuit 7

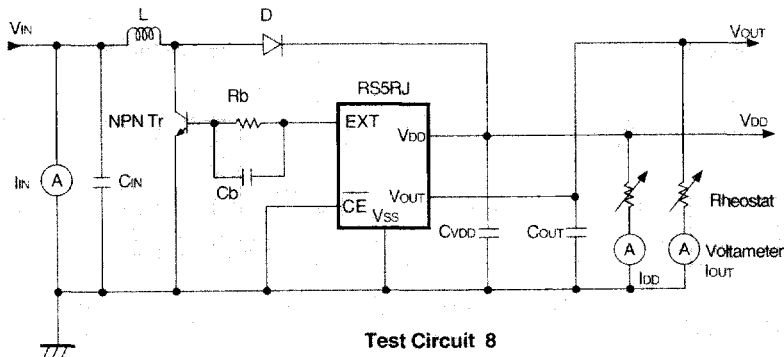

Test Circuit 8

- |     |                                    |      |                                    |
|-----|------------------------------------|------|------------------------------------|
| L   | :47µH(SUMIDA ELECTRIC CD105)       | Cb   | :0.01µF                            |
| D   | :Schotky Diode (HITACHI HRP22)     | CVDD | :220µF(Aluminum electrolytic Type) |
| CIN | :220µF(Aluminum electrolytic Type) | COUT | :1µF(Tantalum Type)                |
| Rb  | :220Ω                              |      |                                    |

By use of these test circuits, the typical characteristics were obtained as shown in the following pages:

- Test Circuit 1: Typical Characteristics 1) 2) 3) 4) 5) 9) 10) 13) 14) 16)  
(Typical Characteristics 13) and 14) were measured by replacing the capacitor shown in Note 1 with a 1 $\mu$ F Capacitor)
- Test Circuit 2: Typical Characteristics 11) 12)
- Test Circuit 3: Typical Characteristics 7) 8)  
Efficiency  $\eta$  is shown by the following formula:  
$$\eta = (V_{OUT} \times I_{OUT}) / (V_{IN} \times I_{IN})$$
- Test Circuit 4: Typical Characteristics 6)
- Test Circuit 5: Typical Characteristics 15)
- Test Circuit 6: Typical Characteristics 17)
- Test Circuit 7: Typical Characteristics 18)
- Test Circuit 8: Typical Characteristics 19) 20)

In the present IC, input current at no load is defined as supply current. ( $\overline{CE} = V_{SS}$ ).

And when  $\overline{CE} = V_{DD}$ , the input current (no load) is defined as standby current.

## TYPICAL CHARACTERISTICS

### 1) Output Voltage vs. Input Voltage (T<sub>opt</sub>=25°C)

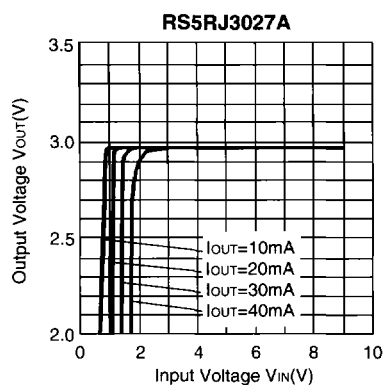
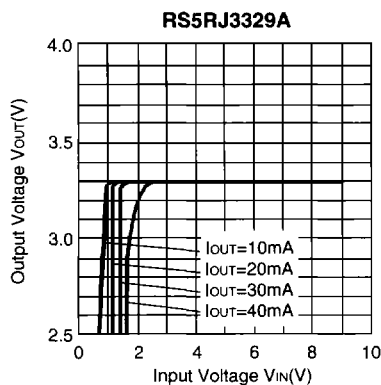
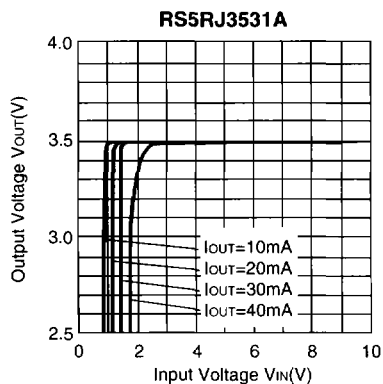
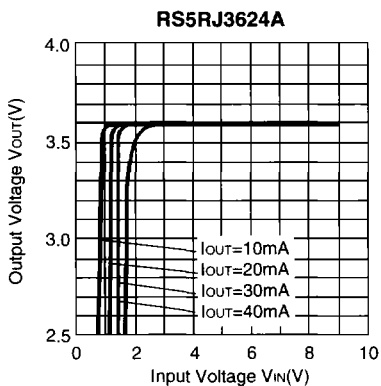
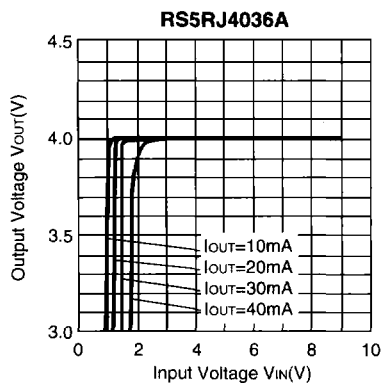
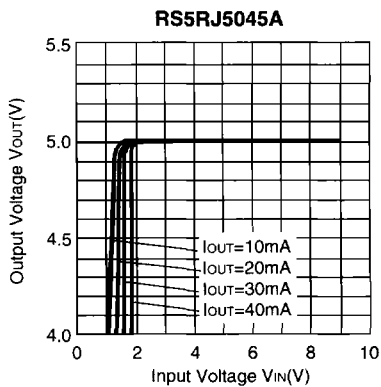

2) Output Voltage vs. Output Current (T<sub>opt</sub>=25°C)

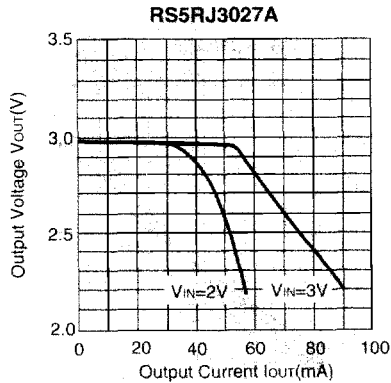
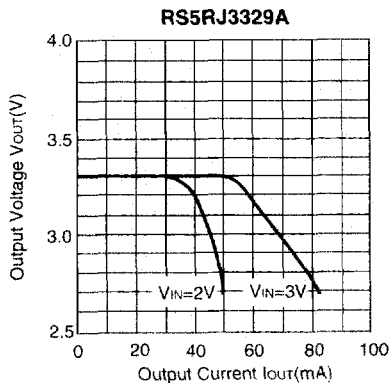
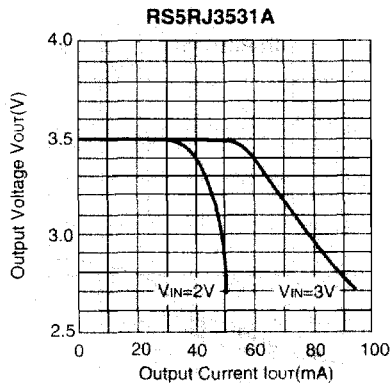
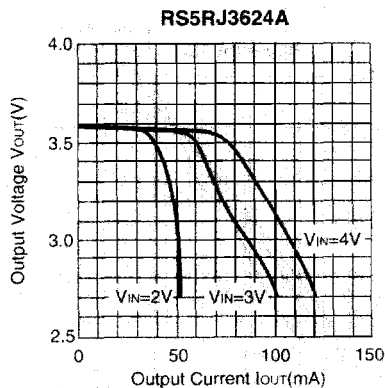
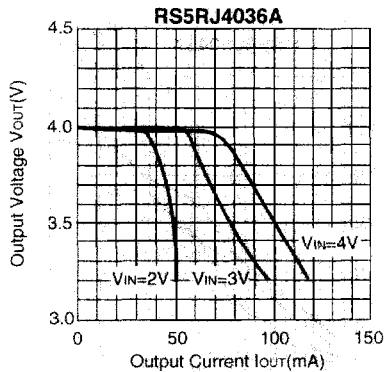
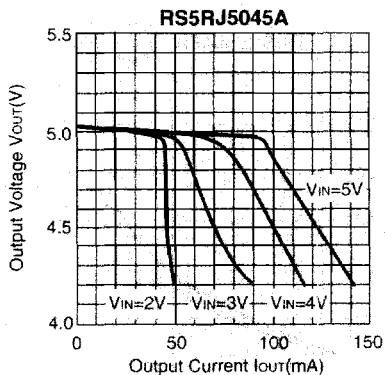

3) Ripple Voltage vs. Output Current (Topt=25°C)

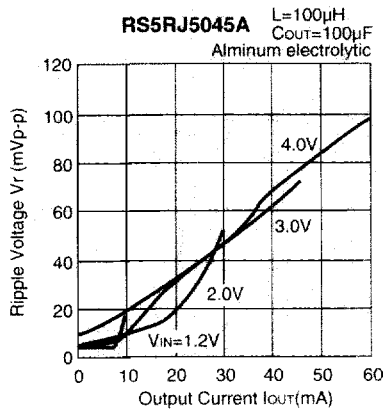
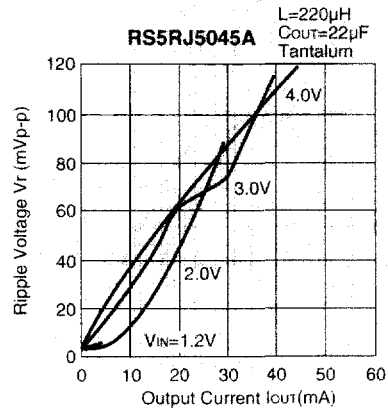
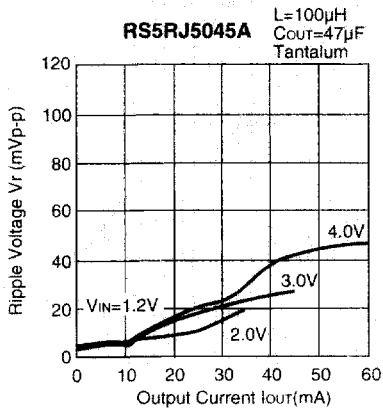
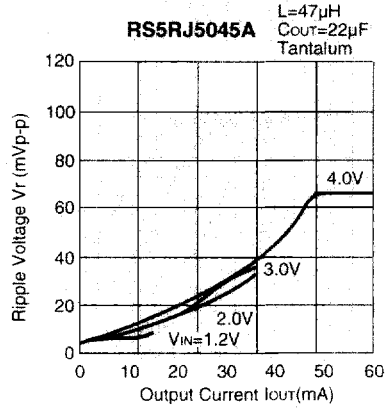
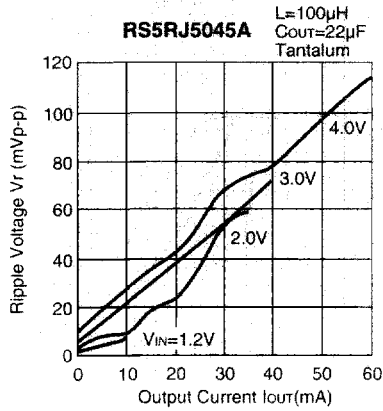

## 4) Efficiency vs. Input Voltage (Topt=25°C)

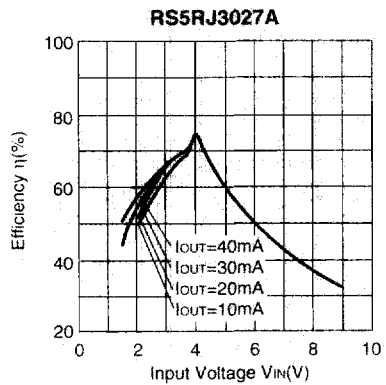
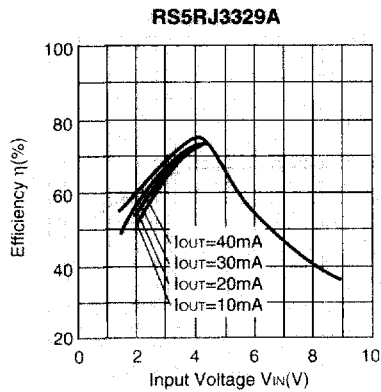
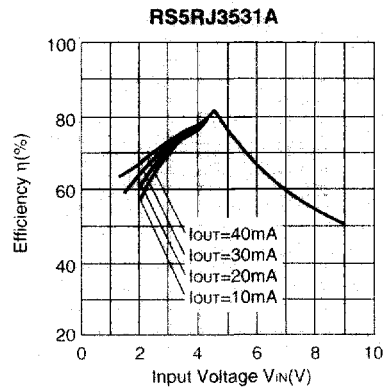
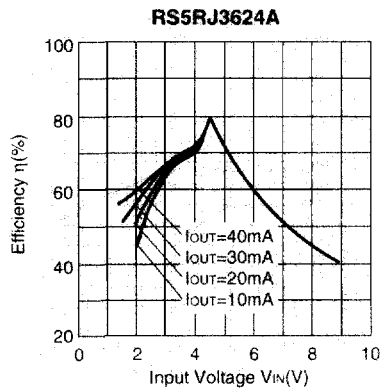
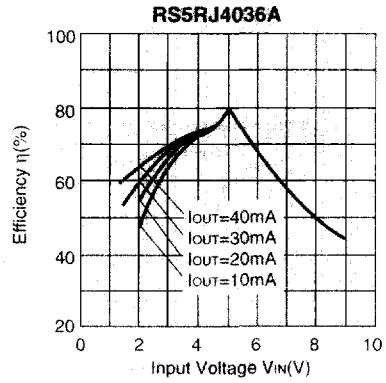
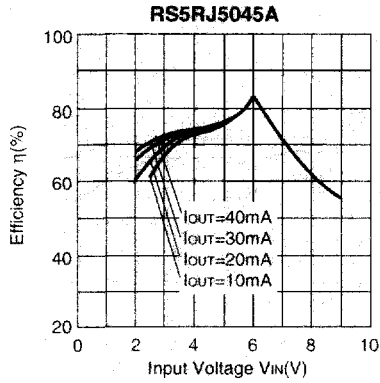

5) Efficiency vs. Output Voltage (Topt=25°C)

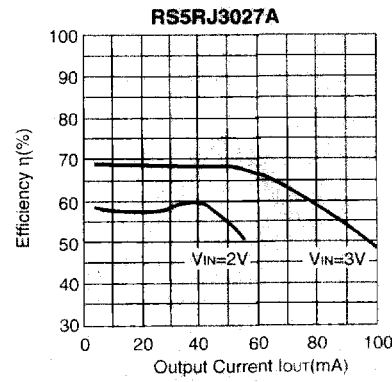
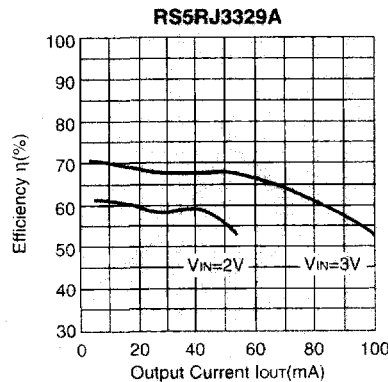
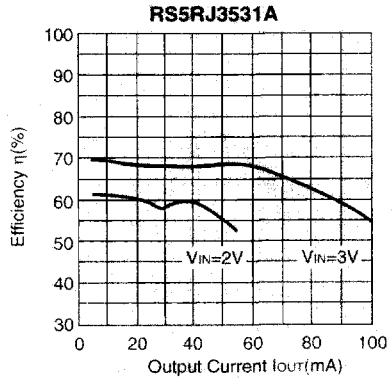
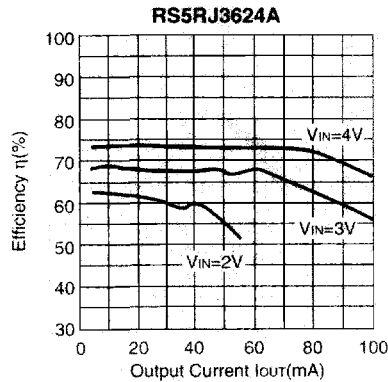
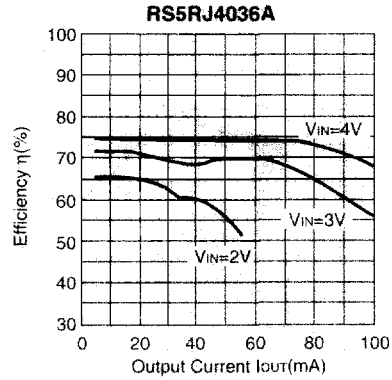
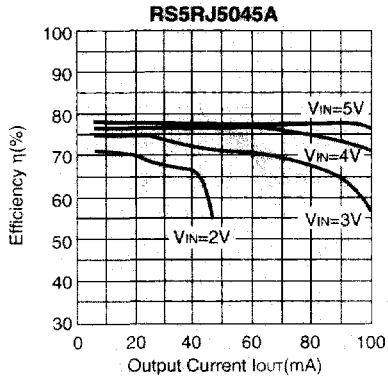



6) Soft Start Time vs. Input Voltage

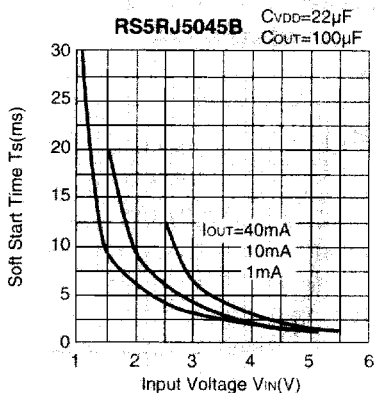
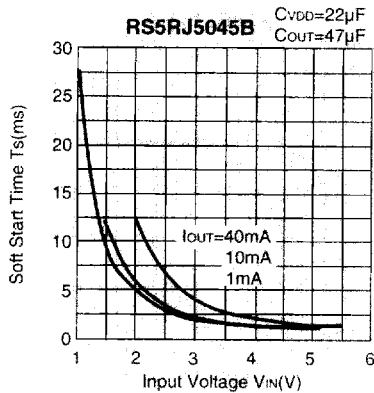
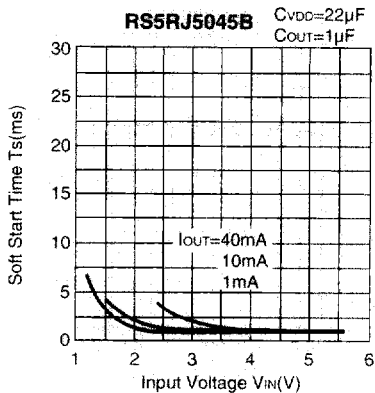

7) Maximum Oscillator Frequency vs. Temperature

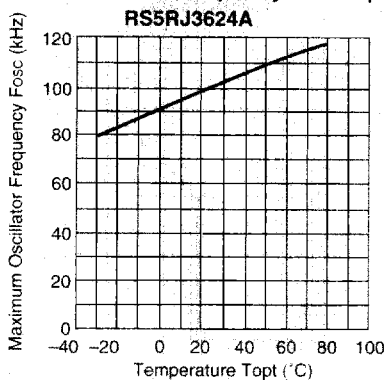

8) Oscillator Duty Cycle vs. Temperature

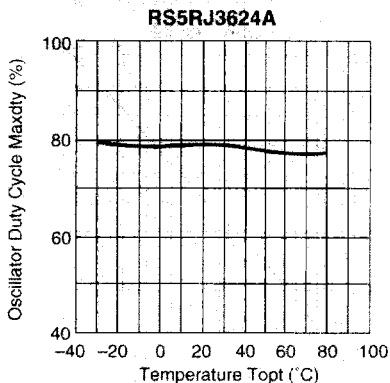

9) Output Voltage ( $V_{DD}$ ) vs. Temperature

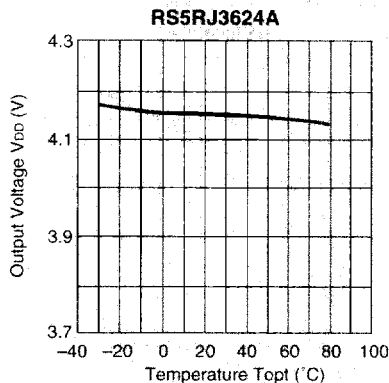

10) Output Voltage vs. Temperature

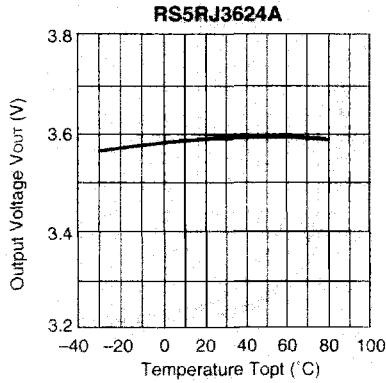

11) Detector Threshold vs. Temperature

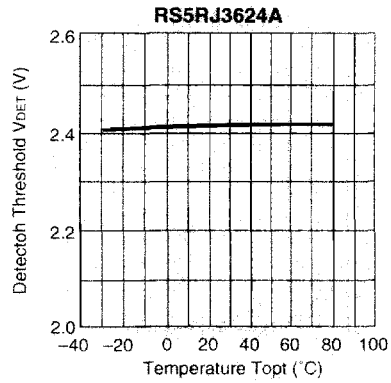

12) VD Output Voltage vs. VD Input Voltage

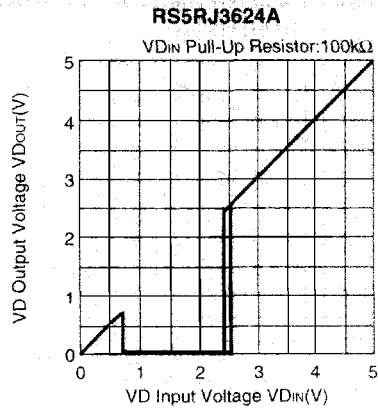

13) Supply Current vs. Input Voltage

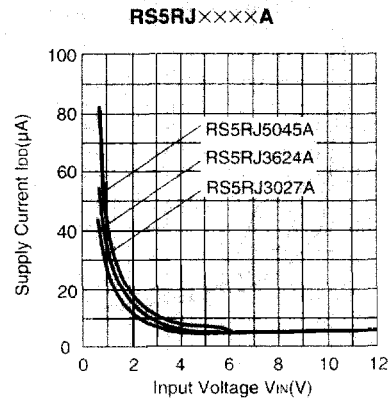

14) Stand-by Current vs. Temperature

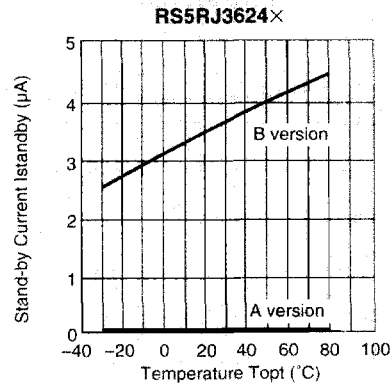

15) VD Input Current vs. VD Input Voltage

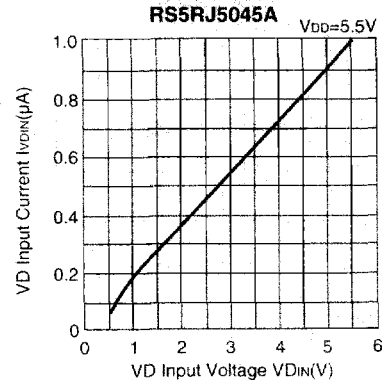

## 16) Start-up/Hold-on Voltage vs. Output Current

RS5RJ5045A

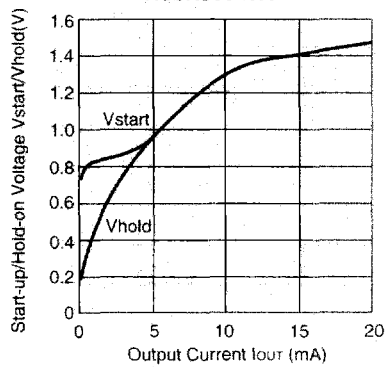

17) Load Transient Response

RS5RJ5045A

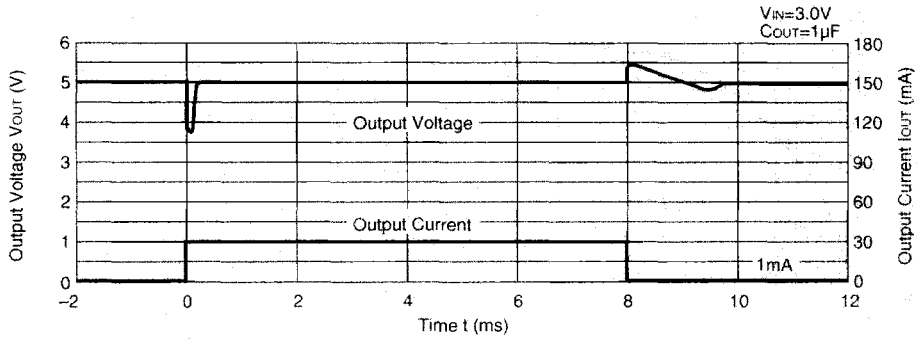

RS5RJ5045A

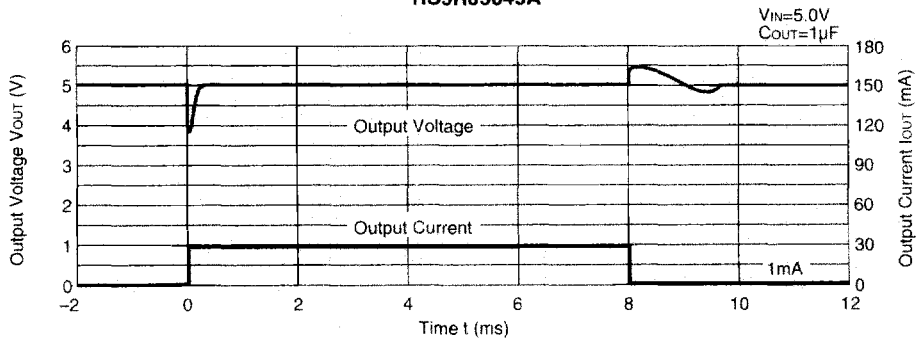

RS5RJ5045A

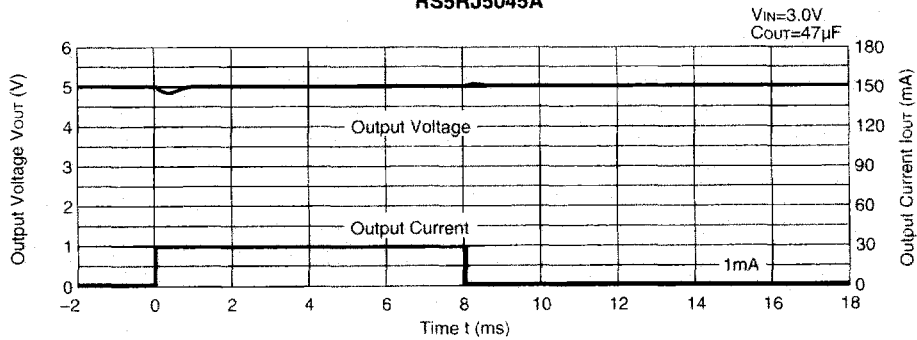

RS5RJ5045A

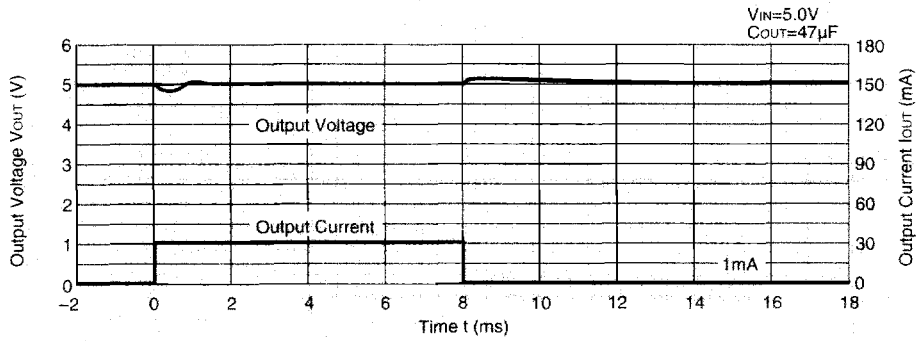

RS5RJ5045A

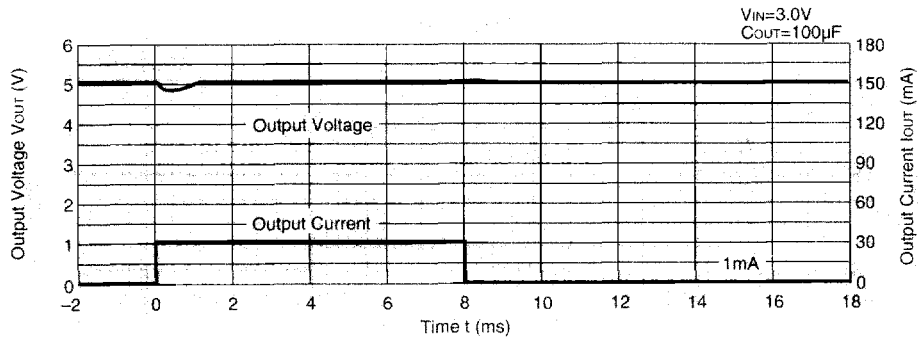

RS5RJ5045A

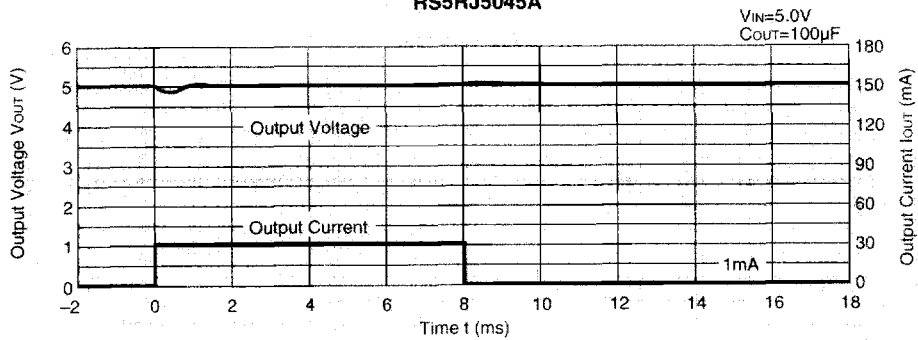

18) Line Transient Response

RS5RJ5045A

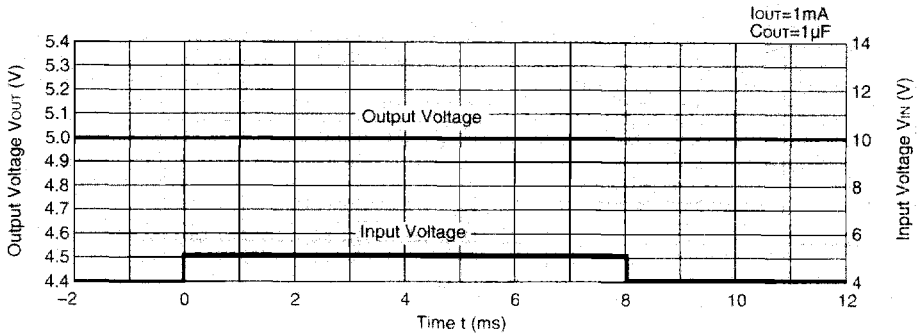

RS5RJ5045A

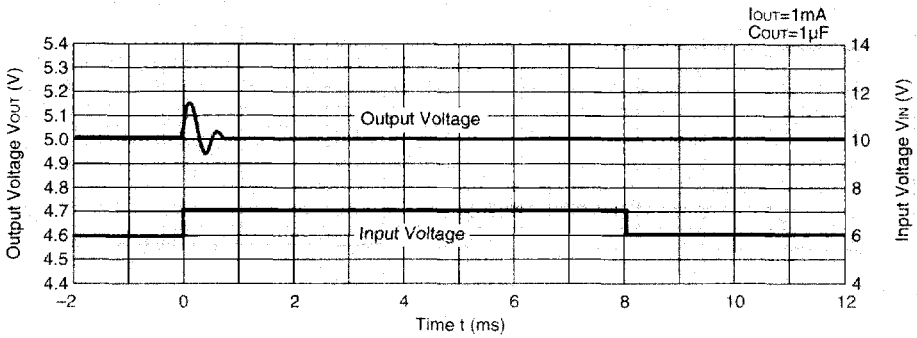

RS5RJ5045A

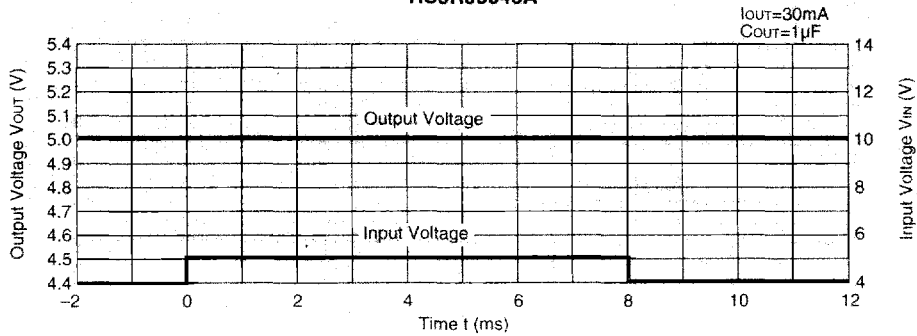

## RS5RJ5045A

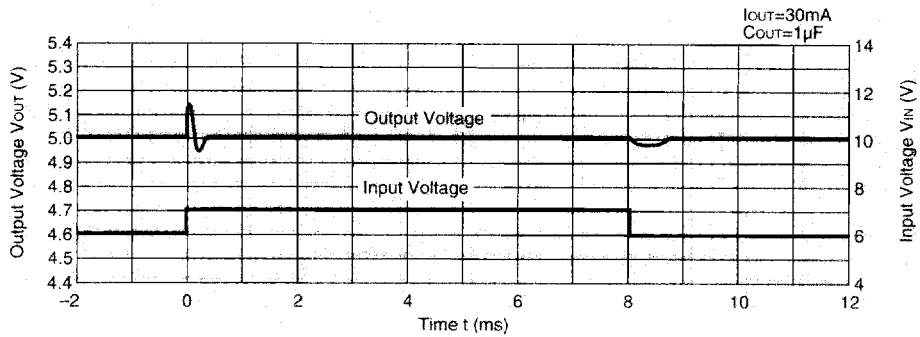

## RS5RJ5045A

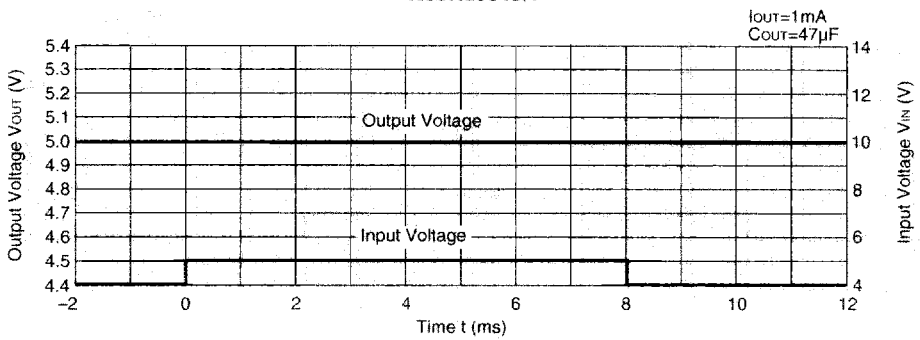

## RS5RJ5045A

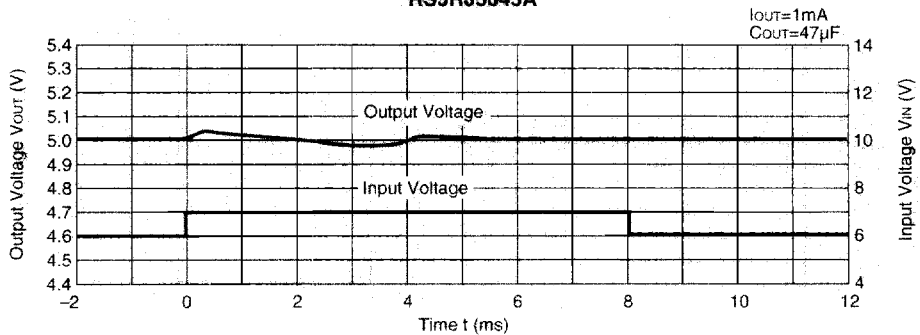

RS5RJ5045A

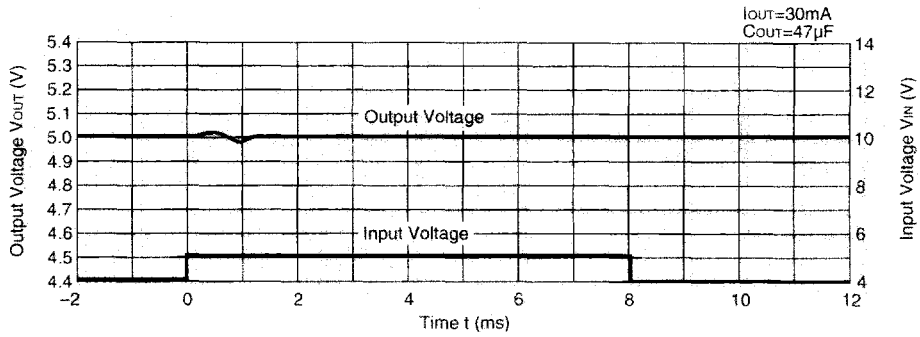

RS5RJ5045A

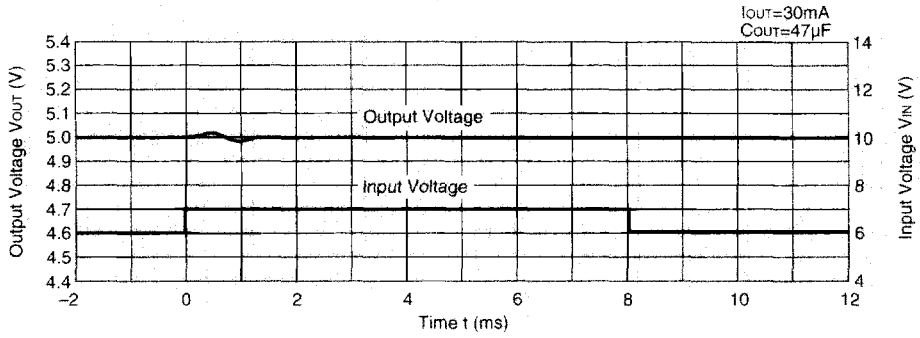

RS5RJ5045A

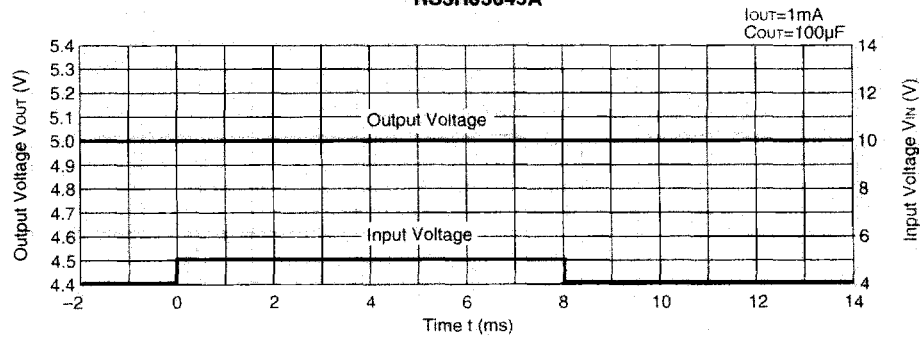



RS5RJ5045A

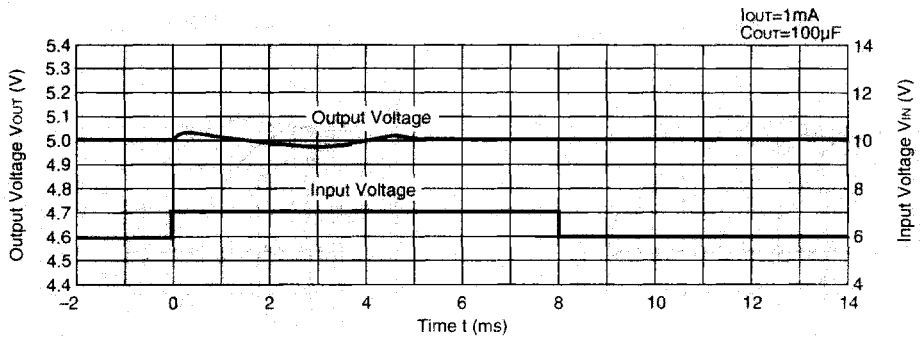

RS5RJ5045A

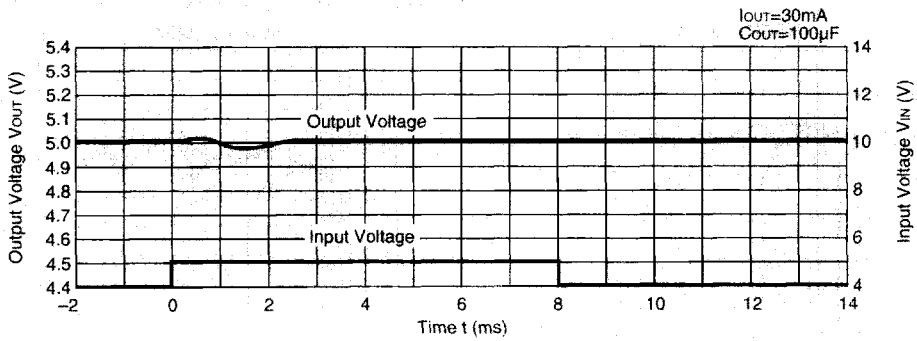

RS5RJ5045A

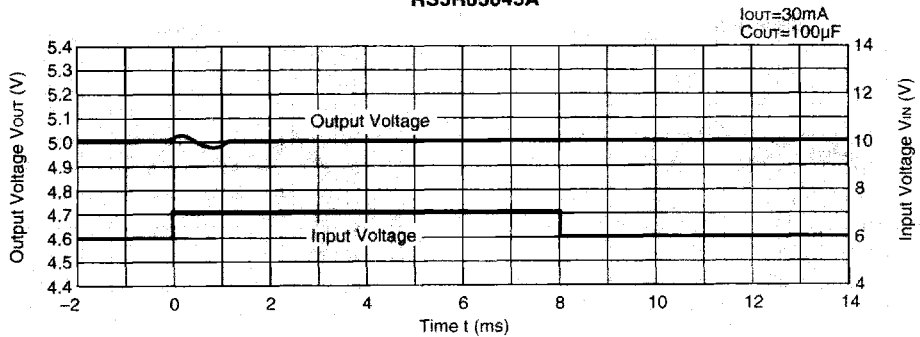

19) Output Voltage vs. V<sub>DD</sub> Output Current

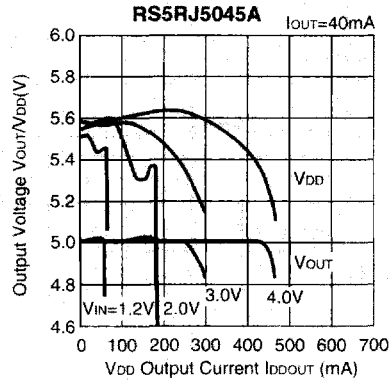
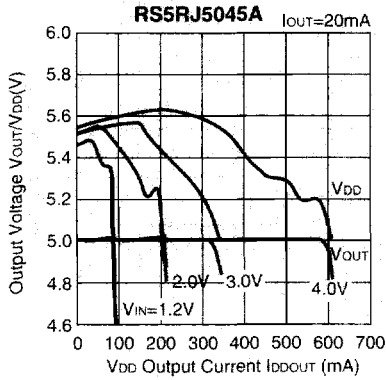

20) Output Current Efficiency vs. V<sub>DD</sub> Output Current

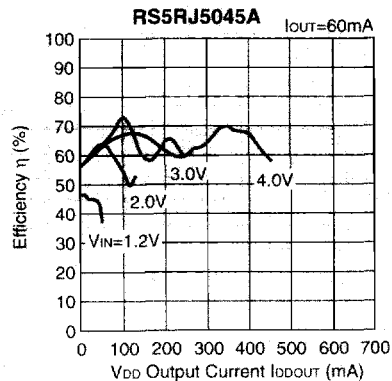
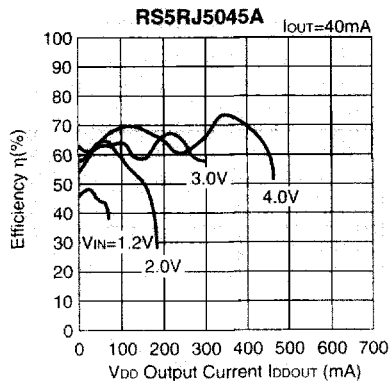
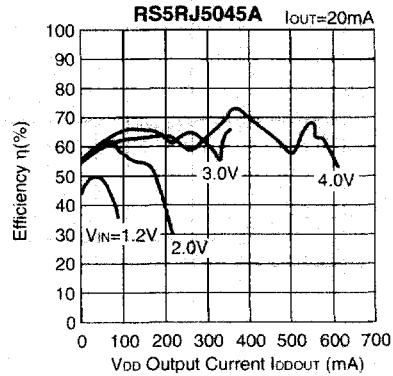
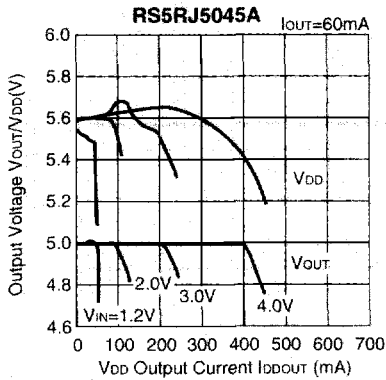

(NOTE) Efficiency  $\eta$  at Typical Characteristics 20) is shown by the following formula:  $\eta = \frac{(V_{DD} \times I_{DDOUT}) + (V_{OUT} \times I_{OUT})}{V_{IN} \times I_{IN}} \times 100$

## BASIC CIRCUIT

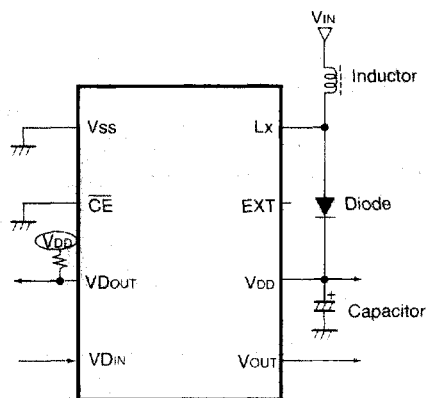

Examples of Parts : Inductor : RCR-664D (100 $\mu$ H) made by Sumida Electric Co., Ltd.

Diode : MA721 (Schottky type) made by Matsushita Electronics Corporation

Capacitor : 22 $\mu$ F (Tantalum type)

## TYPICAL APPLICATIONS

### • Current Boost Circuit 1

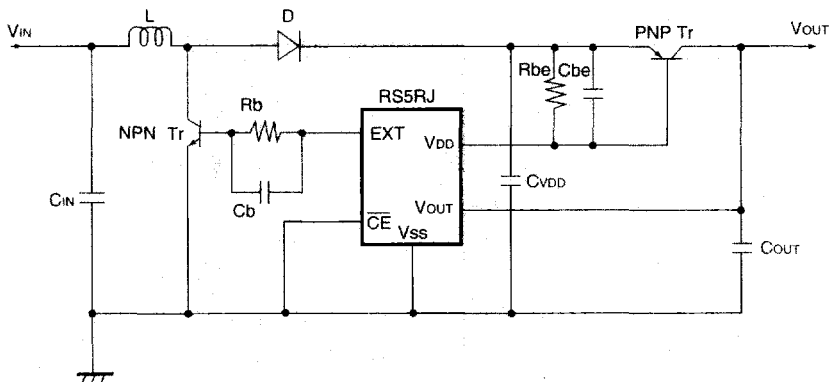

Examples of Components	L	: 47 $\mu$ H(SUMIDA ELECTRIC CD105)	Cd	: 0.01 $\mu$ F
	D	: Schottky Diode (HITACHI HRP22)	Cbe	: 0.1 $\mu$ F(RS5RJ5045 $\times$ , RS5RJ4036 $\times$ , RS5RJ3624 $\times$ )
	CIN	: 220 $\mu$ F(Aluminum electrolytic Type)		100 $\mu$ F(RS5RJ3531 $\times$ , RS5RJ3329 $\times$ , RS5RJ3027 $\times$ )
	CvDD	: 100 $\mu$ F(Tantalum type)/ 220 $\mu$ F(Aluminum electrolytic Type)	NPN Tr	: 2SD1628
	COUT	: 47 $\mu$ F(Tantalum Type)	PNP Tr	: 2SA1213
			Rb	: 220 $\Omega$
		Rbe	: 12 $\Omega$	

### • Current Boost Circuit 2 (High Efficiency Circuit)

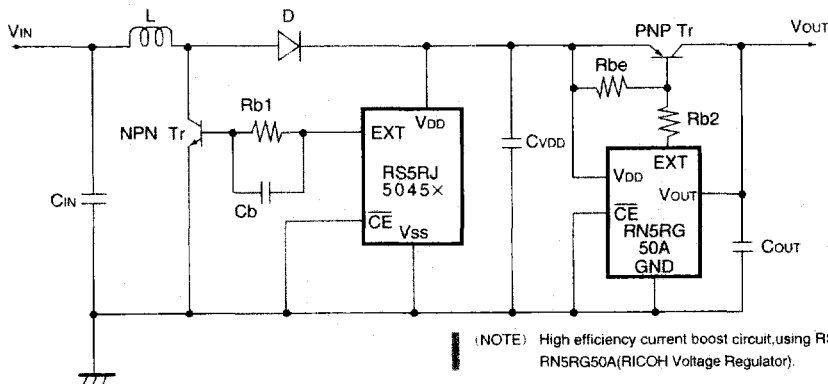

(NOTE) High efficiency current boost circuit, using RS5RJ5045 $\times$  with RN5RG50A(RICOH Voltage Regulator).

Examples of Components	L	: 47 $\mu$ H(SUMIDA ELECTRIC CD105)	Cd	: 0.01 $\mu$ F
	D	: Schottky Diode (HITACHI HRP22)	NPN Tr	: 2SD1628
	CIN	: 33 $\mu$ F(Tantalum type)/ 220 $\mu$ F(Aluminum electrolytic Type)	PNP Tr	: 2SA1213
	CvDD	: 33 $\mu$ F(Tantalum type)/ 220 $\mu$ F(Aluminum electrolytic Type)	Rb1	: 220 $\Omega$
	COUT	: 47 $\mu$ F(Tantalum Type)	Rb2	: 330 $\Omega$
			Rbe	: 10k $\Omega$

## APPLICATION HINTS

When using these ICs, be sure to take care of the following points:

- Set external components as close as possible to the IC and minimize the connection between the components and the IC. In particular, when an external component is connected to V<sub>OUT</sub> Pin, make minimum connection with the capacitor.
- Make sufficient grounding. A large current flows through V<sub>SS</sub> Pin by switching. When the impedance of the V<sub>SS</sub> connection is high, the potential within the IC is varied by the switching current. This may result in unstable operation of the IC.
- Use capacitor with a capacity of 10 $\mu$ F or more, and with good high frequency characteristics such as tantalum capacitor. We recommend the use of a capacitor with an allowable voltage which is at least three times the output set voltage. This is because there may be the case where a spike-shaped high voltage is generated by the inductor when L<sub>x</sub> transistor is turned OFF.
- Take the utmost care when choosing an inductor. Namely, choose such an inductor that has sufficiently small d.c. resistance and large allowable current, and hardly reaches magnetic saturation. When the inductance value of the inductor is small, there may be the case where I<sub>LX</sub> exceeds the absolute maximum ratings at the maximum load. Use an inductor with an appropriate inductance.
- Use a diode of a Schottky type with high switching speed, and also take care of the rated current.

The performance of power source circuits using these ICs largely depends upon the peripheral circuits. Take the utmost care in the selection of the peripheral circuits. In particular, design the peripheral circuits in such a manner that the values such as voltage, current and power of each component, PCB patterns and the IC do not exceed their respective rated values.