

# SHIELDED SMD FERRITE WIRE WOUND INDUCTOR

AISC-1008S-xxx



**RoHS**  
Compliant



2.54 x 2.11 x 2.74mm

## FEATURES:

- High Inductance Value & Electrical Strength
- Magnetic shielding & excellent thermal stability
- High reliability & easy surface mount assembly

## APPLICATIONS:

- Excellent for power line DC/DC conversion applications
- Used in hard disk, notebook computer and other electronic equipment

## STANDARD SPECIFICATIONS:

### PARAMETERS

ABRACON P/N:	AISC-1008S-xxx Series
Operating temperature:	-25°C to + 125°C
Storage temperature:	-25°C to + 85°C, 70% RH max.

Part Number AISC-1008(L)-	L (μH)	L Test Freq (KHz)	Tolerance (±20%)	Q Min	Q Test Freq (MHz)	SRF Min (MHz)	R <sub>DC</sub> Max (Ω)	I <sub>DC</sub> Max (mA)
1R0M	1.0	100	M	35	1	350	0.05	2000
1R5M	1.5	100	M	35	1	260	0.06	2000
1R8M	1.8	100	M	35	1	230	0.09	1900
2R7M	2.7	100	M	38	1	190	0.14	1600
3R9M	3.9	100	M	38	1	175	0.26	1200
4R7M	4.7	100	M	38	1	160	0.35	1100
5R6M	5.6	100	M	38	1	150	0.40	900
6R8M	6.8	100	M	38	1	120	0.60	800
100M	10	100	M	38	1	105	0.95	720
150M	15	100	M	38	1	40	1.15	600
220M	22	100	M	40	1	26	1.40	550
330M	33	100	M	45	1	20	1.60	500
390M	39	100	M	45	1	16	1.85	470
470M	47	100	M	45	1	19	2.50	420
680M	68	100	M	45	1	12	3.80	300
820M	82	100	M	45	1	9.0	4.20	300
101M	100	100	M	45	1	7.0	5.80	280
121M	120	100	M	50	1	7.0	6.20	250
151M	150	100	M	50	1	5.8	7.50	220
221M	220	100	M	55	1	10.0	10.0	210
331M	330	100	M	55	1	3.8	11.5	190
471M	470	100	M	55	1	3.1	16.5	180
561M	560	100	M	55	1	2.8	18.0	150
681M	680	100	M	55	1	2.5	24.0	140
821M	820	100	M	45	1	1.5	26.0	120
102M	1000	100	M	45	1	2.0	30.0	110

## OPTIONS AND PART IDENTIFICATION:

(Left blank if standard)

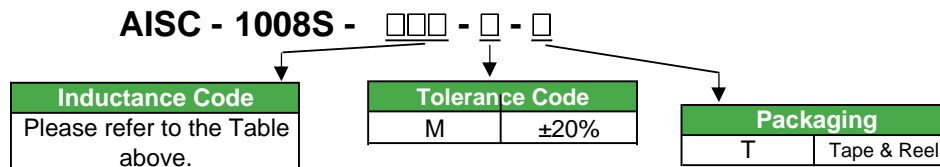

# SHIELDED SMD FERRITE WIRE WOUND INDUCTOR

AISC-1008S-xxx



RoHS  
Compliant



2.54 x 2.11 x 2.74mm

## OUTLINE DRAWING:

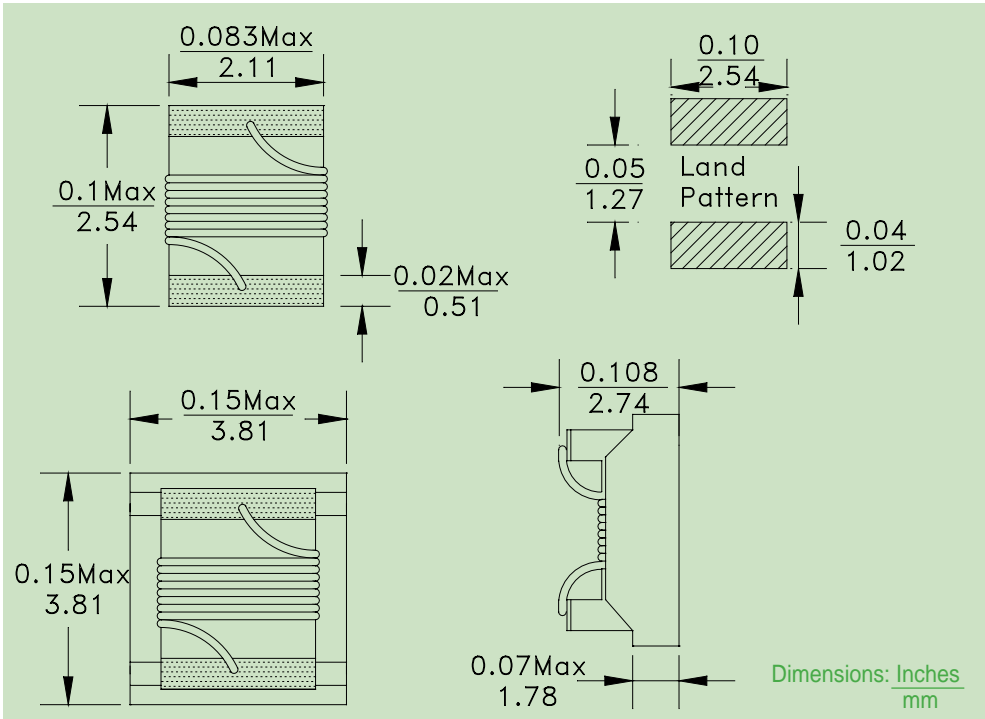

## TAPE & REEL: Tape and reel 750pcs/reel

### Dimensions of Tape

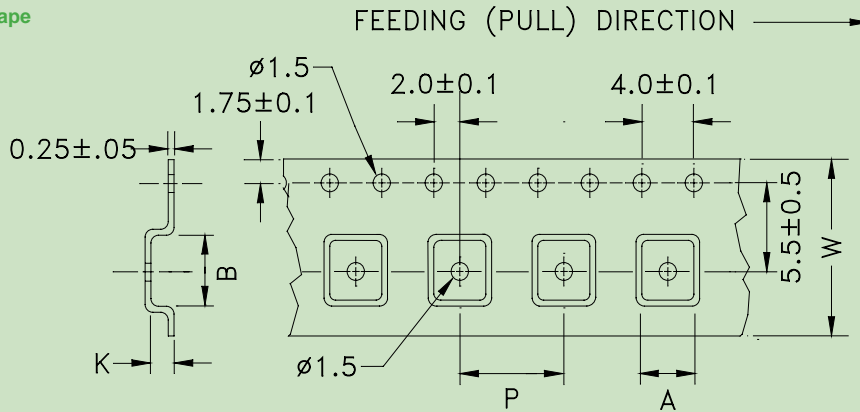

ABRACON P/N	A (mm)	B (mm)	K (mm)	P (mm)	W (mm)	PCS/REEL
AISC-1008S	3.85	3.85	2.85	8	12	750

### Dimensions of Reel

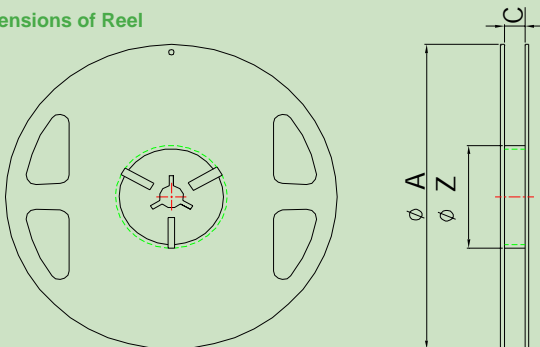

series	A	C	Z
AISC-1008S	178±2.0	12.0+1.5	60±1.0

Dimensions: mm

ABRACON IS  
ISO 9001 / QS 9000  
CERTIFIED



Visit [www.abracon.com](http://www.abracon.com) for Terms & Conditions of Sale **Revised: 11.15.07**  
30332 Esperanza, Rancho Santa Margarita, California 92688  
tel 949-546-8000 | fax 949-546-8001 | [www.abracon.com](http://www.abracon.com)