



# CV111-3A

## UMTS-band High Linearity Downconverter

The Communications Edge™

Product Information

### Product Features

- High dynamic range downconverter with integrated LO, IF, & RF amps
- RF: 1900 – 2200 MHz
- IF: 65 – 300 MHz
- +38 dBm Output IP3
- +21 dBm Output P1dB
- 5.3 dB Noise Figure
- +5V Single supply operation
- Pb-free 6mm 28-pin QFN package
- Low-side LO configuration
- Common footprint with other PCS/ cellular versions

### Product Description

The CV111-3A is a high linearity downconverter designed to meet the demanding issues for performance, functionality, and cost goals of current and next generation mobile infrastructure basestations. It provides high dynamic range performance in a low profile surface-mount leadless package that measures 6 x 6 mm square.

Functionality includes RF amplification, frequency conversion and IF amplification, while an integrated LO driver amplifier powers the passive mixer. The MCM is implemented with reliable and mature GaAs MESFET and InGaP HBT technology.

Typical applications include frequency down conversion, modulation and demodulation for receivers used in CDMA, CDMA2000, W-CDMA / IMT2000, GPRS, and EDGE 2.5G mobile infrastructure technologies for UMTS frequency bands.

### Functional Diagram

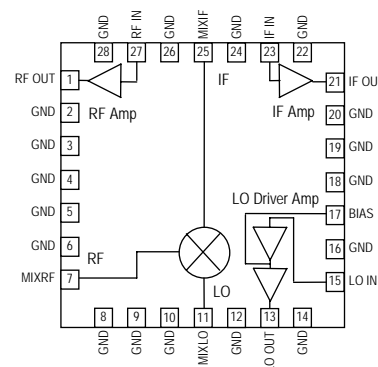

Top View

### Specifications <sup>(1)</sup>

Parameters	Units	Min	Typ	Max	Comments
RF Frequency Range	MHz		1900 – 2200		
LO Frequency Range	MHz		1600 – 2135		
IF Center Frequency Range	MHz		65 – 300		See note 2
% Bandwidth around IF center frequency	%		±7.5		See note 3
IF Test Frequency	MHz		240		
SSB Conversion Gain	dB		20		Temp = 25 °C
Gain Drift over Temp (-40 to 85 °C)	dB		±0.5		Referenced to +25 °C
Output IP3	dBm		+38		See note 4
Output IP2	dBm		+48		See note 4
Output 1dB Compression Point	dBm		+21		
Noise Figure	dB		5.3		See note 5
LO Input Drive Level	dBm	-2.5	0	+2.5	
LO-RF Isolation	dB		40		P <sub>LO</sub> = 0 dBm
LO-IF Isolation	dB		25		P <sub>LO</sub> = 0 dBm
Return Loss: RF Port	dB		14		
Return Loss: LO Port	dB		14		
Return Loss: IF Port	dB		14		
Operating Supply Voltage	V	+4.9	+5	+5.1	
Supply Current	mA	290	360	480	
FIT Rating	failures / 1E9 hrs			72.1	@ 70° C ambient, 90% confidence
Junction Temperature	°C			160	See note 6

1. Specifications when using the application specific circuit (shown on page 3) with a low side LO = 0 dBm in a downconverting application over the operating case temperature range.  
 2. IF matching components affect the center IF frequency. Proper component values for other IF center frequencies than shown can be provided by emailing to applications.engineering@wj.com.  
 3. The IF bandwidth of the converter is defined as 15% around any center frequency in its operating IF frequency range. The bandwidth is determined with external components. Specifications are valid around the total ±7.5% bandwidth. i.e. with a center frequency of 80 MHz, the specifications are valid from 80 ± 6 MHz.  
 4. Assumes the supply voltage = +5 V. OIP3 is measured with Δf = 1 MHz with IF<sub>test</sub> = 5 dBm / tone.  
 5. Assumes LO injection noise is filtered at the thermal noise floor, -174 dBm/Hz, at the RF, IF, and Image frequencies.  
 6. The maximum junction temperature ensures a minimum MTTF rating of 1 million hours of usage.

### Absolute Maximum Rating

Parameter	Rating
Operating Case Temperature	-40 to +85° C
Storage Temperature	-55 to +125° C
DC Voltage	+6 V
Junction Temperature	+220 °C
RF Input (continuous)	+2 dBm

Operation of this device above any of these parameters may cause permanent damage.

### Ordering Information

Part No.	Description
CV111-3AF	UMTS-band High Linearity Downconverter (lead-free/RoHS-compliant 6x6mm QFN package)
CV111-3APCB75	Fully Assembled Eval. Board, IF = 75MHz
CV111-3APCB240	Fully Assembled Eval. Board, IF = 240MHz

Specifications and information are subject to change without notice



# CV111-3A

## UMTS-band High Linearity Downconverter

The Communications Edge™

Product Information

### Device Architecture / Application Circuit Information

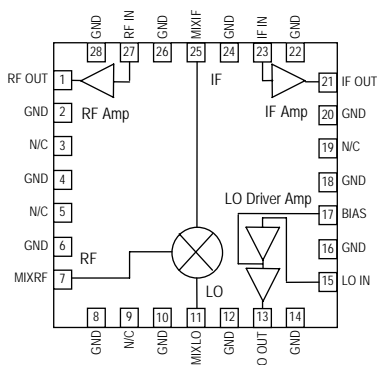

Typical Downconverter Performance Chain Analysis

Stage	Gain (dB)	Output P1dB (dBm)	Output IP3 (dBm)	NF (dB)	Current (mA)	Cumulative Performance				
						Gain (dB)	Output P1dB (dBm)	Output IP3 (dBm)	NF (dB)	
RF Amplifier	12	21	41	3.5	140	12	21.0	41.0	3.5	
RF Filter	-2	---	---	2.0	---	10	19.0	39.0	3.6	
LO Amp / MMIC Mixer	-8.5	8	23	9.1	80	1.5	6.1	22.2	4.8	
IF Amplifier	18.5	23	41	2.1	140	20	20.7	37.9	5.4	
<b>CV111-3A</b>	<b>Cumulative Performance</b>					<b>360</b>	<b>20</b>	<b>20.7</b>	<b>37.9</b>	<b>5.4</b>

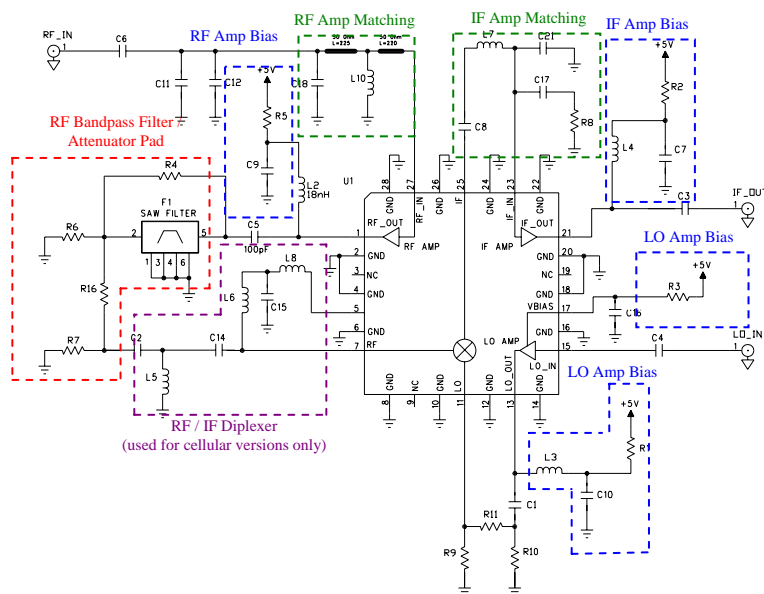

Printed Circuit Board Material:  
.014" FR-4, 4 layers, .062" total thickness

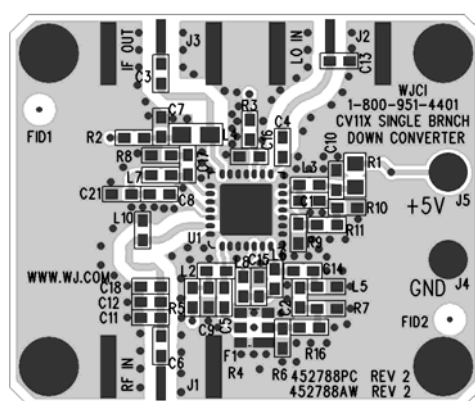

**CV111-3A:** The application circuit can be broken up into four main functions as denoted in the colored dotted areas above: RF/IF diplexing (purple; this is only used with the cellular-band CV products), amplifier matching (green), filtering (red), and dc biasing (blue). There are various placeholders for chip components in the circuit schematic so that a common PCB can be used for all WJ single-branch converters. Additional placeholders for other optional functions such as filtering are also included.

**RF / IF Amplifier Matching:** The RF amplifier requires a shunt matching element for optimal gain and input return loss performance. The IF amplifier requires matching elements to optimize the performance of the amplifier to the desired IF center frequency. Since IF bandwidths are typically on the order of 5 to 10%, a simple two element matching network, in the form of either a high-pass or low-pass filter structure, is sufficient to match the MMIC IF amplifier over these narrow bandwidths. Proper component values for other IF center frequencies can be provided by emailing to [applications.engineering@wj.com](mailto:applications.engineering@wj.com).

**RF Bandpass Filtering:** Bandpass filtering is recommended to achieve the best noise figure performance with the downconverter. The bandpass filter, implemented with a SAW filter on the application circuit, allows for the suppression of noise from the image frequency. It is permissible to not use a filter and use a 2 dB pad with R6, R7, and R16 instead with slightly degraded noise figure performance.

**External Diplexer:** This is only used with the cellular-band CV products. The mixer performs the diplexing internally for the CV111-3A; therefore the components shown in the diplexer section should be loaded as follows: C2 = C14 = 0 Ω.

**DC biasing:** DC bias must be provided for the RF, LO and IF amplifiers in the converter. R1 sets the operating current for the last stage of the LO amplifier and is chosen to optimize the mixer LO drive level. Proper RF chokes and bypass capacitors are chosen for proper amplifier biasing at the intended frequency of operation. The "+5 V" dc bias should be supplied directly from a voltage regulator.



# CV111-3A

UMTS-band High Linearity Downconverter

The Communications Edge™

Product Information

## Downconverting Application Circuit: CV111-3APCB75

RF = 1900 – 2200 MHz, IF = 75 MHz

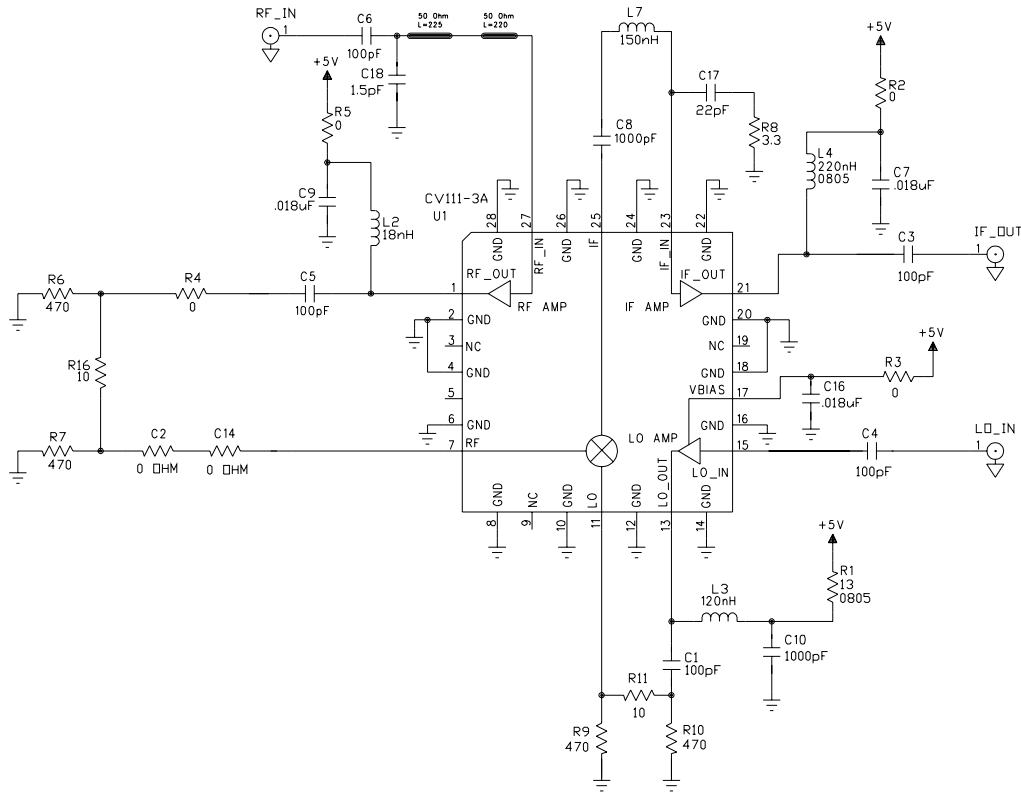

### PCB Layout

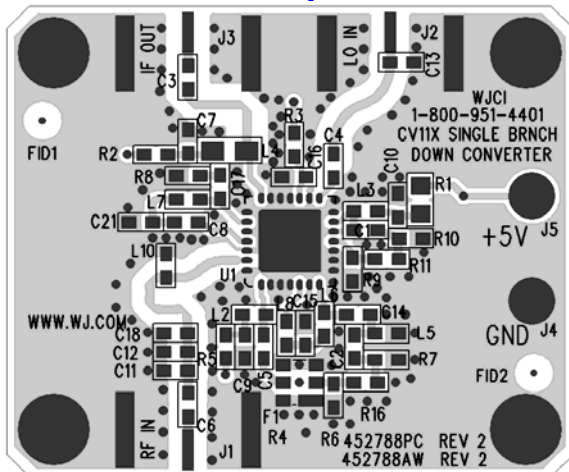

Circuit Board Material: .014" FR-4, 4 layers, .062" total thickness

### Bill of Materials

Ref. Desig.	Component
R1	13 Ω chip resistor, size 0805
R2, R3, R4, R5, C2, C14	0 Ω chip resistor
R6, R7, R9, R10	470 Ω chip resistor
R8	3.3 Ω chip resistor
R11, R16	10 Ω chip resistor
C1, C3, C4, C5, C6	100 pF chip capacitor
C7, C9, C16	0.018 μF chip capacitor
C8, C10	1000 pF chip capacitor
C11, C12, C13, C15, C21, F1, L5, L6, L8, L10	Shown in silkscreen, but not used in actual circuit.
C17	22 pF chip capacitor
C18	1.5 pF chip capacitor
L2	18 nH chip inductor
L3	120 nH chip inductor
L4	220 nH chip inductor, size 0805
L7	22 nH chip inductor
U1	CV111-3A WJ Converter

All components are of size 0603 unless otherwise specified.



# CV111-3A

UMTS-band High Linearity Downconverter

The Communications Edge™

Product Information

## Downconverting Application Circuit: CV111-3APCB240

RF = 1900 – 2200 MHz, IF = 240 MHz

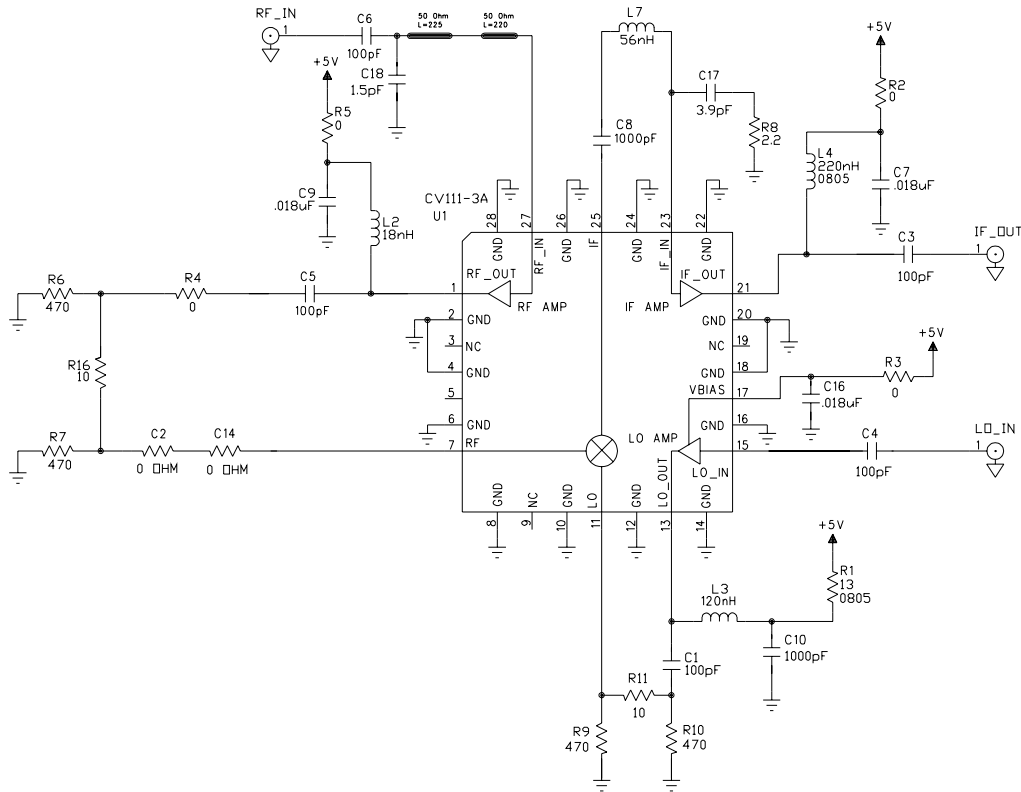

### PCB Layout

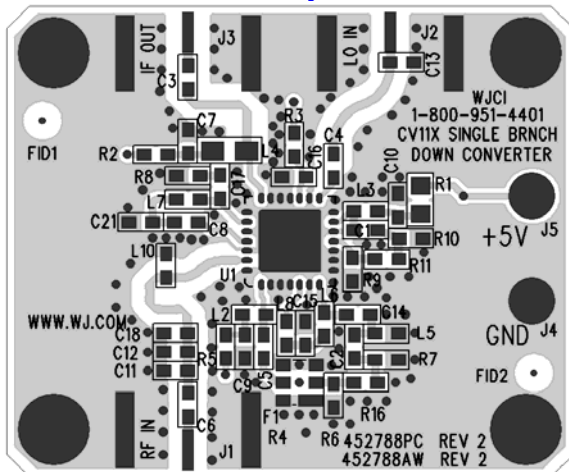

Circuit Board Material: .014" FR-4, 4 layers, .062" total thickness

### Bill of Materials

Ref. Desig.	Component
R1	13 Ω chip resistor, size 0805
R2, R3, R4, R5, C2, C14	0 Ω chip resistor
R6, R7, R9, R10	470 Ω chip resistor
R8	2.2 Ω chip resistor
R11, R16	10 Ω chip resistor
C1, C3, C4, C5, C6	100 pF chip capacitor
C7, C9, C16	0.018 μF chip capacitor
C8, C10	1000 pF chip capacitor
C11, C12, C13, C15, C21, F1, L5, L6, L8, L10	Shown in silkscreen, but not used in actual circuit.
C17	3.9 pF chip capacitor
C18	1.5 pF chip capacitor
L2	18 nH chip inductor
L3	120 nH chip inductor
L4	220 nH chip inductor, size 0805
L7	56 nH chip inductor
U1	CV111-3A WJ Converter

All components are of size 0603 unless otherwise specified.



# CV111-3A

UMTS-band High Linearity Downconverter

The Communications Edge™

Product Information

## CV111-3AF Mechanical Information

This package is lead-free/RoHS-compliant. The plating material on the pins is annealed matte tin over copper. It is compatible with both lead-free (maximum 260°C reflow temperature) and leaded (maximum 245°C reflow temperature) soldering processes.

### Outline Drawing

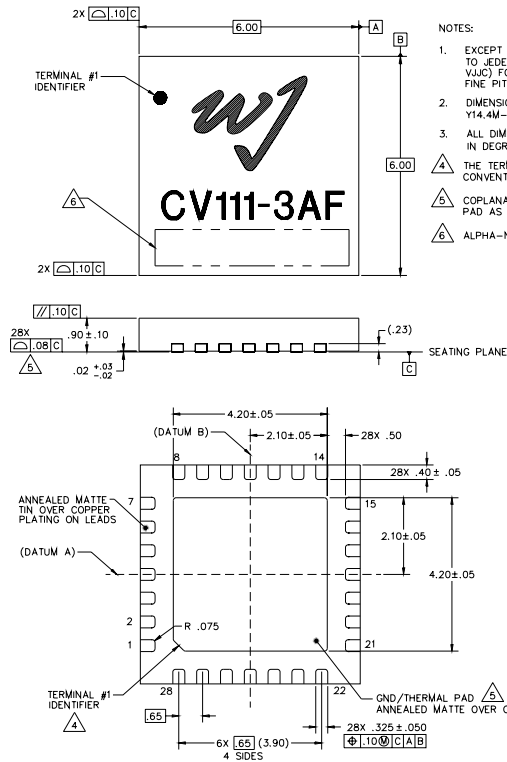

### Product Marking

The component will be lasermarked with a "CV111-3AF" product label with an alphanumeric lot code on the top surface of the package.

Tape and reel specifications for this part will be located on the website in the "Application Notes" section.

### ESD / MSL Information



Caution! ESD sensitive device.

ESD Rating: Class 1B

Value: Passes  $\geq 500V$  to  $<1000V$

Test: Human Body Model (HBM)

Standard: JEDEC Standard JESD22-A114

ESD Rating: Class III

Value: Passes  $\geq 500V$  to  $<1000V$

Test: Charged Device Model (CDM)

Standard: JEDEC Standard JESD22-C101

MSL Rating: Level 2 at +260°C convection reflow

Standard: JEDEC Standard J-STD-020

### Mounting Configuration / Land Pattern

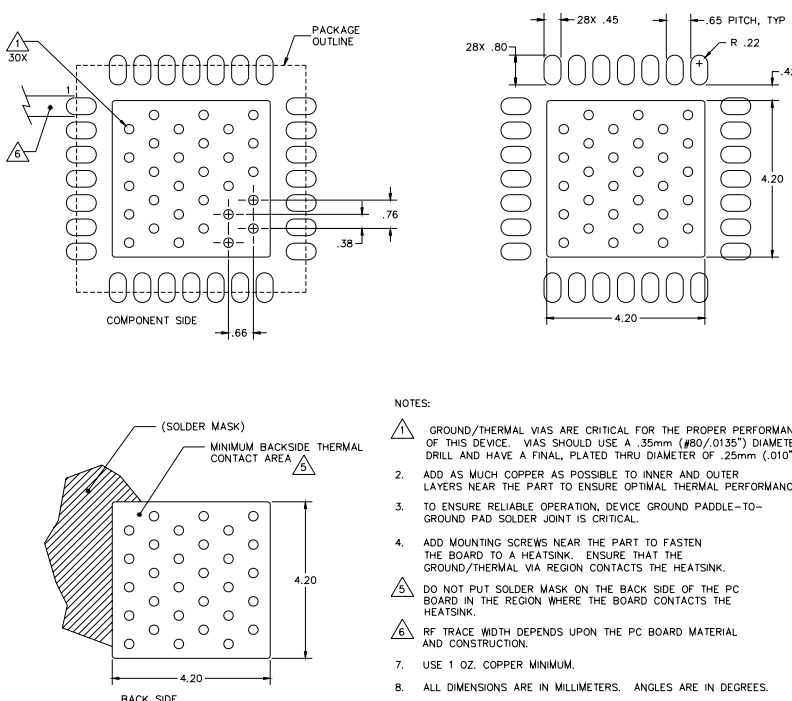

### Functional Pin Layout

Pin	Function	Pin	Function
1	RF Amp Output	15	LO Amp Input
2	GND	16	GND
3	N/C or GND	17	LO Amp Bias
4	GND	18	GND
5	N/C or GND	19	N/C or GND
6	GND	20	GND
7	Mixer RF Input	21	IF Amp Output/Bias
8	GND	22	GND
9	N/C or GND	23	IF Amp Input
10	GND	24	GND
11	Mixer LO Input	25	Mixer IF Output
12	GND	26	GND
13	LO Amp Output/Bias	27	RF Amp Input
14	GND	28	GND

Specifications and information are subject to change without notice