



# MIC2782

## Dual-Input Push Button Reset IC with Immediate and Delayed Outputs

### General Description

The MIC2782 is a two input, two output push button reset IC. It will generate a reset pulse for a factory programmed reset timeout period after both manual reset inputs have been held to a logic-low for the factory programmed setup period. The MIC2782 also has an ANDOUT logic output which will activate if both inputs are held low for longer than a debounce time (1.5ms), and deactivate if one or both inputs are released for longer than a debounce time (1.5ms). The RESET and ANDOUT outputs are active-low, open-drain NMOS outputs.

The MIC2782 operates over the 1.5V to 5.5V supply voltage range, consuming 2.2µA of supply current at 3.3V. The device features 65kΩ internal pull-up resistors on both of the inputs (/MR1 and /MR2). The device offers factory programmed setup periods of 6s, 8s, 10s, or 12s and reset timeout periods of 0.5s, 1s or 2s. It is available in a space saving, 6-bump, 0.4mm pitch, 0.8mm x 1.2mm Wafer Level Chip Scale Package.

Data sheets and support documentation can be found on Micrel's web site at: [www.micrel.com](http://www.micrel.com).

### Features

- 1.5V to 5.5V Operating Supply Voltage Range
- 2.2µA Supply Current with /MR1, /MR2 not asserted
- Factory programmed setup periods of 6s, 8s, 10s or 12s
- Factory programmed reset timeout periods of 0.5s, 1s or 2s
- Integrated 65kΩ /MR1 and /MR2 Pull-Up Resistors
- Supports single push button reset with /MR1 tied to /MR2
- RESET asserts after /MR1 and /MR2 are asserted low for a setup period
- ANDOUT asserts after /MR1 and /MR2 are asserted low for a debounce time (1.5ms)
- Open-Drain RESET and ANDOUT Outputs
- 6-bump, 0.4mm pitch, 0.8mm x 1.2mm Wafer Level Chip Scale Package (WLCSP)

### Applications

- Smart Phones
- Tablets
- eBooks
- Portable Games
- Portable Navigation Device

### Typical Application

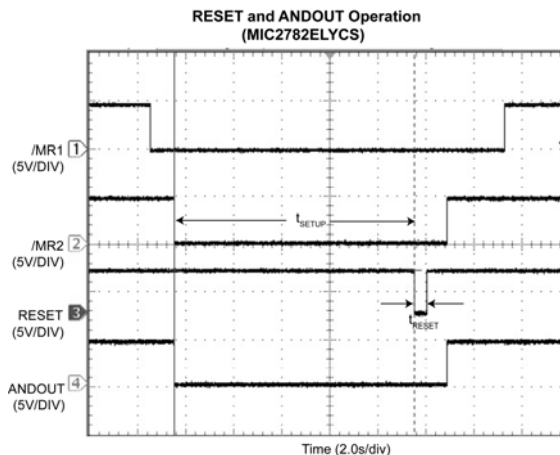
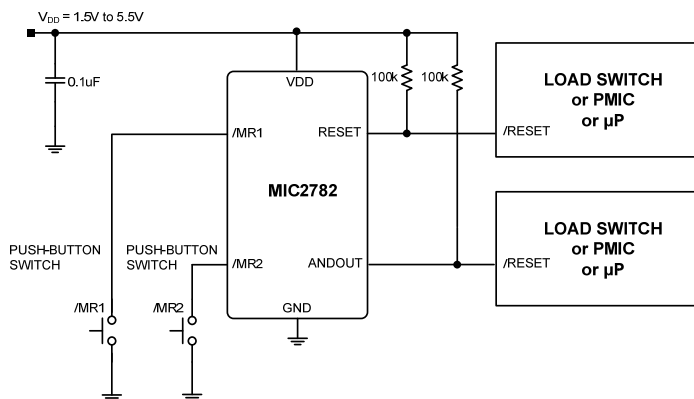

### Ordering Information

Part Number	Part Marking	Setup Period (t <sub>SETUP</sub> ) (s)	Reset Timeout Period (t <sub>RESET</sub> ) (s)	Package
MIC2782CLYCS <sup>(1)</sup>	-	6	0.5	6-bump, 0.4mm pitch, 0.8mm x 1.2mm WLCSP
MIC2782CMYCS <sup>(1)</sup>	-	6	1	6-bump, 0.4mm pitch, 0.8mm x 1.2mm WLCSP
MIC2782CRYCS <sup>(1)</sup>	-	6	2	6-bump, 0.4mm pitch, 0.8mm x 1.2mm WLCSP
MIC2782DLYCS	UKU	8	0.5	6-bump, 0.4mm pitch, 0.8mm x 1.2mm WLCSP
MIC2782DMYCS <sup>(1)</sup>	-	8	1	6-bump, 0.4mm pitch, 0.8mm x 1.2mm WLCSP
MIC2782DRYCS <sup>(1)</sup>	-	8	2	6-bump, 0.4mm pitch, 0.8mm x 1.2mm WLCSP
MIC2782ELYCS	UKW	10	0.5	6-bump, 0.4mm pitch, 0.8mm x 1.2mm WLCSP
MIC2782EMYCS <sup>(1)</sup>	-	10	1	6-bump, 0.4mm pitch, 0.8mm x 1.2mm WLCSP
MIC2782ERYCS <sup>(1)</sup>	-	10	2	6-bump, 0.4mm pitch, 0.8mm x 1.2mm WLCSP
MIC2782FLYCS <sup>(1)</sup>	-	12	0.5	6-bump, 0.4mm pitch, 0.8mm x 1.2mm WLCSP
MIC2782FMYCS <sup>(1)</sup>	-	12	1	6-bump, 0.4mm pitch, 0.8mm x 1.2mm WLCSP
MIC2782FRYCS <sup>(1)</sup>	-	12	2	6-bump, 0.4mm pitch, 0.8mm x 1.2mm WLCSP

**Notes:**

- 1. Contact Factory for availability.

### Ordering Guide

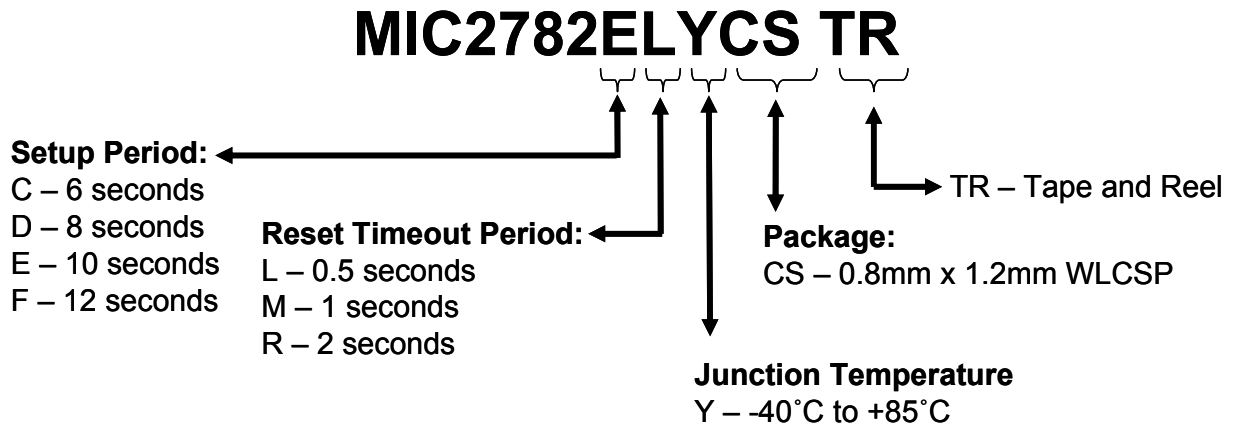

### Chip Scale Package (CS) Bump Configuration

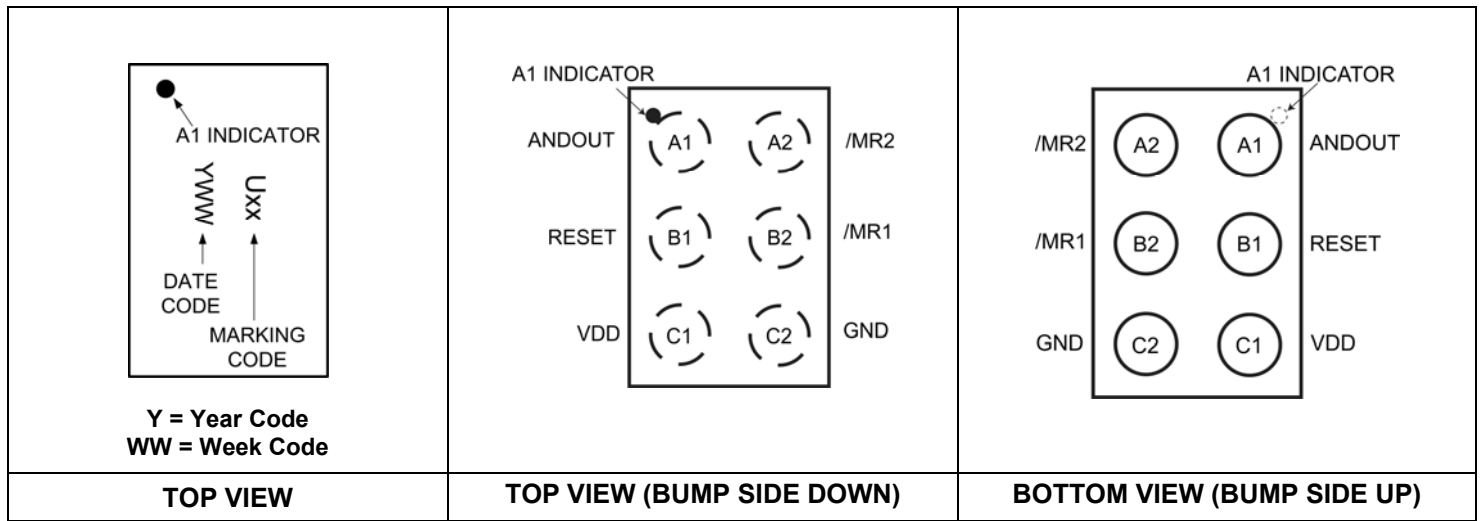

**6-Bump, 0.4mm pitch, 0.8mm x 1.2mm WLCSP Package**

Bump Designation	Bump Name	Pin Function
A1	ANDOUT	NMOS Open-Drain output, Active-Low. Asserts low 1.5ms after /MR1 and /MR2 are both asserted low. Connect a resistor greater than 5kΩ from the ANDOUT pin to VDD in order to pull up the ANDOUT output voltage when inactive. No ESD diode from ANDOUT to VDD. Please see the Functional Description and Timing Diagram sections for further details of how the ANDOUT output functions.
A2	/MR2	Manual Reset Input 2, Active-Low. Internal 65kΩ (typical) Pull-Up Resistor to VDD. Pulling both manual reset inputs low for longer than the setup period causes one RESET output pulse for the reset timeout delay period.
B1	RESET	NMOS Open-Drain output, Active-Low. Asserts low after /MR1 and /MR2 have both asserted low for longer than setup period. Connect a resistor greater than 5kΩ from the RESET pin to VDD in order to pull up the RESET output voltage when inactive. No ESD diode from RESET to VDD. Please see the Functional Description and Timing Diagram sections for further details of how the RESET output functions.
B2	/MR1	Manual Reset Input 1, Active-Low. Internal 65kΩ (typical) Pull-Up Resistor to VDD. Pulling both manual reset inputs low for longer than the setup period causes one RESET output pulse for the reset timeout delay period.
C1	VDD	Supply Voltage. Bypass to ground with minimum 0.1μF capacitor.
C2	GND	Supply Ground.

**Absolute Maximum Ratings** <sup>(1)</sup>

Supply Voltage ( $V_{DD}$ )	GND to +6.0V
Input Voltage ( $V_{/MR1}$ , $V_{/MR2}$ )	GND - 0.3V to $V_{DD}$ + 0.3V
NMOS Output Voltage ( $V_{RESET}$ , $V_{ANDOUT}$ )	GND - 0.3V to +6.0V
Lead Temperature (soldering, 10sec.)	260°C
Storage Temperature ( $T_s$ )	-55°C to +150°C
ESD Rating (Human Body Model) <sup>(3)</sup>	2kV
ESD Rating (Machine Model)	200V

**Operating Ratings** <sup>(2)</sup>

Supply Voltage ( $V_{DD}$ )	+1.5V to +5.5V
Input Voltage ( $V_{/MR1}$ , $V_{/MR2}$ )	0V to $V_{DD}$
NMOS Output Voltage ( $V_{RESET}$ , $V_{ANDOUT}$ )	0V to +5.5V
Junction Temperature ( $T_J$ )	-40°C to +85°C
Package Thermal Resistance	
6-Bump, 0.4mm Pitch WLCSP ( $\theta_{JA}$ )	125°C/W

**Electrical Characteristics** <sup>(4)</sup>

For typical values,  $V_{DD} = 3.3V$ ,  $/MR1 = /MR2 = \text{Open}$ ,  $T_J = 25^\circ\text{C}$ , **bold** values indicate  $-40^\circ\text{C} \leq T_J \leq +85^\circ\text{C}$ ; unless noted.

Parameter	Conditions	Min.	Typ.	Max.	Units
<b>Power Supply Input</b>					
Supply Voltage ( $V_{DD}$ )	Reset Output Valid	<b>1.5</b>		<b>5.5</b>	<b>V</b>
Supply Current ( $I_{DD}$ )	$V_{DD} = 3.3V$ , $/MR1 = /MR2 = V_{DD}$		2.2	<b>4.0</b>	$\mu\text{A}$
	$V_{DD} = 5.0V$ , $/MR1 = /MR2 = V_{DD}$		3.2	<b>5.0</b>	
	$V_{DD} = 3.3V$ , $/MR1 = /MR2 = \text{GND}$		120		
<b>Reset Time</b>					
Setup Period ( $t_{SETUP}$ )	Ordering Option: C	<b>5.4</b>	6	<b>6.6</b>	<b>s</b>
	Ordering Option: D	<b>7.2</b>	8	<b>8.8</b>	
	Ordering Option: E	<b>9.0</b>	10	<b>11</b>	
	Ordering Option: F	<b>10.8</b>	12	<b>13.2</b>	
Reset Timeout Period ( $t_{RESET}$ )	Ordering Option: L	<b>0.4</b>	0.5	<b>0.6</b>	<b>s</b>
	Ordering Option: M	<b>0.9</b>	1	<b>1.1</b>	
	Ordering Option: R	<b>1.8</b>	2	<b>2.2</b>	
ANDOUT Debounce Time ( $t_{DB}$ )	$V_{/MR1,2} < (V_{IL} - 100\text{mV})$	<b>1</b>	1.5	<b>2</b>	<b>ms</b>
Output Low Voltage ( $V_{OL}$ )	$V_{DD} = 4.5V$ , $I_{SINK} = 1.6\text{mA}$			<b>0.3</b>	<b>V</b>
	$V_{DD} = 3.3V$ , $I_{SINK} = 1.2\text{mA}$			<b>0.3</b>	
	$V_{DD} = 1.5V$ , $I_{SINK} = 0.5\text{mA}$			<b>0.3</b>	
Open-Drain Leakage Current ( $I_{LEAKAGE}$ )	RESET, ANDOUT Inactive $V_{RESET}$ , $V_{ANDOUT} = 5.5V$			<b>300</b>	<b>nA</b>
<b>/MR1, /MR2 Input</b>					
Input High Voltage ( $V_{IH}$ )		<b>1.2</b>			<b>V</b>
Input Low Voltage ( $V_{IL}$ )				<b>0.4</b>	<b>V</b>
Internal Pull-Up Resistance ( $R_{PU}$ )	For $/MR1$ , $/MR2$	<b>55</b>	65	<b>75</b>	<b>k<math>\Omega</math></b>

**Notes:**

- Exceeding the absolute maximum rating may damage the device.
- The device is not guaranteed to function outside its operating rating.
- Devices are ESD sensitive. Handling precautions recommended. Human body model, 1.5k $\Omega$  in series with 100pF.
- Specification for packaged product only.

# Typical Characteristics

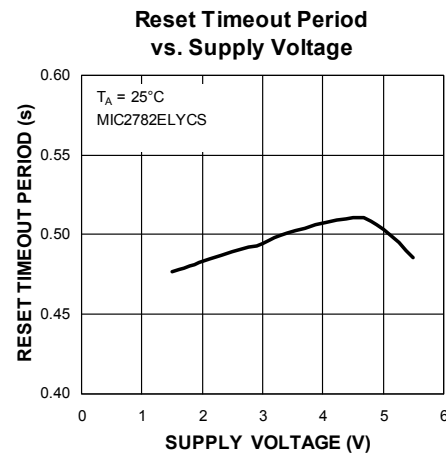
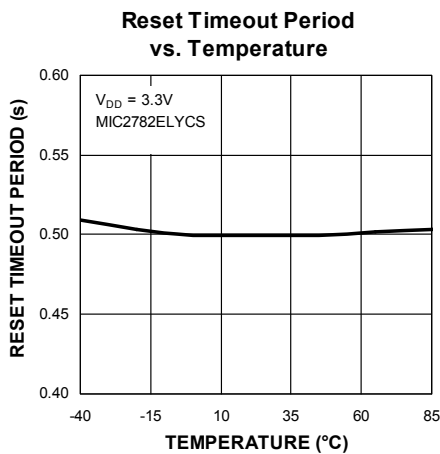
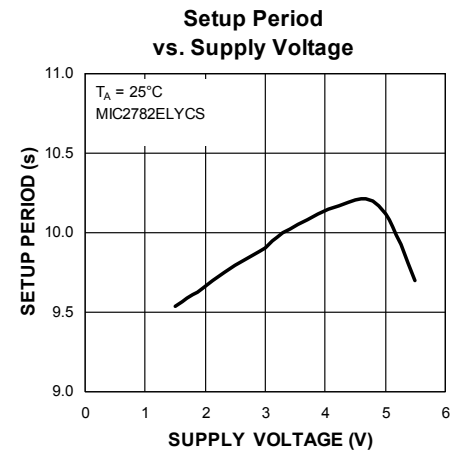
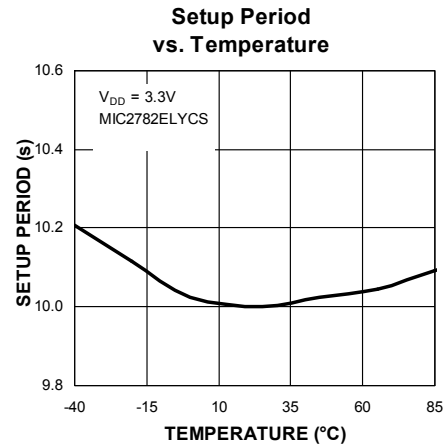
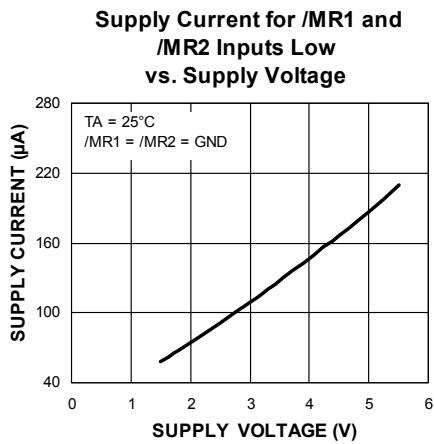
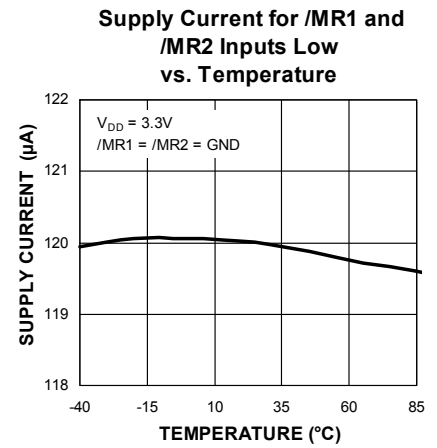
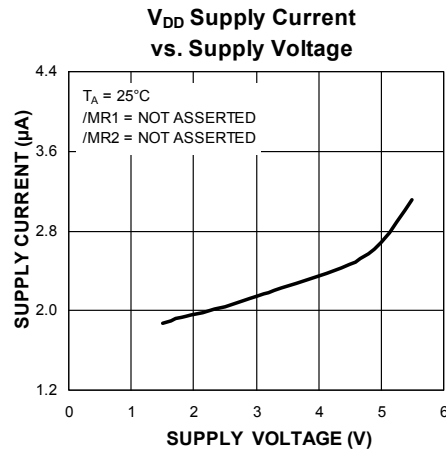
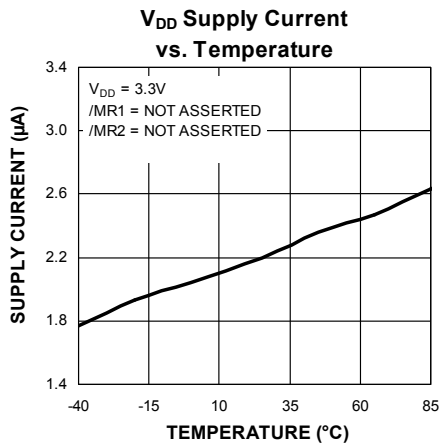

### Timing Diagram

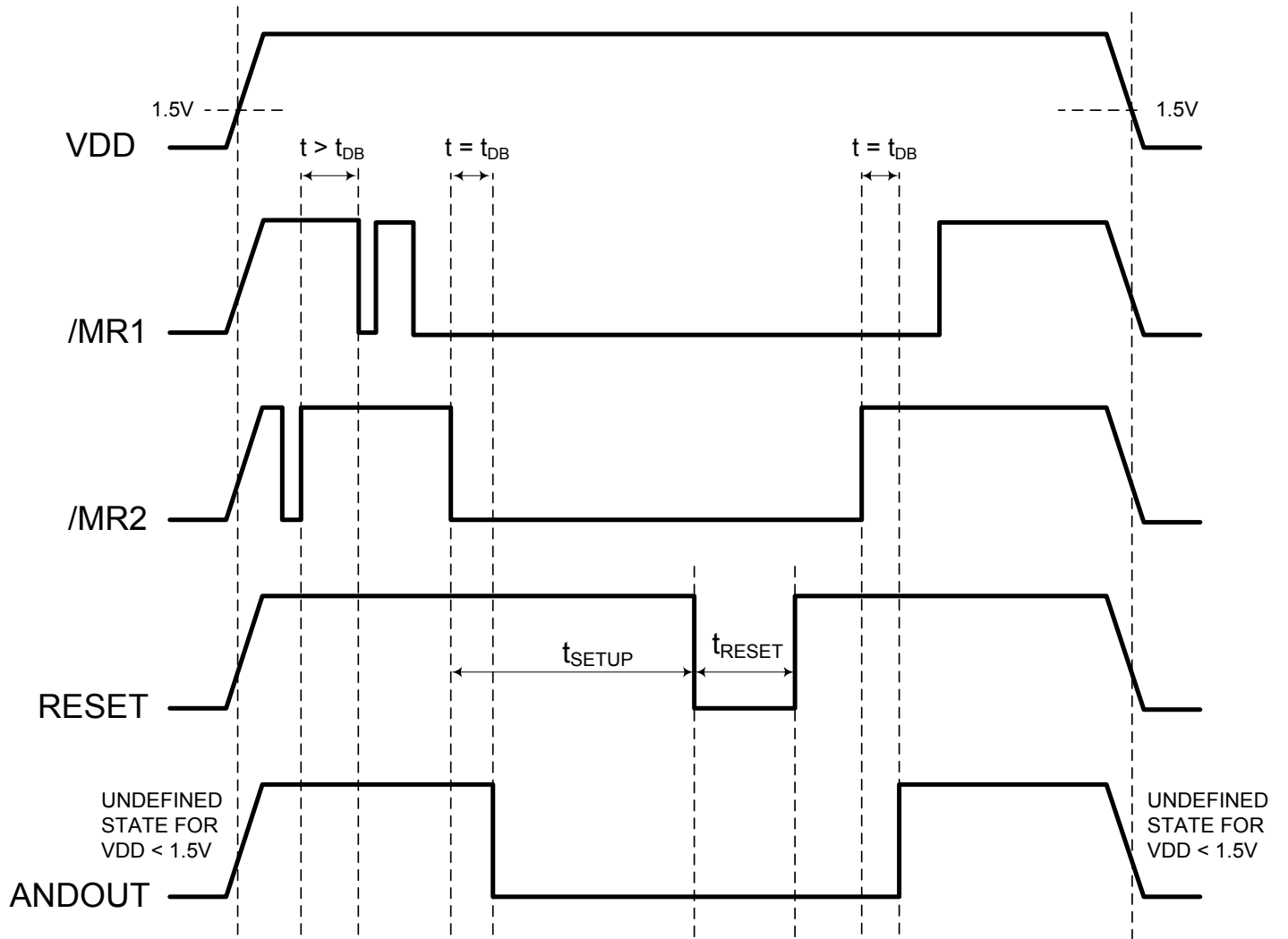

### Functional Diagram

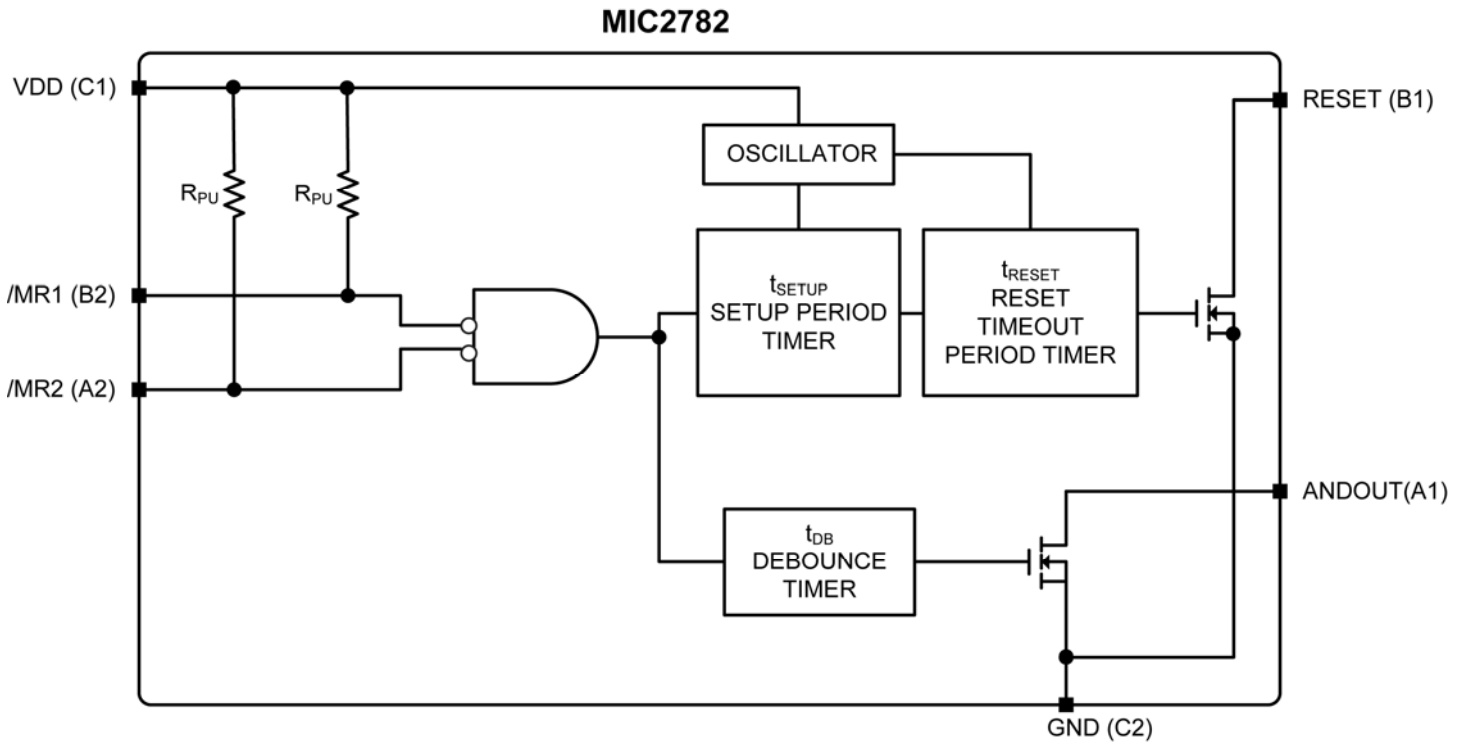

## Functional Description

### Design and Product Advantages

The MIC2782 is a dual push-button input reset IC with extended setup delay times. It is used for generating a hard reset for microcontrollers, PMICs or load disconnect switches. The dual manual reset inputs and long setup delay times help protect against accidental system resets. The fixed Reset Timeout period allows for more predictable phone or Tablet operation during hardware resets. It is used in applications such as smart phones, tablets, personal navigation devices, MP3 players and Set-Top Boxes (STB).

### General Functionality

As shown in Figure 1, if both /MR1 and /MR2 are asserted low for longer than the Setup Period ( $t_{SETUP}$ ), the RESET output will be asserted (logic-level low) for a Reset Timeout Period ( $t_{RESET}$ ). During the Setup Period, if either of the /MR1 or /MR2 inputs are de-asserted high, then the Setup Period timer will be reset. To assert the RESET output low again, both the /MR1 and /MR2 inputs will have to be asserted low together for the full duration of the Setup period.

If both /MR1 and /MR2 are asserted low for longer than the Debounce Time ( $t_{DB}$ ), then the ANDOUT output will be asserted, (logic-level low). ANDOUT will remain asserted low as long as both the /MR1 and /MR2 inputs are asserted low. If either the /MR1 or /MR2 are de-asserted for longer than the Debounce Time ( $t_{DB}$ ), then the ANDOUT output will de-assert high.

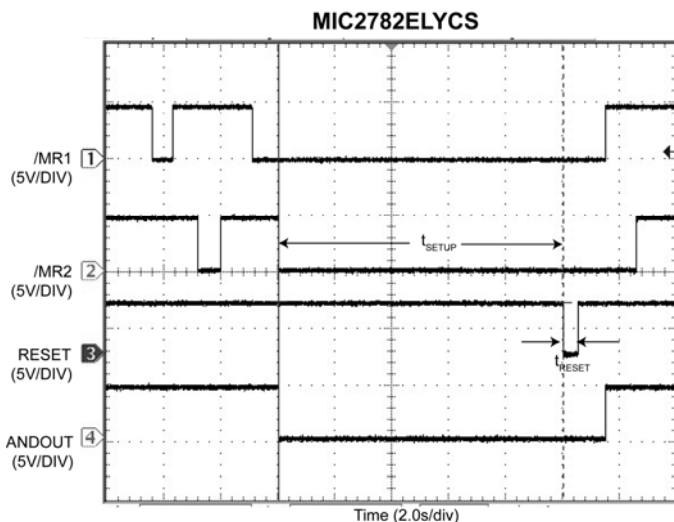

Figure 1. Manual Reset Function

Keeping both manual reset inputs low for a longer time does not generate additional RESET output pulses. De-asserting either manual reset input during the RESET

pulse duration, will not reset the Setup Timer. After the RESET pin has de-asserted high, both the manual reset inputs must be held high for more than a Debounce Time to reset the Setup Timer.

**ANDOUT Debounce Time** is a de-glitch time, typically 1.5ms, that senses the asserting of both manual reset inputs low together. A de-glitch time is needed if the manual reset inputs come from noisy push-button sources. If either manual reset inputs are asserted (or de-asserted) for less than a Debounce Time, the ANDOUT output will not respond.

### Dual Manual Reset Inputs (/MR1, /MR2)

The /MR1, /MR2 are active-low manual inputs that have integrated 65kΩ pull-up resistors to the VDD power supply. If both inputs are asserted (logic-level low) for a Setup Period ( $t_{SETUP}$ ), only one reset pulse, of width  $t_{RESET}$ , is generated. The behavior of the RESET and ANDOUT outputs is independent of the order in which the /MR1, /MR2 inputs are driven low. The MIC2782 consumes only 2μA when /MR1 and /MR2 manual inputs are de-asserted (logic-level high) together. Current consumption is typically 120μA when both manual inputs are asserted low together and 55μA when only one of the manual inputs is asserted low while the other manual input is de-asserted high.

### Outputs (RESET and ANDOUT)

The RESET and ANDOUT outputs are simple open-drain N-channel MOSFET structures that require a pull-up resistor. For most applications, the pull-up voltage will be the same as the power supply that supplies VDD to the MIC2782. As shown in Figure 2, it is possible to tie this resistor to some other voltage, other than VDD, thus enabling level-shifting of the RESET or ANDOUT outputs. The pull-up voltage must be limited to 5.5V to avoid damaging the MIC2782. The pull-up resistor must be small enough to supply current to the inputs and leakage paths that are driven by the RESET or ANDOUT outputs. A recommended value is 100kΩ.

Since the RESET and ANDOUT outputs are open-drain, several reset sources can be wire-ORed, in parallel, to allow resets from multiple sources.



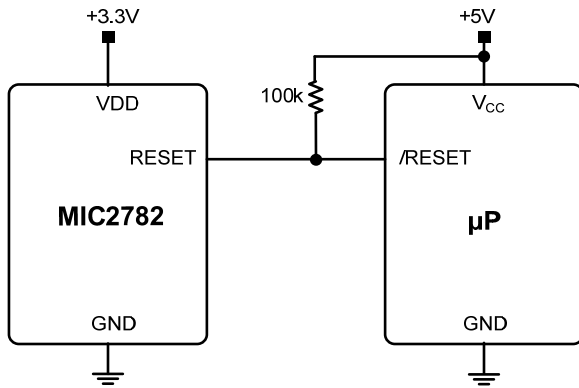

Figure 2. MIC2782 Used in Multiple Supply System

### Bypass Capacitor from VDD to GND

A 0.1μF input bypass capacitor must be placed from VDD (Pin C1) to GND (Pin C2).

## Typical Applications

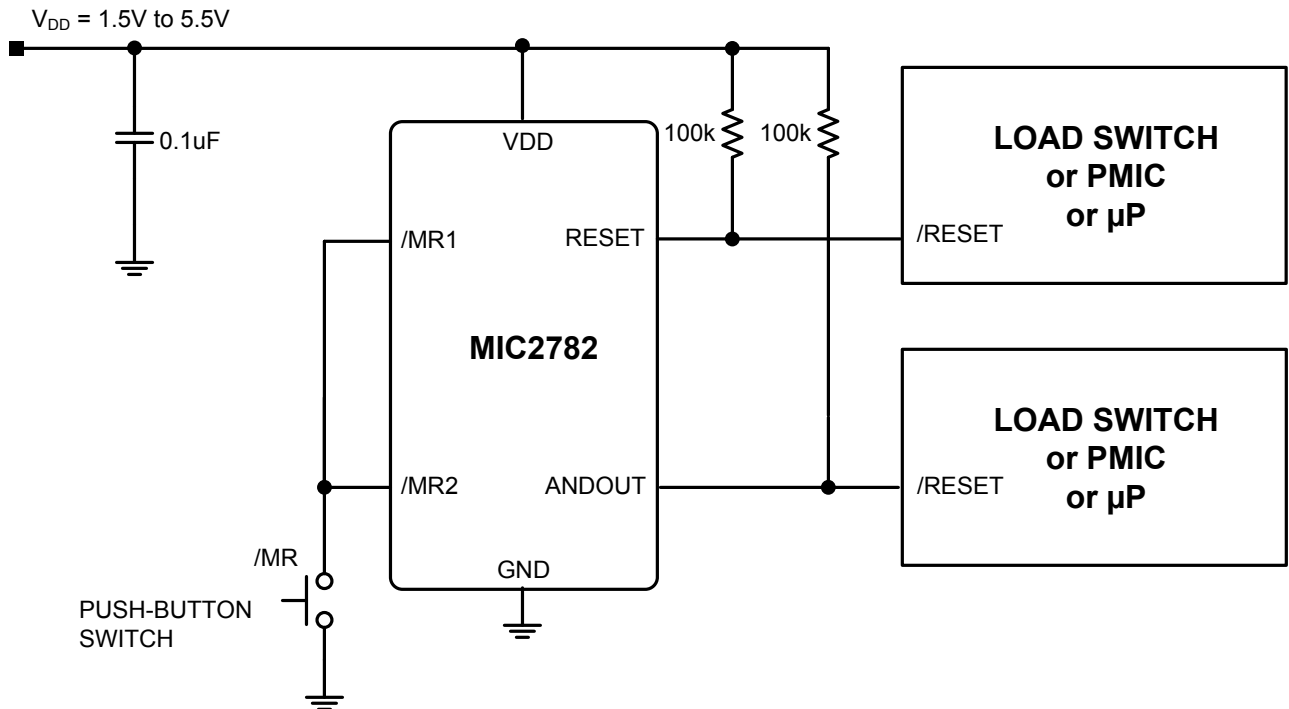

Figure 3. Single Button application for MIC2782 used for Microcontroller Reset

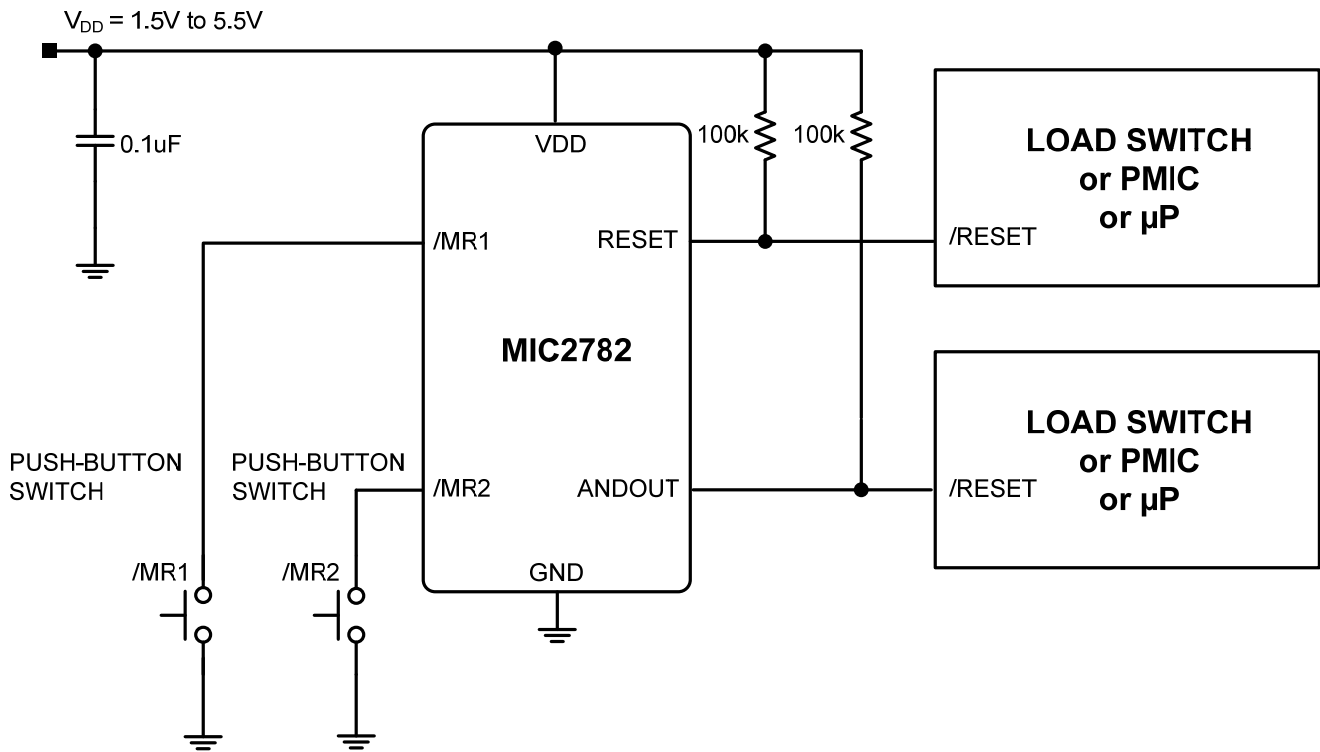
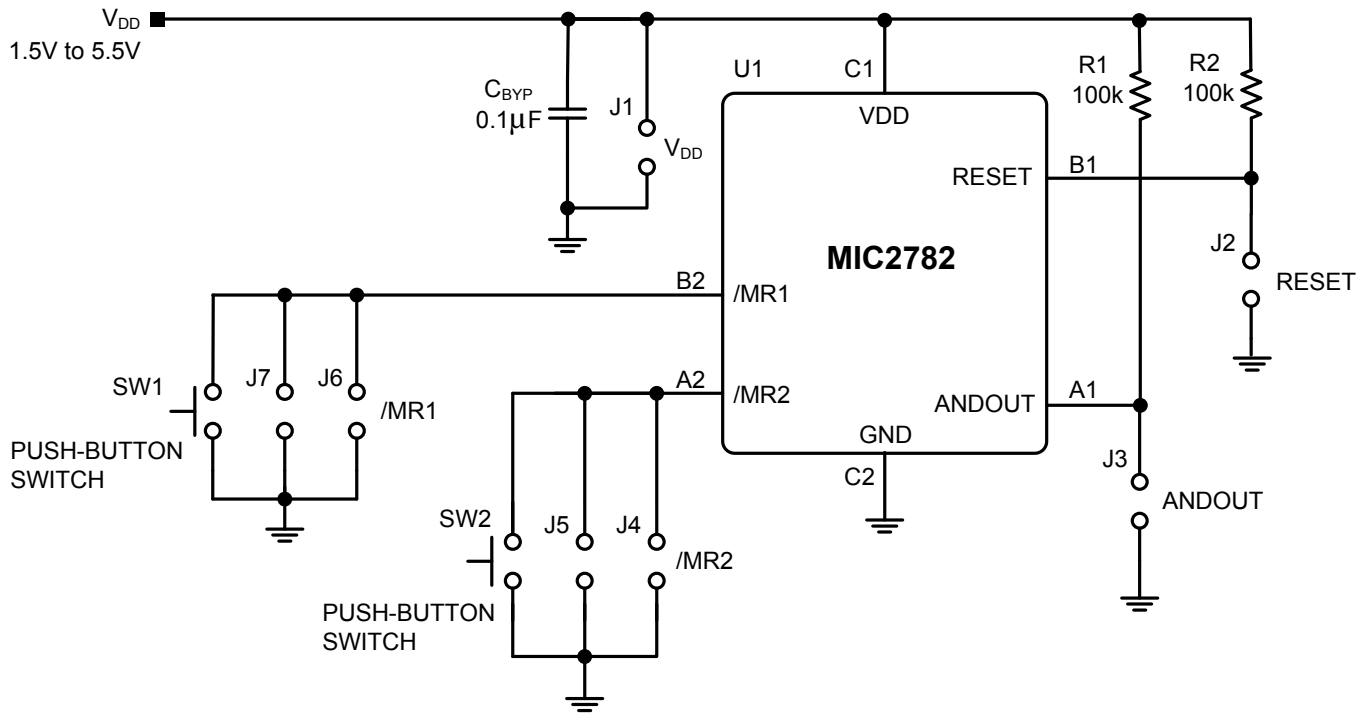

Figure 4. Dual Button application for MIC2782 used for Microcontroller Reset

## Evaluation Board Schematic



## Bill of Materials

Item	Part Number	Manufacturer	Description	Qty.
C1	GRM188R71C104KA01D <sup>(1)</sup>	Murata	0.1µF, 16V capacitor, X7R, 0603	1
R1, R2	CRCW0603100KJNEA <sup>(2)</sup>	Vishay	100k, 5% resistor, 0603	2
U1	MIC2782ELYCS <sup>(3)</sup>	Micrel, Inc.	Dual-Input Push Button Reset IC	1

### Notes:

1. Murata Tel: [www.murata.com](http://www.murata.com).
2. Vishay Tel: [www.vishay.com](http://www.vishay.com).
3. Micrel, Inc.: [www.micrel.com](http://www.micrel.com).

# PCB Layout Recommendations

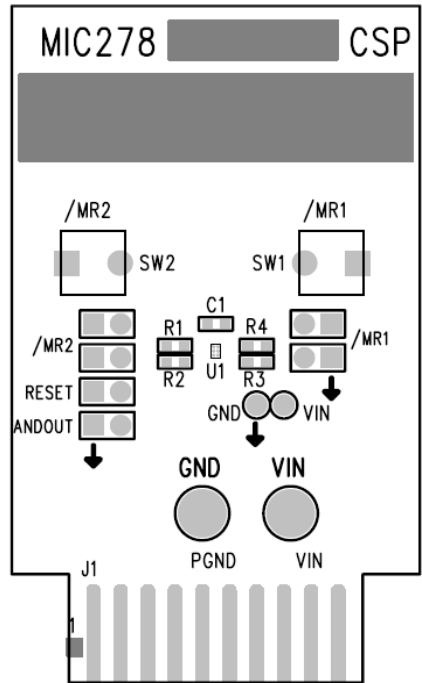

Top Silkscreen

### PCB Layout Recommendations (Continued)

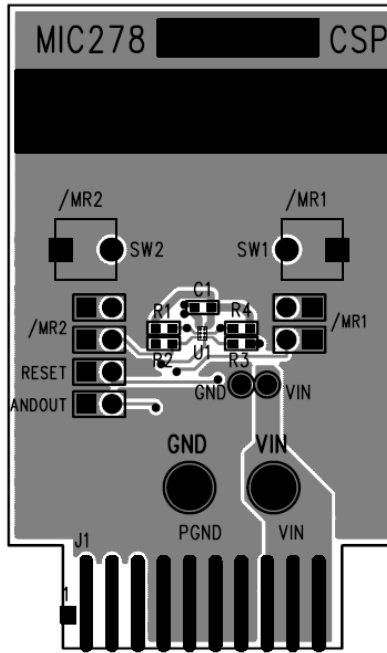

Copper Layer 1 (Top Layer)

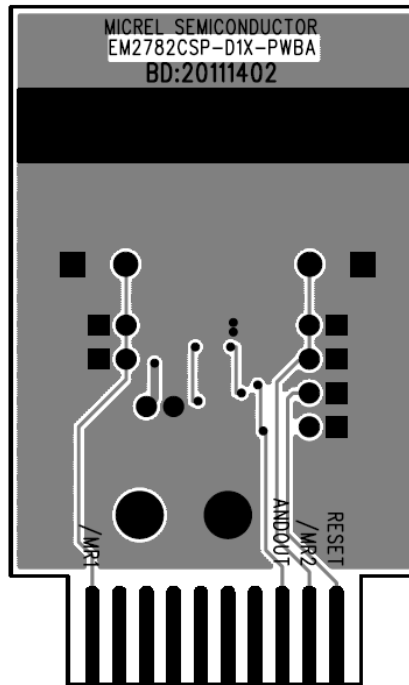

Copper Layer 2 (Bottom Layer)

### PCB Layout Recommendations (Continued)

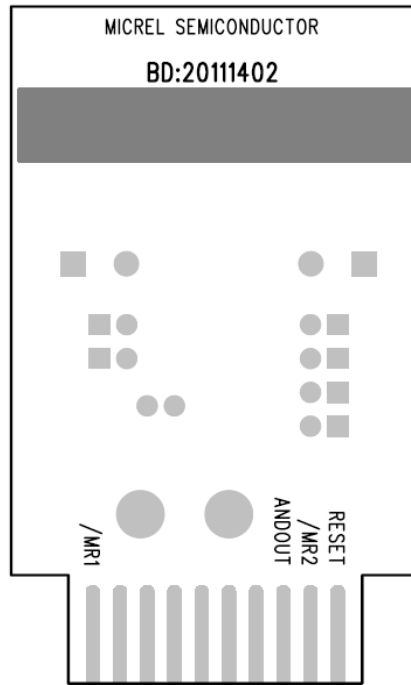

**Bottom Silkscreen**

**Package Information**

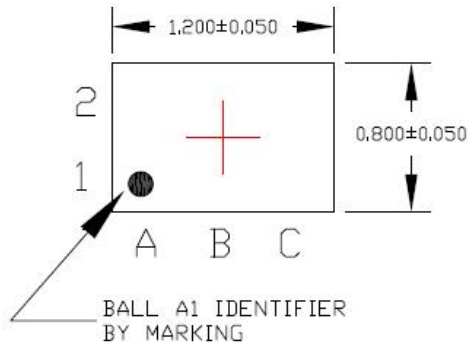

TOP VIEW

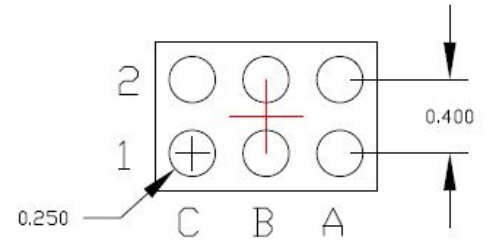

BOTTOM VIEW

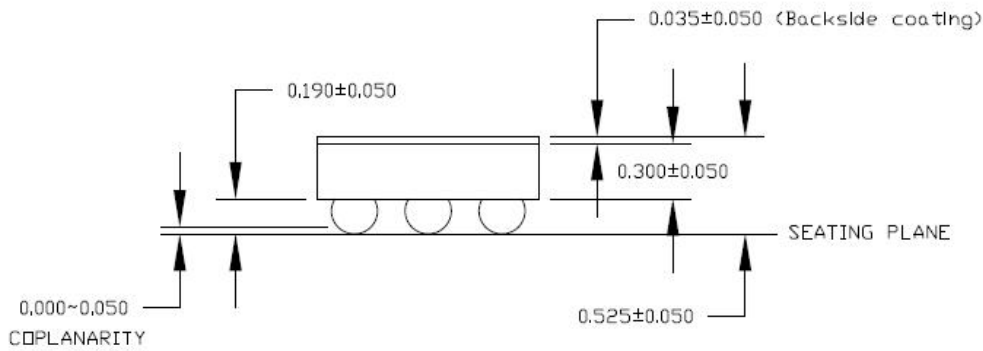

SIDE VIEW

**6-Bump, 0.4mm Pitch 0.8mm x 1.2mm WLCSP (CS) Package Drawing**

---

**MICREL, INC. 2180 FORTUNE DRIVE SAN JOSE, CA 95131 USA**  
TEL +1 (408) 944-0800 FAX +1 (408) 474-1000 WEB <http://www.micrel.com>

Micrel makes no representations or warranties with respect to the accuracy or completeness of the information furnished in this data sheet. This information is not intended as a warranty and Micrel does not assume responsibility for its use. Micrel reserves the right to change circuitry, specifications and descriptions at any time without notice. No license, whether express, implied, arising by estoppel or otherwise, to any intellectual property rights is granted by this document. Except as provided in Micrel's terms and conditions of sale for such products, Micrel assumes no liability whatsoever, and Micrel disclaims any express or implied warranty relating to the sale and/or use of Micrel products including liability or warranties relating to fitness for a particular purpose, merchantability, or infringement of any patent, copyright or other intellectual property right.

Micrel Products are not designed or authorized for use as components in life support appliances, devices or systems where malfunction of a product can reasonably be expected to result in personal injury. Life support devices or systems are devices or systems that (a) are intended for surgical implant into the body or (b) support or sustain life, and whose failure to perform can be reasonably expected to result in a significant injury to the user. A Purchaser's use or sale of Micrel Products for use in life support appliances, devices or systems is a Purchaser's own risk and Purchaser agrees to fully indemnify Micrel for any damages resulting from such use or sale.

© 2012 Micrel, Incorporated.