



25N06

Preliminary

Power MOSFET

25A, 60V N-CHANNEL POWER MOSFET

DESCRIPTION

The UTC **25N06** is an N-channel enhancement mode power MOSFET, which provides low gate charge, avalanche rugged technology, and so on.

The UTC **25N06** is universally applied in DC-DC & DC-AC converters, motor control, high current, high speed switching, solenoid and relay drivers, regulators, audio amplifiers, automotive environment.

FEATURES

- * Low Gate Charge
- * $R_{DS(on)} = 0.048 \Omega$ (TYP.)
- * Avalanche Rugged Technology
- * 100% Avalanche Tested
- * Repetitive Avalanche at 100°C
- * High Current Capability
- * Operating Temperature: 150°C
- * Application Oriented Characterization

SYMBOL

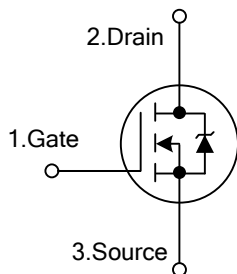

ORDERING INFORMATION

Ordering Number		Package	Pin Assignment			Packing
Lead Free	Halogen Free		1	2	3	
25N06L-TA3-T	25N06G-TA3-T	TO-220	G	D	S	Tube
25N06L-TN3-T	25N06G-TN3-T	TO-252	G	D	S	Tube
25N06L-TN3-R	25N06G-TN3-R	TO-252	G	D	S	Tape Reel

Note: Pin Assignment: G: Gate, D: Drain, S: Source

<p>25N06L-TA3-T</p> <p>(1)Packing Type</p> <p>(2)Package Type</p> <p>(3)Lead Free</p>	<p>(1) T: Tube, R: Tape Reel</p> <p>(2) TA3: TO-220, TN3: TO-252</p> <p>(3) G: Halogen Free, L: Lead Free</p>
---	---

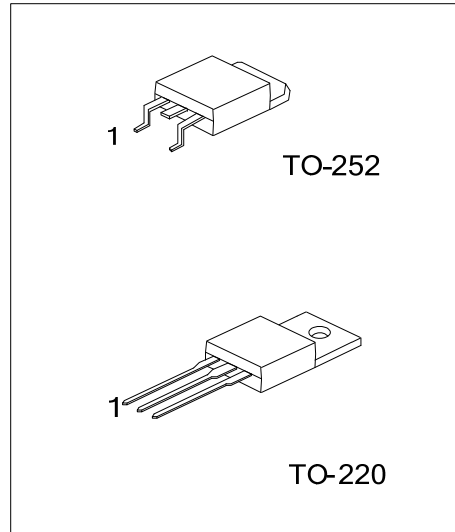

■ ABSOLUTE MAXIMUM RATINGS

PARAMETER		SYMBOL	RATINGS	UNIT
Drain-Source Voltage ($V_{GS}=0$)		V_{DS}	60	V
Drain-Gate Voltage ($R_{GS}=20k\Omega$)		V_{DGR}	60	V
Gate-Source Voltage		V_{GS}	± 20	V
Drain Current (Continuous)	$T_C=25^\circ\text{C}$	I_D	25	A
	$T_C=100^\circ\text{C}$		17	A
Drain Current (Pulsed) (Note 2)		I_{DM}	100	A
Single Pulse Avalanche Energy (starting $T_J=25^\circ\text{C}$, $I_D=25\text{A}$, $V_{DD}=25\text{V}$)		E_{AS}	100	mJ
Power Dissipation at $T_C=25^\circ\text{C}$	TO-220	P_D	90	W
	TO-252		41	
Junction Temperature		T_J	150	$^\circ\text{C}$
Storage Temperature		T_{STG}	-65 ~ +150	$^\circ\text{C}$

Note: 1. Absolute maximum ratings are those values beyond which the device could be permanently damaged.

Absolute maximum ratings are stress ratings only and functional device operation is not implied.

2. Pulse width limited by safe operating area

■ THERMAL DATA

PARAMETER		SYMBOL	RATINGS	UNIT
Junction to Ambient	TO-220	θ_{JA}	62.5	$^\circ\text{C/W}$
	TO-252		100	
Junction to Case	TO-220	θ_{JC}	1.57	$^\circ\text{C/W}$
	TO-252		3	

■ ELECTRICAL CHARACTERISTICS ($T_C = 25^\circ\text{C}$, unless otherwise specified)

PARAMETER	SYMBOL	TEST CONDITIONS	MIN	TYP	MAX	UNIT
OFF CHARACTERISTICS						
Drain-Source Breakdown Voltage	BV_{DSS}	$I_D = 250\mu\text{A}$, $V_{GS} = 0\text{V}$	60			V
Drain-Source Leakage Current ($V_{GS} = 0$)	I_{DSS}	$V_{DS} = \text{Max Rating}$			1	μA
		$V_{DS} = \text{Max Rating} \times 0.8$, $T_C = 125^\circ\text{C}$			10	
Gate- Source Leakage Current ($V_{DS} = 0$)	I_{GSS}	$V_{GS} = \pm 20\text{V}$			± 100	nA
ON CHARACTERISTICS						
Gate Threshold Voltage	$V_{GS(TH)}$	$V_{DS} = V_{GS}$, $I_D = 250\mu\text{A}$	2	2.9	4	V
Static Drain-Source On-State Resistance	$R_{DS(ON)}$	$V_{GS} = 10\text{V}$, $I_D = 12.5\text{A}$		0.048	0.065	Ω
On State Drain Current	$I_{D(on)}$	$V_{DS} > I_{D(on)} \times R_{DS(ON)MAX}$, $V_{GS} = 10\text{V}$	25			A
Forward Transconductance (Note 1)	g_{FS}	$V_{DS} > I_{D(on)} \times R_{DS(ON)MAX}$, $I_D = 12.5\text{A}$	7	11		S
DYNAMIC PARAMETERS						
Input Capacitance	C_{ISS}	$V_{GS} = 0\text{V}$, $V_{DS} = 25\text{V}$, $f = 1\text{MHz}$		700	900	pF
Output Capacitance	C_{OSS}			320	450	pF
Reverse Transfer Capacitance	C_{RSS}			90	150	pF
SWITCHING PARAMETERS						
Total Gate Charge	Q_G	$V_{DD} = 40\text{V}$, $V_{GS} = 10\text{V}$, $I_D = 25\text{A}$		26	40	nC
Gate to Source Charge	Q_{GS}			8		nC
Gate to Drain Charge	Q_{GD}			9		nC
Turn-ON Delay Time	$t_{D(ON)}$	$V_{DD} = 30\text{V}$, $I_D = 3\text{A}$, $R_G = 50\Omega$, $V_{GS} = 10\text{V}$		30	45	ns
Rise Time	t_R			90	130	ns
Turn-OFF Delay Time	$t_{D(OFF)}$	$V_{DD} = 40\text{V}$, $I_D = 25\text{A}$, $R_G = 50\Omega$, $V_{GS} = 10\text{V}$		80	120	ns
Fall-Time	t_F			80	120	ns
SOURCE- DRAIN DIODE RATINGS AND CHARACTERISTICS						
Drain-Source Diode Forward Voltage	V_{SD}	$I_{SD} = 25\text{A}$, $V_{GS} = 0\text{V}$ (Note 1)			1.5	V
Source-Drain Current	I_{SD}				25	A
Source-Drain Current (Pulsed) (Note 2)	I_{SDM}				100	A

Note: 1. Pulsed: Pulse duration = 300 μs , duty cycle 1.5%.

2. Pulse width limited by safe operating area

■ SWITCHING TIME TEST CIRCUIT

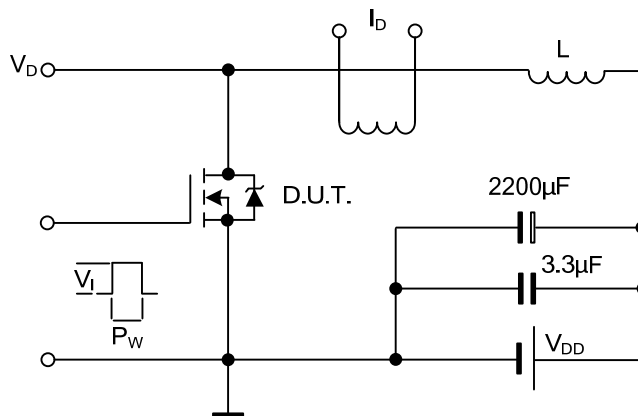

Fig. 1 Unclamped Inductive Load Test Circuits

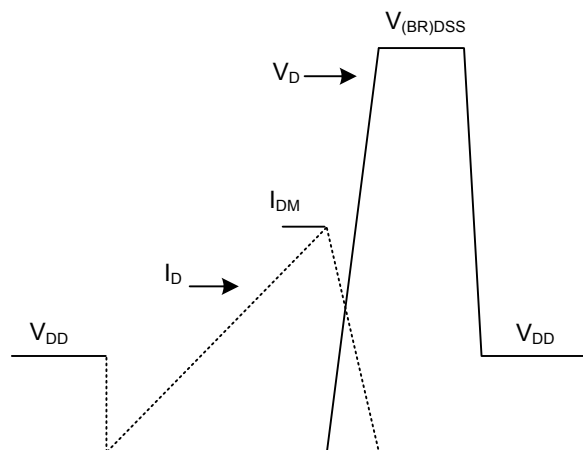

Fig. 2 Unclamped Inductive Waveforms

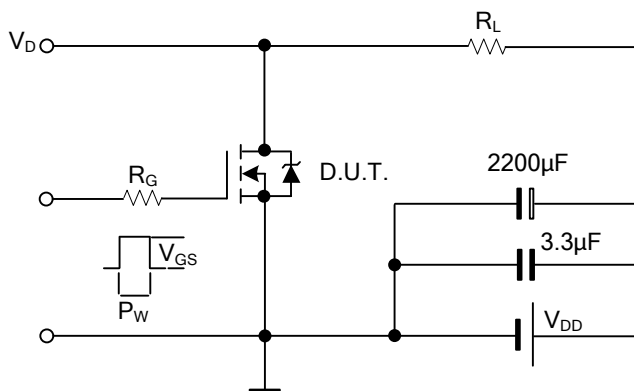

Fig. 3. Switching Times Test Circuits For Resistive Load

SWITCHING TIME TEST CIRCUIT (Cont.)

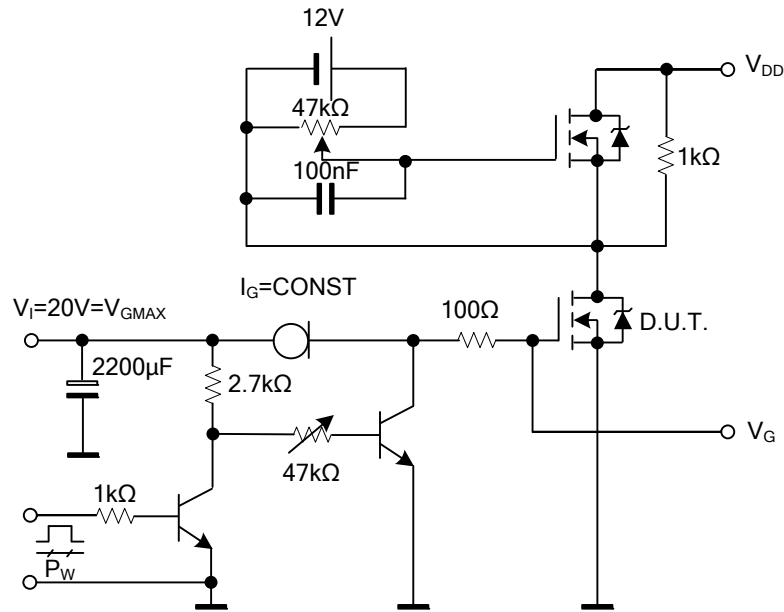

Fig. 4 Gate Charge Test Circuit

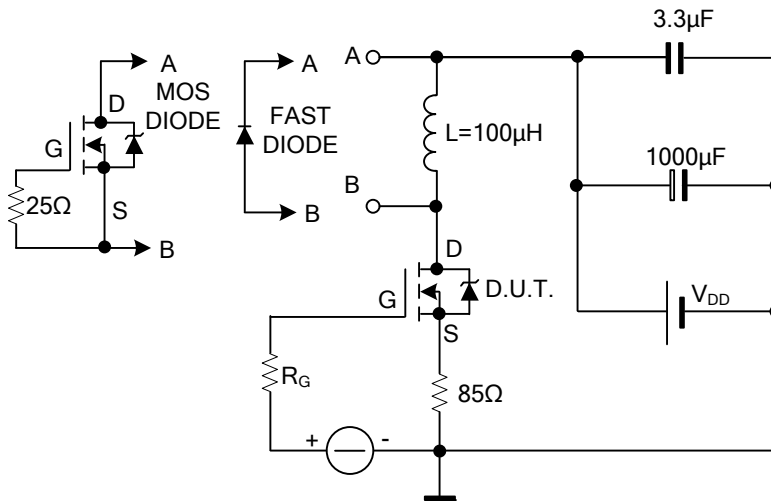

Fig. 5 Test Circuit For Inductive Load Switching And Diode Reverse Recovery Time

UTC assumes no responsibility for equipment failures that result from using products at values that exceed, even momentarily, rated values (such as maximum ratings, operating condition ranges, or other parameters) listed in products specifications of any and all UTC products described or contained herein. UTC products are not designed for use in life support appliances, devices or systems where malfunction of these products can be reasonably expected to result in personal injury. Reproduction in whole or in part is prohibited without the prior written consent of the copyright owner. The information presented in this document does not form part of any quotation or contract, is believed to be accurate and reliable and may be changed without notice.