

SGR20N40L / SGU20N40L

General Description

Insulated Gate Bipolar Transistors (IGBTs) with trench gate structure have superior performance in conduction and switching to planar gate structure, and also have wide noise immunity. These devices are well suitable for strobe applications

Features

- High Input Impedance
- High Peak Current Capability (150A)
- Easy Gate Drive

Application

Strobe Flash

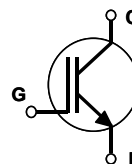
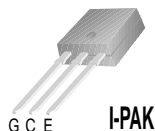
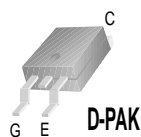

Absolute Maximum Ratings T_C = 25°C unless otherwise noted

Symbol	Description	SGR / SGU20N40L	Units
V _{CES}	Collector - Emitter Voltage	400	V
V _{GES}	Gate - Emitter Voltage	± 6	V
I _{CM (1)}	Pulsed Collector Current	150	A
P _C	Maximum Power Dissipation @ T _C = 25°C	45	W
T _J	Operating Junction Temperature	-40 to +150	°C
T _{stg}	Storage Temperature Range	-40 to +150	°C
T _L	Maximum Lead Temp. for soldering Purposes, 1/8" from case for 5 seconds	300	°C

Notes :

(1) Repetitive rating : Pulse width limited by max. junction temperature

Thermal Characteristics

Symbol	Parameter	Typ.	Max.	Units
R _{θJC}	Thermal Resistance, Junction-to-Case	--	3.0	°C/W
R _{θJA (D-PAK)}	Thermal Resistance, Junction-to-Ambient (PCB Mount) (2)	--	50	°C/W
R _{θJA (I-PAK)}	Thermal Resistance, Junction-to-Ambient	--	110	°C/W

Notes :

(2) Mounted on 1" square PCB (FR4 or G-10 Material)

Electrical Characteristics of IGBT $T_C = 25^\circ\text{C}$ unless otherwise noted

Symbol	Parameter	Test Conditions	Min.	Typ.	Max.	Units
Off Characteristics						
BV_{CES}	Collector-Emitter Breakdown Voltage	$V_{GE} = 0V, I_C = 1mA$	450	--	--	V
I_{CES}	Collector Cut-Off Current	$V_{CE} = V_{CES}, V_{GE} = 0V$	--	--	10	μA
I_{GES}	G-E Leakage Current	$V_{GE} = V_{GES}, V_{CE} = 0V$	--	--	± 0.1	μA
On Characteristics						
$V_{GE(th)}$	G-E Threshold Voltage	$I_C = 1mA, V_{CE} = V_{GE}$	0.5	1.0	1.4	V
$V_{CE(sat)}$	C-E Saturation Current	$I_C = 150A, V_{GE} = 4.5V$	2.0	4.5	8.0	V
Dynamic Characteristics						
C_{ies}	Input Capacitance	$V_{GE} = 0V, V_{CE} = 30V,$ $f = 1MHz$	--	3800	--	pF
C_{oes}	Output Capacitance		--	50	--	pF
C_{res}	Reverse Transfer Capacitance		--	35	--	pF
Switching Characteristics						
$t_{d(on)}$	Turn-On Delay Time	$V_{CC} = 300V, I_C = 150A,$ $V_{GE} = 4.5V, R_G = 15\Omega^*$ Resistive Load	--	0.2	--	μs
t_r	Rise Time		--	1.7	--	μs
$t_{d(off)}$	Turn-Off Delay Time		--	0.3	0.5	μs
t_f	Fall Time		--	1.5	2.0	μs

* Notes : Recommendation of R_G Value : $R_G \geq 15\Omega$

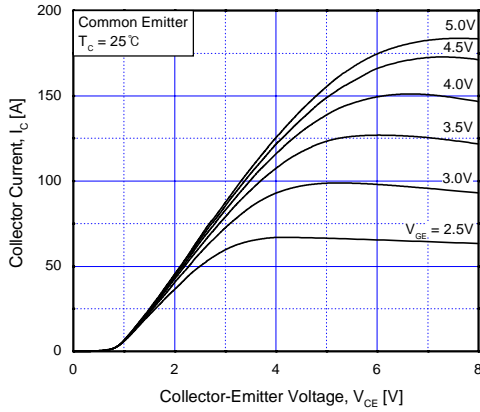

Fig 1. Typical Output Characteristics

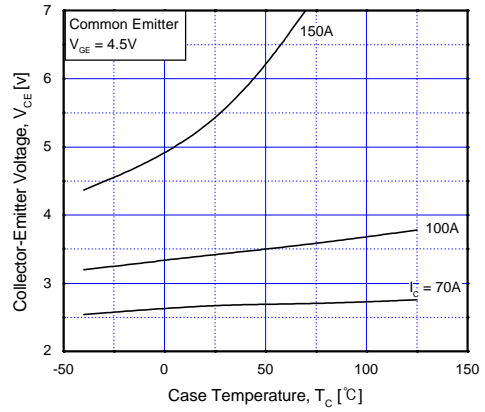

Fig 2. Saturation Voltage vs. Case Temperature at Variant Current Level

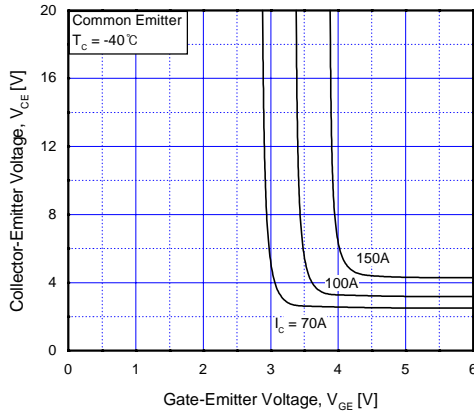

Fig 3. Saturation Voltage vs. V_{GE}

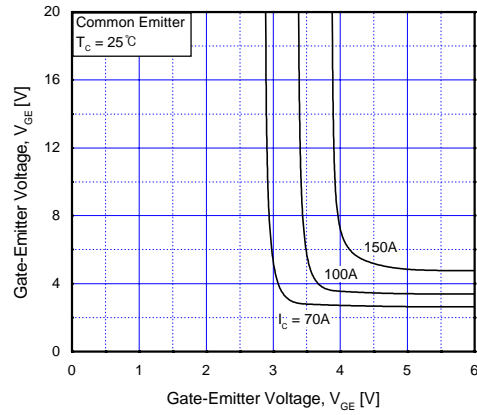

Fig 4. Saturation Voltage vs. V_{GE}

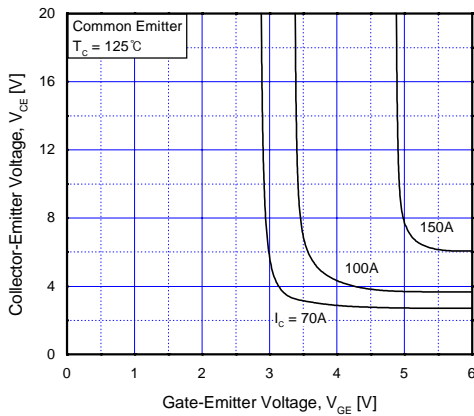

Fig 5. Saturation Voltage vs. V_{GE}

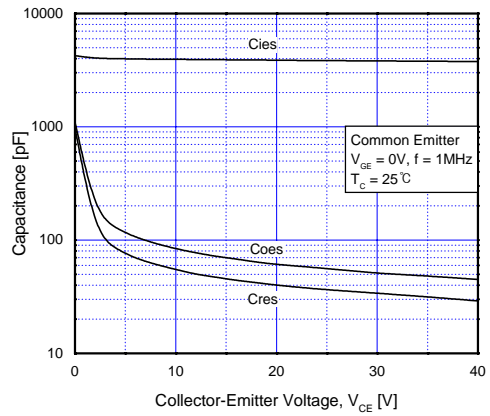

Fig 6. Capacitance Characteristics

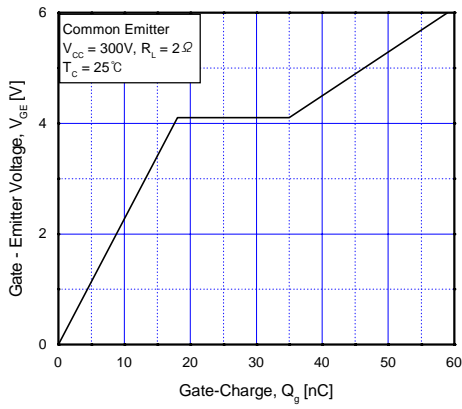

Fig 7. Turn-On Characteristics vs. Gate Resistance

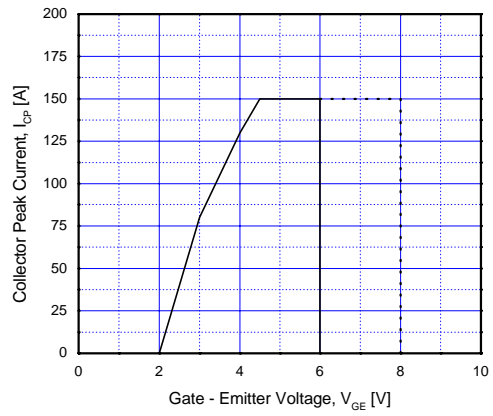

Fig 8. Collector Current Limit vs. Gate - Emitter Voltage Limit

TRADEMARKS

The following are registered and unregistered trademarks Fairchild Semiconductor owns or is authorized to use and is not intended to be an exhaustive list of all such trademarks.

ACE _x TM	FAST _r TM	QFET TM	VCX TM
Bottomless TM	GlobalOptoisolator TM	QS TM	
CoolFET TM	GTO TM	QT Optoelectronics TM	
CROSSVOLT TM	HiSeC TM	Quiet Series TM	
DOMET TM	ISOPLANAR TM	SuperSOT TM -3	
E ² CMOS TM	MICROWIRE TM	SuperSOT TM -6	
EnSigna TM	OPTOLOGIC TM	SuperSOT TM -8	
FACT TM	OPTOPLANAR TM	SyncFET TM	
FACT Quiet Series TM	POP TM	TinyLogic TM	
FAST [®]	PowerTrench [®]	UHC TM	

DISCLAIMER

FAIRCHILD SEMICONDUCTOR RESERVES THE RIGHT TO MAKE CHANGES WITHOUT FURTHER NOTICE TO ANY PRODUCTS HEREIN TO IMPROVE RELIABILITY, FUNCTION OR DESIGN. FAIRCHILD DOES NOT ASSUME ANY LIABILITY ARISING OUT OF THE APPLICATION OR USE OF ANY PRODUCT OR CIRCUIT DESCRIBED HEREIN; NEITHER DOES IT CONVEY ANY LICENSE UNDER ITS PATENT RIGHTS, NOR THE RIGHTS OF OTHERS.

LIFE SUPPORT POLICY

FAIRCHILD'S PRODUCTS ARE NOT AUTHORIZED FOR USE AS CRITICAL COMPONENTS IN LIFE SUPPORT DEVICES OR SYSTEMS WITHOUT THE EXPRESS WRITTEN APPROVAL OF FAIRCHILD SEMICONDUCTOR INTERNATIONAL.

As used herein:

1. Life support devices or systems are devices or systems which, (a) are intended for surgical implant into the body, or (b) support or sustain life, or (c) whose failure to perform when properly used in accordance with instructions for use provided in the labeling, can be reasonably expected to result in significant injury to the user.
2. A critical component is any component of a life support device or system whose failure to perform can be reasonably expected to cause the failure of the life support device or system, or to affect its safety or effectiveness.

PRODUCT STATUS DEFINITIONS

Definition of Terms

Datasheet Identification	Product Status	Definition
Advance Information	Formative or In Design	This datasheet contains the design specifications for product development. Specifications may change in any manner without notice.
Preliminary	First Production	This datasheet contains preliminary data, and supplementary data will be published at a later date. Fairchild Semiconductor reserves the right to make changes at any time without notice in order to improve design.
No Identification Needed	Full Production	This datasheet contains final specifications. Fairchild Semiconductor reserves the right to make changes at any time without notice in order to improve design.
Obsolete	Not In Production	This datasheet contains specifications on a product that has been discontinued by Fairchild semiconductor. The datasheet is printed for reference information only.