

LH28F400SU-LC

4M (512K × 8, 256K × 16) Flash Memory

FEATURES

- User-Configurable x8 or x16 Operation
- 5 V Write/Erase Operation (5 V V_{PP} , 3.3 V V_{CC})
 - No Requirement for DC/DC Converter to Write/Erase
- 150 ns Maximum Access Time ($V_{CC} = 3.3 V \pm 0.3 V$)
- Minimum 2.7 V Read Capability
 - 190 ns Maximum Access Time ($V_{CC} = 2.7 V$)
- 32 Independently Lockable Blocks (16K)
- 100,000 Erase Cycles per Block
- Automated Byte Write/Block Erase
 - Command User Interface
 - Status Register
 - $\overline{RY}/\overline{BY}$ Status Output
- System Performance Enhancement
 - Erase Suspend for Read
 - Two-Byte Write
 - Full Chip Erase
- Data Protection - Hardware Erase/Write Lockout during Power Transitions
 - Software Erase/Write Lockout
- Independently Lockable for Write/Erase on Each Block (Lock Block and Protect Set/Reset)
- 4 μA (Typ.) I_{CC} in CMOS Standby
- 0.2 μA (Typ.) Deep Power-Down
- Extended Temperature Operation
 - $-40^{\circ}C$ to $+85^{\circ}C$
- State-of-the-Art 0.55 μm ETOX™ Flash Technology
- 56-Pin, 1.2 mm × 14 mm × 20 mm TSOP (Type I) Package
- 48-Pin 1.2 mm × 12 mm × 18 mm TSOP (Type I) Package
- 44-Pin 600-mil SOP Package

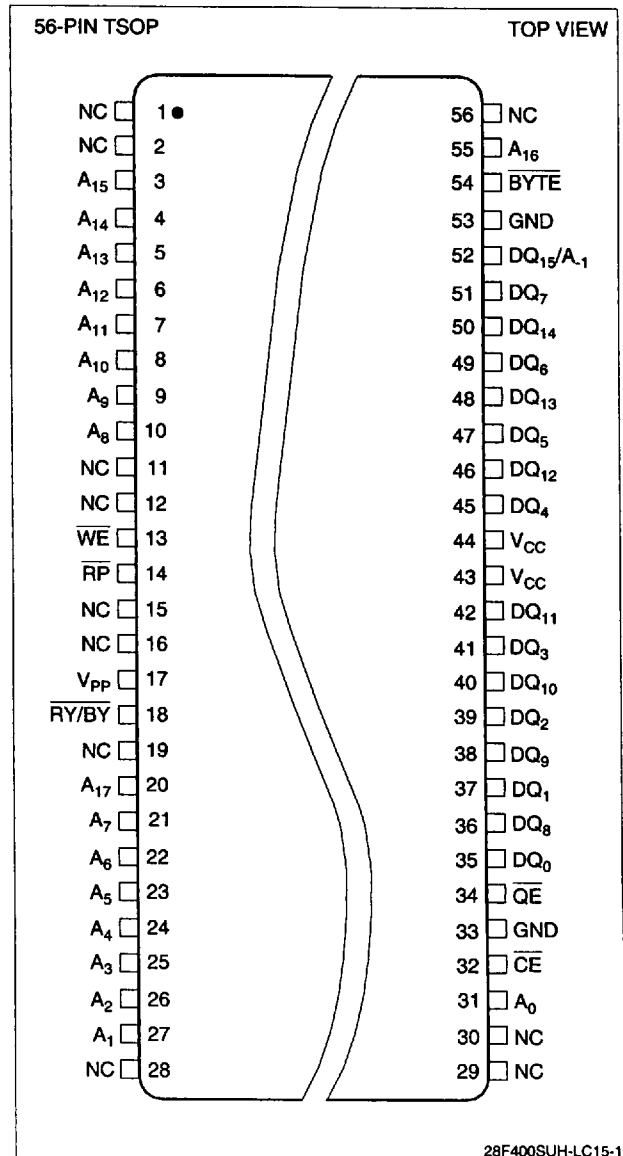

Figure 1. 56-Pin TSOP Configuration

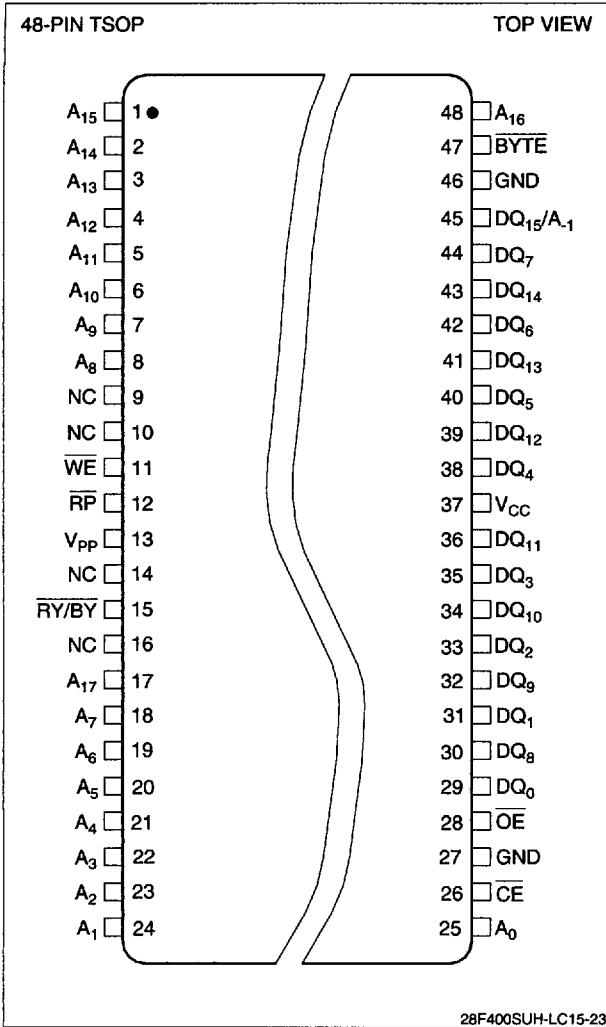

Figure 2. 48-Pin TSOP Configuration

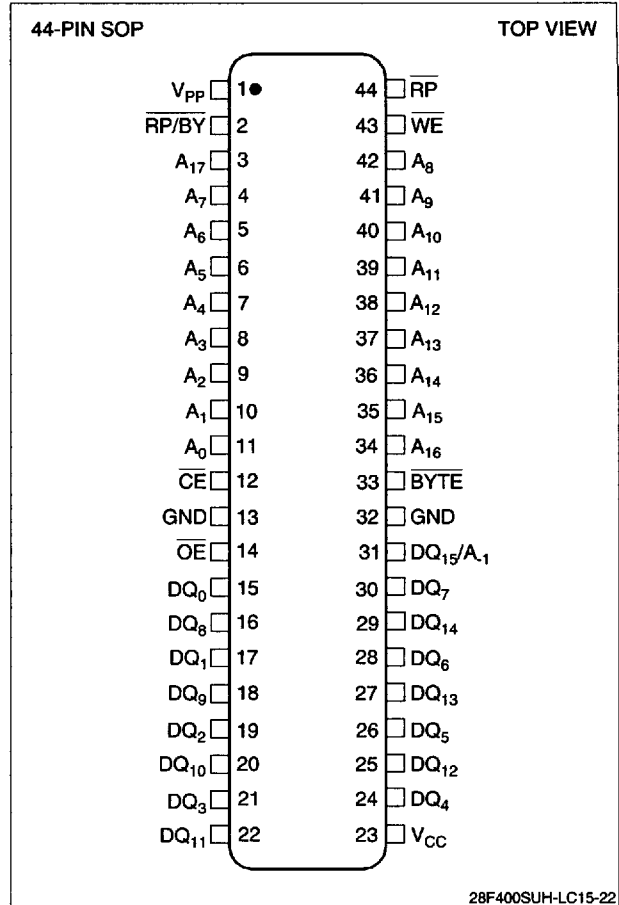

Figure 3. 44-Pin SOP Configuration

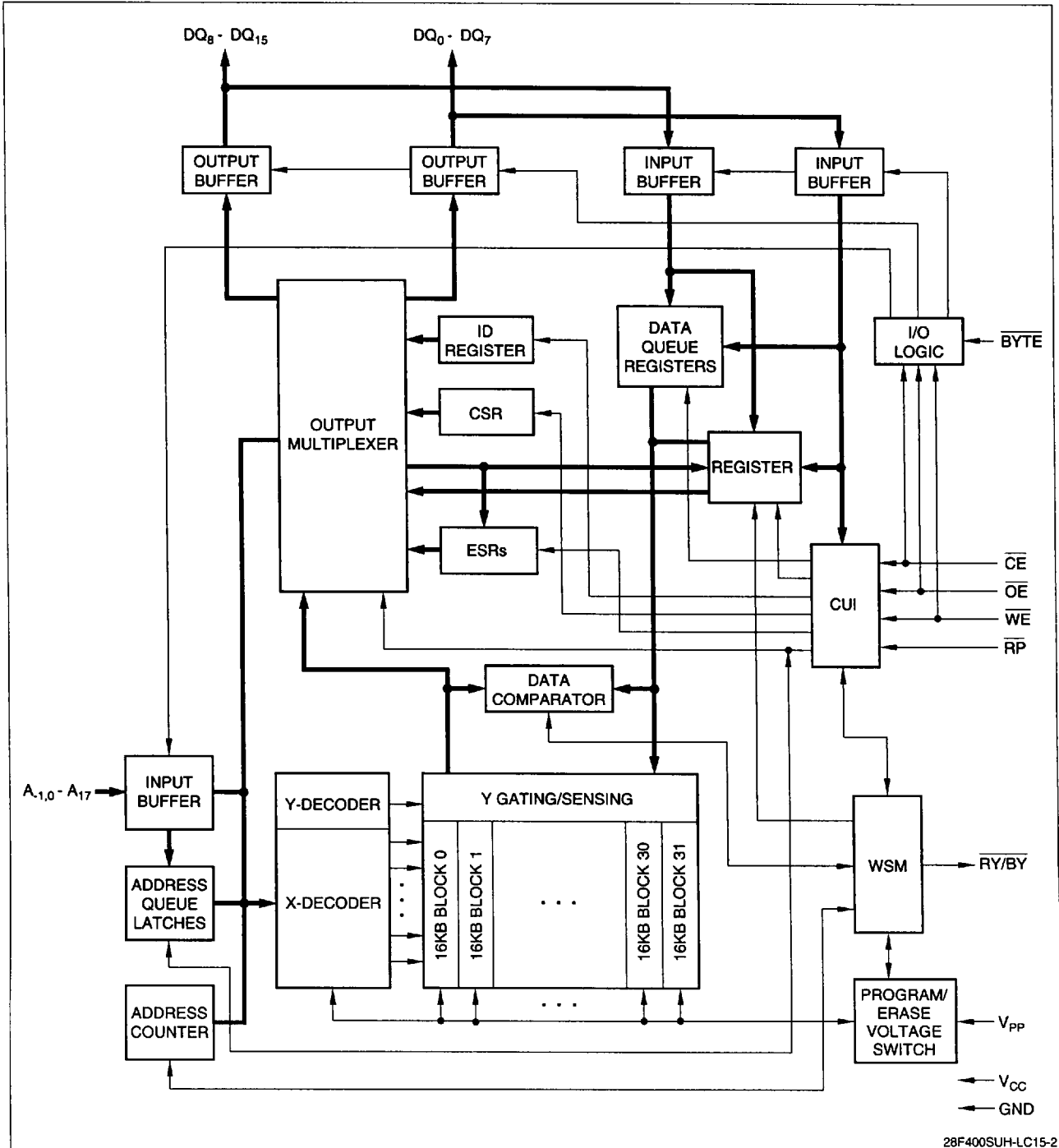

Figure 4. LH28F004SU-LC Block Diagram

PIN DESCRIPTION

SYMBOL	TYPE	NAME AND FUNCTION
DQ ₁₅ - A ₁	INPUT	BYTE-SELECT ADDRESSES: Selects between high and low byte when device is in x8 mode. This address is latched in x8 Data Writes. Not used in x16 mode (i.e., the DQ ₁₅ /A ₁ input buffer is turned off when $\overline{\text{BYTE}}$ is high).
A ₀ - A ₁₂	INPUT	WORD-SELECT ADDRESSES: Select a word within one 16K block. These addresses are latched during Data Writes.
A ₁₃ - A ₁₇	INPUT	BLOCK-SELECT ADDRESSES: Select 1 of 32 Erase blocks. These addresses are latched during Data Writes, Erase and Lock-Block operations.
DQ ₀ - DQ ₇	INPUT/OUTPUT	LOW-BYTE DATA BUS: Inputs data and commands during CUI write cycles. Outputs array, buffer, identifier or status data in the appropriate Read mode. Floated when the chip is de-selected or the outputs are disabled.
DQ ₈ - DQ ₁₅	INPUT/OUTPUT	HIGH-BYTE DATA BUS: Inputs data during x16 Data Write operations. Outputs array, buffer or identifier data in the appropriate Read mode; not used for Status register reads. Floated when the chip is de-selected or the outputs are disabled. DQ ₁₅ /A ₁ is address.
$\overline{\text{CE}}$	INPUT	CHIP ENABLE INPUT: Activate the device's control logic, input buffers, decoders and sense amplifiers. $\overline{\text{CE}}$ must be low to select the device.
$\overline{\text{RP}}$	INPUT	RESET/POWER-DOWN: $\overline{\text{RP}}$ low places the device in a Deep Power-Down state. All circuits that burn static power, even those circuits enabled in standby mode, are turned off. When returning from Deep Power-Down, a recovery time of 750 ns is required to allow these circuits to power-up. When $\overline{\text{RP}}$ goes low, any current or pending WSM operation(s) are terminated, and the device is reset. All Status registers return to ready (with all status flags cleared).
$\overline{\text{OE}}$	INPUT	OUTPUT ENABLE: Gates device data through the output buffers when low. The outputs float to tri-state off when $\overline{\text{OE}}$ is high.
$\overline{\text{WE}}$	INPUT	WRITE ENABLE: Controls access to the CUI, Data Queue Registers and Address Queue Latches. $\overline{\text{WE}}$ is active low, and latches both address and data (command or array) on its rising edge.
$\overline{\text{RY}}/\overline{\text{BY}}$	OPEN DRAIN OUTPUT	READY/BUSY: Indicates status of the internal WSM. When low, it indicates that the WSM is busy performing an operation. When the WSM is ready for new operation or Erase is Suspended, or the device is in deep power-down mode $\overline{\text{RY}}/\overline{\text{BY}}$ pin is floated.
BYTE	INPUT	BYTE ENABLE: $\overline{\text{BYTE}}$ low places device in x8 mode. All data is then input or output on DQ ₀ - DQ ₇ , and DQ ₈ - DQ ₁₅ float. Address A ₁ selects between the high and low byte. $\overline{\text{BYTE}}$ high places the device in x16 mode, and turns off the A ₁ input buffer. Address A ₀ , then becomes the lowest order address.
V _{PP}	SUPPLY	ERASE/WRITE POWER SUPPLY (5.0 V ±0.5 V): For erasing memory array blocks or writing words/bytes into the flash array.
V _{CC}	SUPPLY	DEVICE POWER SUPPLY (3.0 V ±0.3 V): Do not leave any power pins floating.
GND	SUPPLY	GROUND FOR ALL INTERNAL CIRCUITRY: Do not leave any ground pins floating.
NC		NO CONNECT: No internal connection to die, lead may be driven or left floating.

INTRODUCTION

Sharp's LH28F400SU-LC 4M Flash Memory is a revolutionary architecture which enables the design of truly mobile, high performance, personal computing and communication products. With innovative capabilities, 3.3V low power operation and very high read/write performance, the LH28F400SU-LC is also the ideal choice for designing embedded mass storage flash memory systems.

The LH28F400SU-LC's independently lockable 32 symmetrical blocked architecture (16K each) extended cycling, low power operation, very fast write and read performance and selective block locking provide a highly flexible memory component suitable for cellular phone, facsimile, game, PC, printer and handy terminal. The LH28F400SU-LC's 5.0 V/3.3 V power supply operation enables the design of memory cards which can be read in 3.3 V system and written in 5.0 V/3.3 V systems. Its x8/x16 architecture allows the optimization of memory to processor interface. The flexible block locking option enables bundling of executable application software in a Resident Flash Array or memory card. Manufactured on Sharp's 0.55 μm ETOX™ process technology, the LH28F400SU-LC is the most cost-effective, high-density 3.3 V flash memory.

DESCRIPTION

The LH28F400SU-LC is a high performance 4M (4,194,304 bit) block erasable non-volatile random access memory organized as either 256K × 16 or 512K × 8. The LH28F400SU-LC includes thirty-two 16K (16,384) blocks. A chip memory map is shown in Figure 5.

The implementation of a new architecture, with many enhanced features, will improve the device operating characteristics and results in greater product reliability and ease of use.

Among the significant enhancements of the LH28F400SU-LC:

- 3 V Read, 5 V Write/Erase Operation (5 V V_{PP} , 3 V V_{CC})
- Low Power Capability (2.7 V V_{CC} Read)
- Improved Write Performance
- Dedicated Block Write/Erase Protection
- Command-Controlled Memory Protection Set/Reset Capability

A Command User Interface (CUI) serves as the system interface between the microprocessor or microcontroller and the internal memory operation.

Internal Algorithm Automation allows Byte Writes and Block Erase operations to be executed using a Two-Write command sequence to the CUI in the same way as the LH28F008SA 8M Flash memory.

A Superset of commands have been added to the basic LH28F008SA command-set to achieve higher write performance and provide additional capabilities. These new commands and features include:

- Software Locking of Memory Blocks
- Memory Protection Set/Reset Capability
- Two-Byte Serial Writes in 8-bit Systems
- Erase All Unlocked Blocks

Writing of memory data is performed typically within 20 μs per byte. Writing of memory data is performed typically within 30 μs per word. A Block Erase operation erases one of the 32 blocks in typically 0.8 seconds, independent of the other blocks.

LH28F400SU-LC allows to erase all unlocked blocks. It is desirable in case of which you have to implement Erase operation maximum 32 times.

LH28F400SU-LC enable Two-Byte serialWrite which is operated by three times command input. Writing of memory data is performed typically within 30 μs per two-byte. This feature can improve 8-bit system write performance by up to typically 15 μs per byte.

All operations are started by a sequence of Write commands to the device. Status Register (described in detail later) and a RY/BY output pin provide information on the progress of the requested operation.

Same as the LH28F008SA, LH28F400SU-LC requires an operation to complete before the next operation can be requested, also it allows to suspend block erase to read data from any other block, and allow to resume erase operation.

The LH28F400SU-LC provides user-selectable block locking to protect code or data such as Device Drivers, PCMCIA card information, ROM-Executable OS or Application Code. Each block has an associated non-volatile lock-bit which determines the lock status of the block. In addition, the LH28F400SU-LC has a software controlled master Write Protect circuit which prevents any modifications to memory blocks whose lock-bits are set.

When the device power-up or \overline{RP} turns High, Write Protect Set/Confirm command must be written. Otherwise, all lock bits in the device remain being locked, can't perform the Write to each block and single Block Erase. Write Protect Set/Confirm command must be written to reflect the actual lock status. However, when the device power-on or \overline{RP} turns High, Erase All Unlocked Blocks can be used. If used, Erase is performed with reflecting actual lock status, and after that Write and Block Erase can be used.

The LH28F400SU-LC contains a Compatible Status Register (CSR) which is 100% compatible with the LH28F008SA Flash memory's Status Register. This register, when used alone, provides a straightforward upgrade capability to the LH28F400SU-LC from a LH28F008SA-based design.

The LH28F400SU-LC incorporates an open drain $\overline{RY}/\overline{BY}$ output pin. This feature allows the user to OR-tie many $\overline{RY}/\overline{BY}$ pins together in a multiple memory configuration such as a Resident Flash Array.

The LH28F400SU-LC is specified for a maximum access time of 150 ns (t_{ACC}) at 3.3 V operation (3.0 to 3.6 V) over the commercial temperature range. A corresponding maximum access time of 190 ns (t_{ACC}) at 2.7 V (0 to +70°C) is achieved for reduced power consumption applications.

The LH28F400SU-LC incorporates an Automatic Power Saving (APS) feature which substantially reduces the active current when the device is in static mode of operation (addresses not switching).

In APS mode, the typical I_{CC} current is 1 mA at 3.3 V.

A Deep Power-Down mode of operation is invoked when the \overline{RP} (called \overline{PWD} on the LH28F008SA) pin transitions low. This mode brings the device power consumption to less than 8 μ A, and provides additional write protection by acting as a device reset pin during power transitions. A reset time of 750 ns is required from \overline{RP} switching high until outputs are again valid. In the Deep Power-Down state, the WSM is reset (any current operation will abort) and the CSR register is cleared.

A CMOS Standby mode of operation is enabled when \overline{CE} transitions high and \overline{RP} stays high with all input control pins as CMOS levels. In this mode, the device draws an I_{CC} standby current of 15 μ A.

MEMORY MAP

7FFFFH	16KB BLOCK	31
7C000H	16KB BLOCK	30
7BFFFFH	16KB BLOCK	30
78000H	16KB BLOCK	29
77FFFFH	16KB BLOCK	29
74000H	16KB BLOCK	28
73FFFFH	16KB BLOCK	28
70000H	16KB BLOCK	27
6FFFFH	16KB BLOCK	27
6C000H	16KB BLOCK	26
6BFFFFH	16KB BLOCK	26
68000H	16KB BLOCK	25
67FFFFH	16KB BLOCK	25
64000H	16KB BLOCK	24
63FFFFH	16KB BLOCK	24
60000H	16KB BLOCK	23
5FFFFH	16KB BLOCK	23
5C000H	16KB BLOCK	22
5BFFFFH	16KB BLOCK	22
58000H	16KB BLOCK	21
57FFFFH	16KB BLOCK	21
54000H	16KB BLOCK	20
53FFFFH	16KB BLOCK	20
50000H	16KB BLOCK	19
4FFFFH	16KB BLOCK	19
4C000H	16KB BLOCK	18
4BFFFFH	16KB BLOCK	18
48000H	16KB BLOCK	17
47FFFFH	16KB BLOCK	17
44000H	16KB BLOCK	16
43FFFFH	16KB BLOCK	16
40000H	16KB BLOCK	15
3FFFFH	16KB BLOCK	15
3C000H	16KB BLOCK	14
3BFFFFH	16KB BLOCK	14
38000H	16KB BLOCK	13
37FFFFH	16KB BLOCK	13
34000H	16KB BLOCK	12
33FFFFH	16KB BLOCK	12
30000H	16KB BLOCK	11
2FFFFH	16KB BLOCK	11
2C000H	16KB BLOCK	10
2BFFFFH	16KB BLOCK	10
28000H	16KB BLOCK	9
27FFFFH	16KB BLOCK	9
24000H	16KB BLOCK	8
23FFFFH	16KB BLOCK	8
20000H	16KB BLOCK	7
1FFFFH	16KB BLOCK	7
1C000H	16KB BLOCK	6
1BFFFFH	16KB BLOCK	6
18000H	16KB BLOCK	5
17FFFFH	16KB BLOCK	5
14000H	16KB BLOCK	4
13FFFFH	16KB BLOCK	4
10000H	16KB BLOCK	3
0FFFFH	16KB BLOCK	3
0C000H	16KB BLOCK	2
0BFFFFH	16KB BLOCK	2
08000H	16KB BLOCK	1
07FFFFH	16KB BLOCK	1
04000H	16KB BLOCK	0
03FFFFH	16KB BLOCK	0
00000H	16KB BLOCK	0

28F400SUH-LC15-3

Figure 5. Memory Map

BUS OPERATIONS, COMMANDS AND STATUS REGISTER DEFINITIONS

Bus Operations for Word-Wide Mode ($\overline{\text{BYTE}} = V_{\text{IH}}$)

MODE	$\overline{\text{RP}}$	$\overline{\text{CE}}$	$\overline{\text{OE}}$	$\overline{\text{WE}}$	A_0	DQ_{0-15}	$\overline{\text{RY}}/\text{BY}$	NOTE
Read	V_{IH}	V_{IL}	V_{IL}	V_{IH}	X	D_{OUT}	X	1, 2, 7
Output Disable	V_{IH}	V_{IL}	V_{IH}	V_{IH}	X	High-Z	X	1, 6, 7
Standby	V_{IH}	V_{IH}	X	X	X	High-Z	X	1, 6, 7
Deep Power-Down	V_{IL}	X	X	X	X	High-Z	V_{OH}	1, 3
Manufacturer ID	V_{IH}	V_{IL}	V_{IL}	V_{IH}	V_{IL}	00B0H	V_{OH}	4
Device ID	V_{IH}	V_{IL}	V_{IL}	V_{IH}	V_{IH}	ID	V_{OH}	4
Write	V_{IH}	V_{IL}	V_{IH}	V_{IL}	X	D_{IN}	X	1, 5, 6

Bus Operations for Word-Wide Mode ($\overline{\text{BYTE}} = V_{\text{IH}}$)

MODE	$\overline{\text{RP}}$	$\overline{\text{CE}}$	$\overline{\text{OE}}$	$\overline{\text{WE}}$	A_0	DQ_{0-7}	$\overline{\text{RY}}/\text{BY}$	NOTE
Read	V_{IH}	V_{IL}	V_{IL}	V_{IH}	X	D_{OUT}	X	1, 2, 7
Output Disable	V_{IH}	V_{IL}	V_{IH}	V_{IH}	X	High-Z	X	1, 6, 7
Standby	V_{IH}	V_{IH}	X	X	X	High-Z	X	1, 6, 7
Deep Power-Down	V_{IL}	X	X	X	X	High-Z	V_{OH}	1, 3
Manufacturer ID	V_{IH}	V_{IL}	V_{IL}	V_{IH}	V_{IL}	B0H	V_{OH}	4
Device ID	V_{IH}	V_{IL}	V_{IL}	V_{IH}	V_{IH}	ID	V_{OH}	4
Write	V_{IH}	V_{IL}	V_{IH}	V_{IL}	X	D_{IN}	X	1, 5, 6

NOTES:

- X can be V_{IH} or V_{IL} for address or control pins except for $\overline{\text{RY}}/\overline{\text{BY}}$, which is either V_{OL} or V_{OH} .
- $\overline{\text{RY}}/\overline{\text{BY}}$ output is open drain. When the WSM is ready, Erase is suspended or the device is in deep power-down mode, $\overline{\text{RY}}/\overline{\text{BY}}$ will be at V_{OH} if it is tied to V_{CC} through a resistor. When the $\overline{\text{RY}}/\overline{\text{BY}}$ at V_{OL} is independent of $\overline{\text{OE}}$ while a WSM operation is in progress.
- $\overline{\text{RP}}$ at $\text{GND} \pm 0.2 \text{ V}$ ensures the lowest deep power-down current.
- A_0 at V_{IL} provide manufacturer ID codes. A_0 at V_{IH} provide device ID codes. Device ID code = 23H (x8). Device ID Code = 6623H (x16). All other addresses are set to zero.
- Commands for different Erase operations, Data Write Operations, and Lock-Block operations can only be successfully completed when $V_{\text{PP}} = V_{\text{PPH}}$.
- While the WSM is running, $\overline{\text{RY}}/\overline{\text{BY}}$ in Level-Mode (default) stays at V_{OL} until all operations are complete. $\overline{\text{RY}}/\overline{\text{BY}}$ goes to V_{OH} when the WSM is not busy or in erase suspend mode.
- $\overline{\text{RY}}/\overline{\text{BY}}$ may be at V_{OL} while the WSM is busy performing various operations. For example, a status register read during a write operation.

LH28F008SA-Compatible Mode Command Bus Definitions

COMMAND	FIRST BUS CYCLE			SECOND BUS CYCLE			NOTE
	OPER.	ADDRESS	DATA	OPER.	ADDRESS	DATA	
Read Array	Write	X	FFH	Read	AA	AD	
Intelligent Identifier	Write	X	90H	Read	IA	ID	1
Read Compatible Status Register	Write	X	70H	Read	X	CSR.D	2
Clear Status Register	Write	X	50H				3
Word Write	Write	X	40H	Write	WA	WD	
Alternate Word Write	Write	X	10H	Write	WA	WD	
Block Erase/Confirm	Write	X	20H	Write	BA	D0H	4
Erase Suspend/Resume	Write	X	B0H	Write	X	D0H	4

ADDRESS

AA = Array Address
 BA = Block Address
 IA = Identifier Address
 WA = Write Address
 X = Don't Care

DATA

AD = Array Data
 CSR.D = CSR Data
 ID = Identifier Data
 WD = Write Data

NOTES:

- Following the intelligent identifier command, two Read operations access the manufacturer and device signature codes.
- The CSR is automatically available after device enters Data Write, Erase or Suspend operations.
- Clears CSR.3, CSR.4, and CSR.5. See Status register definitions.
- While device performs Block Erase, if you issue Erase Suspend command (B0H), be sure to confirm ESS (Erase-Suspend-Status) is set to 1 on compatible status register. In the case, ESS bit was not set to 1, also completed the Erase (ESS = 0, WSMS = 1), be sure to issue Resume command (D0H) after completed next Erase command. Beside, when the Erase Suspend command is issued, while the device is not in Erase, be sure to issue Resume command (D0H) after the next erase completed.

LH28F400SU-LC Performance Enhancement Command Bus Definitions

COMMAND	MODE	FIRST BUS CYCLE			SECOND BUS CYCLE			THIRD BUS CYCLE			NOTE
		OPER.	ADD.	DATA	OPER.	ADD.	DATA	OPER.	ADD.	DATA	
Protect Set/Confirm		Write	X	57H	Write	0FFH	D0H				1, 2
Protect Reset/Confirm		Write	X	47H	Write	0FFH	D0H				3
Lock Block/Confirm		Write	X	77H	Write	BA	D0H				1, 2, 4
Erase All Unlocked Blocks		Write	X	A7H	Write	X	D0H				1, 2
Two-Byte Write	x8	Write	X	FBH	Write	A1	WD (L, H)	Write	WA	WD (H, L)	1, 2, 5

ADDRESS

BA = Block Address
 WA = Write Address
 X = Don't Care

DATA

AD = Array Data
 WD (L, H) = Write Data (Low, High)
 WD (H, L) = Write Data (High, Low)

NOTES:

- After initial device power-up, or return from deep power-down mode, the block lock status bits default to the locked state independent of the data in the corresponding lock bits. In order to upload the lock bit status, it requires to write Protect Set/Confirm command.
- To reflect the actual lock-bit status, the Protect Set/Confirm command must be written after Lock Block/Confirm command.
- When Protect Reset/Confirm command is written, all blocks can be written and erased regardless of the state of the lock-bits.
- The Lock Block/Confirm command must be written after Protect Reset/Confirm command was written.
- A₁ is automatically complemented to load second byte of data A₁ value determines which WD is supplied first: A₁ = 0 looks at the WDL, A₁ = 1 looks at the WDH. In word-wide (x16) mode A₁ don't care.
- Second bus cycle address of Protect Set/Confirm and Protect Reset/Confirm command is 0FFH. Specifically A₉ - A₈ = 0, A₇ - A₀ = 1, others are don't care.

Compatible Status Register

WSMS	ESS	ES	DWS	VPPS	R	R	R
7	6	5	4	3	2	1	0

<p>CSR.7 = WRITE STATE MACHINE STATUS (WSMS) 1 = Ready 0 = Busy</p> <p>CSR.6 = ERASE-SUSPEND STATUS (ESS) 1 = Erase Suspended 0 = Erase in Progress/Completed</p> <p>CSR.5 = ERASE STATUS (ES) 1 = Error in Block Erasure 0 = Successful Block Erase</p> <p>CSR.4 = DATA-WRITE STATUS (DWS) 1 = Error in Data Write 0 = Data Write Successful</p> <p>CSR.3 = V_{PP} STATUS (VPPS) 1 = V_{PP} Low Detect, Operation Abort 0 = V_{PP} OK</p>	<p>NOTES:</p> <ol style="list-style-type: none"> RY/BY output or WSMS bit must be checked to determine completion of an operation (Erase Suspend, Erase or Data Write) before the appropriate Status bit (ESS, ES or DWS) is checked for success. If DWS and ES are set to '1' during an erase attempt, an improper command sequence was entered. Clear the CSR and attempt the operation again. The VPPS bit, unlike an A/D converter, does not provide continuous indication of V_{PP} level. The WSM interrogates V_{PP}'s level only after the Data-Write or Erase command sequences have been entered, and informs the system if V_{PP} has not been switched on. VPPS is not guaranteed to report accurate feedback between V_{DDL} and V_{PPH}. CSR.2 - CSR.0 = Reserved for further enhancements. These bits are reserved for future use and should be masked out when polling the CSR.
--	--

4M FLASH MEMORY SOFTWARE ALGORITHMS

OVERVIEW

With the advanced Command User Interface, its Performance Enhancement commands and Status Registers, the software code required to perform a given operation may become more intensive but it will result in much higher write/erase performance compared with current flash memory architectures.

The software flowcharts describing how a given operation proceeds are shown here. Figures 6 through 8 depict flowcharts using the 2nd generation flash device in the LH28F008SA-compatible mode. Figures 9 through 15 depict flowcharts using the 2nd generation flash device's performance enhancement commands mode.

When the device power-up or the device is reset by \overline{RP} pin, all blocks come up locked. Therefore, Word/Byte Write, Two Byte Serial Write and Block Erase can not be performed in each block. However, at that time, Erase All Unlocked Block is performed normally, if used, and reflect actual lock status, also the unlocked block data is erased. When the device power-up or the device is reset by RP pin, Set Write Protect command must be written to reflect actual block lock status.

Reset Write Protect command must be written before Write Block Lock command. To reflect actual block lock status, Set Write Protect command is succeeded.

The Compatible Status Register (CSR) is used to determine which blocks are locked. In order to see Lock Status of a certain block, a Word/Byte Write command (WA = Block Address, WD = FFH) is written to the CUI, after issuing Set Write Protect command. If CSR.7, CSR.5 and CSR.4 (WSMS, ES and DWS) are set to '1's, the block is locked. If CSR.7 is set to '1', the block is not locked.

Reset Write Protect command enables Write/Erase operation to each block.

In the case of Block Erase is performed, the block lock information is also erased. Block Lock command and Set Write Protect command must be written to prohibit Write/Erase operation to each block.

There are unassigned commands. It is not recommended that the customer use any command other than the valid commands specified in "Command Bus Definitions". Sharp reserved the right to redefine these codes for future functions.

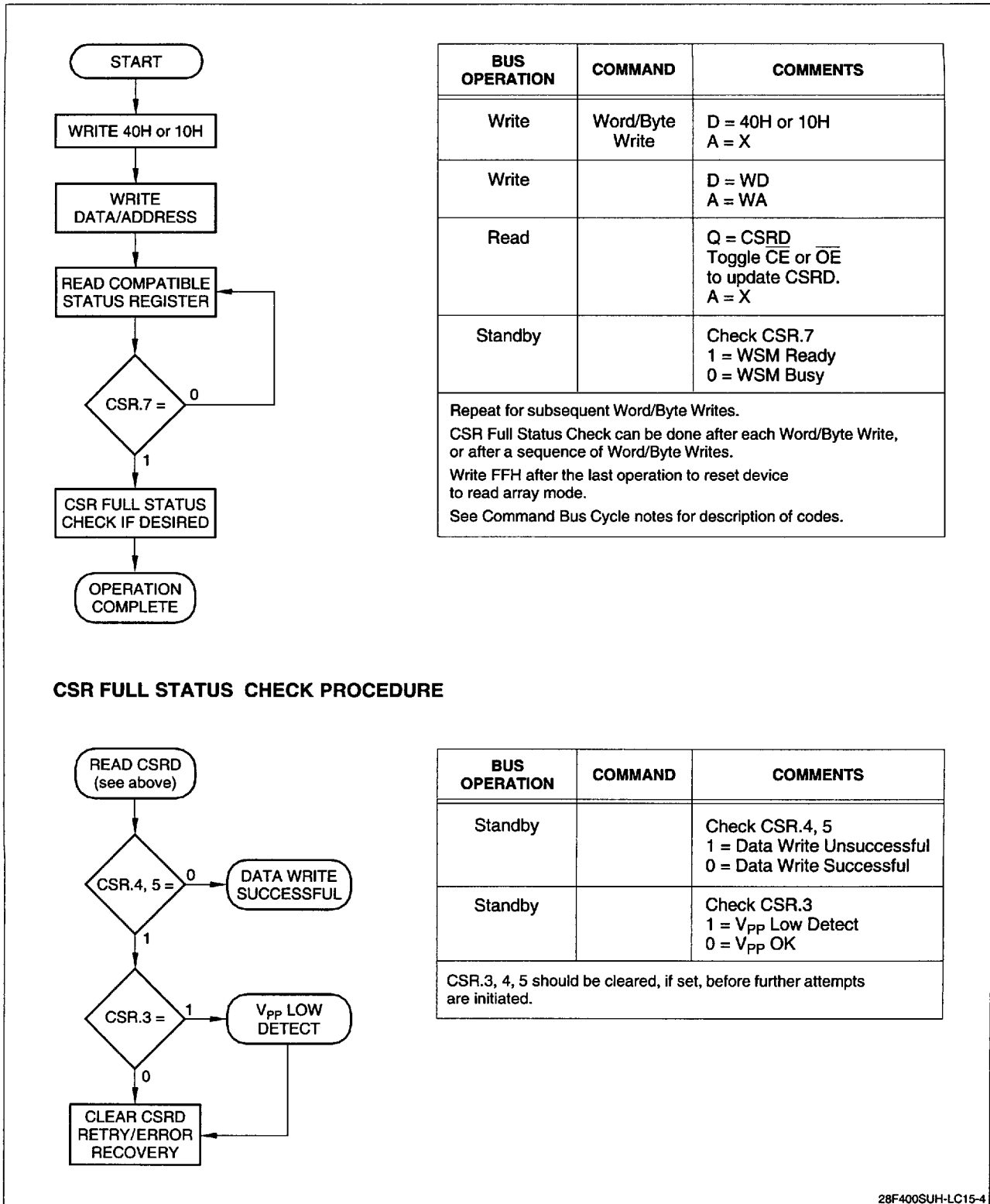
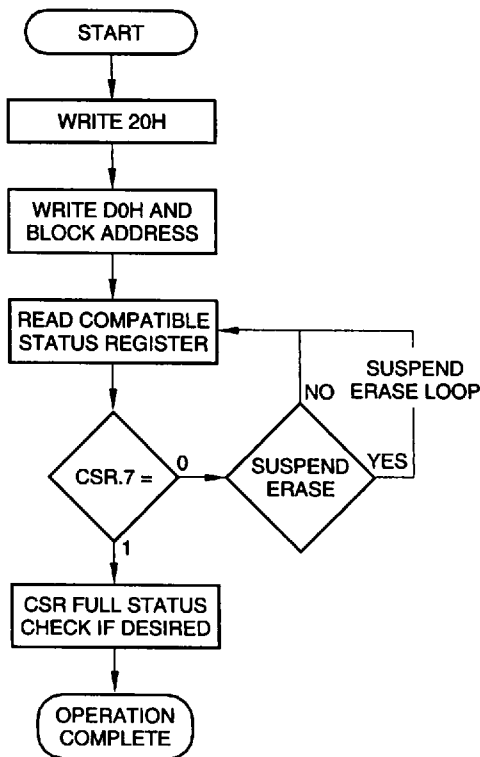

Figure 6. Word/Byte Writes with Compatible Status Register

28F400SUH-LC15-4



BUS OPERATION	COMMAND	COMMENTS
Write	Block Erase	D = 20H A = X
Write	Confirm	D = D0H A = BA
Read		Q = CSRD Toggle \overline{CE} or \overline{OE} to update CSRD. A = X
Standby		Check CSR.7 1 = WSM Ready 0 = WSM Busy

Repeat for subsequent Block Erasures.
 CSR Full Status Check can be done after each Block Erase, or after a sequence of Block Erasures.
 Write FFH after the last operation to reset device to read array mode.
 See Command Bus Cycle notes for description of codes.

CSR FULL STATUS CHECK PROCEDURE

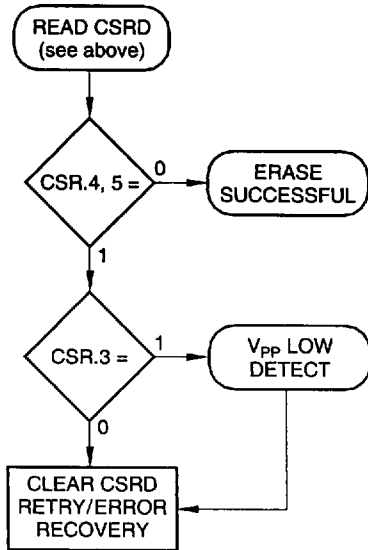

BUS OPERATION	COMMAND	COMMENTS
Standby		Check CSR.4, 5 1 = Erase Error 0 = Erase Successful Both 1 = Command Sequence Error
Standby		Check CSR.3 1 = V _{pp} Low Detect 0 = V _{pp} OK

CSR.3, 4, 5 should be cleared, if set, before further attempts are initiated.

28F400SUH-LC15-5

Figure 7. Block Erase with Compatible Status Register

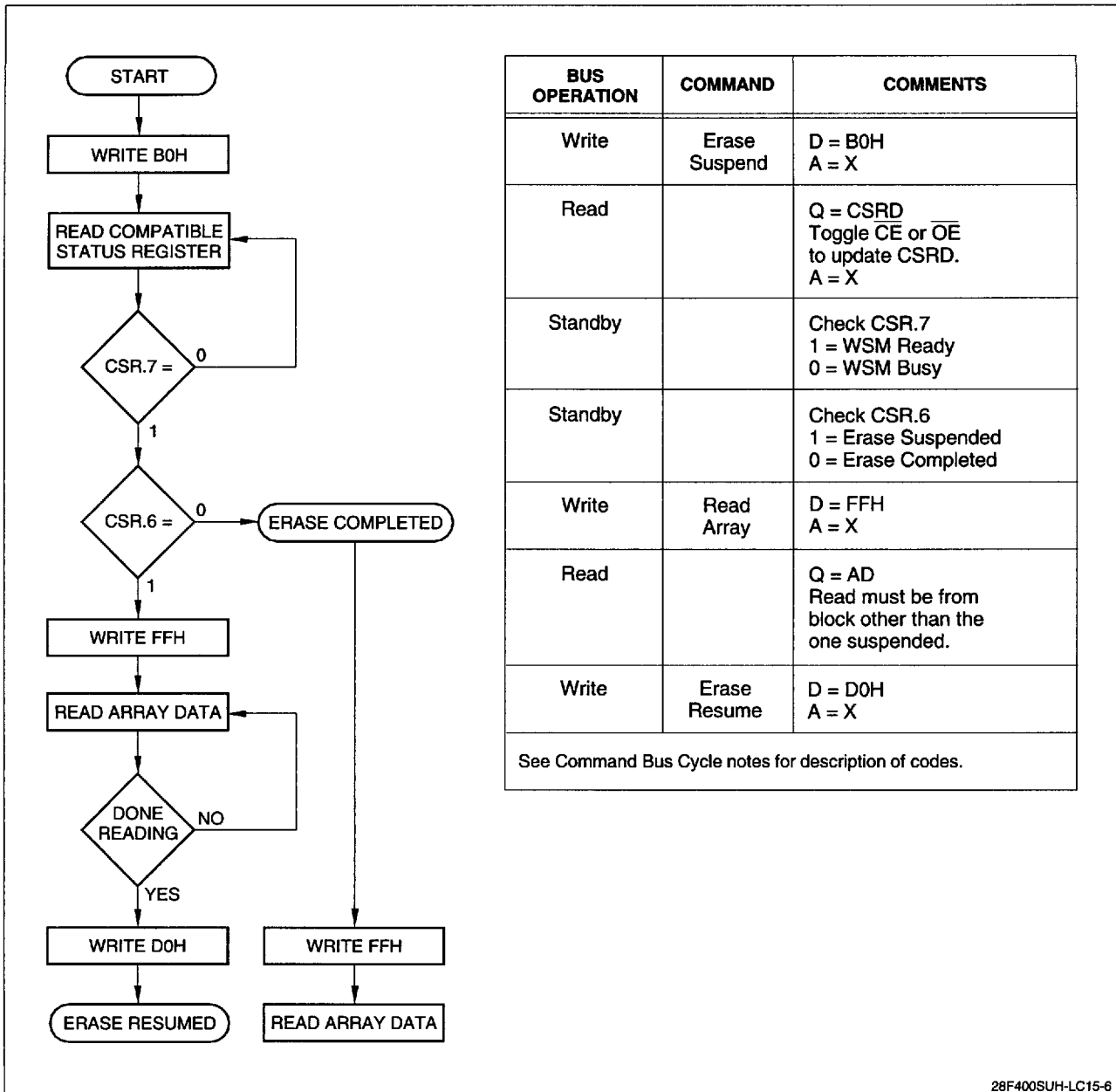

Figure 8. Erase Suspend to Read Array with Compatible Status Register

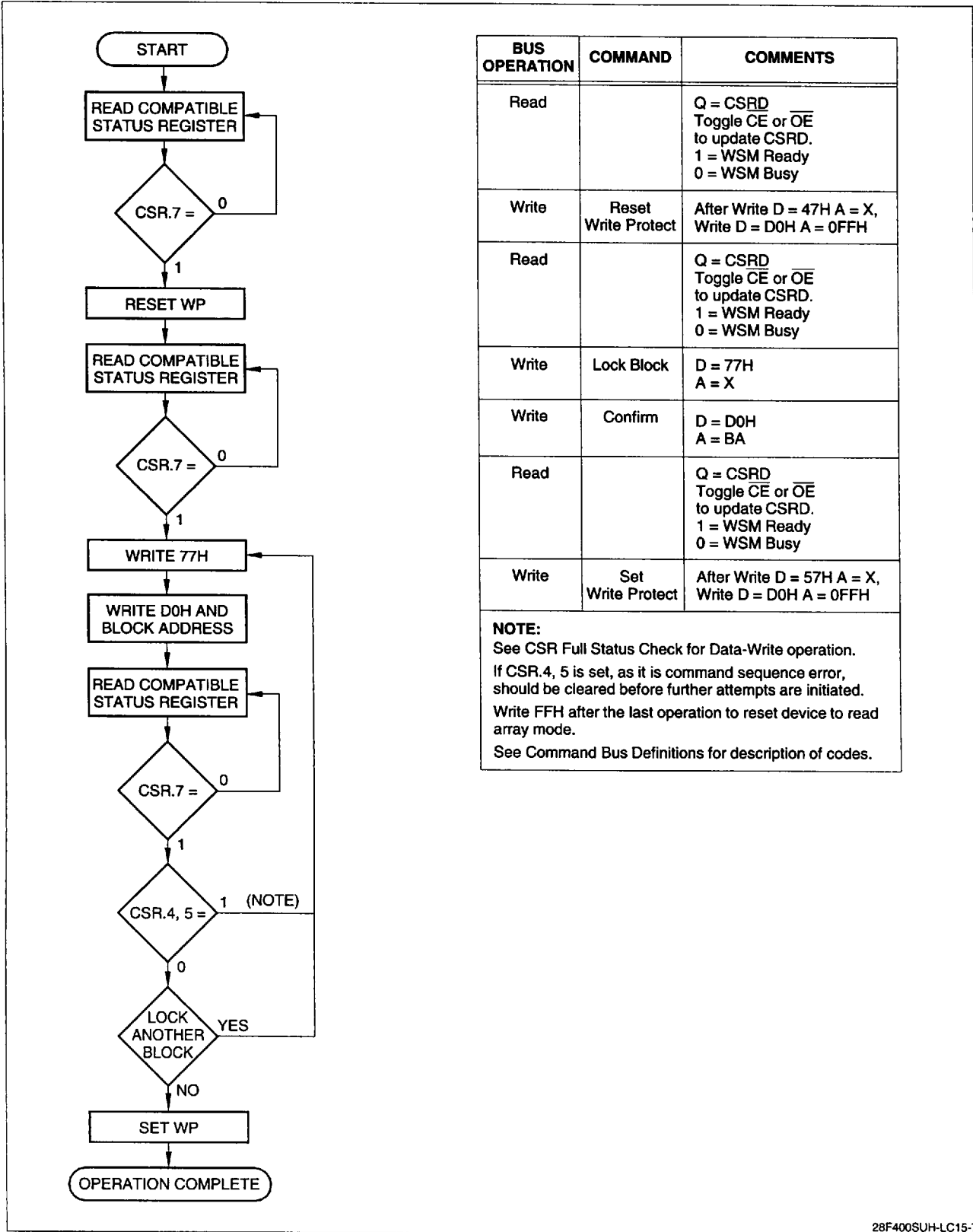

Figure 9. Block Locking Scheme

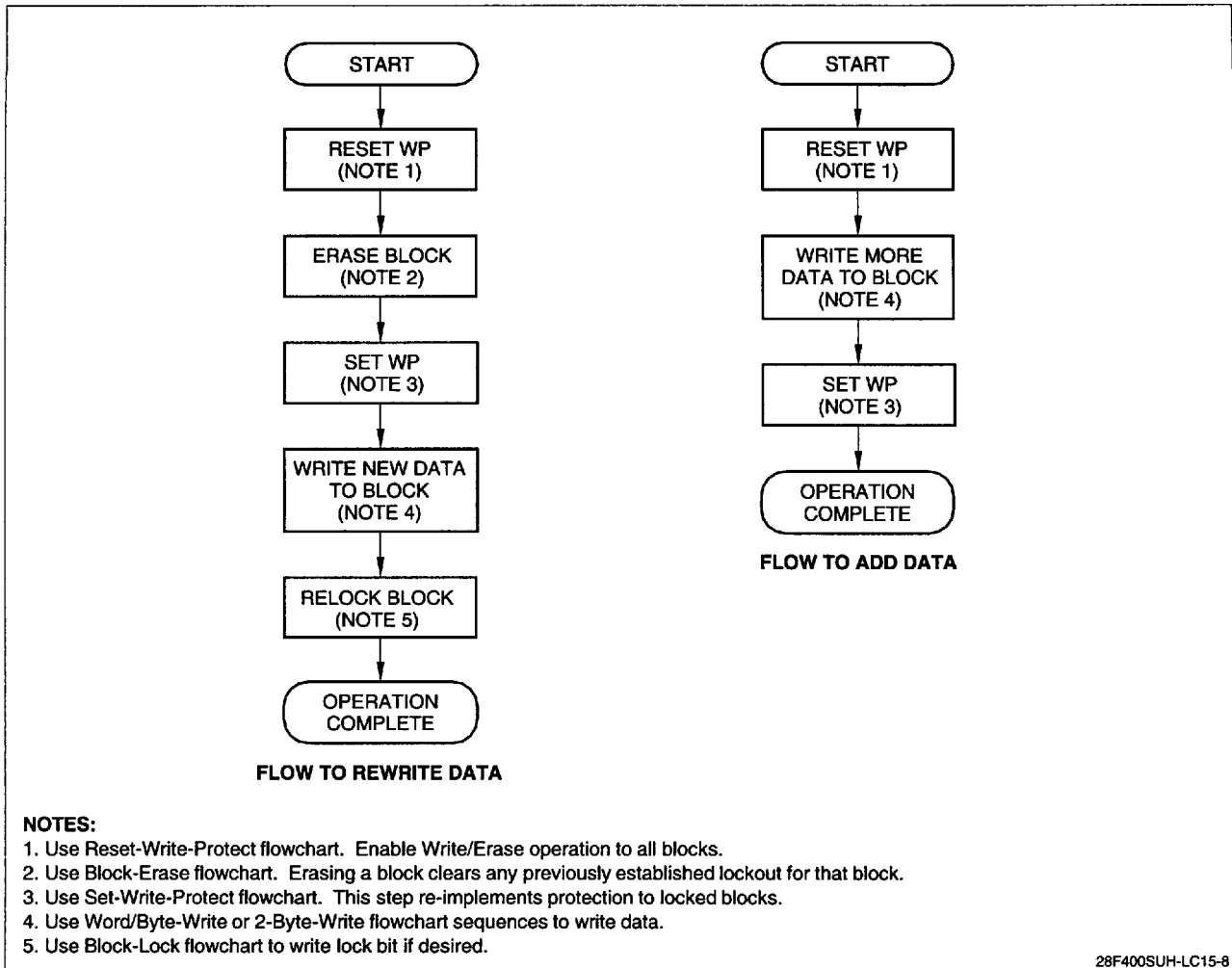
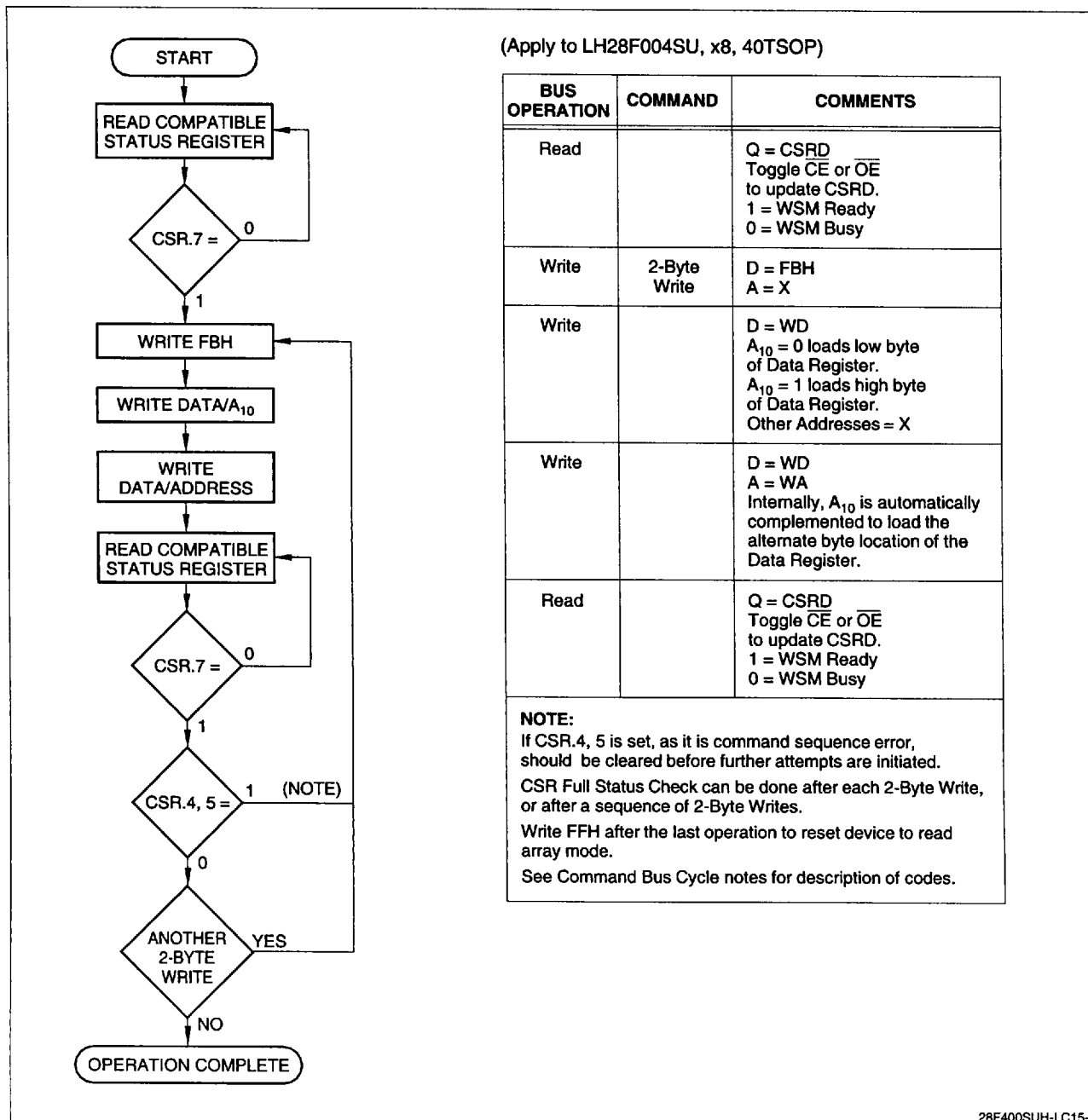

Figure 10. Updating Data in a Locked Block



28F400SUH-LC15-9

Figure 11. Two-Byte SerialWrites with Compatible Status Registers (40-pin TSOP)

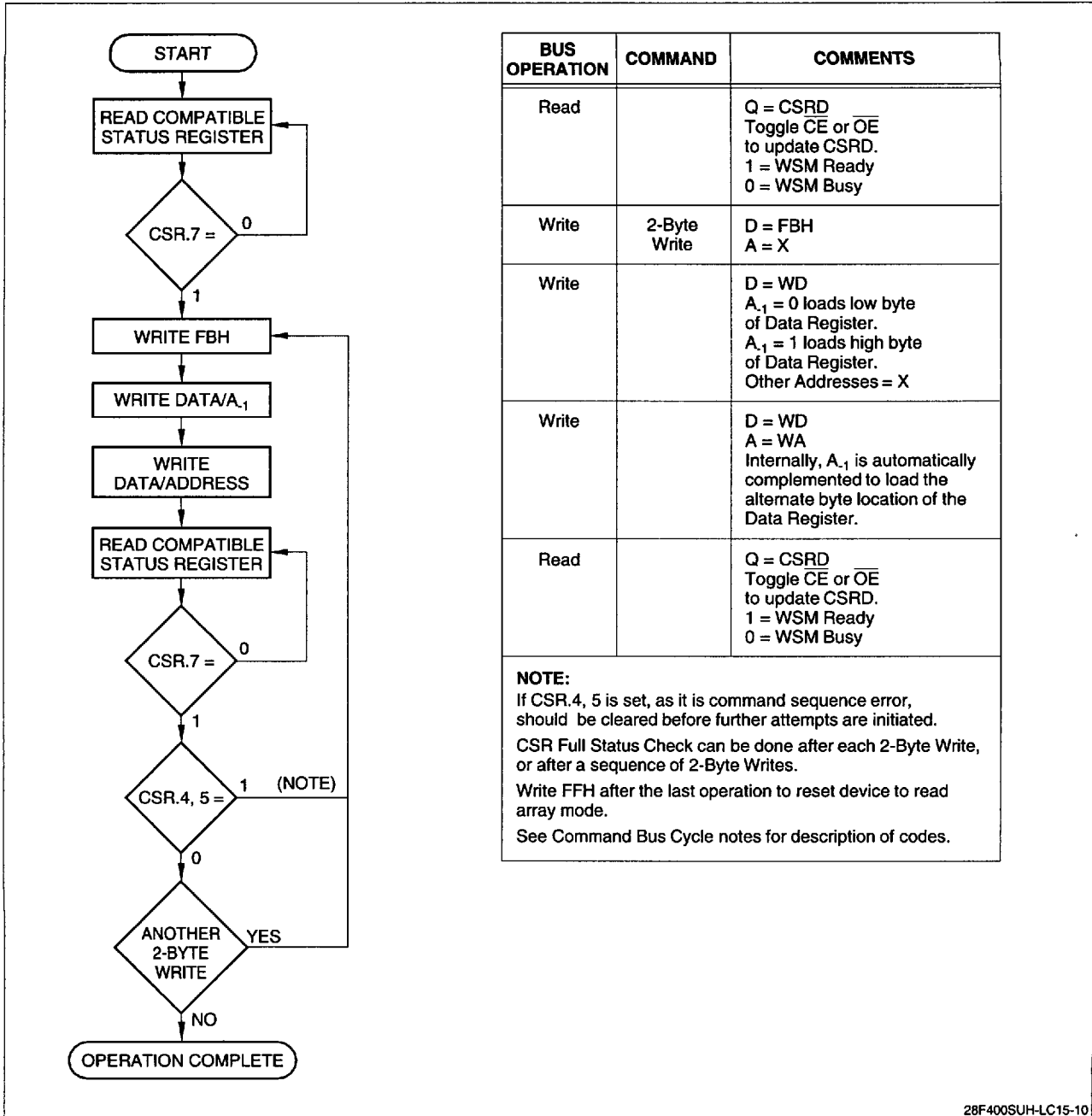
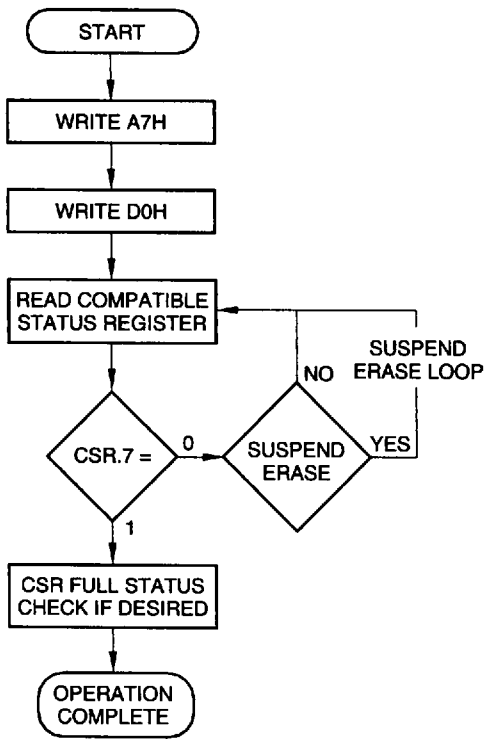

Figure 12. Two-Byte Serial Writes with Compatible Status Registers (56-pin TSOP, 44-pin SOP)



BUS OPERATION	COMMAND	COMMENTS
Write	Erase All Unlocked Blocks	D = A7H A = X
Write	Confirm	D = D0H A = X
Read		Q = CSRD Toggle \overline{CE} or \overline{OE} to update CSRD A = X
Standby		Check CSR.7 1 = WSM Ready 0 = WSM Busy

CSR Full Status Check can be done after Erase All Unlocked Block, or after a sequence of Erasures.
Write FFH after the last operation to reset device to read array mode.
See Command Bus Cycle notes for description of codes.

CSR FULL STATUS CHECK PROCEDURE

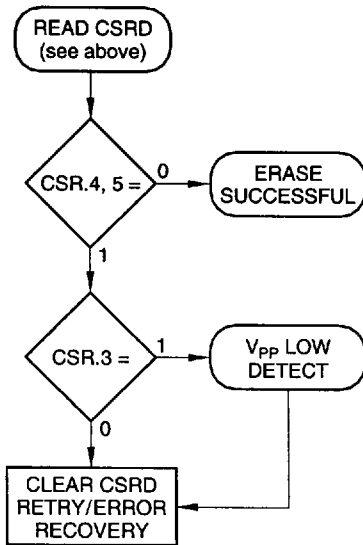

BUS OPERATION	COMMAND	COMMENTS
Standby		Check CSR.4, 5 1 = Erase Error 0 = Erase Successful Both 1 = Command Sequence Error
Standby		Check CSR.3 1 = V _{PP} Low Detect 0 = V _{PP} OK

CSR.3, 4, 5 should be cleared, if set, before further attempts are initiated.

28F400SUH-LC15-11

Figure 13. Erase All Unlocked Blocks with Compatible Status Registers

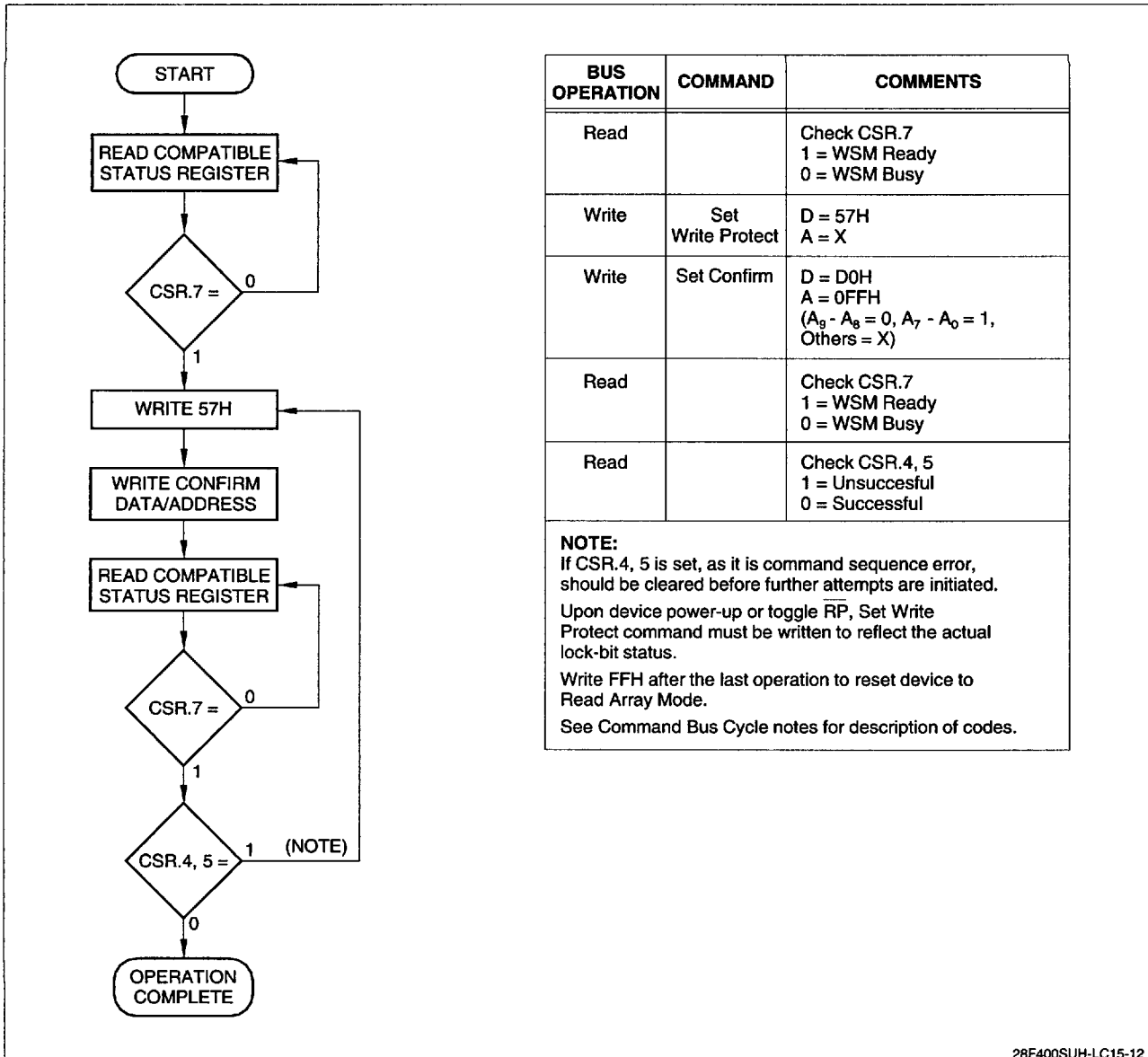

Figure 14. Set Write Protect

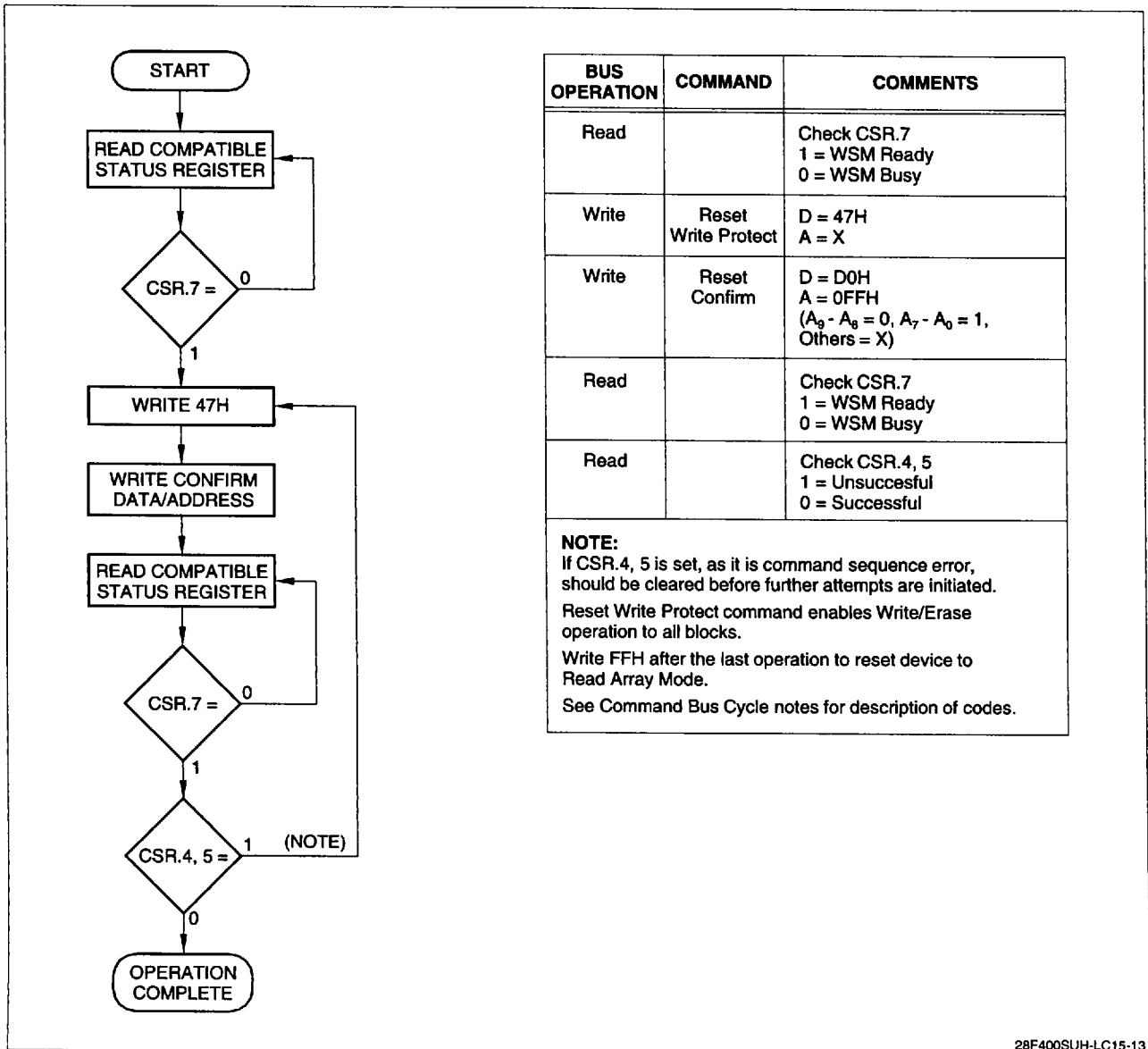

Figure 15. Reset Write Protect

ELECTRICAL SPECIFICATIONS**Absolute Maximum Ratings***

Temperature under bias 0°C to +70°C

Storage temperature -65°C to +125°C

**WARNING: Stressing the device beyond the "Absolute Maximum Ratings" may cause permanent damage. These are stress ratings only. Operation beyond the "Operating Conditions" is not recommended and extended exposure beyond the "Operating Conditions" may affect device reliability.*

V_{CC} = 3.3 V ± 0.3 V Systems

SYMBOL	PARAMETER	MIN.	MAX.	UNITS	TEST CONDITIONS	NOTE
T _A	Operating Temperature, Commercial	0	70	°C	Ambient Temperature	1
V _{CC}	V _{CC} with Respect to GND	-0.2	7.0	V		2
V _{PP}	V _{PP} Supply Voltage with Respect to GND	-0.2	7.0	V		2
V	Voltage on any Pin (Except V _{CC} , V _{PP}) with Respect to GND	-0.5	V _{CC} + 0.5	V		2
I	Current into any Non-Supply Pin		±30	mA		
I _{OUT}	Output Short Circuit Current		100.0	mA		3

NOTES:

- Operating temperature is for commercial product defined by this specification.
- Minimum DC voltage is -0.5 V on input/output pins. During transitions, this level may undershoot to -2.0 V for periods < 20 ns. Maximum DC voltage on input/output pins is V_{CC} + 0.5 V which, during transitions, may overshoot to V_{CC} + 2.0 V for periods < 20 ns.
- Output shorted for no more than one second. No more than one output shorted at a time.

Capacitance**For a 3.3 V Systems**

SYMBOL	PARAMETER	TYP.	MAX.	UNITS	TEST CONDITIONS	NOTE
C _{IN}	Capacitance Looking into an Address/Control Pin	7	10	pF	T _A = 25°C, f = 1.0 MHz	1
	Capacitance Looking into an Address/Control Pin A ₁	9	12	pF	T _A = 25°C, f = 1.0 MHz	1
C _{OUT}	Capacitance Looking into an Output Pin	9	12	pF	T _A = 25°C, f = 1.0 MHz	1
C _{LOAD}	Load Capacitance Driven by Outputs for Timing Specifications		50	pF	For V _{CC} = 3.3 V ± 0.3 V	1
	Equivalent Testing Load Circuit V _{CC} ± 10%		2.5	ns	50 Ω transmission line delay	

NOTE:

- Sampled, not 100% tested.

Timing Nomenclature

For 3.3 V systems use 1.5 V cross point definitions.

Each timing parameter consists of 5 characters. Some common examples are defined below:

- t_{CE} t_{ELQV} time (t) from \overline{CE} (E) going low (L) to the outputs (Q) becoming valid (V)
- t_{OE} t_{GLQV} time (t) from \overline{OE} (G) going low (L) to the outputs (Q) becoming valid (V)
- t_{ACC} t_{AVQV} time (t) from address (A) valid (V) to the outputs (Q) becoming valid (V)
- t_{AS} t_{AVWH} time (t) from address (A) valid (V) to \overline{WE} (W) going high (H)
- t_{DH} t_{WHDx} time (t) from \overline{WE} (W) going high (H) to when the data (D) can become undefined (X)

	PIN CHARACTERS		PIN STATES
A	Address Inputs	H	High
D	Data Inputs	L	Low
Q	Data Outputs	V	Valid
E	\overline{CE} (Chip Enable)	X	Driven, but not necessarily valid
G	\overline{OE} (Output Enable)	Z	High Impedance
W	\overline{WE} (Write Enable)		
P	\overline{RP} (Deep Power-Down Pin)		
R	$\overline{RY}/\overline{BY}$ (Ready/Busy)		
V	Any Voltage Level		
3 V	V_{CC} at 3.0 V Min.		

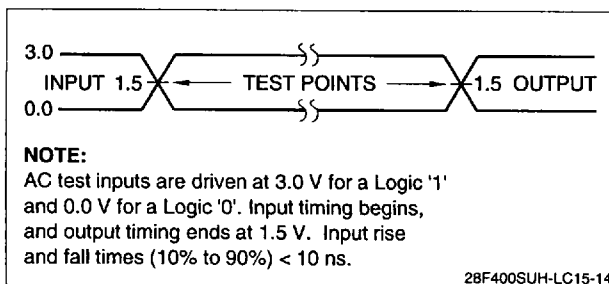

Figure 16. Transient Input/Output Reference Waveform ($V_{CC} = 3.3$ V)

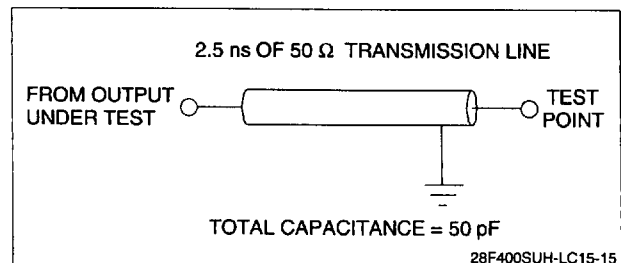

Figure 17. Transient Equivalent Testing Load Circuit ($V_{CC} = 3.3$ V)

DC Characteristics

$$V_{CC} = 3.3 \text{ V} \pm 0.3 \text{ V}, T_A = 0^\circ\text{C to } +70^\circ\text{C}$$

SYMBOL	PARAMETER	TYP.	MIN.	MAX.	UNITS	TEST CONDITIONS	NOTE
I_{IL}	Input Load Current			±1	μA	$V_{CC} = V_{CC \text{ MAX.}}, V_{IN} = V_{CC} \text{ or GND}$	1
I_{LO}	Output Leakage Current			±10	μA	$V_{CC} = V_{CC \text{ MAX.}}, V_{IN} = V_{CC} \text{ or GND}$	1
I_{CCS}	V_{CC} Standby Current	4		15	μA	$V_{CC} = V_{CC \text{ MAX.}},$ $\overline{CE}, \overline{RP} = V_{CC} \pm 0.2 \text{ V}$ $\overline{BYTE} = V_{CC} \pm 0.2 \text{ V or GND} \pm 0.2 \text{ V}$	1, 4
		0.3		4	mA	$V_{CC} = V_{CC \text{ MAX.}},$ $\overline{CE}, \overline{RP} = V_{IH}$ $\overline{BYTE} = V_{IH} \text{ or } V_{IL}$	
I_{CCD}	V_{CC} Deep Power-Down Current	0.2		8	μA	$\overline{RP} = \text{GND} \pm 0.2 \text{ V}$	1
I_{CCR}^1	V_{CC} Read Current			35	mA	$V_{CC} = V_{CC \text{ MAX.}},$ CMOS: $\overline{CE} = \text{GND} \pm 0.2 \text{ V}$ $\overline{BYTE} = \text{GND} \pm 0.2 \text{ V or } V_{CC} \pm 0.2 \text{ V}$ Inputs = $\text{GND} \pm 0.2 \text{ V or } V_{CC} \pm 0.2 \text{ V},$ TTL: $\overline{CE} = V_{IL},$ $\overline{BYTE} = V_{IL} \text{ or } V_{IH}$ Inputs = $V_{IL} \text{ or } V_{IH},$ $f = 8 \text{ MHz}, I_{OUT} = 0 \text{ mA}$	1, 3, 4
I_{CCR}^2	V_{CC} Read Current	10		20	mA	$V_{CC} = V_{CC \text{ MAX.}},$ CMOS: $\overline{CE} = \text{GND} \pm 0.2 \text{ V}$ $\overline{BYTE} = \text{GND} \pm 0.2 \text{ V or } V_{CC} \pm 0.2 \text{ V}$ Inputs = $\text{GND} \pm 0.2 \text{ V or } V_{CC} \pm 0.2 \text{ V},$ TTL: $\overline{CE} = V_{IL},$ $\overline{BYTE} = V_{IH} \text{ or } V_{IL}$ Inputs = $V_{IL} \text{ or } V_{IH},$ $f = 4 \text{ MHz}, I_{OUT} = 0 \text{ mA}$	1, 3, 4
I_{CCW}	V_{CC} Write Current	8		16	mA	Word/Byte Write in Progress	1
I_{CCE}	V_{CC} Block Erase Current	6		12	mA	Block Erase in Progress	1
I_{CCES}	V_{CC} Erase Suspend Current	3		6	mA	$\overline{CE} = V_{IH}$ Block Erase Suspended	1, 2
I_{PPS}	V_{PP} Standby Current	±1		±10	μA	$V_{PP} \leq V_{CC}$	1
I_{PPD}	V_{PP} Deep Power-Down Current	0.2		8	μA	$\overline{RP} = \text{GND} \pm 0.2 \text{ V}$	1

DC Characteristics (Continued)

$$V_{CC} = 3.3 \text{ V} \pm 0.3 \text{ V}, T_A = 0^\circ\text{C to } +70^\circ\text{C}$$

SYMBOL	PARAMETER	TYPE	MIN.	MAX.	UNITS	TEST CONDITIONS	NOTE
I_{PPR}	V_{PP} Read Current			200	μA	$V_{PP} > V_{CC}$	1
I_{PPW}	V_{PP} Write Current	15		35	mA	$V_{PP} = V_{PPH}$, Word/Byte Write in Progress	1
I_{PPE}	V_{PP} Erase Current	20		40	mA	$V_{PP} = V_{PPH}$, Block Erase in Progress	1
I_{PPES}	V_{PP} Erase Suspend Current			200	μA	$V_{PP} = V_{PPH}$, Block Erase Suspended	1
V_{IL}	Input Low Voltage		-0.3	0.8	V		5
V_{IH}	Input High Voltage		2.0	$V_{CC} + 0.3$	V		
V_{OL}	Output Low Voltage			0.4	V	$V_{CC} = V_{CC \text{ MIN.}}$ and $I_{OL} = 4 \text{ mA}$	
V_{OH}^1	Output High Voltage		2.4		V	$I_{OL} = -2 \text{ mA}$ $V_{CC} = V_{CC \text{ MIN.}}$	
V_{OH}^2			$V_{CC} - 0.2$		V	$I_{OL} = 100 \mu\text{A}$ $V_{CC} = V_{CC \text{ MIN.}}$	
V_{PPL}	V_{PP} during Normal Operations		0.0	5.5	V		6
V_{PPH}	V_{PP} during Write/Erase Operations	5.0	4.5	5.5	V		
V_{LKO}	V_{CC} Erase/Write Lock Voltage		1.4		V		

NOTES:

- All currents are in RMS unless otherwise noted. Typical values at $V_{CC} = 3.3 \text{ V}$, $V_{PP} = 5.0 \text{ V}$, $T = 25^\circ\text{C}$. These currents are valid for all product versions (package and speeds).
- I_{CCES} is specified with the device de-selected. If the device is read while in erase suspend mode, current draw is the sum of I_{CCES} and I_{CCR} .
- Automatic Power Saving (APS) reduces I_{CCR} to less than 2 mA in Static operation.
- CMOS inputs are either $V_{CC} \pm 0.2 \text{ V}$ or $\text{GND} \pm 0.2 \text{ V}$. TTL Inputs are either V_{IL} or V_{IH} .
- In $2.7 \text{ V} < V_{CC} < 3.0 \text{ V}$ operation, TTL-level input of $\overline{\text{RP}}$ is $V_{IL} (\text{MAX.}) = 0.6 \text{ V}$.
- V_{PPL} in read is $V_{CC} - 0.2 \text{ V} < V_{PPL} < 5.5 \text{ V}$ or $\text{GND} < V_{PPL} < \text{GND} + 0.2 \text{ V}$.

AC Characteristics - Read Only Operations¹

$$V_{CC} = 3.3V \pm 0.3V, T_A = 0^\circ\text{C to } +70^\circ\text{C}$$

SYMBOL	PARAMETER	MIN.	MAX.	UNITS	NOTE
t_{AVAV}	Read Cycle Time	150		ns	
t_{AVGL}	Address Setup to \overline{OE} Going Low	0		ns	3
t_{AVQV}	Address to Output Delay		150	ns	
t_{ELQV}	\overline{CE} to Output Delay		150	ns	2
t_{PHQV}	\overline{RP} High to Output Delay		750	ns	
t_{GLQV}	\overline{OE} to Output Delay		50	ns	2
t_{ELQX}	\overline{CE} to Output in Low Z	0		ns	3
t_{EHQZ}	\overline{CE} to Output in High Z		55	ns	3
t_{GLQX}	\overline{OE} to Output in Low Z	0		ns	3
t_{GHQZ}	\overline{OE} to Output in High Z		40	ns	3
t_{OH}	Output Hold from Address, \overline{CE} or \overline{OE} change, whichever occurs first	0		ns	3
t_{FLGZ}	\overline{BYTE} Low to Output in High Z		60	ns	3
t_{FLEL} t_{FHEL}	\overline{BYTE} High or Low to \overline{CE} Low	20		ns	3

NOTES:

1. See AC Input/Output Reference Waveforms for timing measurements.
2. \overline{OE} may be delayed up to $t_{ELQV} - t_{GLQV}$ after the falling edge of \overline{CE} without impact on t_{ELQV} .
3. Sampled, not 100% tested.

AC Characteristics - Read Only Operations¹ (Continued)

$$V_{CC} = 2.85 \text{ V} \pm 0.15 \text{ V}, T_A = 0^\circ\text{C to } +70^\circ\text{C}$$

SYMBOL	PARAMETER	MIN.	MAX.	UNITS	NOTE
t_{AVAV}	Read Cycle Time	190		ns	
t_{AVGL}	Address Setup to \overline{OE} Going Low	0		ns	3
t_{AVQV}	Address to Output Delay		190	ns	
t_{ELQV}	\overline{CE} to Output Delay		190	ns	2
t_{PHQV}	\overline{RP} High to Output Delay		900	ns	
t_{GLQV}	\overline{OE} to Output Delay		65	ns	2
t_{ELQX}	\overline{CE} to Output in Low Z	0		ns	3
t_{EHQZ}	\overline{CE} to Output in High Z		70	ns	3
t_{GLQX}	\overline{OE} to Output in Low Z	0		ns	3
t_{GHQZ}	\overline{OE} to Output in High Z		55	ns	3
t_{OH}	Output Hold from Address, \overline{CE} or \overline{OE} change, whichever occurs first	0		ns	3
t_{FLGZ}	\overline{BYTE} Low to Output in High Z		85	ns	3
t_{FLEL} t_{FHEL}	\overline{BYTE} High or Low to \overline{CE} Low	30		ns	3

NOTES:

1. See AC Input/Output Reference Waveforms for timing measurements.
2. \overline{OE} may be delayed up to $t_{ELQV} - t_{GLQV}$ after the falling edge of \overline{CE} without impact on t_{ELQV} .
3. Sampled, not 100% tested.

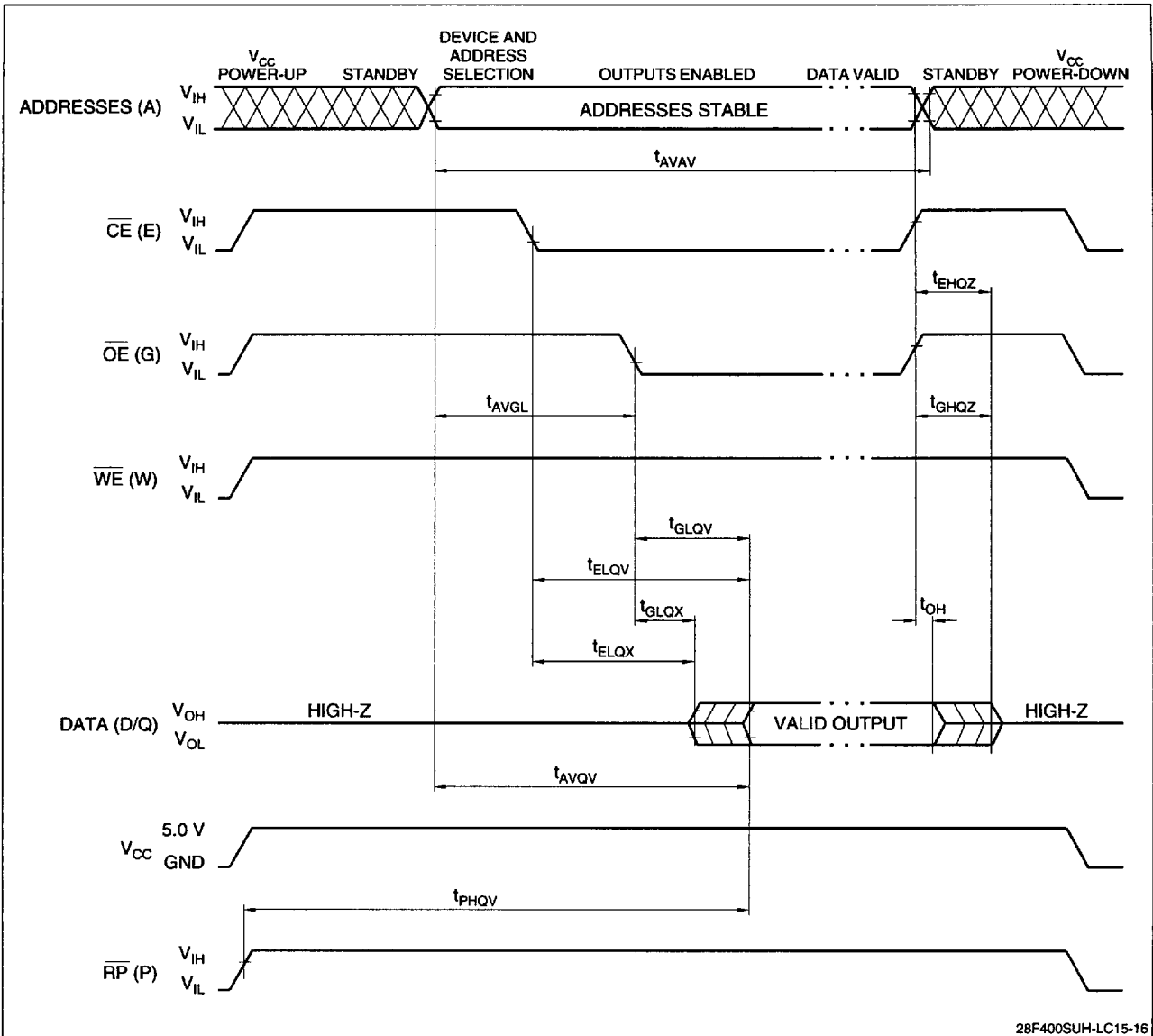
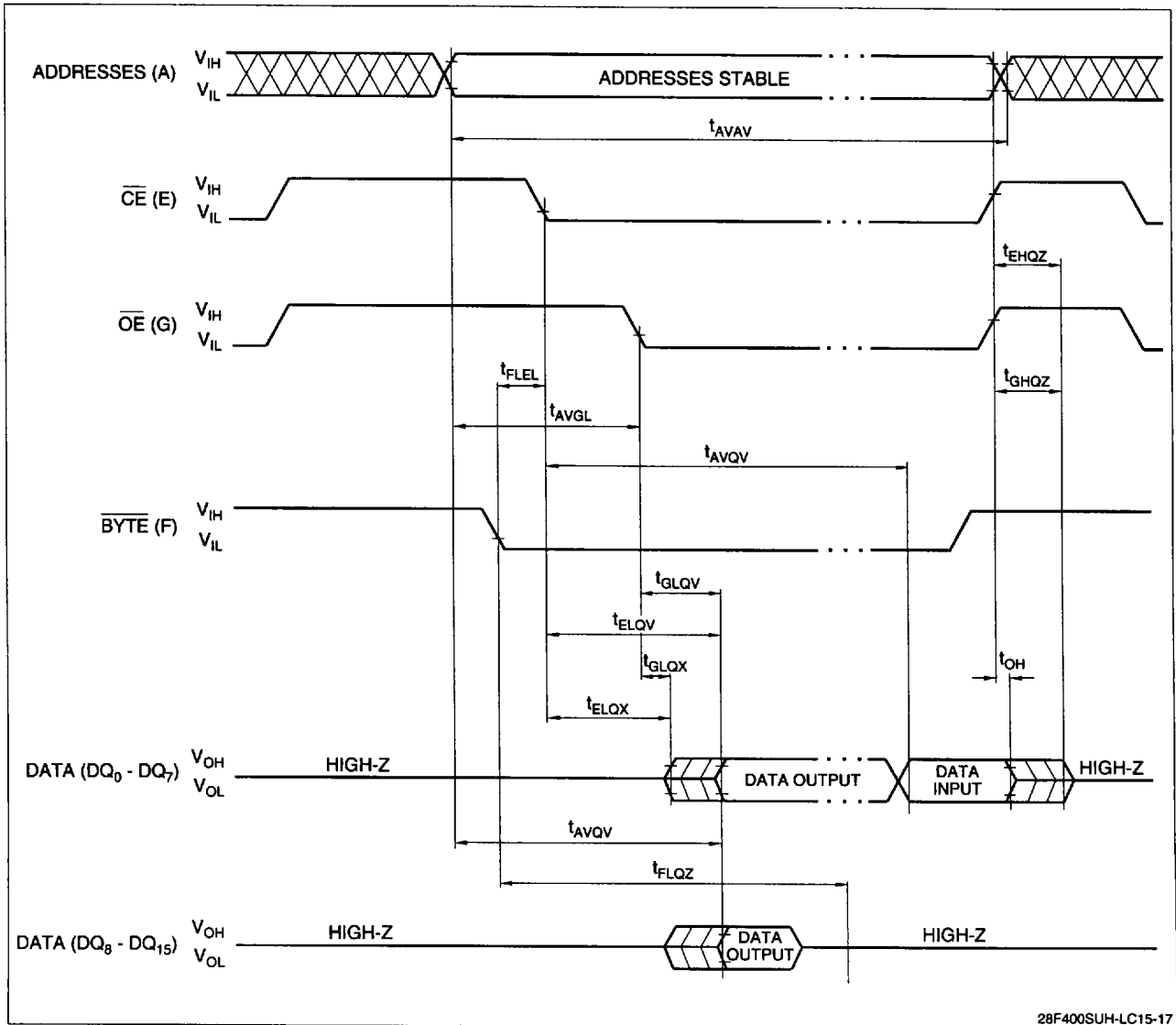

Figure 18. Read Timing Waveforms



28F400SUH-LC15-17

Figure 19. \overline{BYTE} Timing Waveforms

POWER-UP AND RESET TIMINGS

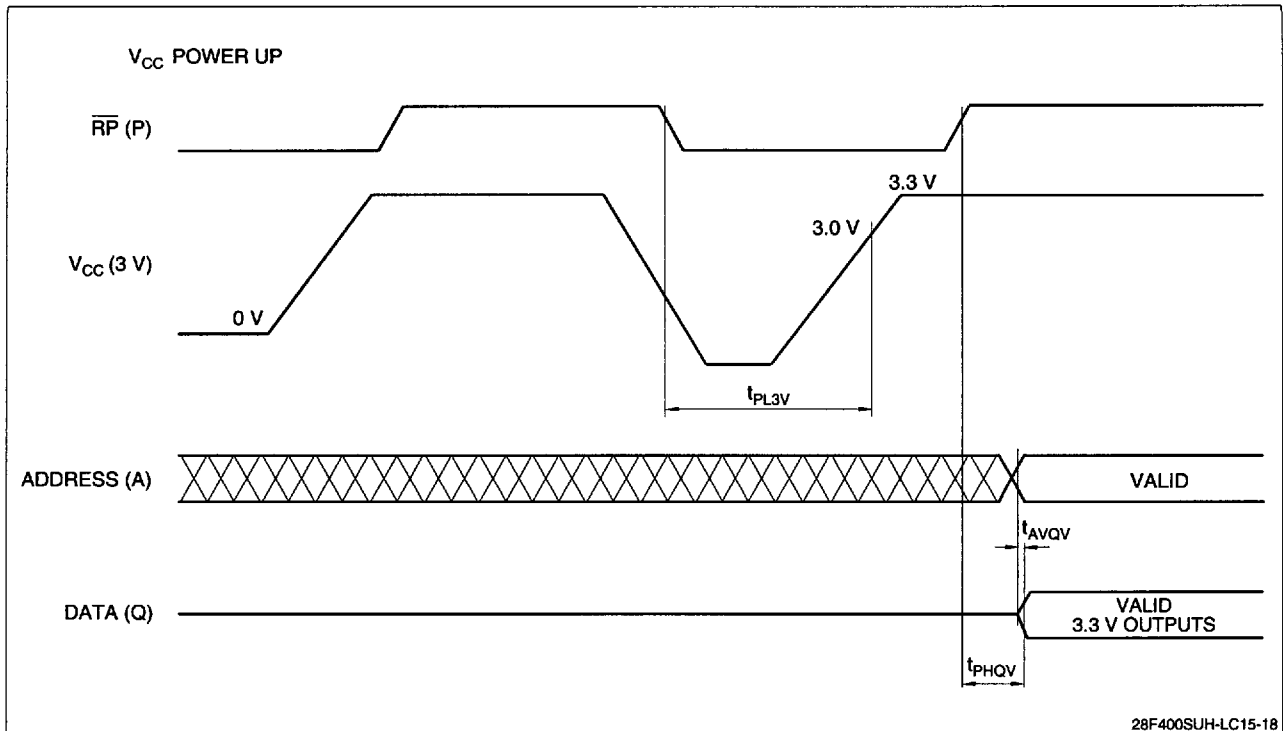

28F400SUH-LC15-18

Figure 18. V_{CC} Power-Up and \overline{RP} Reset Waveforms

SYMBOL	PARAMETER	MIN.	MAX.	UNITS	NOTE
t_{PL3V}	\overline{RP} Low to V_{CC} at 3.0 V MIN.	0		μs	1
t_{AVQV}	Address Valid to Data Valid for $V_{CC} = 3.3 V \pm 0.3 V$		150	ns	2
t_{PHQV}	\overline{RP} High to Data Valid for $V_{CC} = 3.3 V \pm 0.3 V$		750	ns	2

NOTES:

\overline{CE} and \overline{OE} are switched low after Power-Up.

1. The power supply may start to switch concurrently with \overline{RP} going Low.

2. The address access time and \overline{RP} high to data valid time are shown for 3.3 V V_{CC} operation. Refer to the AC Characteristics Read Only Operations also.

AC Characteristics for \overline{WE} - Controlled Command Write Operations¹ $V_{CC} = 3.3V \pm 0.3V, T_A = 0^\circ C \text{ to } +70^\circ C$

SYMBOL	PARAMETER	TYP.	MIN.	MAX.	UNITS	NOTE
t_{AVAV}	Write Cycle Time		150		ns	
t_{VPWH}	V_{PP} Set up to \overline{WE} Going High		100		ns	3
t_{PHEL}	\overline{RP} Setup to \overline{CE} Going Low		480		ns	
t_{ELWL}	\overline{CE} Setup to \overline{WE} Going Low		10		ns	
t_{AVWH}	Address Setup to \overline{WE} Going High		110		ns	2, 6
t_{DVWH}	Data Setup to \overline{WE} Going High		110		ns	2, 6
t_{WLWH}	\overline{WE} Pulse Width		110		ns	
t_{WHDX}	Data Hold from \overline{WE} High		10		ns	2
t_{WHAX}	Address Hold from \overline{WE} High		10		ns	2
t_{WHEH}	\overline{CE} Hold from \overline{WE} High		10		ns	
t_{WHWL}	\overline{WE} Pulse Width High		75		ns	
t_{GHWL}	Read Recovery before Write		0		ns	
t_{WHRL}	\overline{WE} High to $\overline{RY/BY}$ Going Low			100	ns	
t_{RHPL}	\overline{RP} Hold from Valid Status Register Data and $\overline{RY/BY}$ High		0		ns	3
t_{PHWL}	\overline{RP} High Recovery to \overline{WE} Going Low		1		μs	
t_{WHGL}	Write Recovery before Read		120		ns	
t_{QVVL}	V_{PP} Hold from Valid Status Register Data and $\overline{RY/BY}$ High		0		μs	
t_{WHQV}^1	Duration of Byte Write Operation	20	8		μs	4, 5
t_{WHQV}^2	Duration of Block Erase Operation		0.3		s	4

NOTES:

1. Read timing during write and erase are the same as for normal read.
2. Refer to command definition tables for valid address and data values.
3. Sampled, but not 100% tested.
4. Write/Erase durations are measured to valid Status Register (CSR) Data.
5. Byte write operations are typically performed with 1 Programming Pulse.
6. Address and Data are latched on the rising edge of \overline{WE} for all Command Write operations.

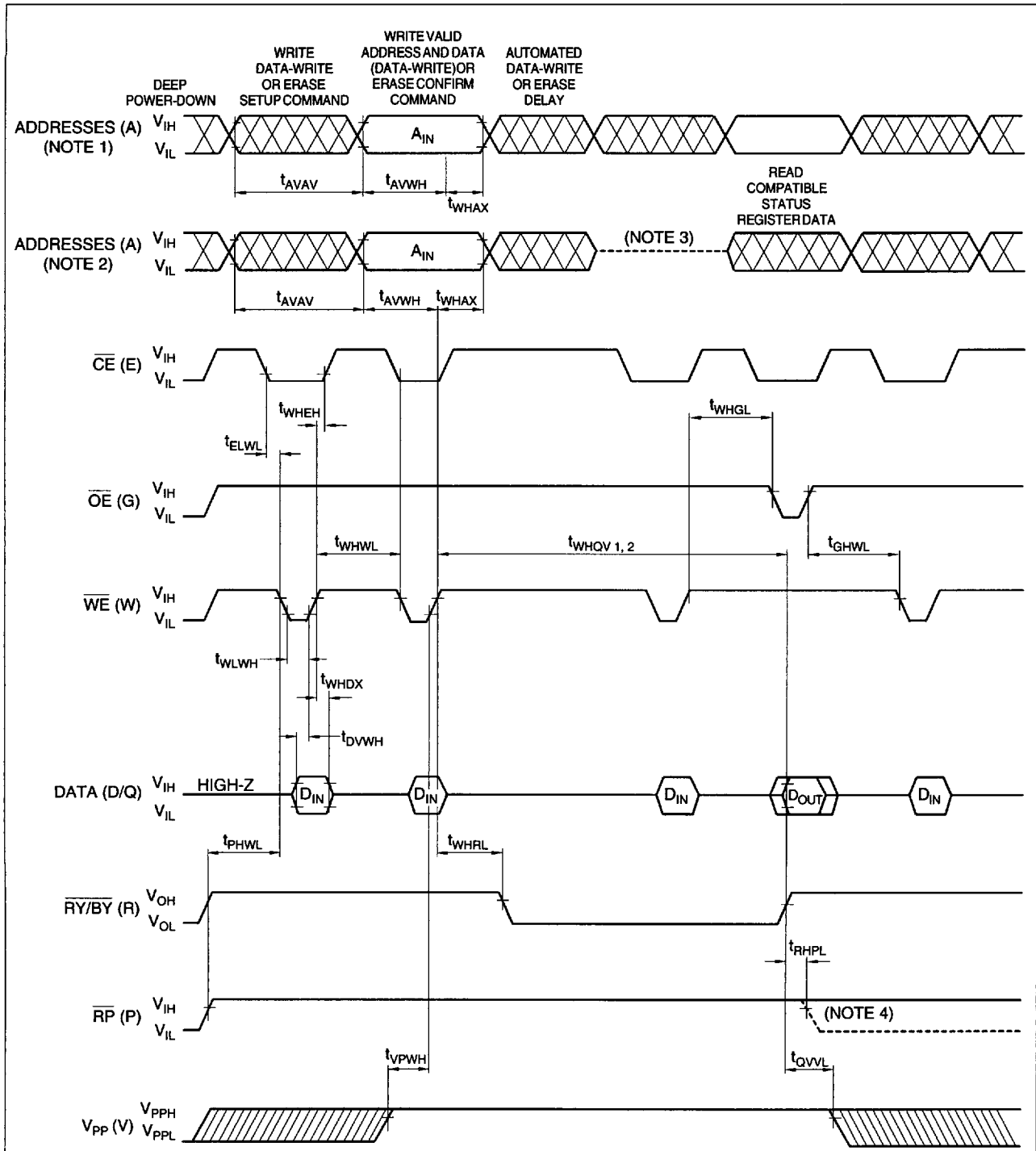

NOTES:

1. This address string depicts Data-Write/Erase cycles with corresponding verification via ESRD.
2. This address string depicts Data-Write/Erase cycles with corresponding verification via CSRD.
3. This cycle is invalid when using CSRD for verification during Data-Write/Erase operations.
4. RP low transition is only to show t_{RHPL} ; not valid for above Read and Write cycles.

28F004SU-Z9-19

Figure 19. AC Waveforms for Command Write Operations

AC Characteristics for \overline{CE} - Controlled Command Write Operations¹

$$V_{CC} = 3.3V \pm 0.3V, T_A = 0^\circ\text{C to } +70^\circ\text{C}$$

SYMBOL	PARAMETER	TYP.	MIN.	MAX.	UNITS	NOTE
t_{AVAV}	Write Cycle Time		150		ns	
t_{PHWL}	\overline{RP} Setup to \overline{WE} Going Low		480		ns	3
t_{VPEH}	V_{PP} Set up to \overline{CE} Going High		100		ns	3
t_{WLEL}	\overline{WE} Setup to \overline{CE} Going Low		0		ns	
t_{AVEH}	Address Setup to \overline{CE} Going High		110		ns	2, 6
t_{DVEH}	Data Setup to \overline{CE} Going High		110		ns	2, 6
t_{ELEH}	\overline{CE} Pulse Width		110		ns	
t_{EHDH}	Data Hold from \overline{CE} High		10		ns	2
t_{EHAX}	Address Hold from \overline{CE} High		10		ns	2
t_{EHWL}	\overline{WE} Hold from \overline{CE} High		10		ns	
t_{EHEL}	\overline{CE} Pulse Width High		75		ns	
t_{GHLE}	Read Recovery before Write		0		ns	
t_{EHRL}	\overline{CE} High to $\overline{RY}/\overline{BY}$ Going Low			100	ns	
t_{RHPL}	\overline{RP} Hold from Valid Status Register Data and $\overline{RY}/\overline{BY}$ High		0		ns	3
t_{PHEL}	\overline{RP} High Recovery to \overline{CE} Going Low		1		μs	
t_{EHGL}	Write Recovery before Read		120		ns	
t_{QVVL}	V_{PP} Hold from Valid Status Register Data and $\overline{RY}/\overline{BY}$ High		0		μs	
t_{EHQV}^1	Duration of Byte Write Operation	20	8		μs	4, 5
t_{EHQV}^2	Duration of Block Erase Operation		0.3		s	4

NOTES:

1. Read timing during write and erase are the same as for normal read.
2. Refer to command definition tables for valid address and data values.
3. Sampled, but not 100% tested.
4. Write/Erase durations are measured to valid Status Register (CSR) Data.
5. Byte Write operations are typically performed with 1 Programming Pulse.
6. Address and Data are latched on the rising edge of \overline{CE} for all Command Write operations.

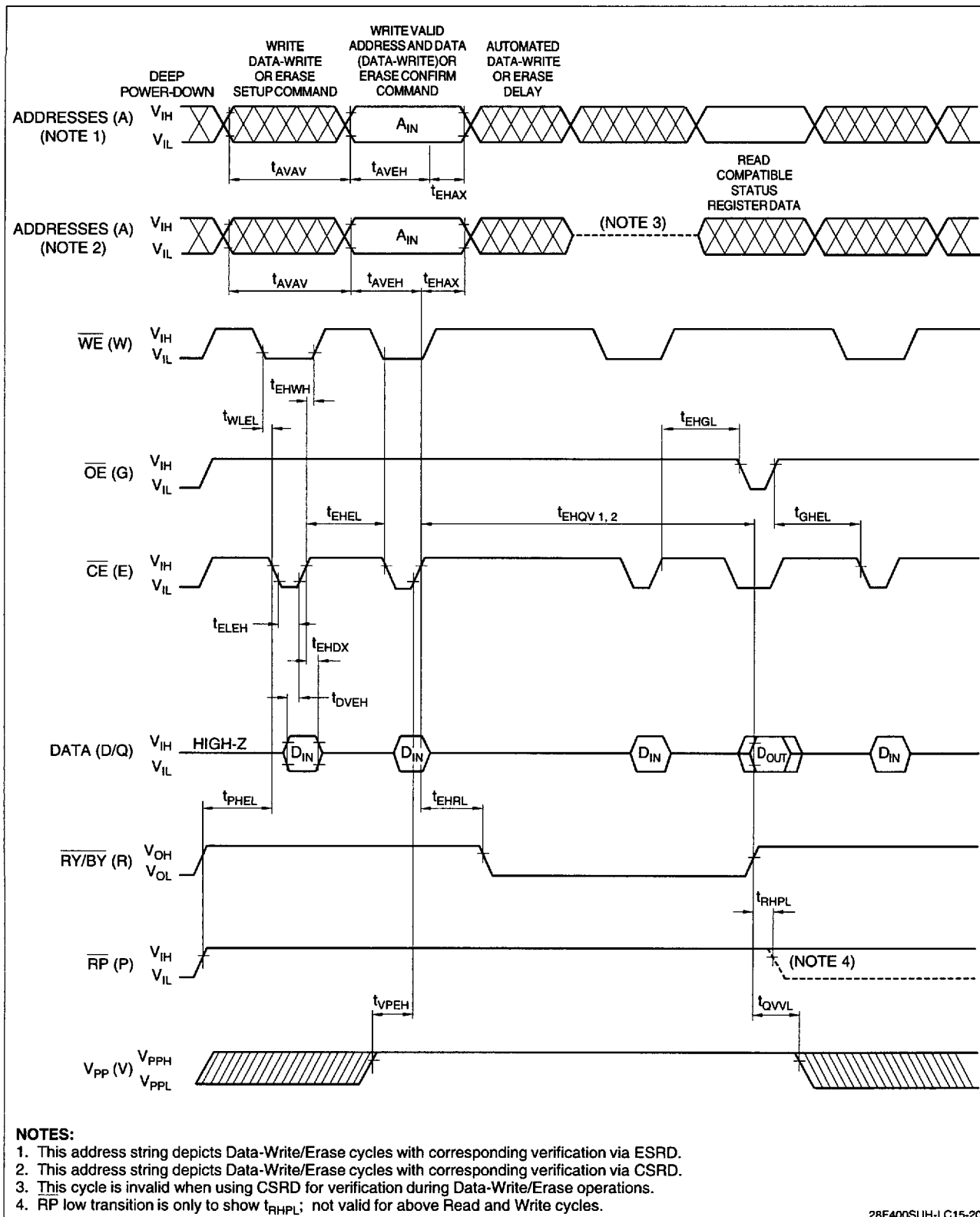

Figure 20. Alternate AC Waveforms for Command Write Operations

Erase and Word/Byte Write Performance

$$V_{CC} = 3.3\text{ V} \pm 0.3\text{ V}, T_A = 0^\circ\text{C to } +70^\circ\text{C}$$

SYMBOL	PARAMETER	TYP ⁽¹⁾	MIN.	MAX.	UNITS	TEST CONDITIONS	NOTE
t_{WHRH}^1	Byte Write Time	20			μs		2
t_{WHRH}^2	Two-Byte Serial Write Time	30			μs		2, 3
t_{WHRH}^3	Word Write Time	30			μs		2, 4
t_{WHRH}^4	16KB Block Write Time	0.33		1.5	s	Byte Write Mode	2
t_{WHRH}^5	16KB Block Write Time	0.26		1.2	s	Two-Byte Serial Write Mode	2, 3
t_{WHRH}^6	16KB Block Write Time	0.26		1.2	s	Word Write Mode	2, 4
	Block Erase Time (16KB)	0.8		13	s		2
	Full Chip Erase Time	12 - 19.2			s		2, 5

NOTES:

1. 25°C, $V_{PP} = 5.0\text{ V}$
2. Excludes System-Level Overhead.
3. Two-Byte SerialWrite mode is valid at x8-bit configuration only.
4. Word Write Mode is valid at x16-bit configuration only.
5. Depends on the number of protected blocks.

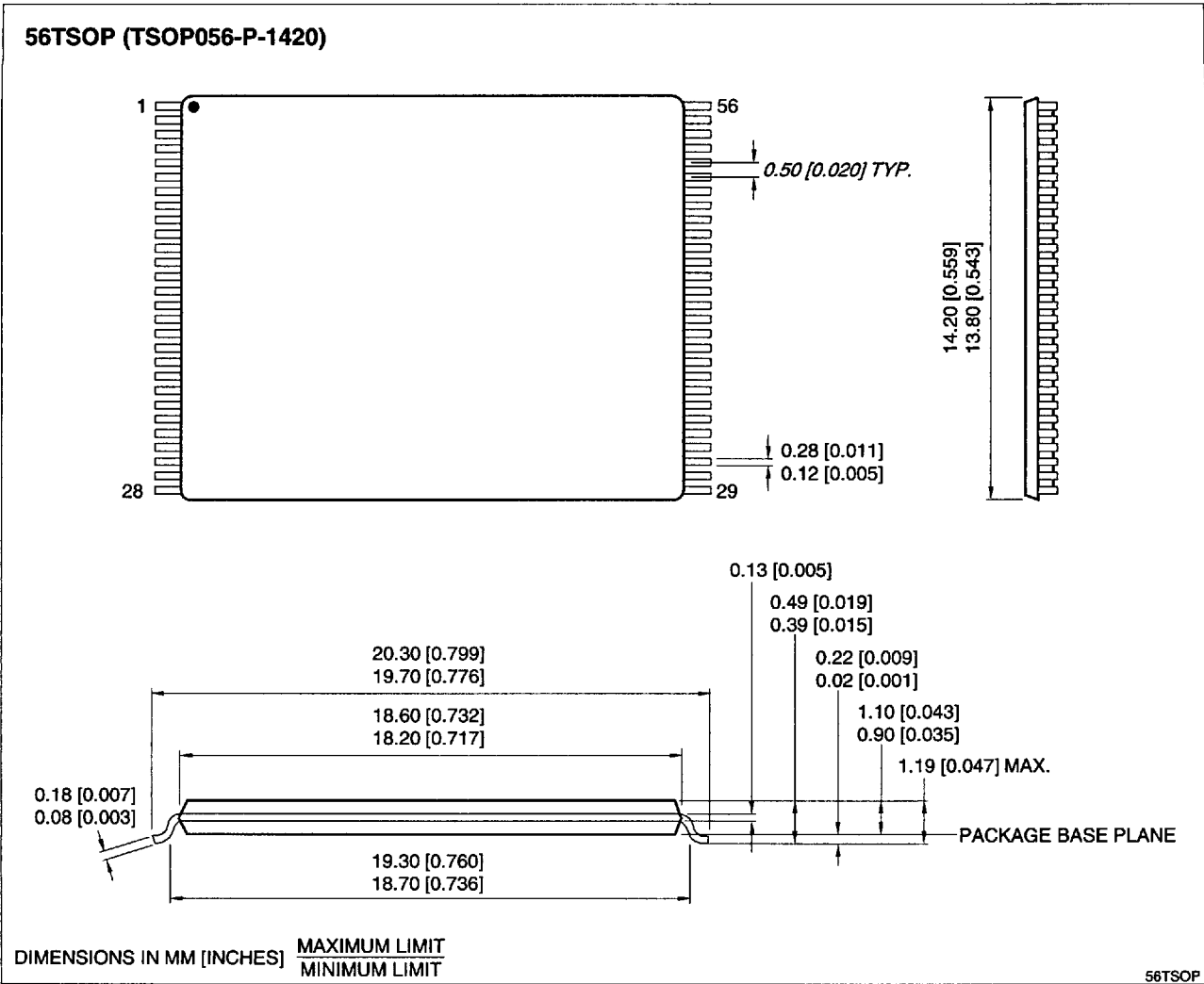

48TSOP (TSOP048-P-1218)

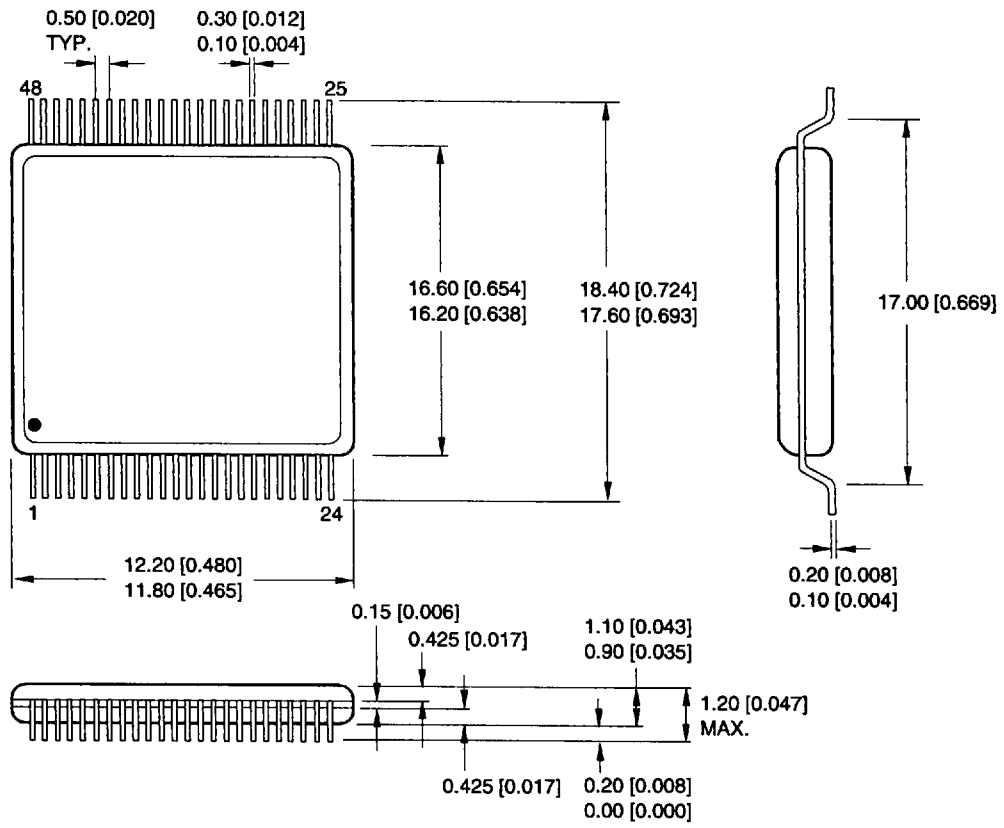

DIMENSIONS IN MM [INCHES] MAXIMUM LIMIT
 MINIMUM LIMIT

48TSOP

44SOP (SOP044-P-0600)

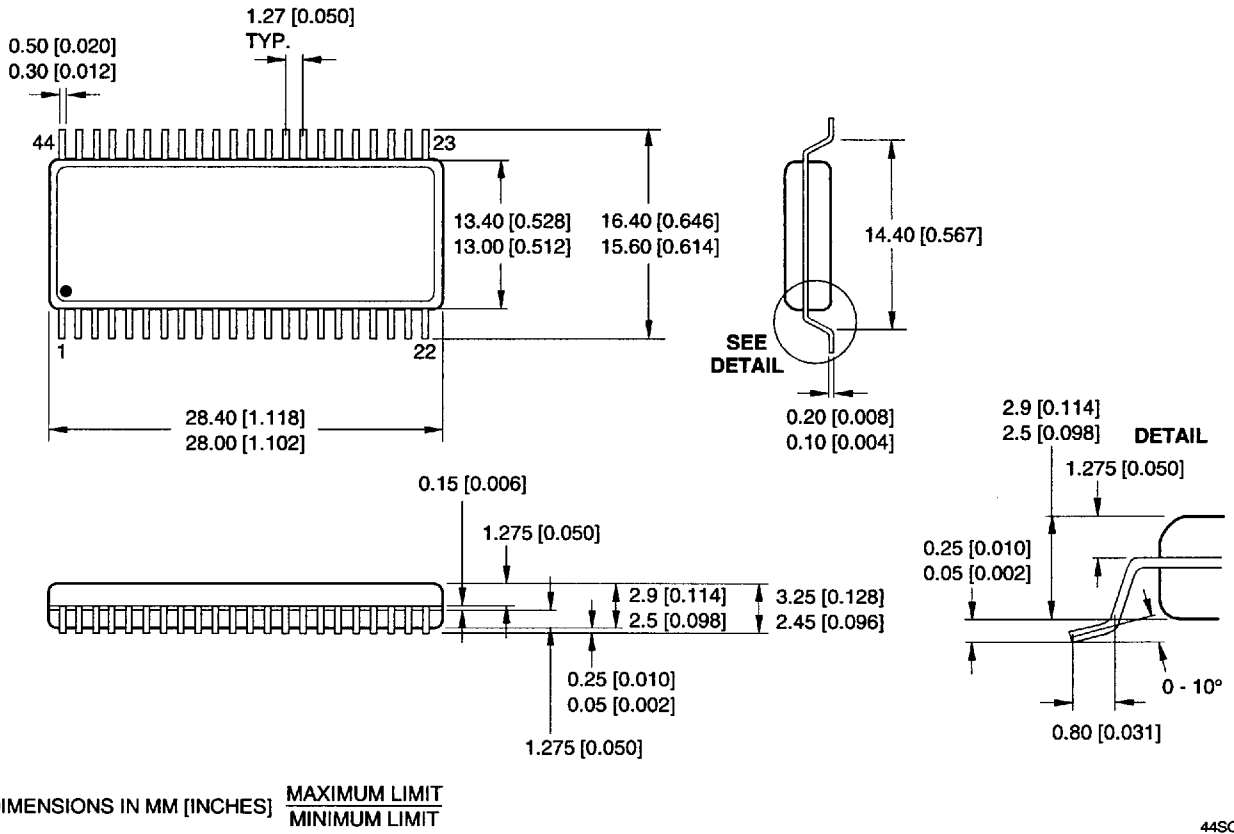

44SOP

ORDERING INFORMATION

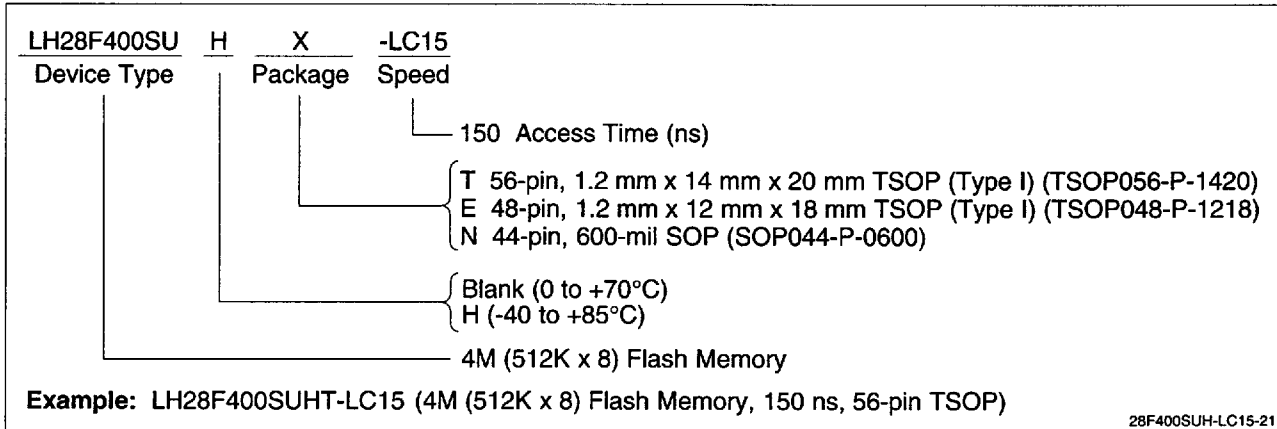

28F400SUH-LC15-21

LIFE SUPPORT POLICY

SHARP components should not be used in medical devices with life support functions or in safety equipment (or similar applications where component failure would result in loss of life or physical harm) without the written approval of an officer of the SHARP Corporation.

WARRANTY

SHARP warrants to Customer that the Products will be free from defects in material and workmanship under normal use and service for a period of one year from the date of invoice. Customer's exclusive remedy for breach of this warranty is that SHARP will either (i) repair or replace, at its option, any Product which fails during the warranty period because of such defect (if Customer promptly reported the failure to SHARP in writing) or, (ii) if SHARP is unable to repair or replace, SHARP will refund the purchase price of the Product upon its return to SHARP. This warranty does not apply to any Product which has been subjected to misuse, abnormal service or handling, or which has been altered or modified in design or construction, or which has been serviced or repaired by anyone other than SHARP. The warranties set forth herein are in lieu of, and exclusive of, all other warranties, express or implied. ALL EXPRESS AND IMPLIED WARRANTIES OF MERCHANTABILITY, FITNESS FOR USE AND FITNESS FOR A PARTICULAR PURPOSE ARE SPECIFICALLY EXCLUDED.

SHARP reserves the right to make changes in specifications at any time and without notice. SHARP does not assume any responsibility for the use of any circuitry described; no circuit patent licenses are implied.

SHARP®

NORTH AMERICA

SHARP Electronics Corporation
Microelectronics Group
5700 NW Pacific Rim Blvd., M/S 20
Camas, WA 98607, U.S.A.
Phone: (360) 834-2500
Telex: 49608472 (SHARPCAM)
Facsimile: (360) 834-8903
<http://www.sharpmeg.com>

EUROPE

SHARP Electronics (Europe) GmbH
Microelectronics Division
Sonninstraße 3
20097 Hamburg, Germany
Phone: (49) 40 2376-2286
Telex: 2161867 (HEEG D)
Facsimile: (49) 40 2376-2232

ASIA

SHARP Corporation
Integrated Circuits Group
2613-1 Ichinomoto-Cho
Tenri-City, Nara, 632, Japan
Phone: (07436) 5-1321
Telex: LABOMETA-B J63428
Facsimile: (07436) 5-1532

©1997 by SHARP Corporation
Issued July 1995

Reference Code SMT96102