



PRELIMINARY

8XC251SA/SB/SP/SQ HIGH-PERFORMANCE CHMOS MICROCONTROLLER

Commercial/Express

- Real-time and Programmed Wait State Bus Operation
- Binary-code Compatible with MCS[®] 51
- Pin Compatible with 44-pin PLCC and 40-pin PDIP MCS 51 Sockets
- Register-based MCS[®] 251 Architecture
 - 40-byte Register File
 - Registers Accessible as Bytes, Words, or Double Words
- Enriched MCS 51 Instruction Set
 - 16-bit and 32-bit Arithmetic and Logic Instructions
 - Compare and Conditional Jump Instructions
 - Expanded Set of Move Instructions
- Linear Addressing
- 256-Kbyte Expanded External Code/Data Memory Space
- ROM/OTPROM/EPROM Options: 16 Kbytes (SB/SQ), 8 Kbytes (SA/SP), or without ROM/OTPROM/EPROM
- 16-bit Internal Code Fetch
- 64-Kbyte Extended Stack Space
- On-chip Data RAM Options: 1-Kbyte (SA/SB) or 512-Byte (SP/SQ)
- 8-bit, 2-clock External Code Fetch in Page Mode
- Fast MCS 251 Instruction Pipeline
- User-selectable Configurations:
 - External Wait States (0-3 wait states)
 - Address Range & Memory Mapping
 - Page Mode
- 32 Programmable I/O Lines
- Seven Maskable Interrupt Sources with Four Programmable Priority Levels
- Three Flexible 16-bit Timer/counters
- Hardware Watchdog Timer
- Programmable Counter Array
 - High-speed Output
 - Compare/Capture Operation
 - Pulse Width Modulator
 - Watchdog Timer
- Programmable Serial I/O Port
 - Framing Error Detection
 - Automatic Address Recognition
- High-performance CHMOS Technology
- Static Standby to 16-MHz Operation
- Complete System Development Support
 - Compatible with Existing Tools
 - New MCS 251 Tools Available: Compiler, Assembler, Debugger, ICE
- Package Options (PDIP, PLCC, and Ceramic DIP)

A member of the Intel family of 8-bit MCS 251 microcontrollers, the 8XC251SA/SB/SP/SQ is binary-code compatible with MCS 51 microcontrollers and pin compatible with 40-pin PDIP and 44-pin PLCC MCS 51 microcontrollers. MCS 251 microcontrollers feature an enriched instruction set, linear addressing, and efficient C-language support. The 8XC251SA/SB/SP/SQ has 512 bytes or 1 Kbyte of on-chip RAM and is available with 8 Kbytes or 16 Kbytes of on-chip ROM/OTPROM/EPROM, or without ROM/OTPROM/EPROM. A variety of features can be selected by new user-programmable configurations.

Information in this document is provided in connection with Intel products. No license, express or implied, by estoppel or otherwise, to any intellectual property rights is granted by this document. Except as provided in Intel's Terms and Conditions of Sale for such products, Intel assumes no liability whatsoever, and Intel disclaims any express or implied warranty, relating to sale and/or use of Intel products including liability or warranties relating to fitness for a particular purpose, merchantability, or infringement of any patent, copyright or other intellectual property right. Intel products are not intended for use in medical, life saving, or life sustaining applications.

Intel retains the right to make changes to specifications and product descriptions at any time, without notice.

*Third-party brands and names are the property of their respective owners.

Copies of documents which have an ordering number and are referenced in this document, or other Intel literature, may be obtained from:

Intel Corporation
P.O. Box 7641
Mt. Prospect IL 60056-764
or call 1-800-548-4725

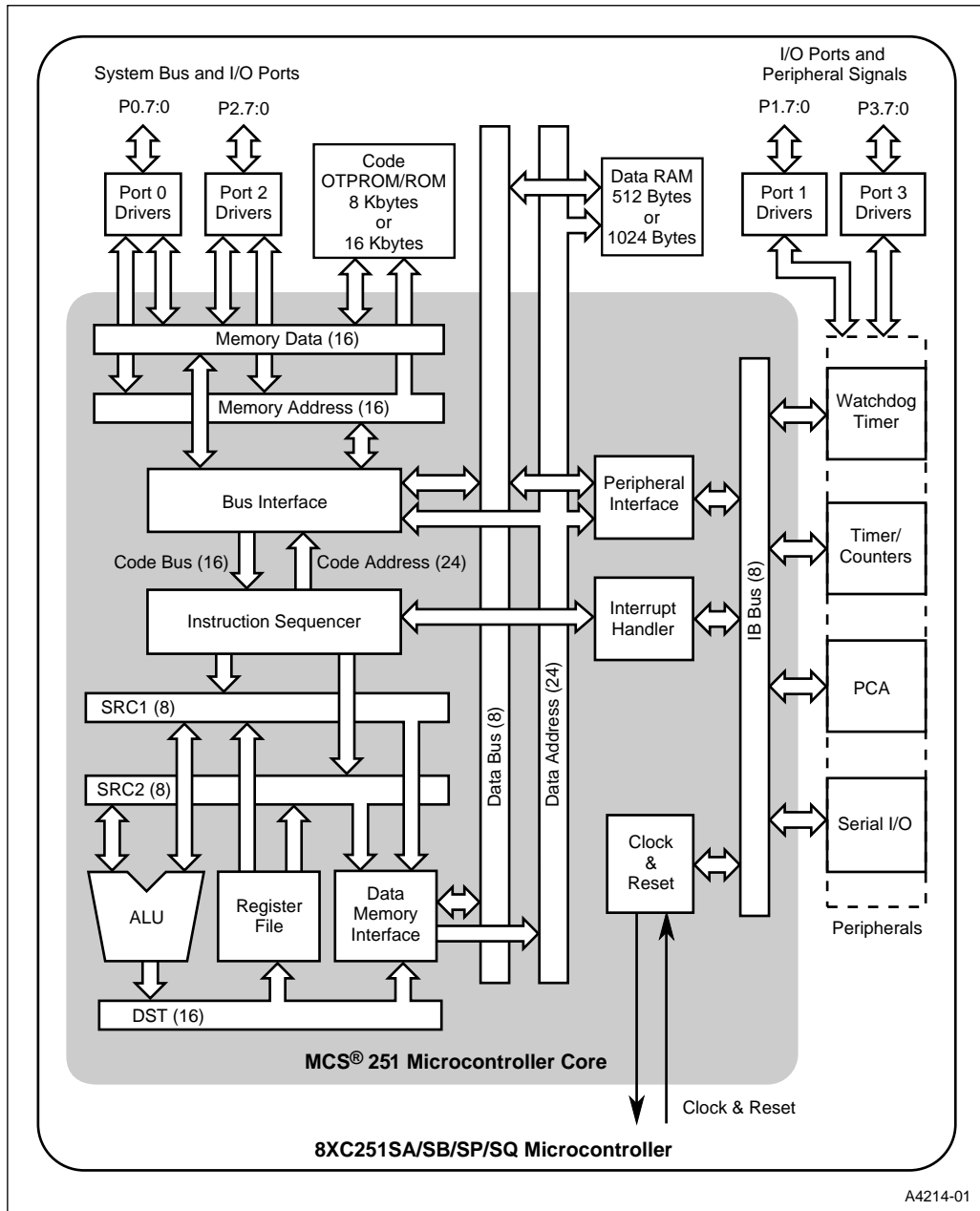

Figure 1. 8XC251SA/SB/SP/SQ Block Diagram



1.0 NOMENCLATURE

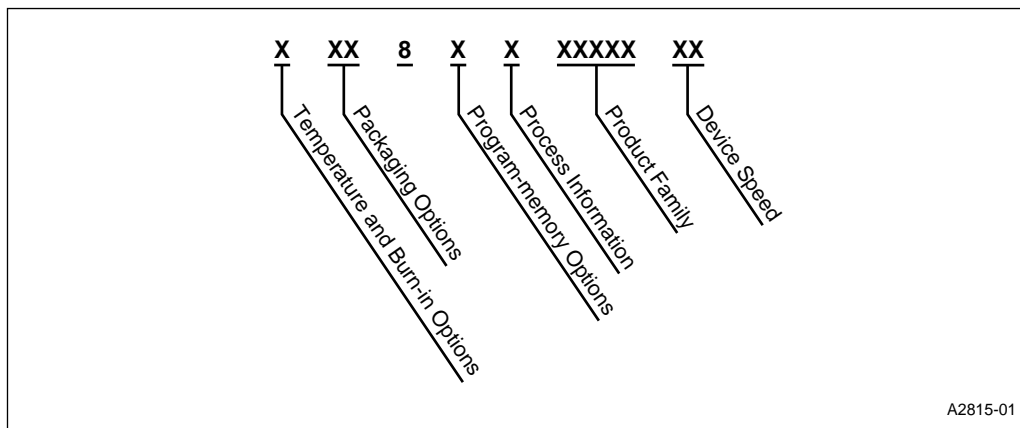

Figure 2. The 8XC251SA/SB/SP/SQ Family Nomenclature

Table 1. Description of Product Nomenclature

Parameter	Options	Description
Temperature and Burn-in Options	no mark	Commercial operating temperature range (0°C to 70°C) with Intel standard burn-in.
	T	Express operating temperature range (-40°C to 85°C) with Intel standard burn-in.
Packaging Options	N	44-pin Plastic Leaded Chip Carrier (PLCC)
	P	40-pin Plastic Dual In-line Package (PDIP)
	C	40-pin Ceramic Dual In-line Package (Ceramic DIP)
Program Memory Options	0	Without ROM/OTPROM/EPROM
	3	ROM
	7	User programmable OTPROM/EPROM
Process Information	C	CHMOS
Product Family	251	8-bit control architecture
Device Memory Options	SA	1-Kbyte RAM/8-Kbyte ROM/OTPROM/EPROM
	SB	1-Kbyte RAM/16-Kbyte ROM/OTPROM/EPROM or without ROM/OTPROM/EPROM
	SP	512-byte RAM/8-Kbyte ROM/OTPROM/EPROM
	SQ	512-byte RAM/16-Kbyte ROM/OTPROM/EPROM or without ROM/OTPROM/EPROM
Device Speed	16	External clock frequency

Table 2 lists the proliferation options. See Figure 2 for the 8XC251SA/SB/SP/SQ family nomenclature.

Table 2. Proliferation Options

8XC251SA/SB/SP/SQ (0 – 16 MHz; 5 V ±10%)	
80C251SB16	CPU-only
80C251SQ16	CPU-only
83C251SA16	ROM
83C251SB16	ROM
83C251SP16	ROM
83C251SQ16	ROM
87C251SA16	OTPROM/EPROM
87C251SB16	OTPROM/EPROM
87C251SP16	OTPROM/EPROM
87C251SQ16	OTPROM/EPROM

Table 3 lists the 8XC251SA/SB/SP/SQ packages.

Table 3. Package Information

Pkg.	Definition	Temperature
N	44 ld. PLCC	0°C to +70°C
P	40 ld. Plastic DIP	0°C to +70°C
C	40 ld. Ceramic DIP	0°C to +70°C
TN	44 ld. PLCC	-40°C to +85°C
TP	40 ld. Plastic DIP	-40°C to +85°C

2.0 PINOUT

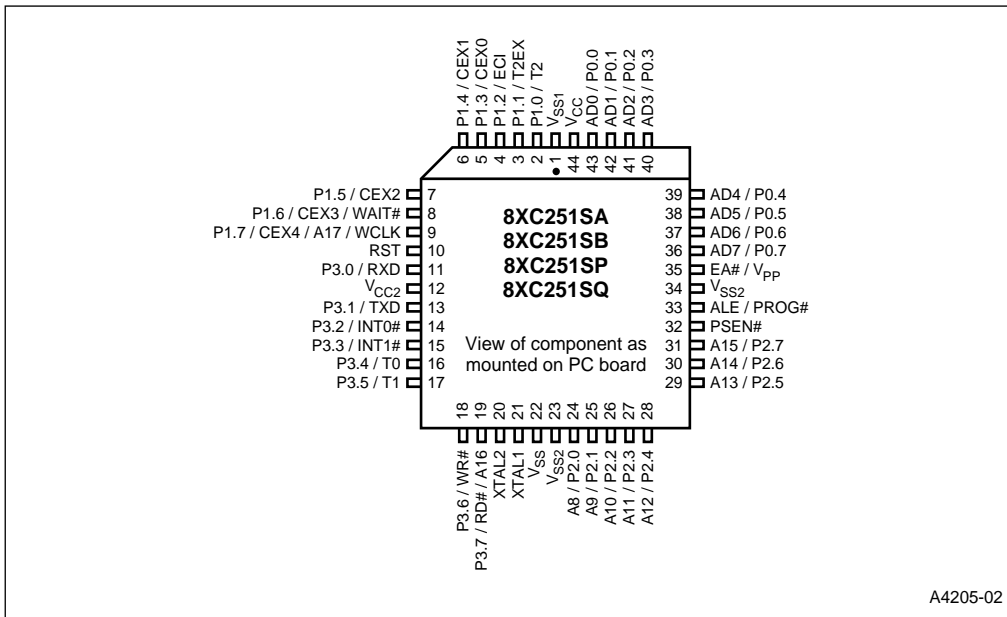

Figure 3. 8XC251SA/SB/SP/SQ 44-pin PLCC Package



8XC251SA/SB/SP/SQ HIGH-PERFORMANCE CHMOS MICROCONTROLLER

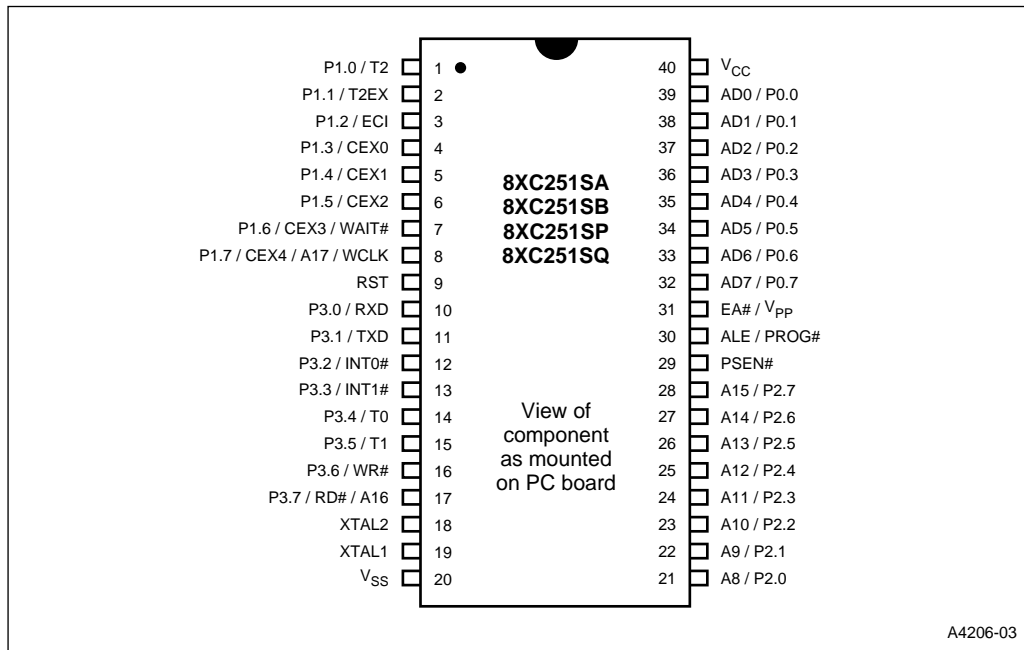

Figure 4. 8XC251SA/SB/SP/SQ 40-pin PDIP and Ceramic DIP Packages

Table 4. 8XC251SA/SB/SP/SQ Pin Assignment

PLCC	DIP	Name	PLCC	DIP	Name
1		V_{SS1}	23		V_{SS2}
2	1	P1.0/T2	24	21	A8/P2.0
3	2	P1.1/T2EX	25	22	A9/P2.1
4	3	P1.2/ECI	26	23	A10/P2.2
5	4	P1.3/CEX0	27	24	A11/P2.3
6	5	P1.4/CEX1	28	25	A12/P2.4
7	6	P1.5/CEX2	29	26	A13/P2.5
8	7	P1.6/CEX3/WAIT#	30	27	A14/P2.6
9	8	P1.7/CEX4/A17/WCLK	31	28	A15/P2.7
10	9	RST	32	29	PSEN#
11	10	P3.0/RXD	33	30	ALE/PROG#
12		V_{CC2}	34		V_{SS2}
13	11	P3.1/TXD	35	31	EA#/ V_{PP}
14	12	P3.2/INT0#	36	32	AD7/P0.7
15	13	P3.3/INT1#	37	33	AD6/P0.6
16	14	P3.4/T0	38	34	AD5/P0.5
17	15	P3.5/T1	39	35	AD4/P0.4
18	16	P3.6/WR#	40	36	AD3/P0.3
19	17	P3.7/RD#/A16	41	37	AD2/P0.2
20	18	XTAL2	42	38	AD1/P0.1
21	19	XTAL1	43	39	AD0/P0.0
22	20	V_{SS}	44	40	V_{CC}



Table 5. 8XC251SA/SB/SP/SQ PLCC/DIP Pin Assignments Arranged by Functional Category

Address & Data		
Name	PLCC	DIP
AD0/P0.0	43	39
AD1/P0.1	42	38
AD2/P0.2	41	37
AD3/P0.3	40	36
AD4/P0.4	39	35
AD5/P0.5	38	34
AD6/P0.6	37	33
AD7/P0.7	36	32
A8/P2.0	24	21
A9/P2.1	25	22
A10/P2.2	26	23
A11/P2.3	27	24
A12/P2.4	28	25
A13/P2.5	29	26
A14/P2.6	30	27
A15/P2.7	31	28
P3.7/RD#/A16	19	17
P1.7/CEX4/A17/WCLK	9	8

Processor Control		
Name	PLCC	DIP
P3.2/INT0#	14	12
P3.3/INT1#	15	13
EA#/ V_{PP}	35	31
RST	10	9
XTAL1	21	18
XTAL2	20	19

Input/Output		
Name	PLCC	DIP
P1.0/T2	2	1
P1.1/T2EX	3	2
P1.2/ECI	4	3
P1.3/CEX0	5	4
P1.4/CEX1	6	5
P1.5/CEX2	7	6
P1.6/CEX3/WAIT#	8	7
P1.7/CEX4/A17/WCLK	9	8
P3.0/RXD	11	10
P3.1/TXD	13	11
P3.4/T0	16	14
P3.5/T1	17	15

Power & Ground		
Name	PLCC	DIP
V_{CC}	44	40
V_{CC2}	12	
V_{SS}	22	20
V_{SS1}	1	
V_{SS2}	23, 34	
EA#/ V_{PP}	35	31

Bus Control & Status		
Name	PLCC	DIP
P3.6/WR#	18	16
P3.7/RD#/A16	19	17
ALE/PROG#	33	30
PSEN#	32	29

3.0 SIGNALS

Table 6. Signal Descriptions

Signal Name	Type	Description	Alternate Function
A17	O	18th Address Bit (A17). Output to memory as 18th external address bit (A17) in extended bus applications, depending on the values of bits RD0 and RD1 in configuration byte UCONFIG0 (see Chapter 4, "Device Configuration," of the 8XC251SA/SB/SP/SQ Embedded Microcontroller User's Manual). See also RD# and PSEN#.	P1.7/CEX4/ WCLK
A16	O	Address Line 16. See RD#.	RD#
A15:8 [†]	O	Address Lines. Upper address lines for the external bus.	P2.7:0
AD7:0 [†]	I/O	Address/Data Lines. Multiplexed lower address lines and data lines for external memory.	P0.7:0
ALE	O	Address Latch Enable. ALE signals the start of an external bus cycle and indicates that valid address information is available on lines A15:8 and AD7:0. An external latch can use ALE to demultiplex the address from the address/data bus.	PROG#
CEX4:0	I/O	Programmable Counter Array (PCA) Input/Output Pins. These are input signals for the PCA capture mode and output signals for the PCA compare mode and PCA PWM mode.	P1.6:3 P1.7/A17/ WAIT#
EA#	I	External Access. Directs program memory accesses to on-chip or off-chip code memory. For EA# = 0, all program memory accesses are off-chip. For EA# = 1, an access is to on-chip ROM/OTPROM/EPROM if the address is within the range of the on-chip ROM/OTPROM/EPROM; otherwise the access is off-chip. The value of EA# is latched at reset. For devices without on-chip ROM/OTPROM/EPROM, EA# must be strapped to ground.	V _{PP}
ECI	I	PCA External Clock Input. External clock input to the 16-bit PCA timer.	P1.2
INT1:0#	I	External Interrupts 0 and 1. These inputs set bits IE1:0 in the TCON register. If bits IT1:0 in the TCON register are set, bits IE1:0 are set by a falling edge on INT1#/INT0#. If bits INT1:0 are clear, bits IE1:0 are set by a low level on INT1:0#.	P3.3:2
PROG#	I	Programming Pulse. The programming pulse is applied to this pin for programming the on-chip OTPROM.	ALE
P0.7:0	I/O	Port 0. This is an 8-bit, open-drain, bidirectional I/O port.	AD7:0
P1.0 P1.1 P1.2 P1.7:3	I/O	Port 1. This is an 8-bit, bidirectional I/O port with internal pullups.	T2 T2EX ECI CEX3:0 CEX4/A17/ WAIT#/ WCLK
P2.7:0	I/O	Port 2. This is an 8-bit, bidirectional I/O port with internal pullups.	A15:8

[†] The descriptions of A15:8/P2.7:0 and AD7:0/P0.7:0 are for the nonpage-mode chip configuration (compatible with 44-pin PLCC and 40-pin DIP MCS 51 microcontrollers). If the chip is configured for page-mode operation, port 0 carries the lower address bits (A7:0), and port 2 carries the upper address bits (A15:8) and the data (D7:0).



Table 6. Signal Descriptions (Continued)

Signal Name	Type	Description	Alternate Function
P3.0 P3.1 P3.3:2 P3.5:4 P3.6 P3.7	I/O	Port 3. This is an 8-bit, bidirectional I/O port with internal pullups.	RXD TXD INT1:0# T1:0 WR# RD#/A16
PSEN#	O	Program Store Enable. Read signal output. This output is asserted for a memory address range that depends on bits RD0 and RD1 in configuration byte UCONFIG0 (see RD# and Chapter 4, "Device Configuration," in the 8XC251SA/SB/SP/SQ Embedded Microcontroller User's Manual).	—
RD#	O	Read or 17th Address Bit (A16). Read signal output to external data memory or 17th external address bit (A16), depending on the values of bits RD0 and RD1 in configuration byte UCONFIG0. (See PSEN# and Chapter 4, "Device Configuration," in the 8XC251SA/SB/SP/SQ Embedded Microcontroller User's Manual).	P3.7/A16
RST	I	Reset. Reset input to the chip. Holding this pin high for 64 oscillator periods while the oscillator is running resets the device. The port pins are driven to their reset conditions when a voltage greater than V_{IH1} is applied, whether or not the oscillator is running. This pin has an internal pulldown resistor, which allows the device to be reset by connecting a capacitor between this pin and V_{CC} . Asserting RST when the chip is in idle mode or powerdown mode returns the chip to normal operation.	—
RXD	I/O	Receive Serial Data. RXD sends and receives data in serial I/O mode 0 and receives data in serial I/O modes 1, 2, and 3.	P3.0
T1:0	I	Timer 1:0 External Clock Inputs. When timer 1:0 operates as a counter, a falling edge on the T1:0 pin increments the count.	P3.5:4
T2	I/O	Timer 2 Clock Input/Output. For the timer 2 capture mode, this signal is the external clock input. For the clock-out mode, it is the timer 2 clock output.	P1.0
T2EX	I	Timer 2 External Input. In timer 2 capture mode, a falling edge initiates a capture of the timer 2 registers. In auto-reload mode, a falling edge causes the timer 2 registers to be reloaded. In the up-down counter mode, this signal determines the count direction: 1 = up, 0 = down.	P1.1
TXD	O	Transmit Serial Data. TXD outputs the shift clock in serial I/O mode 0 and transmits serial data in serial I/O modes 1, 2, and 3.	P3.1
V_{CC}	PWR	Supply Voltage. Connect this pin to the +5V supply voltage.	—
V_{CC2}	PWR	Secondary Supply Voltage 2. This supply voltage connection is provided to reduce power supply noise. Connection of this pin to the +5V supply voltage is recommended. However, when using the 8XC251SB as a pin-for-pin replacement for the 8XC51FX, V_{SS2} can be unconnected without loss of compatibility. (Not available on DIP)	—

† The descriptions of A15:8/P2.7:0 and AD7:0/P0.7:0 are for the nonpage-mode chip configuration (compatible with 44-pin PLCC and 40-pin DIP MCS 51 microcontrollers). If the chip is configured for page-mode operation, port 0 carries the lower address bits (A7:0), and port 2 carries the upper address bits (A15:8) and the data (D7:0).

Table 6. Signal Descriptions (Continued)

Signal Name	Type	Description	Alternate Function
V _{PP}	I	Programming Supply Voltage. The programming supply voltage is applied to this pin for programming the on-chip OTPROM/EPROM.	EA#
V _{SS}	GND	Circuit Ground. Connect this pin to ground.	—
V _{SS1}	GND	Secondary Ground. This ground is provided to reduce ground bounce and improve power supply bypassing. Connection of this pin to ground is recommended. However, when using the 8XC251SA/SB/SP/SQ as a pin-for-pin replacement for the 8XC51BH, V _{SS1} can be unconnected without loss of compatibility. (Not available on DIP)	—
V _{SS2}	GND	Secondary Ground 2. This ground is provided to reduce ground bounce and improve power supply bypassing. Connection of this pin to ground is recommended. However, when using the 8XC251SB as a pin-for-pin replacement for the 8XC51FX, V _{SS2} can be unconnected without loss of compatibility. (Not available on DIP)	—
WAIT#	I	Real-time Wait State Input. The real-time WAIT# input is enabled by writing a logical '1' to the WCON.0 (RTWE) bit at S:A7H. During bus cycles, the external memory system can signal 'system ready' to the microcontroller in real time by controlling the WAIT# input signal on the port 1.6 input.	P1.6/CEX3
WCLK	O	Wait Clock Output. The real-time WCLK output is driven at port 1.7 (WCLK) by writing a logical '1' to the WCON.1 (RTWCE) bit at S:A7H. When enabled, the WCLK output produces a square wave signal with a period of one-half the oscillator frequency.	P1.7/CEX4/A17
WR#	O	Write. Write signal output to external memory.	P3.6
XTAL1	I	Input to the On-chip, Inverting, Oscillator Amplifier. To use the internal oscillator, a crystal/resonator circuit is connected to this pin. If an external oscillator is used, its output is connected to this pin. XTAL1 is the clock source for internal timing.	—
XTAL2	O	Output of the On-chip, Inverting, Oscillator Amplifier. To use the internal oscillator, a crystal/resonator circuit is connected to this pin. If an external oscillator is used, leave XTAL2 unconnected.	—

[†] The descriptions of A15:8/P2.7:0 and AD7:0/P0.7:0 are for the nonpage-mode chip configuration (compatible with 44-pin PLCC and 40-pin DIP MCS 51 microcontrollers). If the chip is configured for page-mode operation, port 0 carries the lower address bits (A7:0), and port 2 carries the upper address bits (A15:8) and the data (D7:0).

Table 7. Memory Signal Selections (RD1:0)

RD1:0	P1.7/CEX/ A17/WCLK	P3.7/RD#/A16	PSEN#	WR#	Features
0 0	A17	A16	Asserted for all addresses	Asserted for writes to all memory locations	256-Kbyte external memory
0 1	P1.7/CEX4/ WCLK	A16	Asserted for all addresses	Asserted for writes to all memory locations	128-Kbyte external memory
1 0	P1.7/CEX4/ WCLK	P3.7 only	Asserted for all addresses	Asserted for writes to all memory locations	64-Kbyte external memory. One additional port pin.
1 1	P1.7/CEX4/ WCLK	RD# asserted for addresses ≤ 7F:FFFFH	Asserted for ≥ 80:0000H	Asserted only for writes to MCS 51 microcontroller data memory locations.	64-Kbyte external memory. Compatible with MCS 51 microcontrollers.

4.0 ADDRESS MAP

Table 8. 8XC251SA/SB/SP/SQ Address Map

Internal Address)	Description	Notes
FF:FFFFH FF:4000H	External Memory except the top eight bytes (FF:FFF8H–FF:FFFFH) which are reserved for the configuration array.	1, 3, 10
FF:3FFFH FF:0000H	External memory or on-chip nonvolatile memory (8Kbytes FF:0000H - FF:1FFFH, 16Kbytes FF:0000H - FF:3FFFH).	3, 4, 5
FE:FFFFH FE:0000H	External Memory	3
FD:FFFFH 02:0000H	Reserved	6
01:FFFFH 01:0000H	External Memory	3
00:FFFFH 00:E000H	External memory or with configuration bit EMAP# = 0, addresses in this range access on-chip code memory in region FF: (16 Kbyte devices only).	5, 7
00:DFFFH 00:0420H	External Memory	7
00:041FH 00:0080H	On-chip RAM (512 bytes 00:0020H - 00:021FH, 1024 bytes 00:0020H - 00:041FH)	7
00:007FH 00:0020H	On-chip RAM	8
00:001FH 00:0000H	Storage for R0–R7 of Register File	2, 9

NOTES:

- 18 address lines are bonded out (A15:0, A16:0, or A17:0 selected during chip configuration).
- The special function registers (SFRs) and the register file have separate internal address spaces.
- Data in this area is accessible by indirect addressing only.
- Devices reset into internal or external starting locations depending on the state of EA# and configuration byte information See EA#. See also UCONFIG1:0 bit definitions in the 8XC251SA/SB/SP/SQ Embedded Microcontroller User's Manual.
- The 16-Kbyte ROM/OTPROM/EPROM devices allow internal locations FF:2000H–FF:3FFFH to map into region 00:. In this case, if EA# = 1, a data read to 00:E000H–00:FFFFH is redirected to internal ROM/OTPROM/EPROM (see bit 1 in UCONFIG0). This is not available for 8-Kbyte ROM/OTPROM/EPROM devices.
- This reserved area returns indeterminate values.
- Data is accessible by direct and indirect addressing.
- Data is accessible by direct, indirect, and bit addressing.
- Data is accessible by direct, indirect, and register addressing.
- Eight addresses at the top of all external memory maps are reserved for current and future device configuration byte information.



5.0 ELECTRICAL CHARACTERISTICS

ABSOLUTE MAXIMUM RATINGS

Storage Temperature	-65°C to +150°C
Voltage on EA#/V _{PP} Pin to V _{SS}	0 V to +13.0 V
Voltage on Any other Pin to V _{SS}	-0.5 V to +6.5 V
I _{OL} per I/O Pin	15 mA
Power Dissipation	1.5 W

NOTICE: This document contains preliminary information on new products in production. The specifications are subject to change without notice. Verify with your local Intel sales office that you have the latest datasheet before finalizing a design.

OPERATING CONDITIONS[†]

T _A (Ambient Temperature Under Bias):	
Commercial	0°C to +70°C
Express	-40°C to +85°C
V _{CC} (Digital Supply Voltage)	4.5 V to 5.5 V
V _{SS}	0 V

[†] **WARNING:** *Stressing the device beyond the "Absolute Maximum Ratings" may cause permanent damage. These are stress ratings only. Operation beyond the "Operating Conditions" is not recommended and extended exposure beyond the "Operating Conditions" may affect device reliability.*

NOTE

Maximum power dissipation is based on package heat-transfer limitations, not device power consumption.

5.1 D.C. Characteristics

Parameter values apply to all devices unless otherwise indicated.

Table 9. DC Characteristics at $V_{CC} = 4.5 - 5.5$ V

Symbol	Parameter	Min	Typical	Max	Units	Test Conditions
V_{IL}	Input Low Voltage (except EA#)	-0.5		$0.2V_{CC} - 0.1$	V	
V_{IL1}	Input Low Voltage (EA#)	0		$0.2V_{CC} - 0.3$	V	
V_{IH}	Input High Voltage (except XTAL1, RST)	$0.2V_{CC} + 0.9$		$V_{CC} + 0.5$	V	
V_{IH1}	Input High Voltage (XTAL1, RST)	$0.7V_{CC}$		$V_{CC} + 0.5$	V	
V_{OL}	Output Low Voltage (Port 1, 2, 3)			0.3 0.45 1.0	V	$I_{OL} = 100 \mu A$ $I_{OL} = 1.6 \text{ mA}$ $I_{OL} = 3.5 \text{ mA}$ (Note 1, Note 2)
V_{OL1}	Output Low Voltage (Port 0, ALE, PSEN#)			0.3 0.45 1.0	V	$I_{OL} = 200 \mu A$ $I_{OL} = 3.2 \text{ mA}$ $I_{OL} = 7.0 \text{ mA}$ (Note 1, Note 2)
V_{OH}	Output High Voltage (Port 1, 2, 3, ALE, PSEN#)	$V_{CC} - 0.3$ $V_{CC} - 0.7$ $V_{CC} - 1.5$			V	$I_{OH} = -10 \mu A$ $I_{OH} = -30 \mu A$ $I_{OH} = -60 \mu A$ (Note 3)

NOTES:

- Under steady-state (non-transient) conditions, I_{OL} must be externally limited as follows:

Maximum I_{OL} per port pin: 10 mA

Maximum I_{OL} per 8-bit port:

port 0 26 mA
ports 1–3 15 mA

Maximum Total I_{OL} for all output pins 71 mA

If I_{OL} exceeds the test conditions, V_{OL} may exceed the related specification. Pins are not guaranteed to sink current greater than the listed test conditions.

- Capacitive loading on ports 0 and 2 may cause spurious noise pulses above 0.4 V on the low-level outputs of ALE and ports 1, 2, and 3. The noise is due to external bus capacitance discharging into the port 0 and port 2 pins when these pins change from high to low. In applications where capacitive loading exceeds 100 pF, the noise pulses on these signals may exceed 0.8 V. It may be desirable to qualify ALE or other signals with a Schmitt trigger or CMOS-level input logic.
- Capacitive loading on ports 0 and 2 causes the V_{OH} on ALE and PSEN# to drop below the specification when the address lines are stabilizing.
- Typical values are obtained using $V_{CC} = 5.0$, $T_A = 25^\circ\text{C}$ and are not guaranteed.



Table 9. DC Characteristics at $V_{CC} = 4.5 - 5.5 \text{ V}$ (Continued)

Symbol	Parameter	Min	Typical	Max	Units	Test Conditions
V_{OH1}	Output High Voltage (Port 0 in External Address)	$V_{CC} - 0.3$ $V_{CC} - 0.7$ $V_{CC} - 1.5$			V	$I_{OH} = -200 \mu\text{A}$ $I_{OH} = -3.2 \text{ mA}$ $I_{OH} = -7.0 \text{ mA}$
V_{OH2}	Output High Voltage (Port 2 in External Address during Page Mode)	$V_{CC} - 0.3$ $V_{CC} - 0.7$ $V_{CC} - 1.5$			V	$I_{OH} = -200 \mu\text{A}$ $I_{OH} = -3.2 \text{ mA}$ $I_{OH} = -7.0 \text{ mA}$
I_{IL}	Logical 0 Input Current (Port 1, 2, 3)			-50	μA	$V_{IN} = 0.45 \text{ V}$
I_{LI}	Input Leakage Current (Port 0)			+/-10	μA	$0.45 < V_{IN} < V_{CC}$
I_{TL}	Logical 1-to-0 Transition Current (Port 1, 2, 3)			-650	μA	$V_{IN} = 2.0 \text{ V}$
R_{RST}	RST Pulldown Resistor	40		225	$k\Omega$	
C_{IO}	Pin Capacitance		10 (Note 4)		pF	$F_{OSC} = 16 \text{ MHz}$ $T_A = 25 \text{ }^\circ\text{C}$
I_{PD}	Powerdown Current		10 (Note 4)	20	μA	
I_{DL}	Idle Mode Current		12 (Note 4)	15	mA	$F_{OSC} = 16 \text{ MHz}$
I_{CC}	Operating Current		45 (Note 4)	80	mA	$F_{OSC} = 16 \text{ MHz}$

NOTES:

- Under steady-state (non-transient) conditions, I_{OL} must be externally limited as follows:
 - Maximum I_{OL} per port pin: 10 mA
 - Maximum I_{OL} per 8-bit port:
 - port 0 26 mA
 - ports 1–3 15 mA
 - Maximum Total I_{OL} for all output pins 71 mA

If I_{OL} exceeds the test conditions, V_{OL} may exceed the related specification. Pins are not guaranteed to sink current greater than the listed test conditions.
- Capacitive loading on ports 0 and 2 may cause spurious noise pulses above 0.4 V on the low-level outputs of ALE and ports 1, 2, and 3. The noise is due to external bus capacitance discharging into the port 0 and port 2 pins when these pins change from high to low. In applications where capacitive loading exceeds 100 pF, the noise pulses on these signals may exceed 0.8 V. It may be desirable to qualify ALE or other signals with a Schmitt trigger or CMOS-level input logic.
- Capacitive loading on ports 0 and 2 causes the V_{OH} on ALE and PSEN# to drop below the specification when the address lines are stabilizing.
- Typical values are obtained using $V_{CC} = 5.0$, $T_A = 25^\circ\text{C}$ and are not guaranteed.

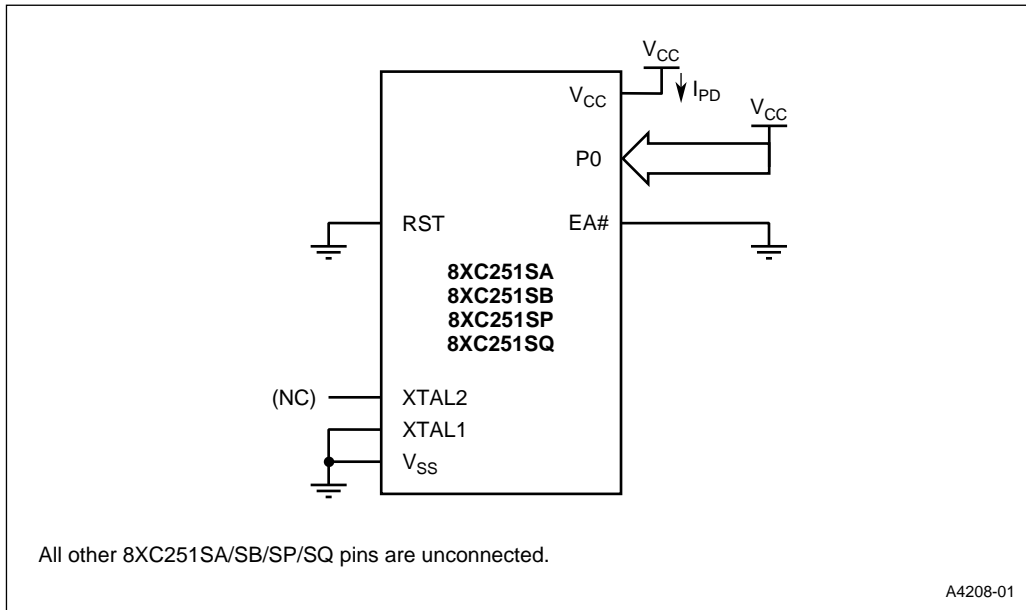

Figure 5. I_{PD} Test Condition, Powerdown Mode, $V_{CC} = 2.0 - 5.5V$

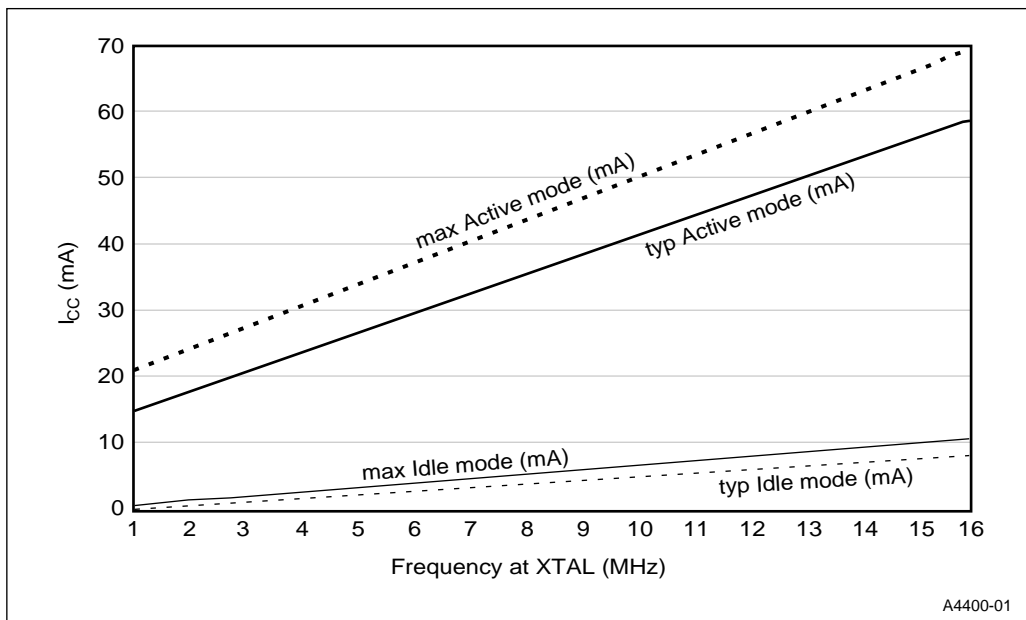

Figure 6. I_{CC} vs. Frequency (Mhz)



5.2 Definition of AC Symbols

Table 10. AC Timing Symbol Definitions

Signals		Conditions	
A	Address	H	High
D	Data In	L	Low
L	ALE	V	Valid
Q	Data Out	X	No Longer Valid
R	RD#/PSEN#	Z	Floating
W	WR#		

5.3 A.C. Characteristics

Test Conditions: Capacitive load on all pins = 50 pF.

Table 11 lists AC timing parameters for the 8XC251SA/SB/SP/SQ with no wait states. External wait states can be added by extending PSEN#/RD#/WR# and/or by extending ALE. In the table, Notes 3 and 5 mark parameters affected by an

ALE wait state, and Notes 4 and 5 mark parameters affected by a PSEN#/RD#/WR# wait state.

Figures 8–10 show the bus cycles with the timing parameters.

Table 11. AC Characteristics

Symbol	Parameter	@ Max F _{osc} (1)		F _{osc} Variable		Units
		Min	Max	Min	Max	
F _{osc}	XTAL1 Frequency	N/A	N/A	0	16	MHz
T _{osc}	1/F _{osc} @ 12 MHz @ 16 MHz	N/A	N/A	83.3 62.5		ns
T _{LHLL}	ALE Pulse Width @ 12 MHz @ 16 MHz	73.3 52.5		(1+2M) T _{osc} - 10		ns (3)
T _{AVLL}	Address Valid to ALE Low @ 12 MHz @ 16 MHz	58.3 37.5		(1+2M) T _{osc} - 25		ns (3)
T _{LLAX}	Address Hold after ALE Low @ 12 MHz @ 16 MHz	15 15		15		ns

NOTES:

- 16 MHz.
- Specifications for PSEN# are identical to those for RD#.
- In the formula, M=Number of wait states (0 or 1) for ALE.
- In the formula, N=Number of wait states (0,1,2, or 3) for RD#/PSEN#/WR#.
- “Typical” specifications are untested and not guaranteed.

Table 11. AC Characteristics (Continued)

Symbol	Parameter	@ Max F _{osc} (1)		F _{osc} Variable		Units
		Min	Max	Min	Max	
T _{RLRH} (2)	RD# or PSEN# Pulse Width @ 12 MHz @ 16 MHz	146.6 105		2(1+N) T _{OSC} - 20		ns (4)
T _{WLWH}	WR# Pulse Width @ 12 MHz @ 16 MHz	146.6 105		2(1+N) T _{OSC} - 20		ns (4)
T _{LLRL} (2)	ALE Low to RD# or PSEN# Low @ 12 MHz @ 16 MHz	58.3 37.5		T _{OSC} - 25		ns
T _{LHAX}	ALE High to Address Hold @ 12 MHz @ 16 MHz	83.3 62.5		(1+2M)T _{OSC}		ns (3)
T _{RLDV} (2)	RD#/PSEN# Low to valid Data/Instruction In @ 12 MHz @ 16 MHz		106.6 65		2(1+N) T _{OSC} - 60	ns (4)
T _{RHDx} (2)	Data/Instruction Hold Time. Occurs after RD#/PSEN# are exerted to V _{OH}	0		0		ns
T _{RLAZ} (2)	RD#/PSEN# Low to Address Float	Typ.=0 (5)	2	Typ. = 0 (5)	2	ns
T _{RHDZ1}	Instruction Float after RD#/PSEN# High commercial @ 12 MHz and 16 MHz express @ 12 MHz and 16 MHz	Typ.=2 5 Typ.=2 5 (5)	18 10	Typ.=25 Typ.=25 (5)	18 10	ns
T _{RHDZ2}	Data Float after RD#/PSEN# High @ 12 MHz @ 16 MHz		156.6 115		2T _{OSC} - 10	ns
T _{RHLH1}	RD#/PSEN# High to ALE High (Instruction) @ 12 MHz @ 16 MHz	10 10		10		ns
T _{RHLH2}	RD#/PSEN# High to ALE High (Data) @ 12 MHz @ 16 MHz	156.6 115		2T _{OSC} - 10		ns
T _{WHLH}	WR# High to ALE High @ 12 MHz @ 16 MHz	171.6 130		2T _{OSC} + 5		ns

NOTES:

- 16 MHz.
- Specifications for PSEN# are identical to those for RD#.
- In the formula, M=Number of wait states (0 or 1) for ALE.
- In the formula, N=Number of wait states (0,1,2, or 3) for RD#/PSEN#/WR#.
- "Typical" specifications are untested and not guaranteed.



Table 11. AC Characteristics (Continued)

Symbol	Parameter	@ Max F _{osc} (1)		F _{osc} Variable		Units
		Min	Max	Min	Max	
T _{AVDV1}	Address (P0) Valid to Valid Data/Instruction In @ 12 MHz @ 16 MHz		243.2 160		4(1+M/2) T _{OSC} - 90	ns (3)
T _{AVDV2}	Address (P2) Valid to Valid Data/Instruction In @ 12 MHz @ 16 MHz		268.2 185		4(1+M/2) T _{OSC} - 65	ns (3)
T _{AVDV3}	Address (P0) Valid to Valid Instruction In @ 12 MHz @ 16 MHz		116.6 75		2T _{OSC} - 50	ns
T _{AVRL} (2)	Address Valid to RD#/PSEN# Low @ 12 MHz @ 16 MHz	121.6 80		2(1+M) T _{OSC} - 45		ns (3)
T _{AVWL1}	Address (P0) Valid to WR# Low @ 12 MHz @ 16 MHz	126.6 85		2(1+M) T _{OSC} - 40		ns (3)
T _{AVWL2}	Address (P2) Valid to WR# Low @ 12 MHz @ 16 MHz	146.6 105		2(1+M) T _{OSC} - 20		ns (3)
T _{WHQX}	Data Hold after WR# High @ 12 MHz @ 16 MHz	63.3 42.5		T _{OSC} - 20		ns
T _{QVWH}	Data Valid to WR# High @ 12 MHz @ 16 MHz	138.6 97		2(1+N) T _{OSC} - 28		ns (4)
T _{WHAX}	WR# High to Address Hold @ 12 MHz @ 16 MHz	156.6 115		2T _{OSC} - 10		ns

NOTES:

- 16 MHz.
- Specifications for PSEN# are identical to those for RD#.
- In the formula, M=Number of wait states (0 or 1) for ALE.
- In the formula, N=Number of wait states (0,1,2, or 3) for RD#/PSEN#/WR#.
- "Typical" specifications are untested and not guaranteed.

5.3.1 EXTERNAL BUS CYCLES, NONPAGE MODE

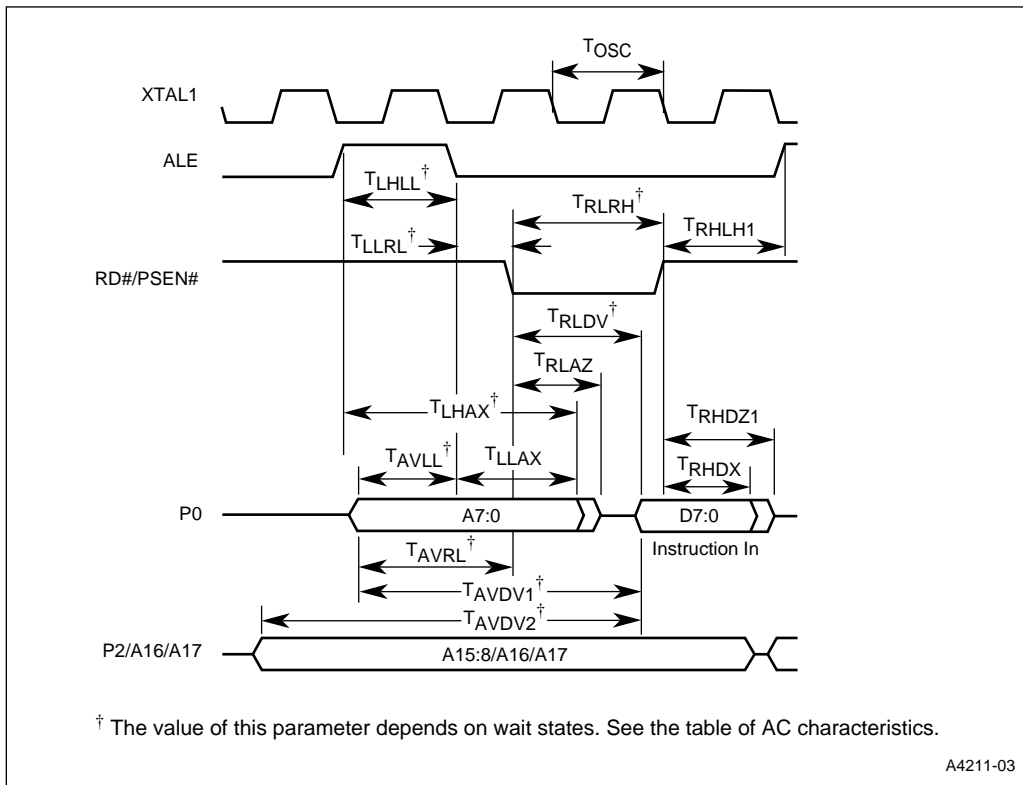

Figure 7. External Bus Cycle: Code Fetch (Nonpage Mode)

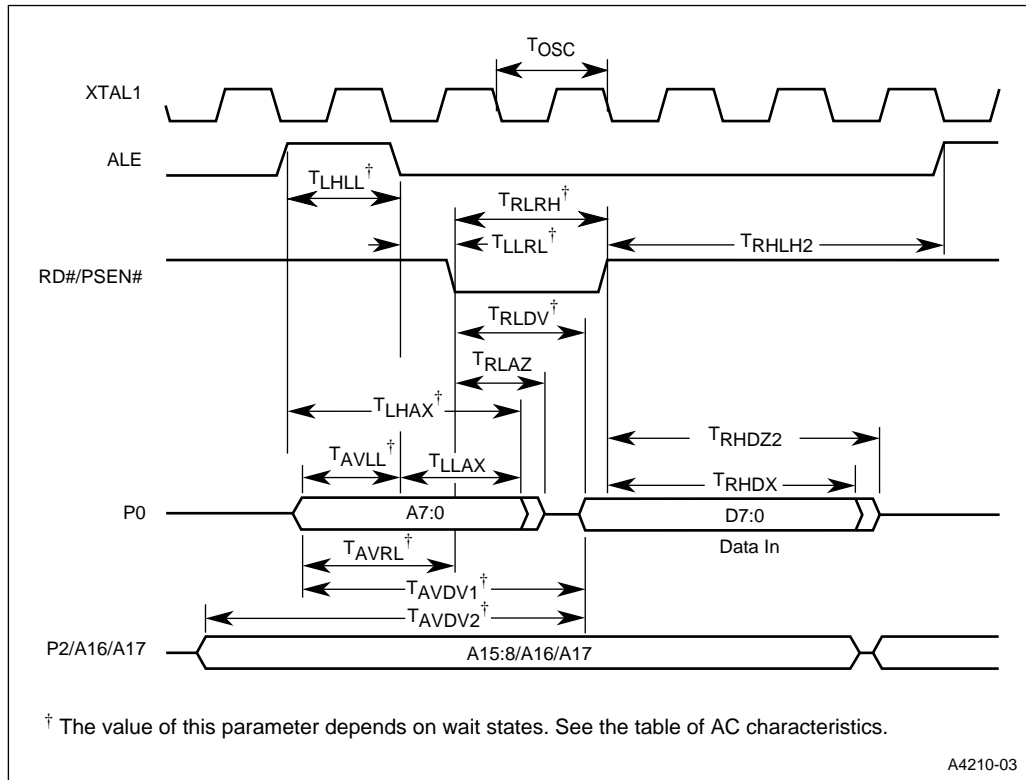

Figure 8. External Bus Cycle: Data Read (Nonpage Mode)

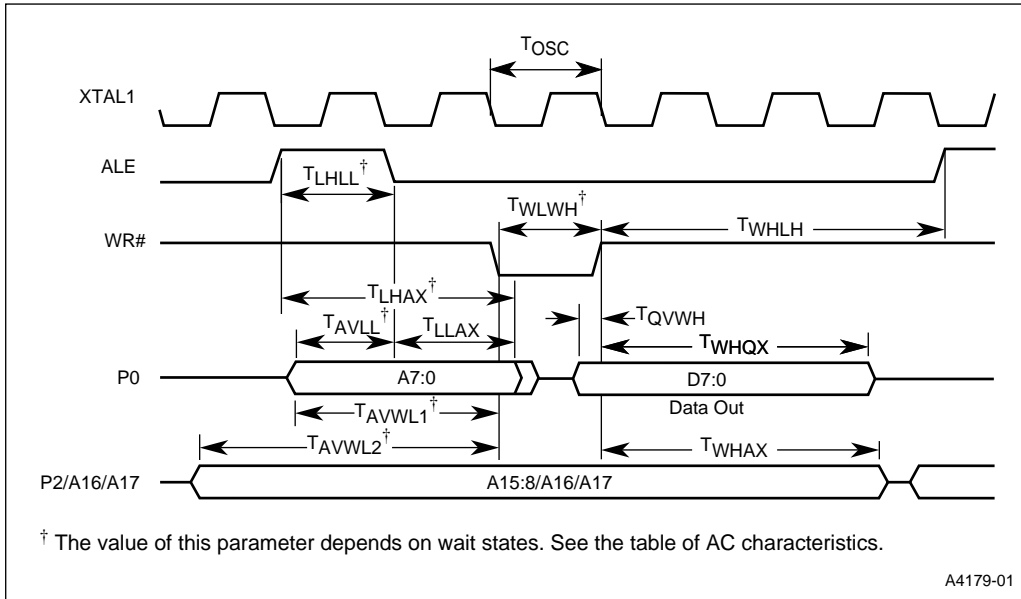

Figure 9. External Bus Cycle: Data Write (Nonpage Mode)

5.3.2 EXTERNAL BUS CYCLES, PAGE MODE

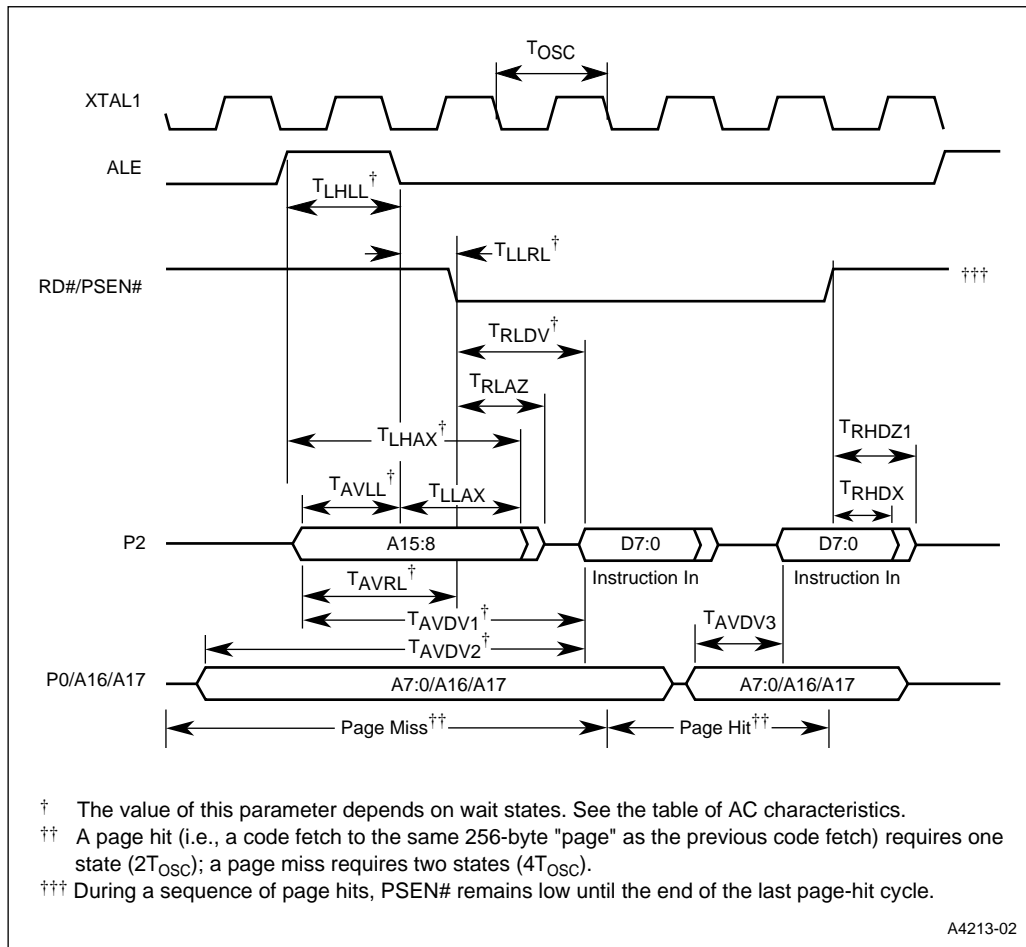

Figure 10. External Bus Cycle: Code Fetch (Page Mode)

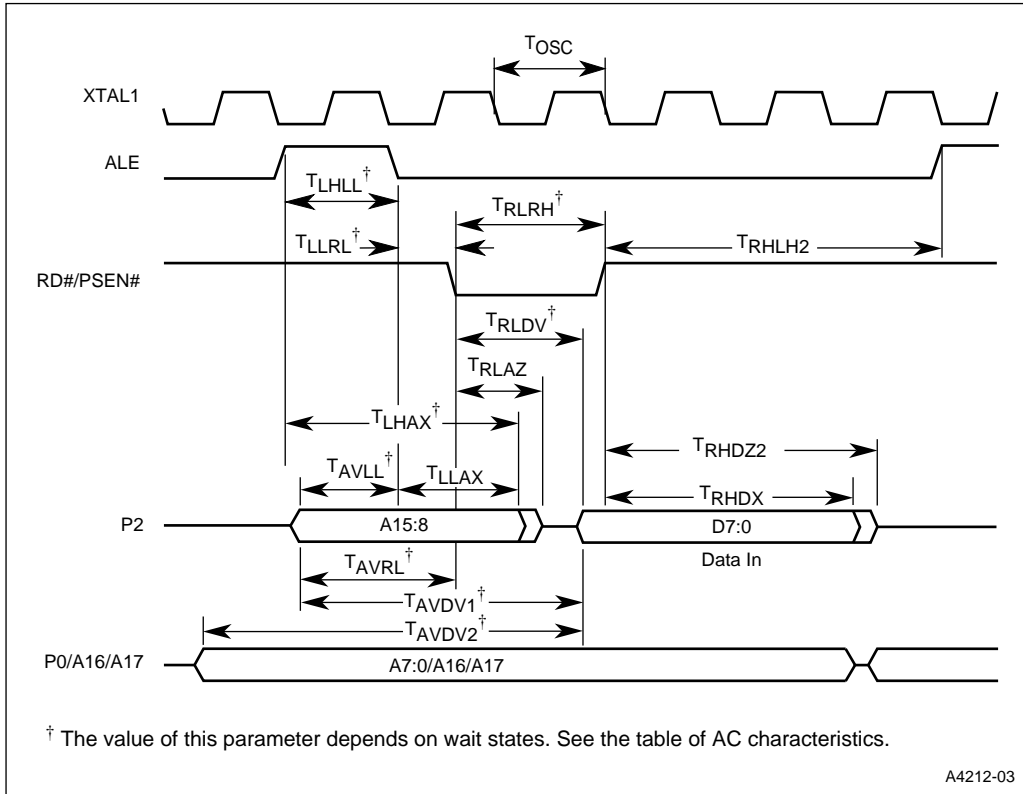

Figure 11. External Bus Cycle: Data Read (Page Mode)

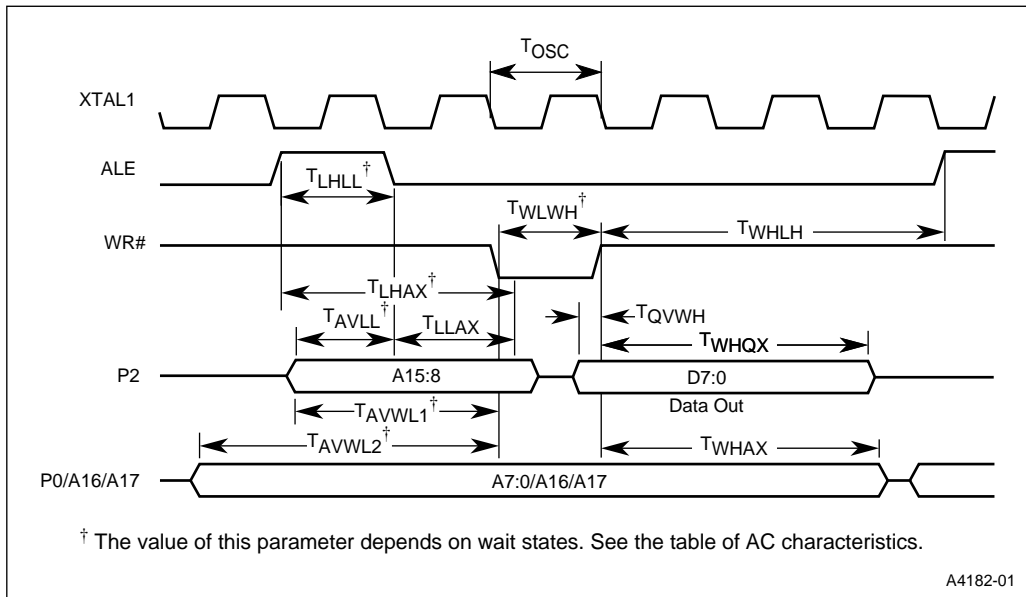

Figure 12. External Bus Cycle: Data Write (Page Mode)

5.3.3 DEFINITION OF REAL-TIME WAIT SYMBOLS

Table 12. Real-time Wait Timing Symbol Definitions

Signals		Conditions	
A	Address	L	Low
D	Data	X	Hold
C	WCLK	V	Setup
Y	WAIT#		
W	WR#		
R	RD#/PSEN#		

5.3.4 EXTERNAL BUS CYCLES, REAL-TIME WAIT STATES

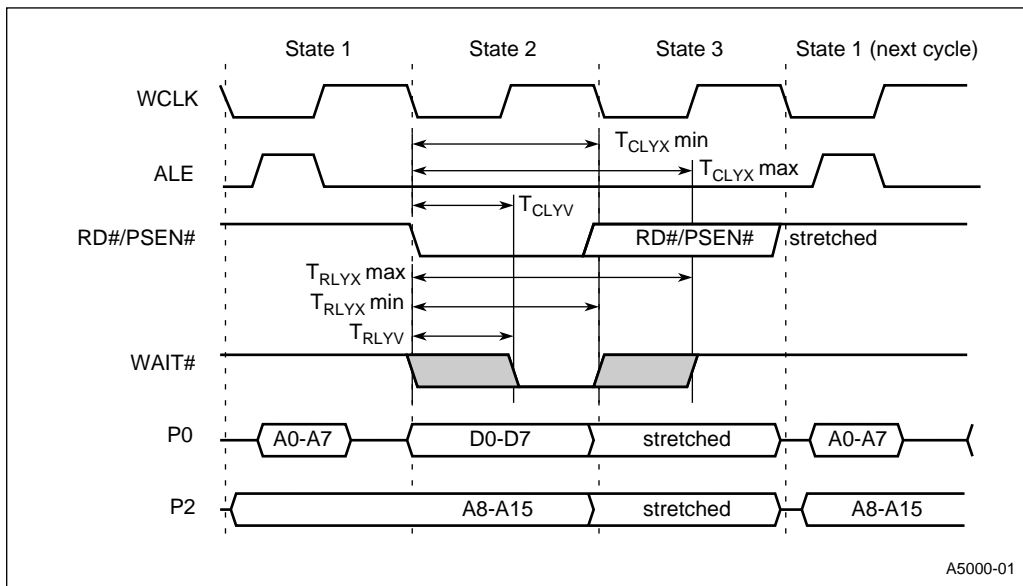

Figure 13. External Bus Cycle: Code Fetch/Data Read (Nonpage Mode)

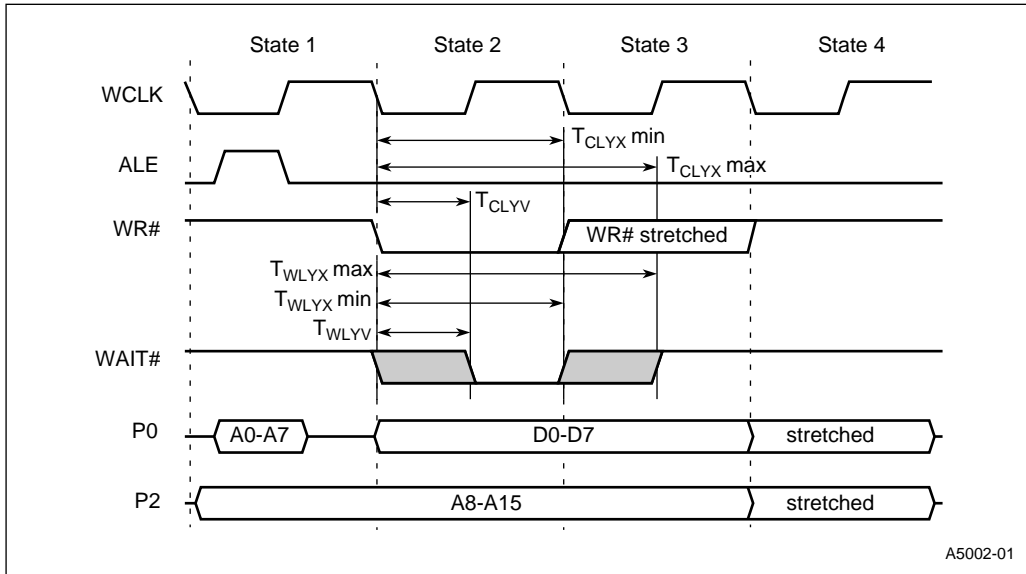

Figure 14. External Bus Cycle: Data Write (Nonpage Mode)

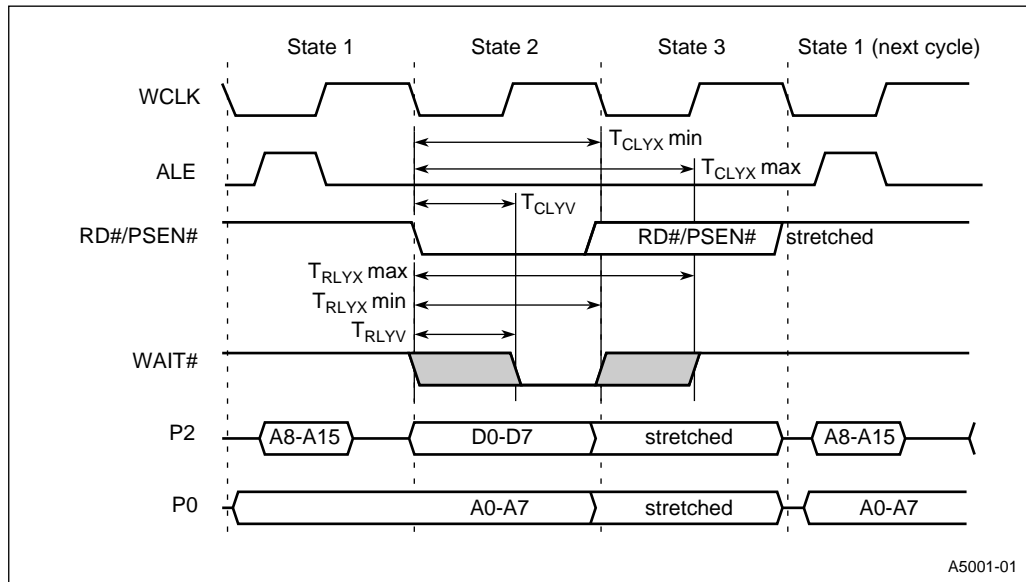

Figure 15. External Bus Cycle: Code Fetch/Data Read (Page Mode)

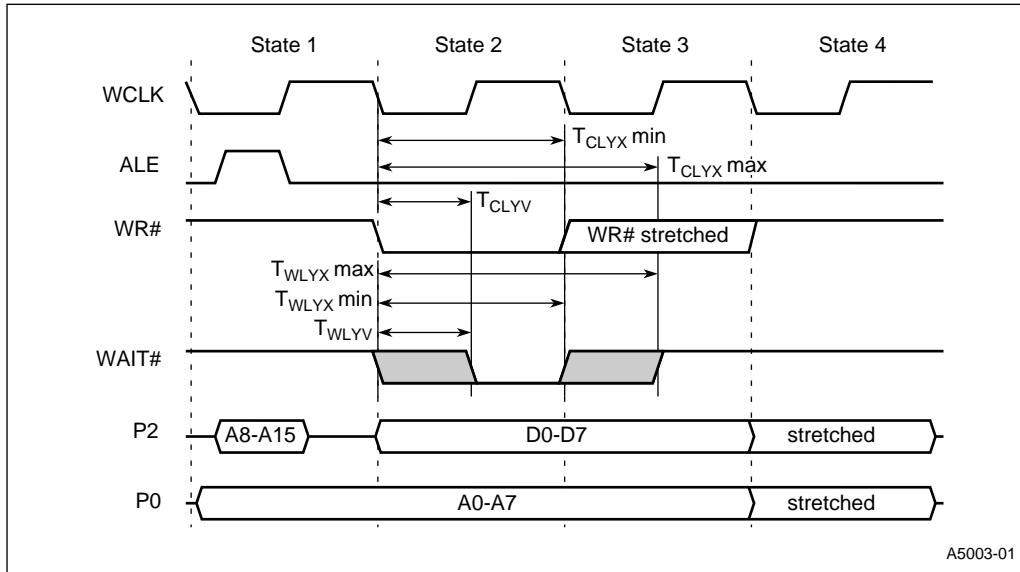

Figure 16. External Bus Cycle: Data Write (Page Mode)

Table 13. Real-time Wait AC Timing

Symbol	Parameter	Min	Max	Units
T_{CLYV}	Wait Clock Low to Wait Set-up	0	$T_{OSC} - 20$	ns
T_{CLYX}	Wait Hold after Wait Clock Low	$(2W)T_{OSC} + 5$	$(1+2W)T_{OSC} - 20$	ns
T_{RLYV}	PSEN#/RD# Low to Wait Set-up	0	$T_{OSC} - 20$	ns
T_{RLYX}	Wait Hold after PSEN#/RD# Low	$(2W)T_{OSC} + 5$	$(1+2W)T_{OSC} - 20$	ns
T_{WLYV}	WR# Low to Wait Set-up	0	$T_{OSC} - 20$	ns
T_{WLYX}	Wait Hold after WR# Low	$(2W)T_{OSC} + 5$	$(1+2W)T_{OSC} - 20$	ns

5.4 AC Characteristics — Serial Port, Shift Register Mode

Table 14. Serial Port Timing — Shift Register Mode

Symbol	Parameter	Min	Max	Units
T_{XLXL}	Serial Port Clock Cycle Time	$12T_{OSC}$		ns
T_{QVSH}	Output Data Setup to Clock Rising Edge	$10T_{OSC} - 133$		ns
T_{XHGX}	Output Data hold after Clock Rising Edge	$2T_{OSC} - 117$		ns
T_{XHDX}	Input Data Hold after Clock Rising Edge	0		ns
T_{XHDX}	Clock Rising Edge to Input Data Valid		$10T_{OSC} - 133$	ns

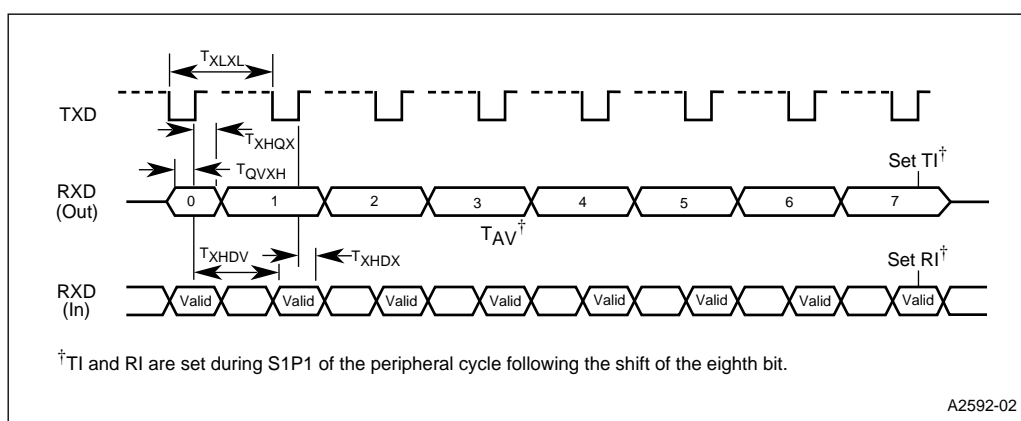

Figure 17. Serial Port Waveform — Shift Register Mode

5.5 External Clock Drive

Table 15. External Clock Drive

Symbol	Parameter	Min	Max	Units
$1/T_{CLCL}$	Oscillator Frequency (F_{OSC})		16	MHz
T_{CHCX}	High Time	20		ns
T_{CLCX}	Low Time	20		ns
T_{CLCH}	Rise Time		10	ns
T_{CHCL}	Fall Time		10	ns

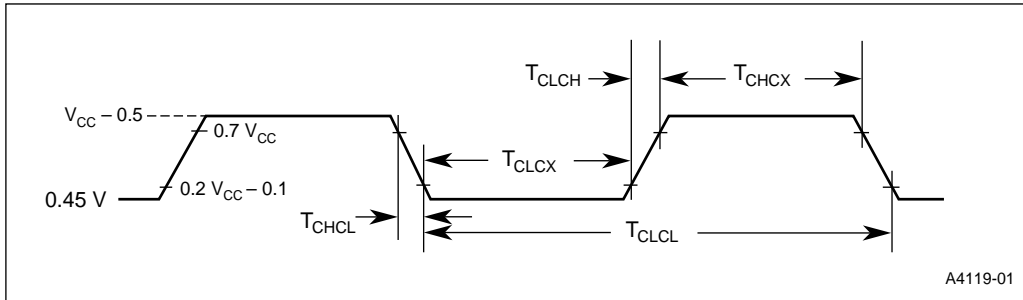

Figure 18. External Clock Drive Waveforms

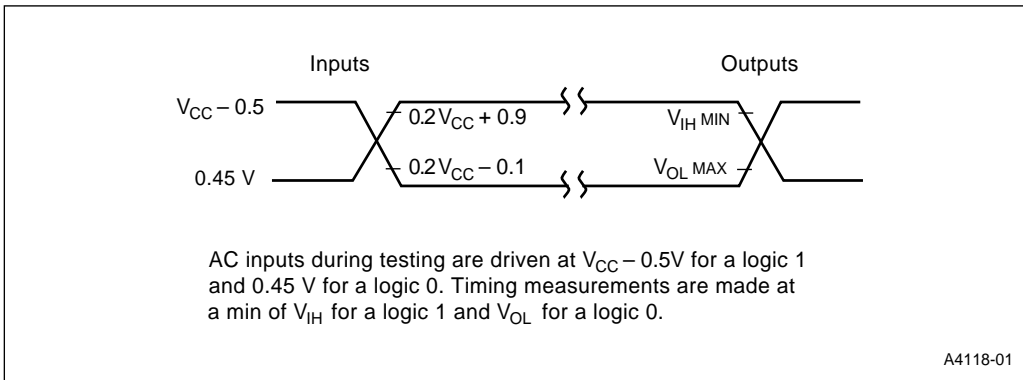

Figure 19. AC Testing Input, Output Waveforms

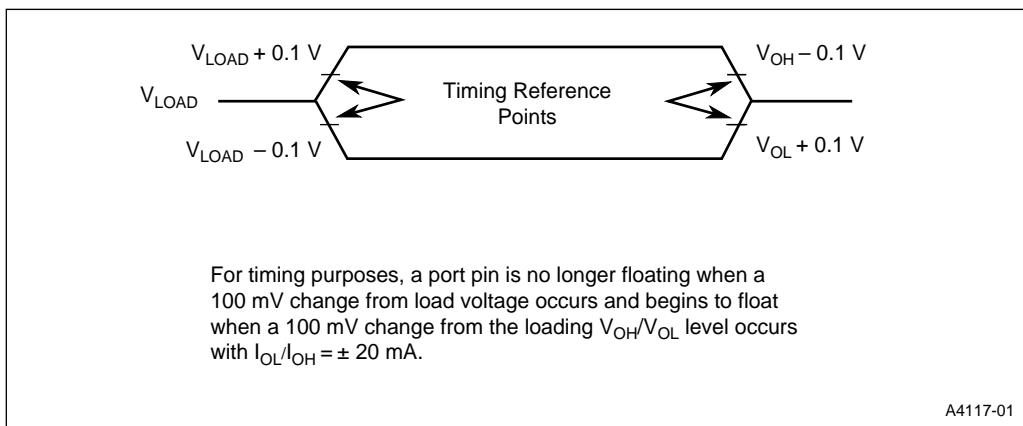

Figure 20. Float Waveforms

6.0 THERMAL CHARACTERISTICS

All thermal impedance data is approximate for static air conditions at 1 watt of power dissipation. Values change depending on operating conditions and application requirements. The Intel *Packaging Handbook* (order number 240800) describes Intel's thermal impedance test methodology.

Table 16. Thermal Characteristics

Package Type	θ_{JA}	θ_{JC}
44-pin PLCC	46°C/W	16°C/W
40-pin PDIP	45°C/W	16°C/W
40-pin Ceramic DIP	30.5°C/W	10°C/W

7.0 NONVOLATILE MEMORY PROGRAMMING AND VERIFICATION CHARACTERISTICS

7.1 Definition of Nonvolatile Memory Symbols

Table 17. Nonvolatile Memory Timing Symbol Definitions

Signals		Conditions	
A	Address	H	High
D	Data In	L	Low
Q	Data Out	V	Valid
S	Supply	X	No Longer Valid
G	PROG#	Z	Floating
E	Enable		

7.2 Programming and Verification Timing for Nonvolatile Memory

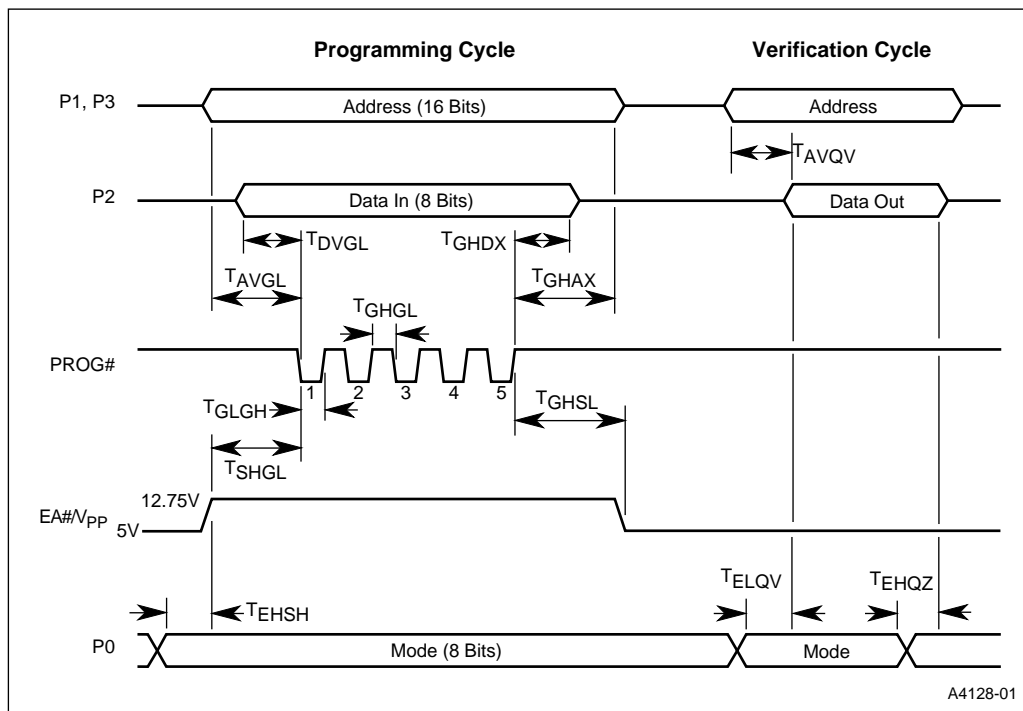

Figure 21. Timing for Programming and Verification of Nonvolatile Memory

Table 18. Nonvolatile Memory Programming and Verification Characteristics at $T_A = 21 - 27\text{ }^\circ\text{C}$, $V_{CC} = 5\text{ V}$, and $V_{SS} = 0\text{ V}$

Symbol	Definition	Min	Max	Units
V_{PP}	Programming Supply Voltage	12.5	13.5	D.C. Volts
I_{PP}	Programming Supply Current		75	mA
F_{OSC}	Oscillator Frequency	4.0	6.0	MHz
T_{AVGL}	Address Setup to PROG# Low	$48T_{OSC}$		
T_{GHAX}	Address Hold after PROG#	$48T_{OSC}$		
T_{DVGL}	Data Setup to PROG# Low	$48T_{OSC}$		
T_{GHDX}	Data Hold after PROG#	$48T_{OSC}$		
T_{EHS}	ENABLE High to V_{PP}	$48T_{OSC}$		
T_{SHGL}	V_{PP} Setup to PROG# Low	10		μs
T_{GHSL}	V_{PP} Hold after PROG#	10		μs
T_{GLGH}	PROG# Width	90	110	μs



Table 18. Nonvolatile Memory Programming and Verification Characteristics at $T_A = 21 - 27\text{ }^\circ\text{C}$, $V_{CC} = 5\text{ V}$, and $V_{SS} = 0\text{ V}$ (Continued)

T_{AVQV}	Address to Data Valid		$48T_{OSC}$	
T_{ELQV}	ENABLE Low to Data Valid		$48T_{OSC}$	
T_{EHQZ}	Data Float after ENABLE	0	$48T_{OSC}$	
T_{GHGL}	PROG# High to PROG# Low	10		μs

8.0 ERRATA

There are no known errata for this product.

9.0 REVISION HISTORY

This (-003) revision of the 8XC251SA/SB/SP/SQ datasheet contains information on products with "[M] [C] '94 '95 C" as the last line of the topside marking. This datasheet replaces earlier product information. The following changes appear in the -003 datasheet:

1. Real-time wait state operation is described in the datasheet.
2. Memory map reserved locations are newly defined and the Memory Map is now referred to as the "Address Map."
3. AC Characteristics have been updated. The following AC parameters have changed: T_{LLAX} , T_{RLRH} , T_{WLWH} , T_{LLRL} , T_{RLDV} , T_{RHDZ1} , T_{RHDZ2} , T_{RHLH2} , T_{WHLH} , T_{AVDV1} , T_{AVDV2} , T_{AVRL} , T_{AVWL1} , T_{AVWL2} , T_{QVWH} , and T_{WHAX} .
4. DC Characteristics have been updated. The following DC specs have changed: I_{PD} max, I_{DL} typical, I_{DL} max, I_{CC} typical, and I_{CC} max.
5. An I_{CC} vs. Frequency graph is included.
6. Process information is no longer contained in the datasheet.
7. The section "Programming and Verifying Nonvolatile Memory" has been deleted. See the 8XC251SA/SB/SP/SQ Embedded Microcontroller User's Manual. Timing and Characteristics for Programming and Verifying Nonvolatile

8. Signature Byte information has been deleted. See the 8XC251SA/SB/SP/SQ Embedded Microcontroller User's Manual.
9. Sections in the datasheet are numbered.
10. New sections have been created to provide better organization. These include "Nomenclature," "Pinout," "Signals," "Address Map," "Electrical Characteristics," "Thermal Characteristics," "Nonvolatile Memory Programming and Verification Characteristics," "Errata," and "Revision History"
11. Proliferation Options and Package Options are in the Nomenclature section.
12. Temperature range is contained in the Electrical Characteristics section under "Operating Conditions"
13. Bus timing diagrams have been organized into subsections.

The (-002) revision of the 8XC251SA/SB/SP/SQ datasheet contains information on products with "[M] [C] '94 '95 B" as the last line of the topside marking. This datasheet replaces earlier product information. The following changes appear in the -002 datasheet:

1. A corrected PDIP diagram appears on page 7.
2. A corrected formula to calculate T_{LHLL} is described on page 17.
3. The RD#/PSEN# waveform is changed in Figure 11 on page 25.