

RTD2523B/2513B/2023B/2013B

Flat Panel Display Controller

Fully Technology

Revision

Version 1.01

Last updated: 2005/3/1

Realtek Confidential

1. FEATURES..... 6

2. CHIP DATA PATH BLOCK DIAGRAM.....18

3. Architecture19

4. FUNCTIONAL DESCRIPTION.....20

4.1 INPUT20

Digital Input (ITU 656).....20

Analog Input22

TMDS Input (Optional).....22

Input Capture Window23

4.2 OUTPUT TIMING24

Display Output Timing.....24

Display Active Window27

4.3 COLOR PROCESSING28

4.4 OSD & COLOR LUT28

Build-In OSD28

Color LUT & Overlay Port.....28

4.5 AUTO-ADJUSTMENT30

Auto-Position30

Auto-Tracking30

4.6 PLL SYSTEM30

DCLK PLL.....30

M2PLL.....31

ADC Pixel Sampling PLL31

4.7 HOST INTERFACE.....32

Parallel/Serial Port Determination:32

Host Interface Location Determination:.....32

Double Data Rate Serial/Parallel Interface:.....33

4.9 THE PROGRAMMABLE SCHMITT TRIGGER OF HSYNC35

4.10 CRYSTAL FREQUENCY OUTPUT35

THIS PAGE IS LEFT FOR BLANK5. REGISTER DESCRIPTION.....36

5. REGISTER DESCRIPTION.....37

GLOBAL EVENT FLAG37

INPUT VIDEO CAPTURE40

Capture Format40

Input Frame Window (All capture window setting unit is 1).....44

FIFO Window47

DIGITAL FILTER47

SCALING UP FUNCTION49

SCALING DOWN CONTROL54

DISPLAY FORMAT56

FRAME SYNC FINE TUNE61

DISPLAY FINE TUNE62

SYNC PROCESSOR.....64

Y-PB-PR CONTROL.....66

COLOR PROCESSOR CONTROL.....71

Brightness Coefficient:.....72

Contrast Coefficient:.....73

Gamma Control73

Dithering Control.....74

OVERLAY/COLOR PALETTE/BACKGROUND COLOR CONTROL77

IMAGE AUTO FUNCTION78

VIDEO (COLOR SPACE CONVERSION)82

EMBEDDED TIMING CONTROLLER.....84

Anti-Flicker Control.....86

RSDS Display Data Bus Control87
TCON Horizontal/Vertical Timing Setting87
Dot masking90
CONTROL FOR LVDS93
PIN SHARE.....97
EMBEDDED OSD100
RESET OUT AND PANEL SWITCH MOS CONTROL101
SCHMITT TRIGGER CONTROL101
PHASE-LOCK-LOOP (PLL)103
DDS Setting for ADC103
ADC PLL1107
ADC PLL2108
DISPLAY PLL111
MULTIPLY PLL FOR INPUT CYRSTAL113
PLL TEST.....114
DCLK SPREAD SPECTRUM115
EMBEDDED TMDS (OPTIONAL)118
HDCP (ONLY IN H SERIES)128
WATCH DOG132
MACRO VISION133
EMBEDDED ADC.....134
CYCLIC-REDUNDANT-CHECK.....140
DDC SPECIAL FUNCTION ACCESS (DDC/CI)141
DDC CHANNEL (ADC/DVI)144
EMBEDDED OSD146
6. ELECTRIC SPECIFICATION.....186
 DC CHARACTERISTICS186
7. MECHANICAL SPECIFICATION.....187

Realtek Confidential

Revision History

Ver 1.01	1/3/2005			Initial release

Realtek Confidential

Overview

Realtek RTD2523B series products are all-in-one LCD monitor controllers support up to SXGA/XGA(optional), and integrate Realtek high performance ADC, TMDS Rx(optional), scaling engine, OSD engine, LVDS TX, RSDS TX and so on. Moreover, all products are pin compatible in low pin count package to save cost and make the design easier. The RTD2523B series derivative pin compatible products are listed below by application:

Part Number	ADC	DVI	HDCP	Resolution	Output	Package
RTD2523B	160MHz	Yes	No	SXGA	LVDS/RSDS/TTL	128 PQFP
RTD2513B	110MHz	Yes	No	XGA	LVDS/RSDS/TTL	128 PQFP
RTD2023B	160MHz	No	No	SXGA	LVDS/RSDS/TTL	128 PQFP
RTD2013B	110MHz	No	No	XGA	LVDS/RSDS/TTL	128 PQFP
RTD2523BH	160MHz	Yes	Yes	SXGA	LVDS/RSDS/TTL	128 PQFP
RTD2513BH	110MHz	Yes	Yes	XGA	LVDS/RSDS/TTL	128 PQFP

Note:

The following datasheet will take RTD2523B as an example and if it exists any optional feature not supported in all RTD2523B series products, we will mark “optional” after it.

1. Features

General

- | Embedded dual DDC with DDC1/2B/CI, fully compatible with Portrait Display
- | Zoom scaling up and down
- | No external memory required.
- | Require only one crystal to generate all timing.
- | Programmable 3.3V/5V detection reset output.
- | Embedded crystal output to micro-controller.
- | 3 channels 8 bits PWM output, and wide range selectable PWM frequency.

Analog RGB Input Interface

- | Integrated 8-bit triple-channel 165/110 Mhz (Optional) ADC/PLL
- | Embedded programmable Schmitt trigger of HSYNC
- | Support Sync On Green (SOG) and various kinds of composite sync modes
- | On-chip high-performance hybrid PLLs
- | High resolution true 64 phase ADC PLL
- | Support 2 Analog input support switch

Digital Video Input Interface

- | Support 8-bit video (ITU 656) format input
- | Built-in YUV to RGB color space converter (ITU656 or ITU601) & de-interlace

DVI Compliant Digital Input Interface (Optional)

- | Single link on-chip TMDS receiver
- | Long cable 25M support to 135Mhz, 165Mhz with typical length (2M)
- | Adaptive algorithm for TMDS capability
- | Data enable only mode support
- | High-Bandwidth Digital Content Protection (HDCP) (Only in H version)
- | Enhanced protection of HDCP secret key (Only in H version)

Auto Detection /Auto Calibration

- | Input format detection
- | Compatibility with standard VESA mode and support user-defined mode
- | Smart engine for Phase/Image position/Color calibration

Scaling

- | Fully programmable zoom ratios
- | Independent horizontal/vertical scaling
- | Advanced zoom algorithm provides high image quality
- | Sharpness/Smooth filter enhancement
- | Support non-linear scaling from 4:3 to 16:9 or 16:9 to 4:3

Color Processor

- | True 10 bits color processing engine
- | sRGB compliance
- | Advanced Dithering logic for 18-bit panel color depth enhancement
- | Content adaptive edge enhancement.
- | Dynamic overshoot-smear canceling engine
- | Brightness and contrast control
- | Programmable 10-bit gamma support

Output Interface

- | Fully programmable display timing generator
- | Flexible data pair swapping for easier system design.
- | Programmable TCON function support
- | Multi-output interface (RSDS/LVDS/TTL) on single PCB
- | Spread-Spectrum DPLL to reduce EMI
- | Fixed Last Line output for perfect panel capability

Host Interface

- | Support MCU serial/parallel bus interface.
- | Support MCU dual edge data latch.

Embedded OSD

- | Embedded 12K SRAM dynamically stores OSD command and fonts
- | Support multi-color RAM font, 1, 2 and 4-bit per pixel
- | 16 color palette with 24bit true color selection
- | Maximum 8 window with alpha-blending/gradient/dynamic fade-in/fade-out, bordering/shadow/3D window type
- | Every window can place anywhere on the screen
- | Rotary 90,180,270 degree
- | Independent row shadowing/bordering
- | Programmable blinking effects for each character
- | OSD-made internal pattern generator for factory mode
- | Support 12x18~4x18 proportional font

Power & Technology

- | 3.3V power supplier
- | 0.18um CMOS process, 128-pin QFP package
- | Embedded 3.3V to 1.8V voltage regulator
- | Embedded 3.3V MOS panel switch

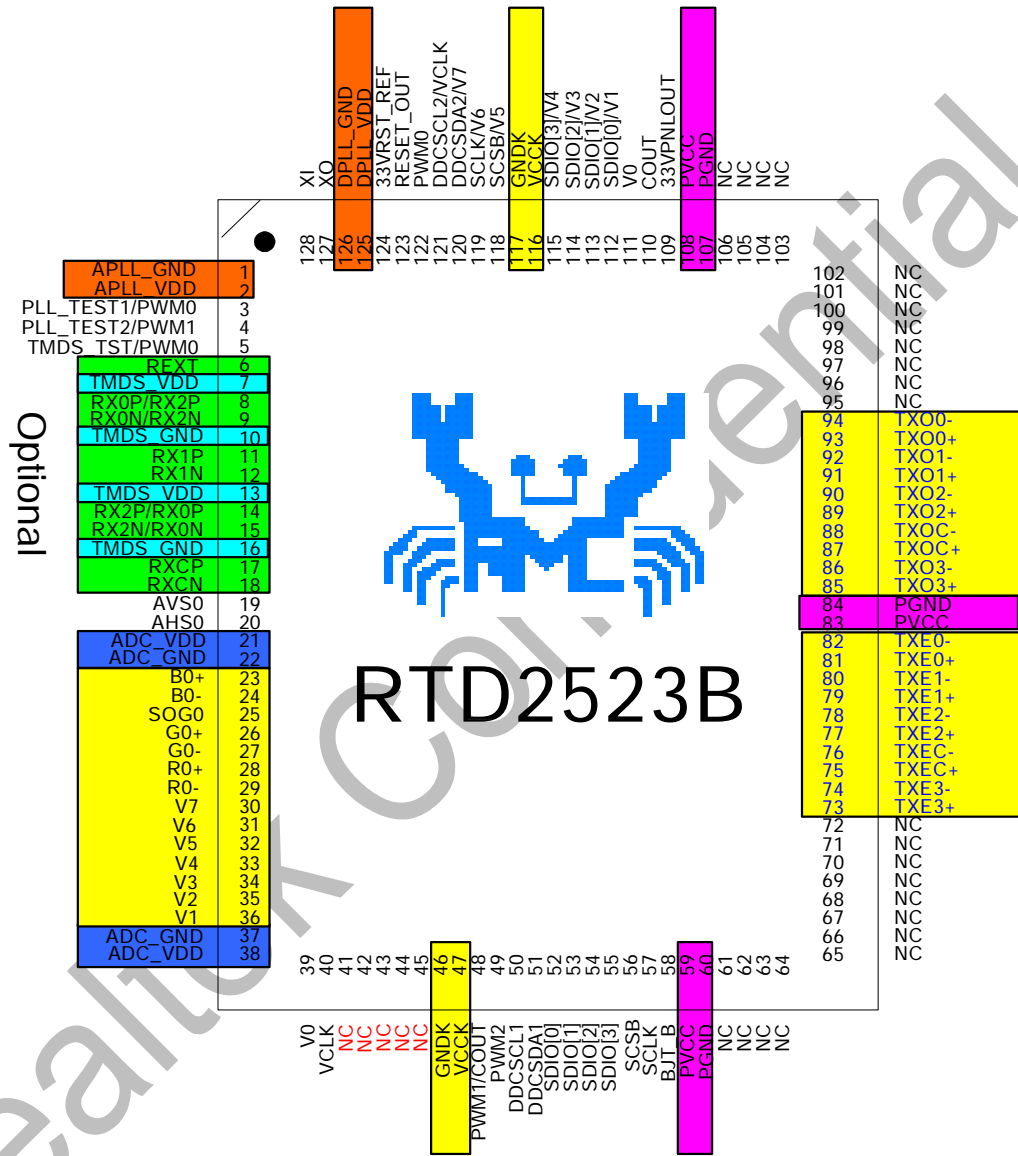

A+ D+ Video with LVDS

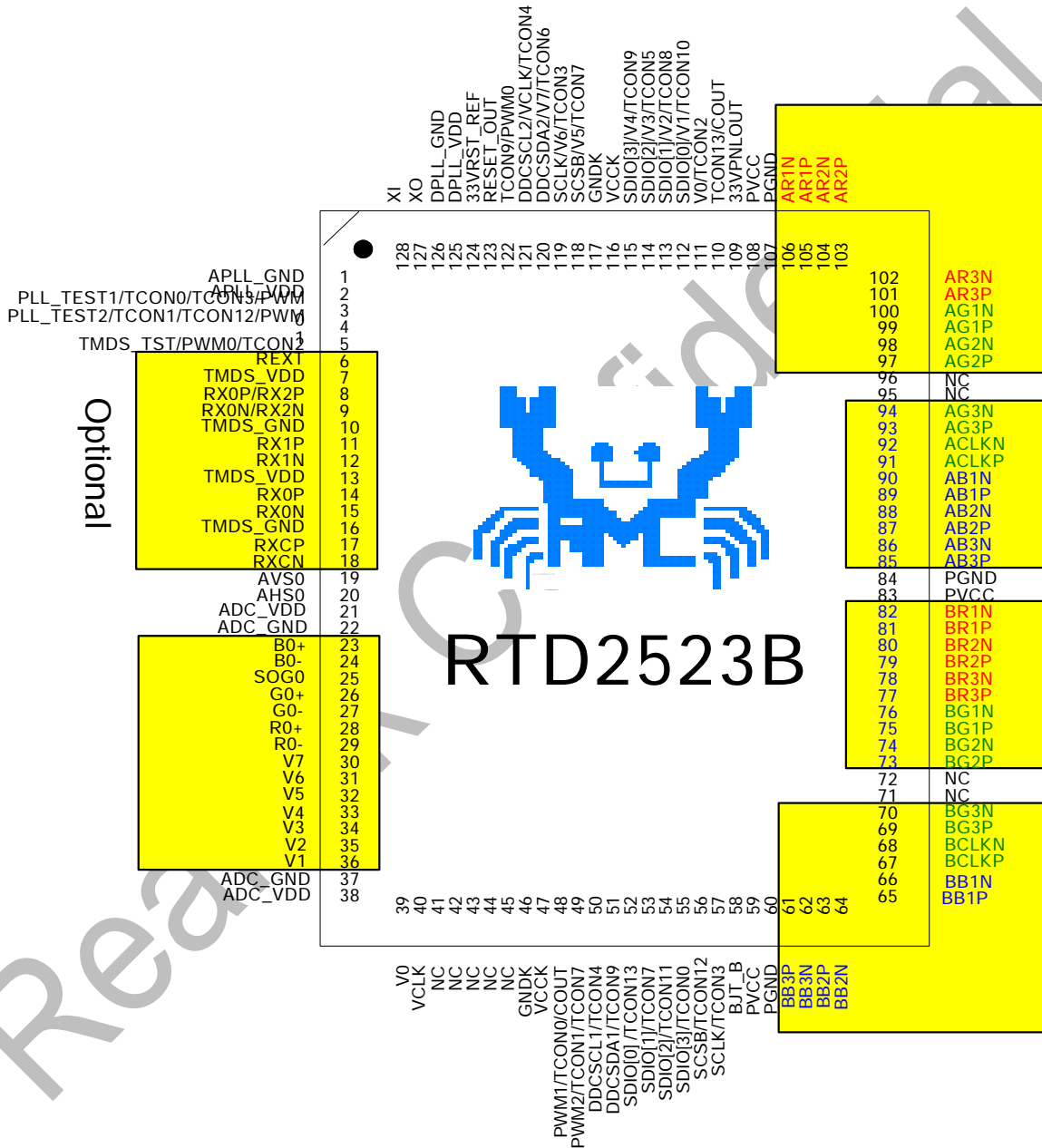

A+ D+ Video with Type-III RSDS

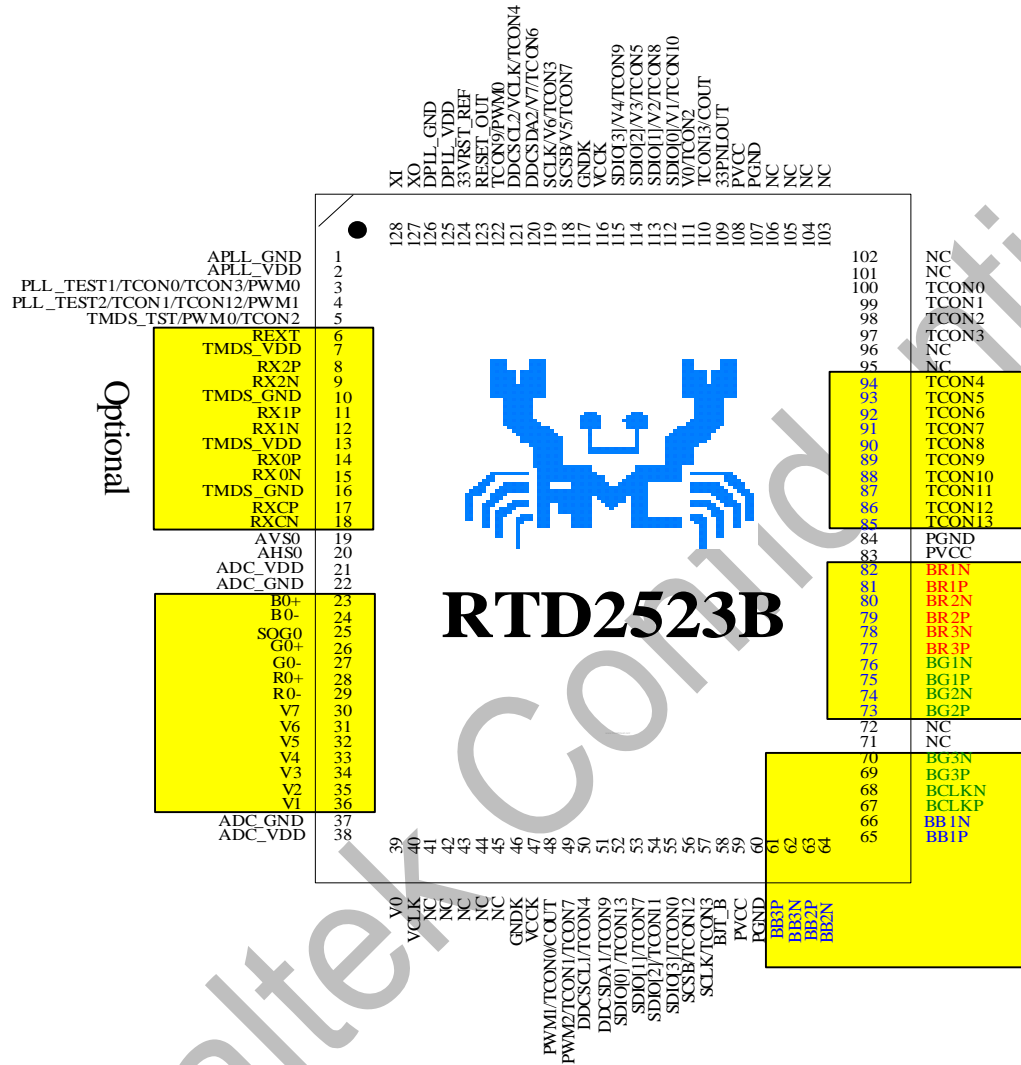

A+ D+ Video with Type I RSDS/8TCONs¹ output

¹For CPT panel, output interface has 7 TCON pins, for Hannstar panel, it has 8 output TCON pins.

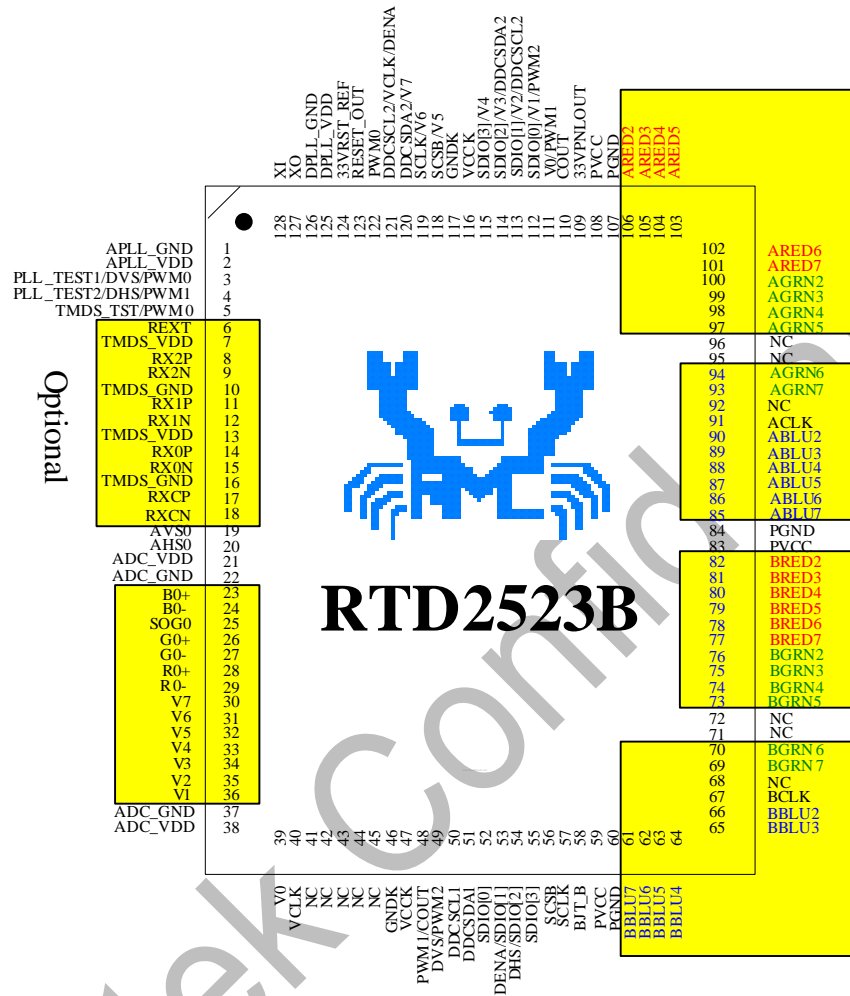

A+ D+ Video with H/V/DEN 6-bit TTL

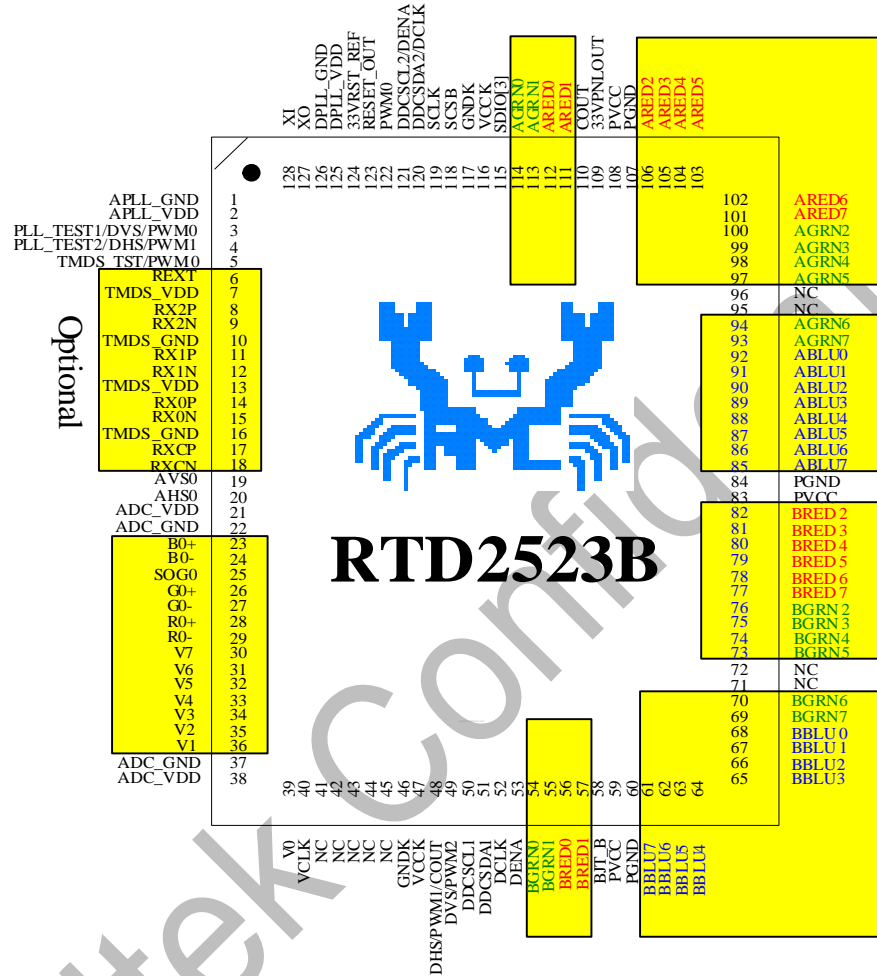

A+ D+ Video with H/V/DEN 8-bit TTL

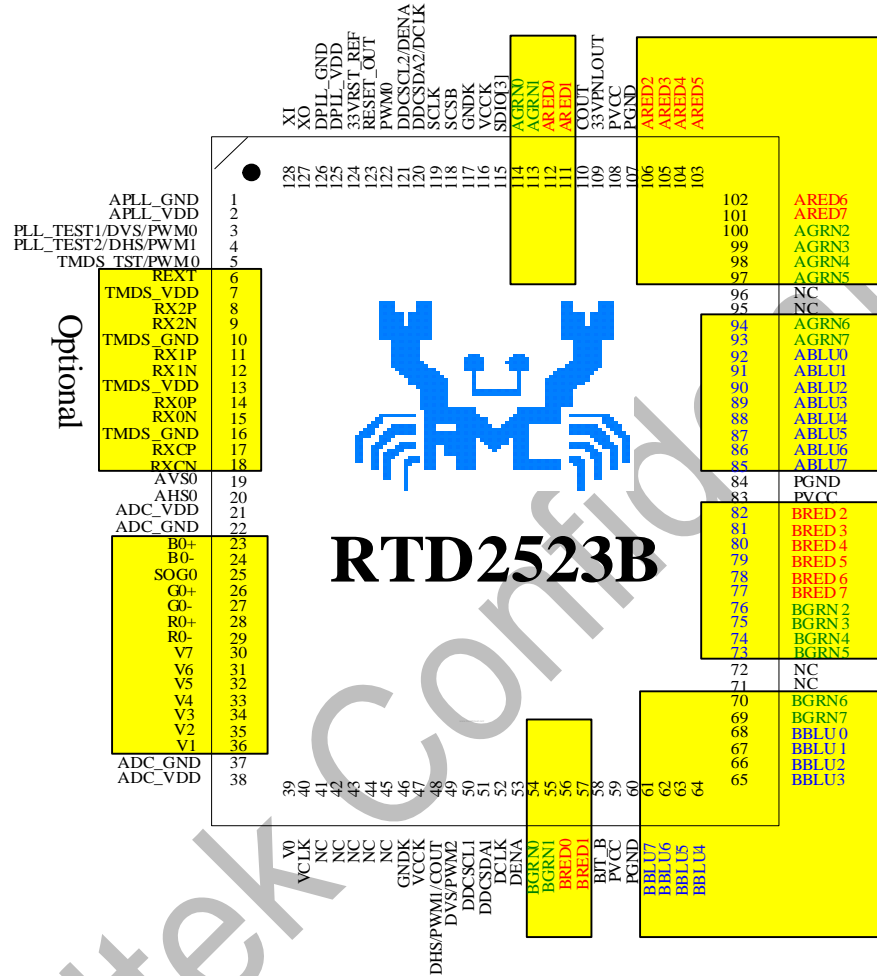

A+ D+ Video with smart panel 6-bit TTL

(I/O Legend: A = Analog, I = Input, O = Output, P = Power, G = Ground)

n INPUT PORT

Name	I/O	No	Description	Note
ADC_GND	AG	22	ADC Ground	
ADC_GND	AG	37	ADC Ground	
B0+	AI	23	1 st Positive BLUE analog input (Pb+)	
B0-	AI	24	1 st Negative BLUE analog input (Pb-)	
SOG0	AI	25	1 st Sync on Green	
G0+	AI	26	1 st Positive GREEN analog input (Y+)	
G0-	AI	27	1 st Negative GREEN analog input (Y-)	
R0+	AI	28	1 st Positive RED analog input (Pr+)	
R0-	AI	29	1 st Negative RED analog input (Pr-)	
ADC_VDD	AP	21	ADC Power	(1.8V)
ADC_VDD	AP	38	ADC Power	(1.8V)
V7	AI/I	30	Video8 bit 7	
V6	AI/I	31	Video8 bit 6	
V5	AI/I	32	Video8 bit 5	
V4	AI/I	33	Video8 bit 4	
V3	AI/I	34	Video8 bit 3	
V2	AI/I	35	Video8 bit 2	
V1	AI/I	36	Video8 bit 1	
V0	AI/I	39	Video8 bit 0	
VCLK	AI/I	40	Video8 Clock	
AVS0	I	19	ADC vertical sync input 5V tolerance Power from PIN 13	
AHS0	I	20	ADC horizontal sync input Adjustable Schmidt trigger 5V tolerance Power from PIN 13	

n PLL

Name	I/O	Pin No	Description	Note
XO	AO	127	Crystal OSC output	
XI	AI	128	Reference clock input from external crystal or from single-ended CMOS/TTL OSC	3.3V tolerance
DPLL_GND	AG	126	Ground for display digital PLL	
DPLL_VDD	AP	125	Power for digital PLL	3.3V
APLL_VDD	AP	2	Power for multi-phase PLL	3.3V
PLL_TEST1	I/O	3	Test Pin 1 Power-on-latch for MCU crystal location	
PLL_TEST2	I/O	4	Test Pin 2 Power-on-latch for crystal in frequency	M2PLL Selection
APLL_GND	AG	1	Ground for multi-phase PLL	

n Host interface

Name	I/O	Pin No	Description	Note
SDIO[0]	I/O	52/112	Parallel port data [0] (Open drain)LSB	
SDIO[1]	I/O	53/113	Parallel port data [1] (Open drain)	
SDIO[2]	I/O	54/114	Parallel port data [2] (Open drain)	
SDIO[3]	I/O	55/115	Serial control I/F data in or Parallel port data [3] (Open drain) MSB	
SCSB	O	56/118	Serial control I/F chip select (Open drain)	
SCLK	O	57/119	Serial control I/F clock (Open drain)	

n TMDS: (Optional)

Name	I/O	Pin No	Description	Note
TMDS_TST	AIO	5	TMDS_TEST Pin Power-on-latch for host interface type	
REXT	AI	6	Impedance Match Reference.	
TMDS_VDD	AP	7	TMDS power	(3.3V)
RX2P	AI	8	Differential Data Input	
RX2N	AI	9	Differential Data Input	
TMDS_GND	AG	10	TMDS ground	
RX1P	AI	11	Differential Data Input	
RX1N	AI	12	Differential Data Input	
TMDS_VDD	AP	13	TMDS power	(3.3V)
RX0P	AI	14	Differential Data Input	
RX0N	AI	15	Differential Data Input	
TMDS_GND	AG	16	TMDS ground	
RXCP	AI	17	Differential Data Input	
RXCN	AI	18	Differential Data Input	

n Pad/Digital Power & Ground

Name	I/O	Pin No	Description
Pad 3.3V Power	P	59/83/108	PVCC
Pad 3.3V Ground	G	60/84/107	PGND
Digital 1.8V Power	P	47/116	VCCK
Digital 1.8V Ground	G	46/117	GNDK

n LVDS Display Interface

Name	I/O	No	Description
TXE3+	O	73	
TXE3-	O	74	
TXEC+	O	75	
TXEC-	O	76	
TXE2+	O	77	
TXE2-	O	78	
TXE1+	O	79	
TXE1-	O	80	
TXE0+	O	81	
TXE0-	O	82	
TXO3+	O	85	
TXO3-	O	86	
TXOC+	O	87	
TXOC-	O	88	
TXO2+	O	89	
TXO2-	O	90	
TXO1+	O	91	
TXO1-	O	92	
TXO0+	O	93	
TXO0-	O	94	

n RSDS Display Interface

Name	I/O	No	Description
BB3P	O	61	
BB3N	O	62	
BB2P	O	63	
BB2N	O	64	

BB1P	O	65	
BB1N	O	66	
BCLKP	O	67	
BCLKN	O	68	
BG3P	O	69	
BG3N	O	70	
BG2P	O	73	
BG2N	O	74	
BG1P	O	75	
BG1N	O	76	
BR3P	O	77	
BR3N	O	78	
BR2P	O	79	
BR2N	O	80	
BR1P	O	81	
BR1N	O	82	
AB3P	O	85	
AB3N	O	86	
AB2P	O	87	
AB2N	O	88	
AB1P	O	89	
AB1N	O	90	
ACLKP	O	91	
ACLKN	O	92	
AG3P	O	93	
AG3N	O	94	
AG2P	O	97	
AG2N	O	98	
AG1P	O	99	
AG1N	O	100	
AR3P	O	101	
AR3N	O	102	
AR2P	O	103	
AR2N	O	104	
AR1P	O	105	
AR1N	O	106	

n TTL 8/6 bits Interface

Name	I/O	No	Description
BBLU7	O	61	
BBLU6	O	62	
BBLU5	O	63	
BBLU4	O	64	
BBLU3	O	65	
BBLU2	O	66	
BBLU1/NC	O	67	
BBLU0/NC	O	68	
BGRN7	O	69	
BGRN6	O	70	
BGRN5	O	73	
BGRN4	O	74	
BGRN3	O	75	
BGRN2	O	76	
BGRN1/NC	O	55	

BGRN0/NC	O	54	
BRED7	O	77	
BRED6	O	78	
BRED5	O	79	
BRED4	O	80	
BRED3	O	81	
BRED2	O	82	
BRED1/NC	O	57	
BRED0/BCLK	O	56	
ABLU7	O	85	
ABLU6	O	86	
ABLU5	O	87	
ABLU4	O	88	
ABLU3	O	89	
ABLU2	O	90	
ABLU1/ACLK	O	91	
ABLU0/NC	O	92	
AGRN7	O	93	
AGRN6	O	94	
AGRN5	O	97	
AGRN4	O	98	
AGRN3	O	99	
AGRN2	O	100	
AGRN1/NC	O	113	
AGRN0/NC	O	114	
ARED7	O	101	
ARED6	O	102	
ARED5	O	103	
ARED4	O	104	
ARED3	O	105	
ARED2	O	106	
ARED1/NC	O	111	
ARED0/NC	O	112	

n Timing Controller

Name	I/O	No	Description
TCON0	O	3/55/47/100	Refer to Pin share part.
TCON1	O	49/99/4	
TCON2	O	5/98/111	
TCON3	O	3/57/97/119	
TCON4	O	50/94/110/121	
TCON5	O	93/114	
TCON6	O	92/120	
TCON7	O	49/52/91/118	
TCON8	O	90/113	
TCON9	O	51/89/115/122	
TCON10	O	88/112	
TCON11	O	54/87	
TCON12	O	4/56/86	
TCON13	O	52/85	

n DDC Channel

Name	I/O	No	Description
DDCSCL1(ADC)	I	50	Open drain (Internal 75K pull high)

DDCSDA1(ADC)	I/O	51	Open drain (Internal 75K pull high)
DDCSCL2(DVI)	I	121	Open drain (Internal 75K pull high)
DDCSDA2(DVI)	I/O	120	Open drain (Internal 75K pull high)

n PWM

Name	I/O	No	Description
PWM0	O	3/5/122	
PWM1	O	4/48/111	
PWM2	O	49/112	

n MISC

Name	I/O	No	Description
RESET_OUT	O	123	Reset out Open drain (Internal 75KOhm high)
COUT	O	110/48	Crystal out
33VRST_REF	I	124	Reference 3.3V for Reset Out
33VPNLOUT	O	109	Panel on/off switch out (Max current driving 1A)
BJT_B	O	58	Embedded regulator P type BJT control pin out

n Crystal out pin out decision table

Host interface	MCU location	Crystal pin out
Parallel	Left	110 or 48
Serial	Left	110 or 48
Parallel	Right	110 or 48
Serial	Right	110 or 48

The Crystal OUT can be output from PIN48 or PIN110, and then turn off one of them.

Power on latch pins:

TMDS_TST(PIN 5) – Host interface selection (1 for parallel, 0 for serial)

PLL_TEST1(PIN 3) – RTD Host Interface location selection (1 for 112-115,118/119, 0 for 52-57)

PLL_TEST2 (PIN 4) –Crystal in frequency adoption (1 for 1X of crystal in, 0 for 2X of crystal in M2PLL)

2. Chip Data Path Block Diagram

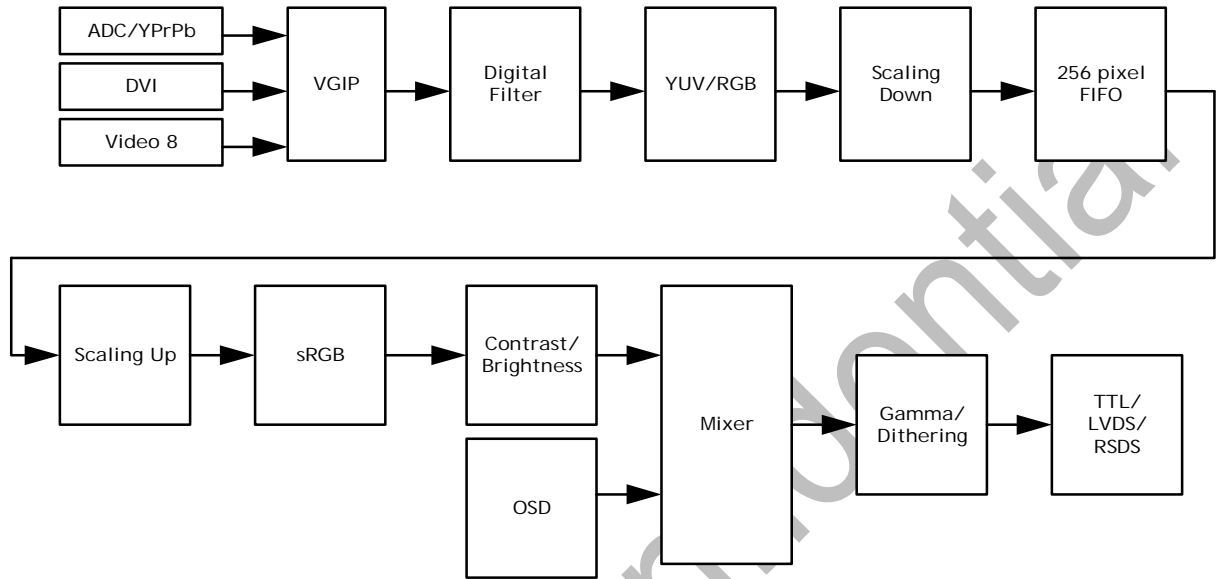

3. Architecture

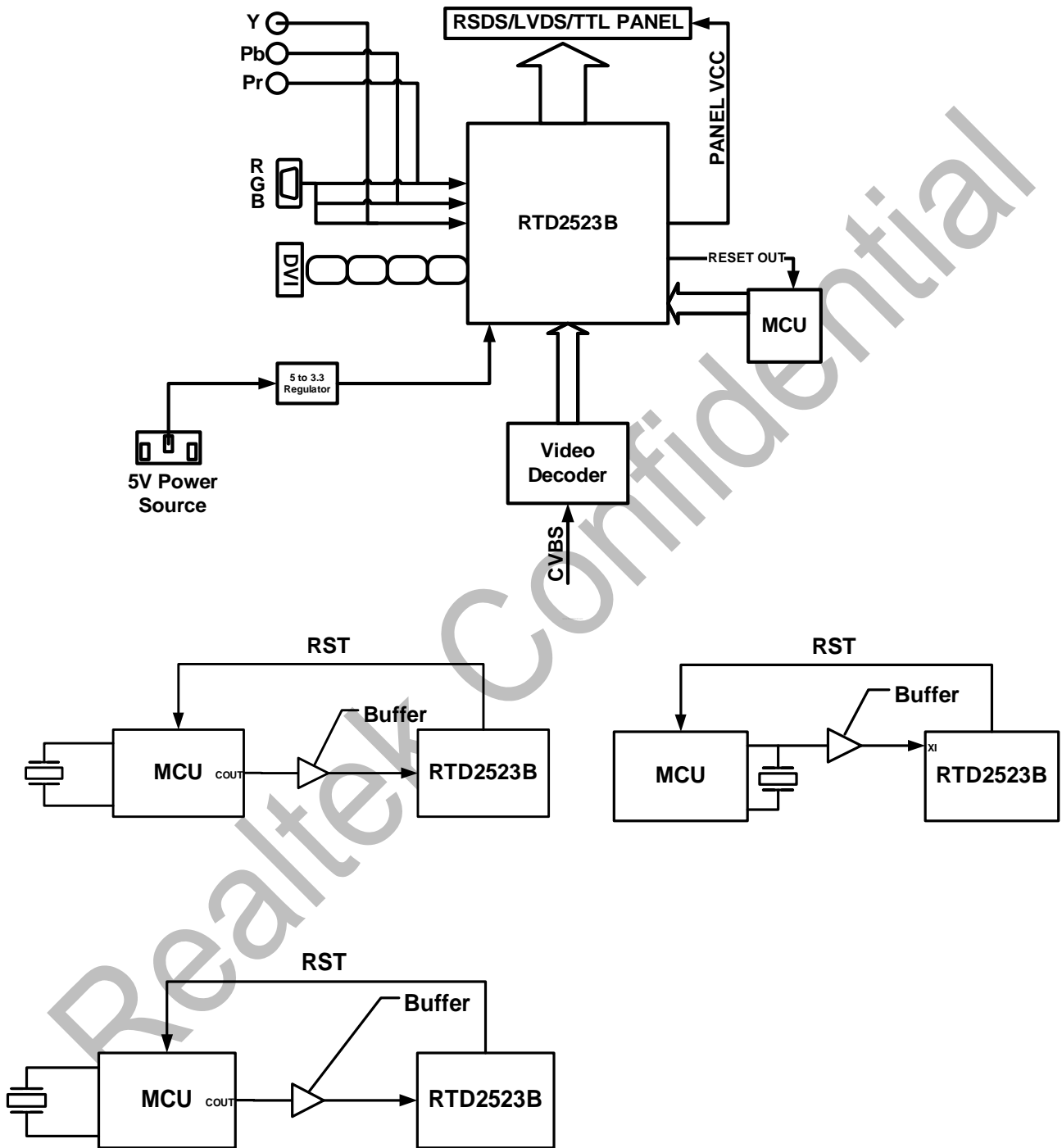

Figure 1

4. Functional Description

4.1 Input

Digital Input (ITU 656)

RTD is designed to connect the interface of digital signal from video decoder. Input data is latched within a capture window defined in registers. The timing scheme designed for input devices are showed in the following diagram.

There are not H sync 、 V sync signals provided by the video decoder with ITU BT.656, these synchronal signals have to be generated by decoding the EAV & SAV timing reference signals.

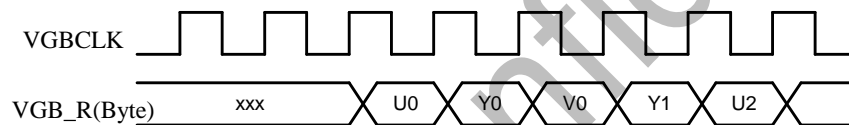

Figure 2 Input YUV 4:2:2(8-bits) Timing

Only 254 of possible 256 8-bit words may be used to express a signal value, 0 and 255 are reserved for data identification purposes. Video 8 data stream is as below:

Blanking period			Timing reference code			720 pixels YUV 422 DATA											Timing reference code			Blanking period		
...	80	10	FF	00	00	SAV	Cb0	Y0	Cr0	Y1	Cb2	Y2	...	Cr718	Y719	FF	00	00	EAV	80	10	...

Cbn: U(B-Y) colour difference component

Yn : luminance component

Crn: V(R-Y) colour difference component

SAV/EAV format

Bit 7	Bit 6(F)	Bit 5(V)	Bit 4(H)	Bit 3(P3)	Bit 2(P2)	Bit 1(P1)	Bit 0(P0)

1	Field bit 1 st field F=0 2 nd field F=1	Vertical blanking bit V=1 Active video V=0	H=0 in SAV H=1 in EAV	Protection bits
---	---	---	--------------------------	-----------------

Hardware can recognize the occurrence of EAV & SAV by detecting the 0xff , 0x00 , 0x00 data sequence, and then generate the Hsync 、Vsync 、Field signals internally by decoding the fourth word of the timing reference signal(EAV 、SAV). F & V change state synchronously with the EAV(End of active video) reference code at the beginning of the digital line.

Bits P0, P1, P2, P3, have states dependent on the states of the bits F, V and H as shown below. At the receiver this permits one-bit errors to be corrected and two-bits errors to be detected.

Protection bits

F	V	H	P3	P2	P1	P0
0	0	0	0	0	0	0
0	0	1	1	1	0	1
0	1	0	1	0	1	1
0	1	1	0	1	1	0
1	0	0	0	1	1	1
1	0	1	1	0	1	0
1	1	0	1	1	0	0
1	1	1	0	0	0	1

Error correction

$$A = P1 \text{ xor } F \text{ xor } V$$

$$B = P2 \text{ xor } F \text{ xor } H$$

$$C = P3 \text{ xor } V \text{ xor } H$$

$$D = F \text{ xor } V \text{ xor } H \text{ xor } P3 \text{ xor } P2 \text{ xor } P1 \text{ xor } P0$$

$$F' = F \text{ xor } (D \cdot A \cdot B \cdot C\#)$$

$$V' = V \text{ xor } (D \cdot A \cdot B\# \cdot C)$$

$$H' = H \text{ xor } (D \cdot A\# \cdot B \cdot C)$$

SAV/EAV one-bit error occurs when $D \cdot (A + B + C)$

SAV/EAV two-bit error occurs when $D\# \cdot (A + B + C)$

Analog Input

RTD 2523B integrates three ADC's (analog-to-digital converters), one for each color (red, green, and blue). The sync-processor can deal with Separate-Sync, Composite-Sync, and Sync-On-Green. And the PLL can generate very low jitter clock from HS to sample the analog signal to digital data. Input data is latched within a capture window defined in registers refer to VS and HS leading edge.

RTD 2523B has a YPbPr input, we can connect DVD or some devices that has YPbPr input,

TMDS Input (Optional)

RTD 2523B integrates high-speed single link receiver function. It can operate up to 135 M at 25 meters cable. RTD 2523B integrates an equalizer to enhance the cable loss weakness in long cable application and the advanced tracking algorithm to have better performance in DVI RX and with good capability of popular DVI graphic cards in the market.

Realtek Confidential

Input Capture Window

Inside RTD, there are four registers IPH_ACT_STA, IPH_ACT_WID, IPV_ACT_STA & IPV_ACT_LEN to define input capture window for the selected input video on either A or B input port while programmed analog input mode. The horizontal sync (IHS) & vertical sync (IVS) signals are used from the selected port to determine the capture window region.

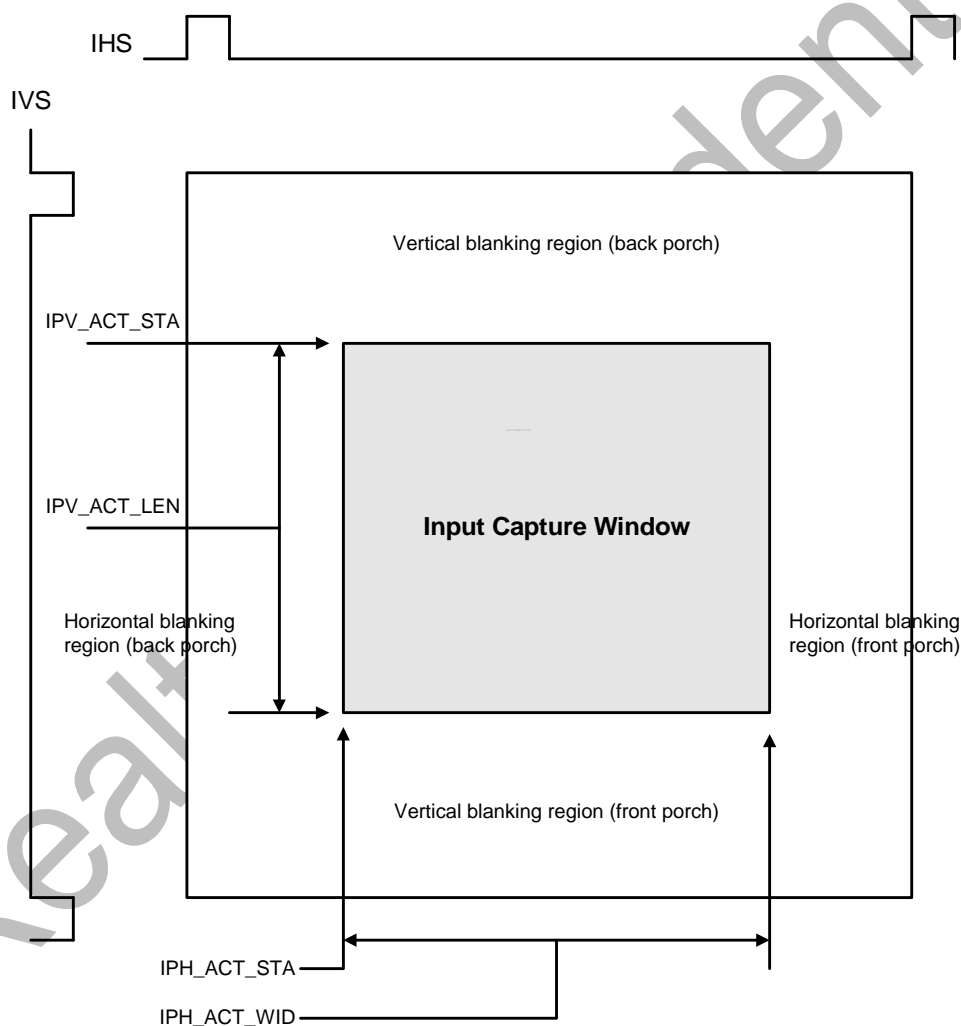

Figure 3 Input Capture Window

4.2 Output Timing

Display Output Timing

The display output port sends single/double pixel data transfer and synchronized display timing to an external device. The display port also support display panel with 6-bit per color, turn on the dithering function to enhance color depth.

In single pixel output mode, single pixel data (24-bit RGB) is transferred to display port A on each active edge of DCLK, the rate of DCLK is also equal to display pixel clock. The sync & enable signals are also sent to display port on each active edge of DCLK.

In double pixel output mode, double pixel data (48-bit RGB) is transferred to display port A & B on each active edge of DCLK and the rate of DCLK is equal to half display pixel clock at this moment. The sync & enable signals are also sent to display port on each active edge of DCLK.

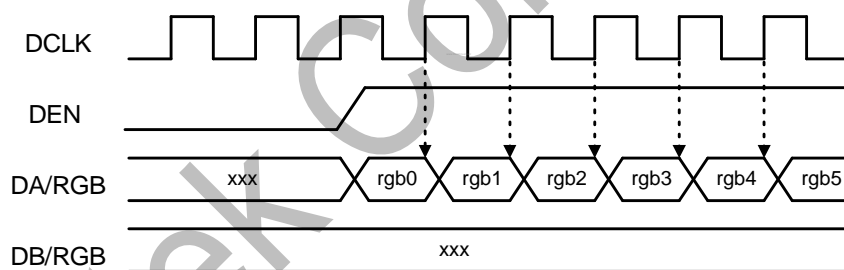

Figure 4 TTL Single Pixel Mode Display Data Timing

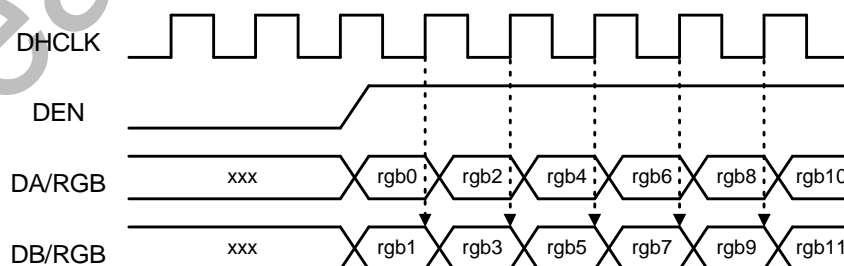

Figure 5 TTL Double Pixel Mode Display Data Timing

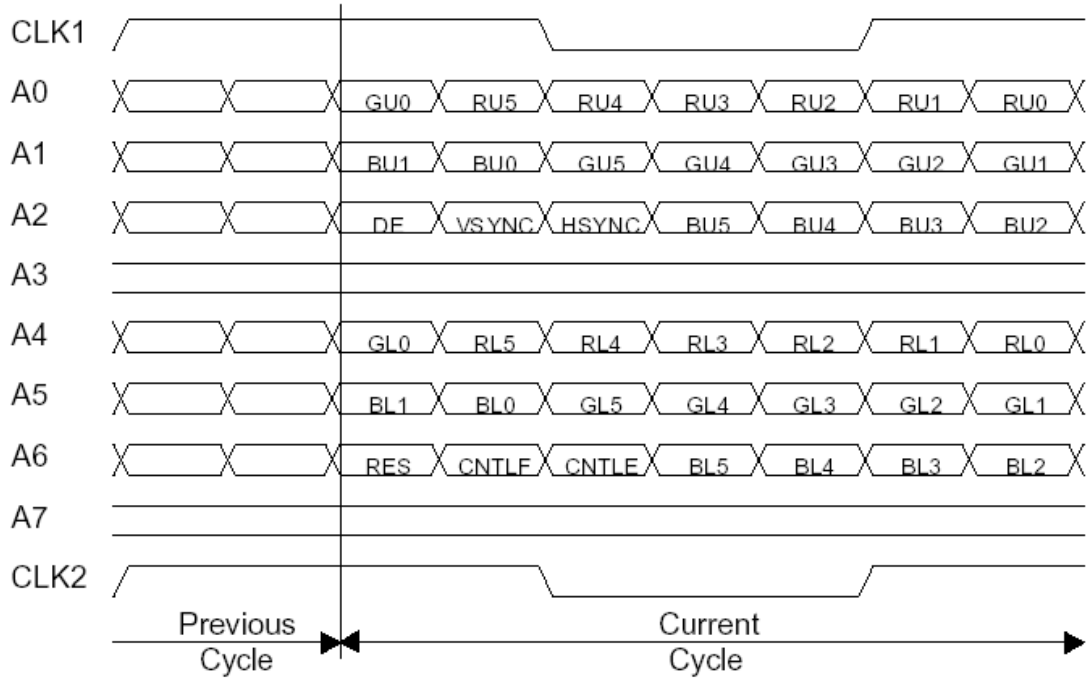

Figure 6 LVDS 18bit Display Timing

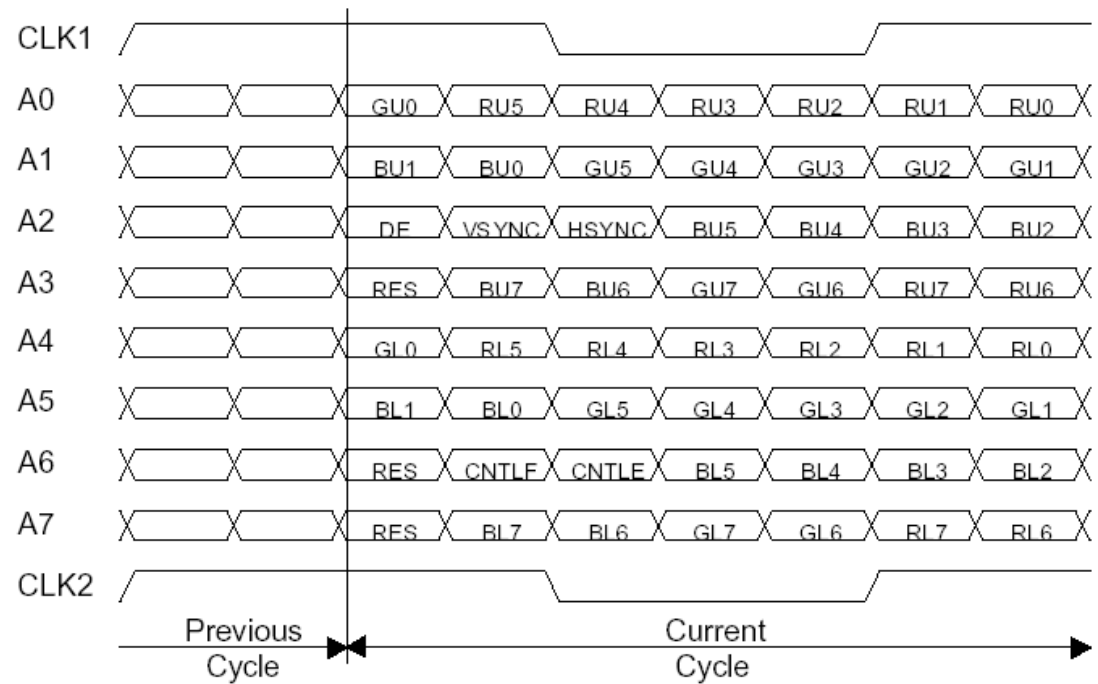

Figure 7 LVDS 24 bit Display Timing

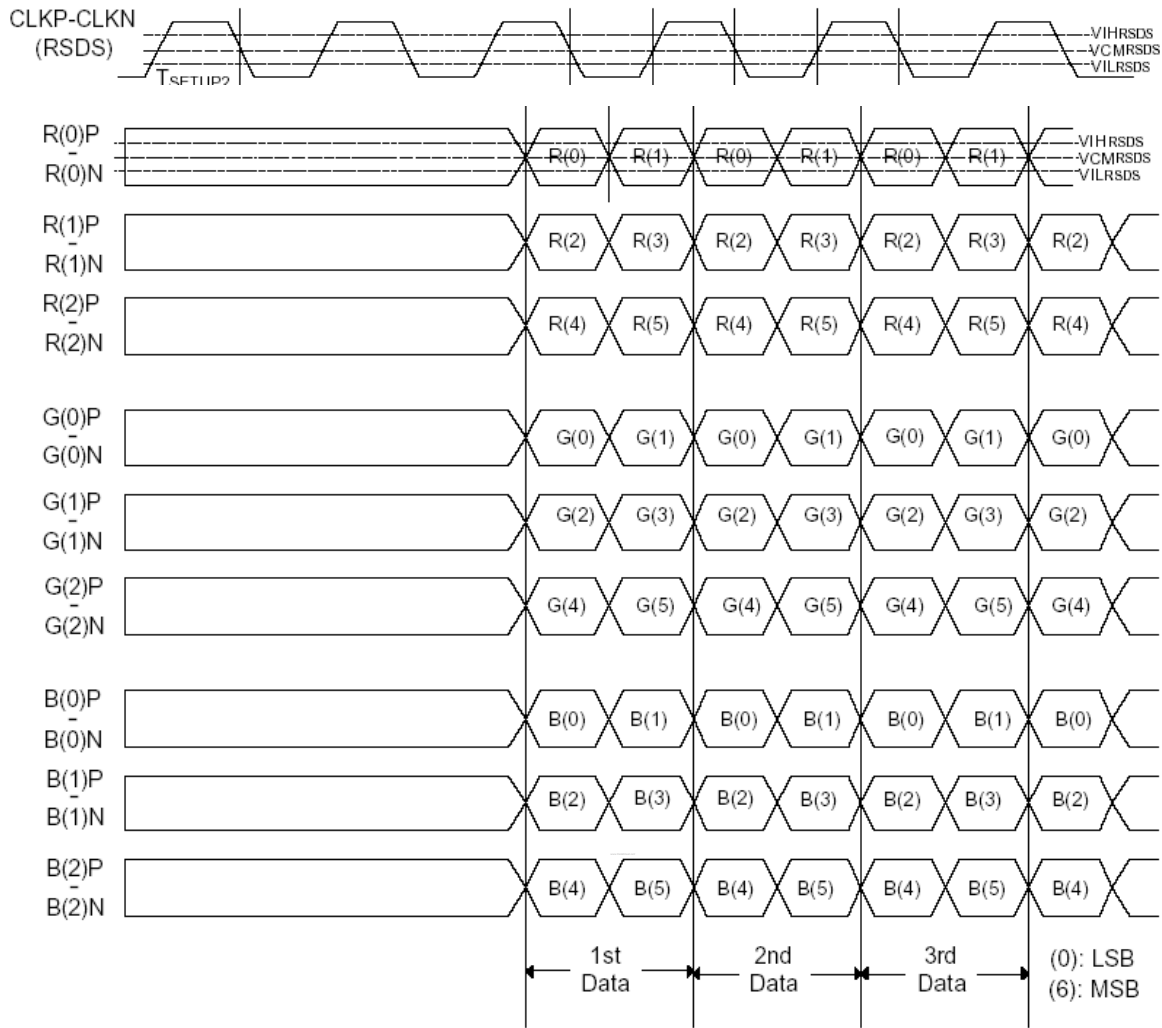

Figure 8 RSDS TYPE3 Display Timing

Realtek

Display Active Window

These registers to define the **display active window** shown below in application of frame sync mode. Refer to the register description for detail.

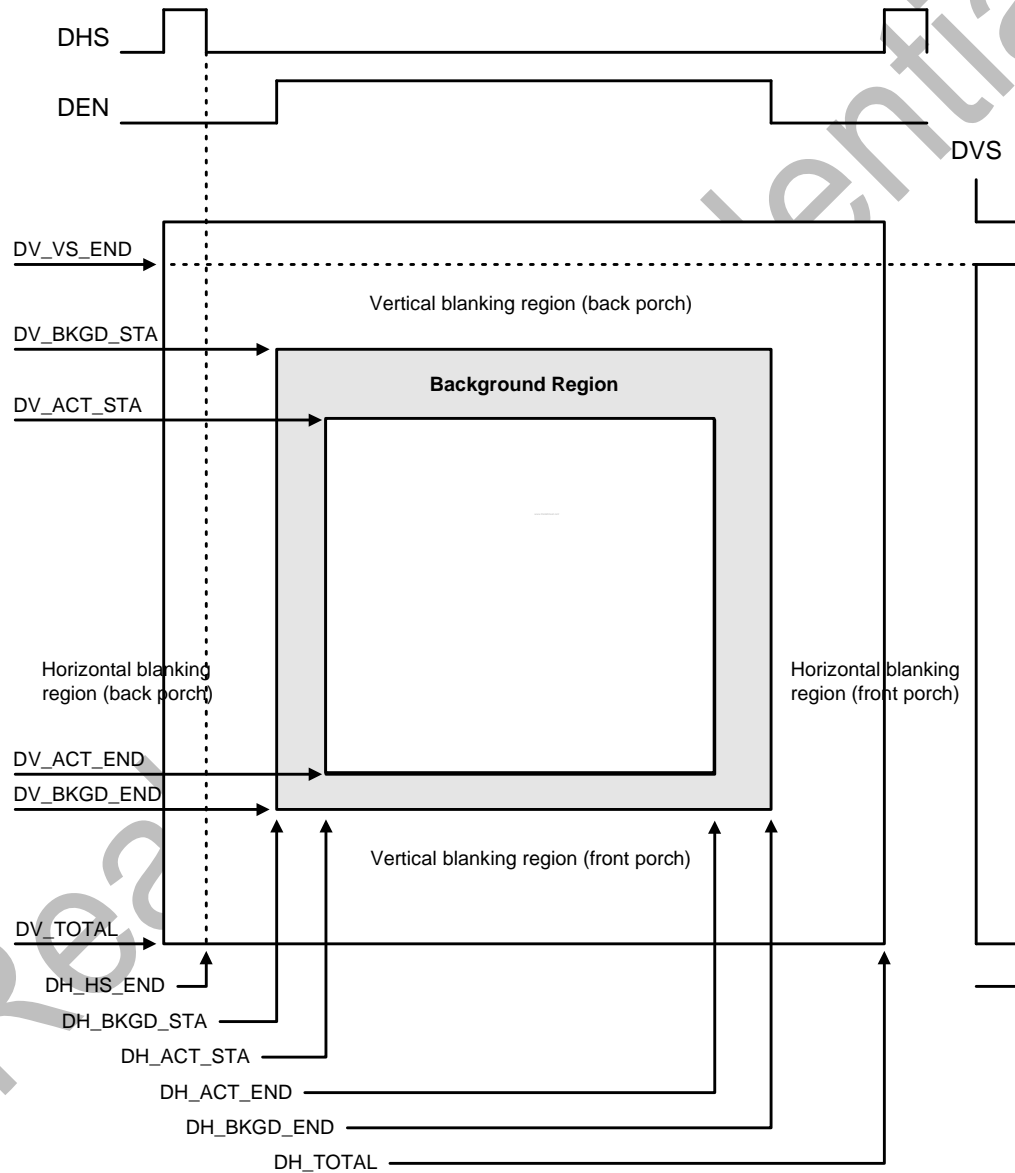

Figure 9 Display Active Window Diagram

4.3 Color Processing

Digital color R & G & B independent channel sRGB, contrast, brightness, gamma, dithering controls are built in RTD. sRGB compliance function is provided with 9 multipliers. The contrast control is performed a multiply value from 0 to 2 for each R/G/B channel. The brightness control is used to set an offset value from -512 to +511 also for each R/G/B channel. Also RTD2523B provided 10 bit gamma and a high performance dithering function.

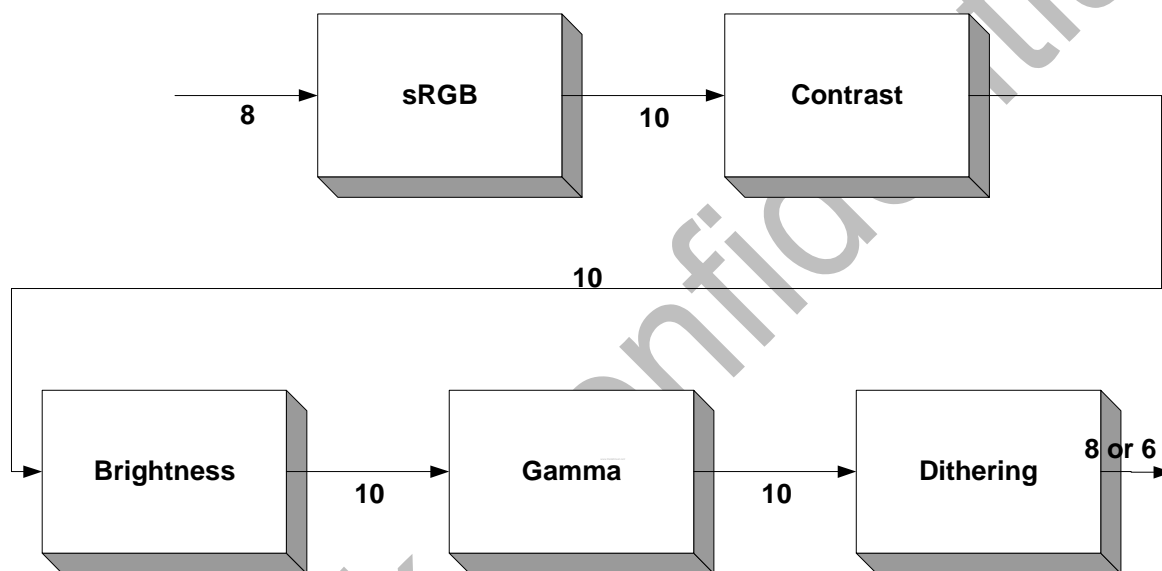

Figure 10 Color Processing Block Diagram

4.4 OSD & Color LUT

Build-In OSD

The detailed function-description of build-in OSD, please refer to the application note for RTD embedded OSD.

Color LUT & Overlay Port

The following diagram presents the data flow among the gamma correction, dithering, overlay MUX, OSD LUT and output format conversion blocks.

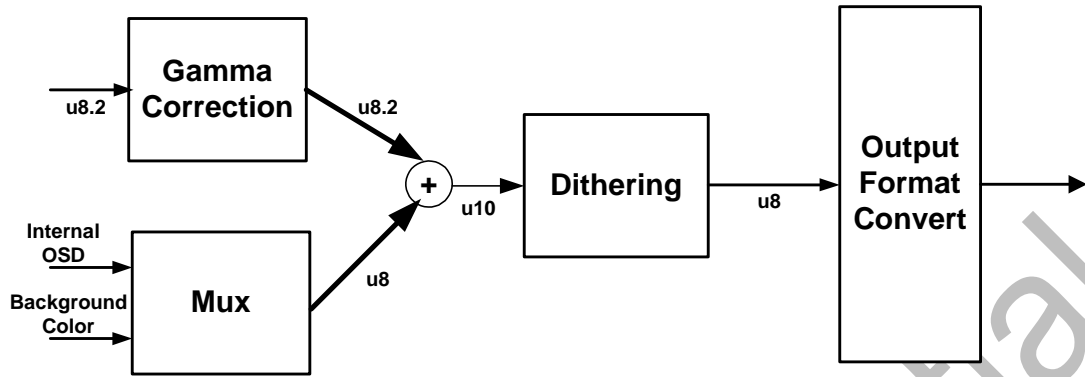

Figure 11 OSD color look-up table data path diagram

Realtek Confidential

4.5 Auto-Adjustment

There are two main independent auto-adjustment functions supported by RTD, including auto-position & auto-tracking. The operation procedure is as following;

Auto-Position

1. Define the RGB color noise margin: When the value of color channel R or G or B is greater than these noise margins, a valid pixel is found.
2. Define the threshold-pixel for vertical boundary search
3. Define the boundary window of searching for horizontal boundary search.
4. Start auto-function.
5. The result can be read from register.

Auto-Tracking

1. Setting the control-registers for the function (auto-phase, auto-balance) according to the Control-Table.
2. Define the Threshold
3. Define the boundary window of searching for tracking window.
4. Start auto-function.
5. The result can be read from register

4.6 PLL System

Inside the RTD, there are four PLL systems for display clock and ADC sample clock (PLL1, PLL2, M2PLL, DPLL).

DCLK PLL

DPLL frequency = $F_{IN} * DPM / DPN * Divider$.

F_{IN} is input crystal frequency. DPM and DPN is in DPLL M and DPLL N. Divider is in DPLL N, and it divide PLL frequency by 1, 2, 4 or 8.

According to parameter DPN, you must set LPF Mode in DPLL WD. If LPF Mode is 1, the charge pump current, Ich, must be $DPM/17.6$, while Ich must be $DPM/1.67$ if LPF Mode is 0. The charge pump current Ich is in DPLL CRNT.

Spread-Spectrum function is also build in DCLK to reduce EMI. You can control the SSP_I, SSP_W, and FMDIV to fine-tune the EMI.

M2PLL

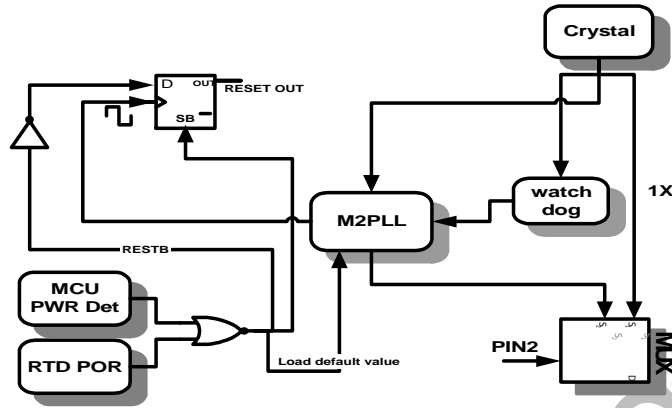

Figure 12 M2PLL System Block Diagram

M2PLL is a PLL used to double the input Xtal clock, once if you use a 12M Xtal, tie PIN2 low, otherwise, tie it high, by this procedure; you can use only one Xtal to share between MCU and Scalar.

ADC Pixel Sampling PLL

The input pixel sampling PLL of RTD2523B compose of PLL1 and PLL2 and DDS, the hybrid PLL system inherently has a process-independent advantages comparing with pure analog PLL, DDS synthesizer is in charge of the phase-frequency control, PLL1 provided a high frequency to get a larger bandwidth letting the system fast locking, PLL2 finally synthesize the desired pixel sampling clock. The block diagram shown below describes our high-performance tracking system.

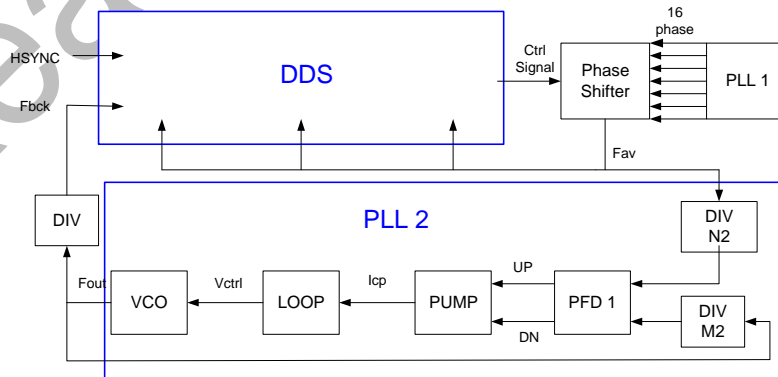

Figure 13 APLL System Block Diagram

4.7 Host Interface

Parallel/Serial Port Determination:

After RESET end, the status of pin 5 (TMDS_TST) can be sensed to determine the interface mode: high for parallel port, low, low for serial port.

Host Interface Location Determination:

After the falling edge of RESET signal, the status of pin 3 can be sensed to determine the host interface location: high for 112-115,118,119, and low for 52-57

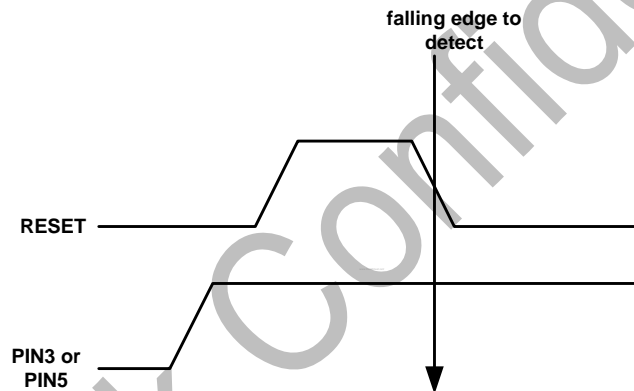

Figure 14 Serial/Parallel port and host interface location selection

Double Data Rate Serial/Parallel Interface:

Any transaction should start from asserted the SCSB low and stop after the SCSB goes high.

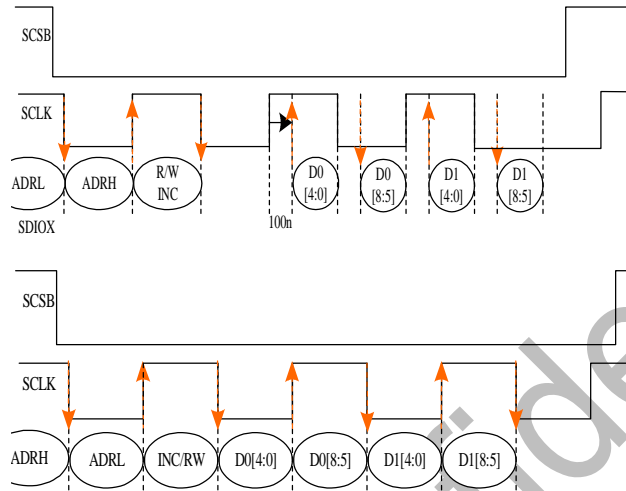
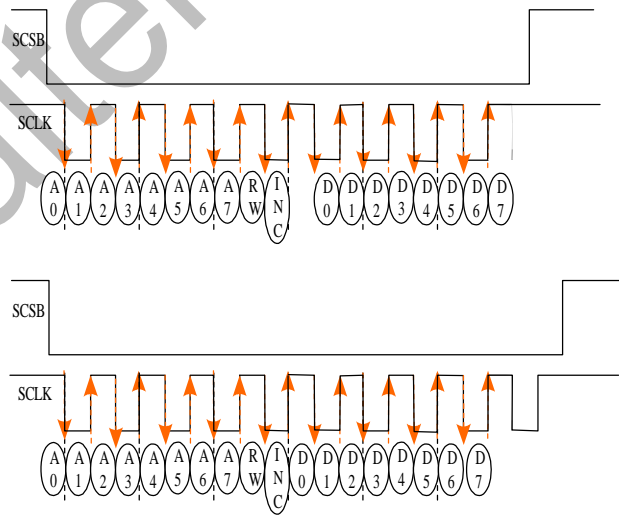

Figure 15 Parallel Port Read (Upper)/Write (Below) with Dual edge data latch

SDIO0	ADRL [A0]	ADRH[A4]	R/W	D0[0]	D0[4]	D1[0]	D1[4]
SDIO1	ADRL [A1]	ADRH[A5]	INC	D0[1]	D0[5]	D1[1]	D1[5]
SDIO2	ADRL [A2]	ADRH[A6]	X	D0[2]	D0[6]	D1[2]	D1[6]
SDIO3	ADRL [A3]	ADRH[A7]	X	D0[3]	D0[7]	D1[3]	D1[7]

Parallel port data alignment



A0	A1	A2	A3	A4	A5	A6	A7	R/W	INC	D0	D1	D2	D3	D4	D5	D6	D7
----	----	----	----	----	----	----	----	-----	-----	----	----	----	----	----	----	----	----

Serial Port Read (Upper)/Write (Below) with Dual edge data latch, and Serial port data alignment

4.8 Reset Output

We have the RESET_OUT function, and also reserve the RESET_IN function. By the bounding of internal pins we can select two kinds of reset function. First of all is only reset-out, we can output the reset signal to MCU, and the MCU can reset the RTD by firmware. The second is RTD output reset and also reset itself. Notice that the reset output is positive polarity, besides, the reset output is open-drain pin, please don't forget to attach a **pull-up resistor (10K)**.

The reset function for 3.3V operating voltage detection is determined by **33VRST_REF** voltage, No matter 5V or 3.3V MCU is been used, divider the input voltage on 33VRST_REF to 2.2V for internal power sensing circuit detecting, the divider resistor should be 10K level avoiding current leakage.

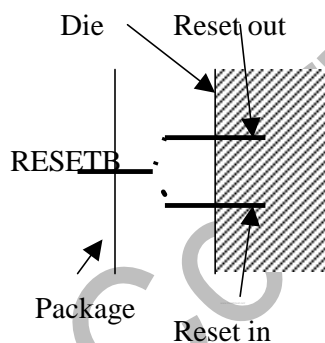

Figure 16 RESET function

4.9 The Programmable Schmitt Trigger of HSYNC

To get better waveform of the input HSYNC, we have a programmable Schmitt Trigger circuit. For different HSYNC amplitude and polarity, we can select different setting of the threshold voltage.

The V_t^+ and the V_t^- can be selected by register CR97

We can select the old mode or the new mode. When using the new mode we can directly determine the positive threshold voltage (1.6V, 1.7V... 2.1V), and we can choose the hysteresis from the V_t^+ to determine the V_t^- (0.2V, 0.75V, 1.1V, 1.5V). We also can finely tune the voltage by minus 0.1V. For application, we can select different threshold voltage by the polarity of the HSYNC. The control register is CR97

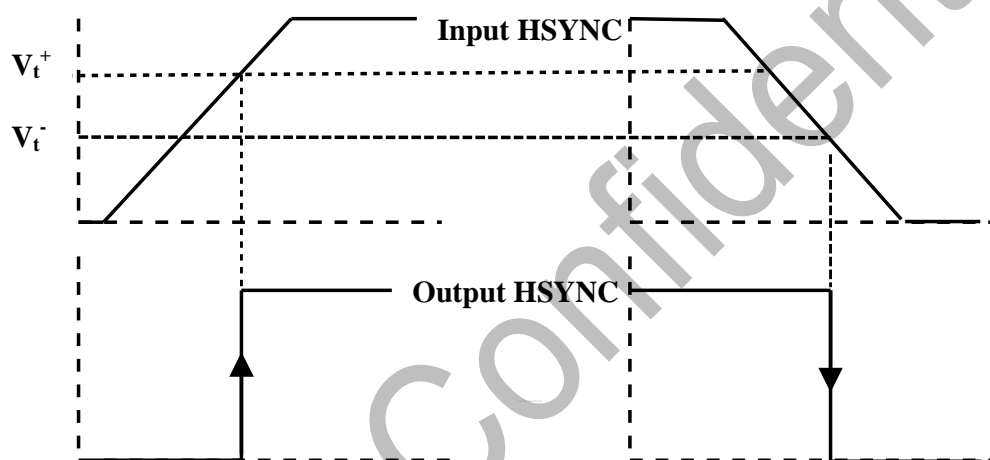

Figure 17 the Schmitt Trigger Behavior Diagram

4.10 Crystal Frequency Output

RTD can output crystal frequency or 1/2 or 1/4 crystal frequency to external MCU to save a crystal device. Once power state is on and reset is finished, we can set crystal frequency by firmware and output to pin 48 and pin 110 simultaneously, and then can turn off them in Pin Share Part. Pin 48 and PIN 110 is configurable, detail setting is listed in [Pin Share](#) part

This page is left for blank

Realtek Confidential

5. Register description

Global event flag

Reading unimplemented registers will return 0.

Address: 00 ID_REG **Default: 91**

Bit	Mode	Function
7:0	R	MSB 4 bits: 1001 product code LSB 4 bits: 0001 rev. code

Address: 01 HOSTCTRL **Default: 02**

Bit	Mode	Function
7:3	--	Reserved to 0
2	R/W	Power Down Mode Enable 0: Normal (Default) 1: Enable power down mode Turn off ADC R/G/B/Banggap/DPLL/LVDS/PLL1/PLL2/SOG/SYNC PROC/TMDS
1	R/W	Power Saving Mode Enable 0: Normal 1: Enable power saving mode (Default) Turn off ADC R/G/B/DPLL/LVDS/PLL1/PLL2
0	R/W	Software Reset Whole Chip (Low pulse at least 8ms) 0: Normal (Default) 1: Reset (All registers are reset to default except HOST_CTRL& M2PLL &COUT Freq(TCON00[3:2]), the only difference with Hardware-Reset is power on latch won't not work)

Address: 02 STATUS0 (Status0 Register) **Default: 00h**

Bit	Mode	Function
7	R	ADC_PLL Non-Lock: (PFD counts over 32 Fav clocks) If the ADC_PLL non-lock occurs, this bit is set to "1".
6	R	Input VSYNC Error If the input vertical sync occurs within the programmed active period, this bit is set to "1".
5	R	Input HSYNC Error If the input horizontal sync occurs within the programmed active period, this bit is set to "1".
4	R	Input ODD Toggle Occur (For internal field odd toggle, refer to CR0F[5]) If the ODD signal (From SAV/EAV) toggle occurs, this bit is set to "1".
3	R	Video-8 Input Vertical/Horizontal Sync Occurs

		If the YUV input V or H sync edge occurs, this bit is set to “1”.
2	R	ADC Input Vertical/Horizontal Sync Occurs Input V or H sync edge occurs; this bit is set to “1”. This mechanism refers to current selected ADC,(i.e.: we can choose from ADC0/ADC1)
1	R	Input Overflow Status (Frame Sync Mode) If an overflow in the input data capture buffer occurs, this bit is set to “1”. ²
0	R	Line Buffer Underflow status (Frame Sync Mode) If an underflow in the line-buffer occurs, this bit is set to “1”.

Write to clear status.

Address: 03 STATUS1 (Status1 Register) Default: 00h

Bit	Mode	Function
7	R	Line Buffer Overflow Status³ 1: Line Buffer overflow has occurred since the last status cleared
6	R	Line Buffer Underflow Status 1: Line Buffer underflow has occurred since the last status cleared
5	R	DENA Stop Event Status 1: If the DENA stop event occurred since the last status cleared
4	R	DENA Start Event Status 1: If the DENA start event occurred since the last status cleared
3	R	DVS Start Event Status 1: If the DVS start event occurred since the last status cleared
2	R	IENA Stop Event Status 1: If the IENA stop event occurred since the last status cleared
1	R	IENA Start Event Status 1: If the IENA start event occurred since the last status cleared
0	R	IVS Start Event Status 1: If the IVS start event occurred since the last status cleared

Write to clear status.

Address: 04 IRQ_CTRL0 (IRQ Control Register 0) Default: 00h

Bit	Mode	Function
7	R/W	Internal IRQ Enable: (Global) 0: Disable these interrupt. 1: Enable these interrupt. The IRQ event of CRF9 & CR04 will be logically “OR” together.
6	R/W	IRQ (ADC_PLL Non-Lock)

² Only the first event of input overflow/underflow will be recorded at the same time.

³ Both input overflow/underflow status will be recorded whenever it happens.

		0: Disable the ADC_PLL non-lock error event as an interrupt source 1: Enable the ADC_PLL non-lock error event as an interrupt source
5	R/W	IRQ (Input VSYNC/HSYNC Error) (DEN across Vsync or Hsync) 0: Disable the Input VSYNC/HSYNC error event as an interrupt source 1: Enable the Input VSYNC/HSYNC error event as an interrupt source
4	R/W	IRQ (Input ODD Toggle Occur) (EAV/SAV from Video8) 0: Disable the Input ODD toggle event as an interrupt source 1: Enable the Input ODD toggle event as an interrupt source
3	R/W	IRQ (Video-8 Input Hsync/Vertical Sync Occurs) 0: Disable the Video8 Input Hsync or Vsync event as an interrupt source 1: Enable the Video8 Input Hsync or Vsync event as an interrupt source
2	R/W	IRQ (ADC Input Hsync/Vertical Sync Occurs) 0: Disable the ADC Input Hsync or Vsync event as an interrupt source 1: Enable the ADC Input Hsync or Vsync event as an interrupt source
1	R/W	IRQ (Line Buffer Underflow/Overflow Status) 0: Disable the Line Buffer underflow/overflow event as an interrupt source 1: Enable the Line Buffer underflow/overflow event as an interrupt source
0	--	Reserved to 0

Input Video Capture

Capture Format

Address: 05 **VGIP_CTRL (Video Graphic Input Control Register)** **Default: 00h**

Bit	Mode	Function														
7	R/W	8 bit Random Generator 0: Disable(Default) 1: Enable														
6	R/W	Input Test Mode: 0: Disable (Default) 1: Video8 input will go through RGB channel, AVS=>IVS, AHS=>IHS, VCLK=>ICLK														
5	R/W	VGIP Double Buffer Ready 0: Not Ready to Apply 1: Ready to Apply When the list table of CR05 [4] is set, then enable CR05 [5], finally, hardware will auto load these value into RTD2523B as the trigger event happens and clear CR05 [5] to 0.														
4	R/W	VGIP Double Buffer Mode Enable(Each register describe below has its own double buffer) 0: Disable (Original- Write instantly by MCU write cycles) 1: Enable (Double Buffer Function Write Mode) <table border="1" data-bbox="418 1234 1058 1871"> <thead> <tr> <th>Register</th> <th>Trigger Event</th> </tr> </thead> <tbody> <tr> <td>IPH_ACT_STA(CR09,CR0A)</td> <td>IDEN STOP (Falling edge of IDEN)</td> </tr> <tr> <td>IPV_ACT_STA (CR09,CR0A) IV_DV_LINES (CR40)</td> <td>IDEN STOP (Falling edge of IDEN)</td> </tr> <tr> <td>IHS Delay(for capture) (CR12, CR13[0])</td> <td>IDEN STOP (Falling edge of IDEN)</td> </tr> <tr> <td>PLLPHASE(CRAB,CRAC) Add 1-clk Delay to IHS Delay (CR07[4])</td> <td>IDEN STOP (Falling edge of IDEN)</td> </tr> <tr> <td>HSYNC Synchronize Edge (CR07[3])</td> <td></td> </tr> <tr> <td>IVS_DELAY(for capture) (CR[11],CR13[1])</td> <td>IDEN STOP (Falling edge of IDEN)</td> </tr> </tbody> </table>	Register	Trigger Event	IPH_ACT_STA(CR09,CR0A)	IDEN STOP (Falling edge of IDEN)	IPV_ACT_STA (CR09,CR0A) IV_DV_LINES (CR40)	IDEN STOP (Falling edge of IDEN)	IHS Delay(for capture) (CR12, CR13[0])	IDEN STOP (Falling edge of IDEN)	PLLPHASE(CRAB,CRAC) Add 1-clk Delay to IHS Delay (CR07[4])	IDEN STOP (Falling edge of IDEN)	HSYNC Synchronize Edge (CR07[3])		IVS_DELAY(for capture) (CR[11],CR13[1])	IDEN STOP (Falling edge of IDEN)
Register	Trigger Event															
IPH_ACT_STA(CR09,CR0A)	IDEN STOP (Falling edge of IDEN)															
IPV_ACT_STA (CR09,CR0A) IV_DV_LINES (CR40)	IDEN STOP (Falling edge of IDEN)															
IHS Delay(for capture) (CR12, CR13[0])	IDEN STOP (Falling edge of IDEN)															
PLLPHASE(CRAB,CRAC) Add 1-clk Delay to IHS Delay (CR07[4])	IDEN STOP (Falling edge of IDEN)															
HSYNC Synchronize Edge (CR07[3])																
IVS_DELAY(for capture) (CR[11],CR13[1])	IDEN STOP (Falling edge of IDEN)															
3:2	R/W	Input Pixel Format														

		00: Embedded ADC (ADC_HS)(Default) 01: Embedded TMDS 10: Video 8 11: Reserved
1	R/W	Input Data Capture mode 0: From analog input (input captured by 'Input Capture Window') (Default) 1: From digital input (captured start by 'enable signal', but sill stored in 'capture window size')
0	R/W	Input Data Run Enable 0: No data is transferred (Default) 1: Sampling input pixels

Address: 06 **VGIP_SIGINV (Input Control Signal Inverted Register)** **Default: 00h**

Bit	Mode	Function
7	R/W	Safe Mode 0: Normal (Default) 1: Safe Mode Enable, mask 1 frame IVS of every 2 frame IVS, slow down input frame rate.
6	R/W	IVS Sync with IHS Control (avoid VS bouncing) 0: Enable (Default) 1: Disable
5	R/W	HS Signal Inverted for Field Detection 0: Negative Edge (Default) 1: Positive Edge
4	R/W	Input Video ODD signal invert enable (from EAV) 0: Not inverted (ODD = positive polarity) (Default) 1: Inverted (ODD = negative polarity)
3	R/W	Input VS Signal Polarity Inverted 0: Not inverted (VS = positive polarity) (Default) 1: Inverted (VS = negative polarity)
2	R/W	Input HS Signal Polarity Inverted 0: Not inverted (HS = positive polarity) (Default) 1: Inverted (HS = negative polarity)
1	R/W	Input ENA Signal Polarity Inverted 0: Not inverted (input high active) (Default) 1: Inverted (while input low active)
0	R/W	Input Clock Polarity 0: Rising edge latched (Default) 1: Falling edge latched

Address: 07 VGIP_DELAY_CTRL Default: 00h

Bit	Mode	Function
7	R	6-Iclk-delay HS level latched by VS rising edge
6	R	HS level latched by VS rising edge
5	R	HS level latched by 6-Iclk-delay VS rising edge
4	R/W	Add one clock delay to IHS delay 0: Disable (Default) 1: Enable
3	R/W	HSYNC Synchronize Edge 0: HSYNC is synchronized by the positive edge of the input clock 1: HSYNC is synchronized by the negative edge of the input clock (HSYNC source is selected by CR48[0] and then synchronized)
2	R/W	VSYNC Synchronize Edge 0: latch VS by the negative edge of input HSYNC(Default) 1: latch VS by the positive edge of input HSYNC
1:0	R/W	Input Clock Delay Control: 00: Normal (Default) 01: 1ns delay 10: 2ns delay 11: 3ns delay

Address: 08 VGIP_ODD_CTRL (Video Graphic Input ODD Control Register) Default: 00h

Bit	Mode	Function
7	R/W	ODD invert for ODD-Controlled-IVS_delay. 0: Not Invert (Default) 1: Invert
6	R/W	ODD-Controlled-IVS delay one line Enable 0: Disable (Default) 1: Enable For both Auto and Capture
5	R/W	Safe Mode ODD inversion 0: Not inverted (Default) 1: Inverted
4	R/W	Force ODD toggle enable (Without ODD/EVEN toggle select in Safe Mode) 0: Disable (Default) 1: Enable
3	R/W	Video 4:2:2->4:4:4 enable before Scale Down (Duplicate)

		0: Disable (Default) 1: Enable i.e. This bit should be always enable when in Video8 mode.
2	R/W	Decode Video8 when ADC or TMDS active 0: Disable (Default) 1: Enable
1	R/W	EAV Error Correction Enable in Video8 0: Disable 1: Enable
0	R/W	Internal ODD signal selection 0: ODD signal from EAV or YPbPr (Default) 1: Internal Field Detection ODD signal (Also support under DVI input)

Realtek Confidential

Input Frame Window (All capture window setting unit is 1)
Address: 09 IPH_ACT_STA_H (Input Horizontal Active Start) Default: 00h

Bit	Mode	Function
7	R/W	Input Test Output Enable 0: Disable (Default) 1: Test signals output to INPUT_TEST_OUT [29:0] & INPUT_CLK output to ADCLK
6:4	R/W	Select Color Output To Input_Test_Output [29:0] Pin 102-67, also set output mode to Hi-Z 000: 0, Z0TST[3:0], ADCLK, Red[7:0], Green[7:0], Blue[7:0] through VGIP 001: 0, Z0TST[3:0], ADCLK, Red[7:0], Green[7:0], Blue[7:0] After Scale Down 010: 0, Z0TST[3:0], ADCLK, IVS_DLY, IHS_DLY, IFD_ODD, IENA, VSD_DEN, VSD_ACT, Auto_hs, Auto_vs, COAST, HS_OUT, SOG_IN, CLAMP, PHASE_ERROR, SOG_IN, FAV, MSB2_signal, TMDS_DBG_OUT[7:0] 011: 0, Z0TST[3:0], ADCLK, 0, MCUWR, MCURD, MCU_ADR_INC, MIN[7:0], MADR[7:0], SDMOUT_TST[3:0], 100: 0, Z0TST[3:0], ADCLK, RAW_VS, RAW_HS, RAW_ODD, RAW_DEN, 0, 0, 0, 0, Green[7:0], Red[7:0] through VGIP 101: 0, Z0TST[3:0], ADCLK, VGIPTST_CLK, RAW_VS, RAW_HS, RAW_DEN, Red[7:0], Green[7:0], 0, 0, 0, 0 110: 0, Z0TST[3:0], ADCLK, VGIPTST_CLK, RAW_VS, RAW_HS, RAW_ODD, Blue[7:0], Green[7:0], 0, 0, 0, 0, 111: 0, Z0TST[3:0], ADCLK, VGIPTST_CLK, RAW_VS, RAW_HS, RAW_ODD, TMDS_DBG_OUT[7:0], Green[7:0], 0, 0, 0, 0
3	--	Reserved
2:0	R/W	Input Video Horizontal Active Start -- High Byte [10:8]

Address: 0A IPH_ACT_STA_L (Input Horizontal Active Start Low) Default: 00h

Bit	Mode	Function
7:0	R/W	Input Video Horizontal Active Start -- Low Byte [7:0]

! In analog mode, the number of pixel clocks from the leading edge of HS to the first pixel of the active line.

$$\text{Target} = \text{IPH_ACT_STA} (\geq 2) + 2,$$

! In digital mode, the IPH_ACT_STA is actually the same as it set.

Address: 0B IPH_ACT_WID_H (Input Horizontal Active Width High) Default: 00h

Bit	Mode	Function
7	R/W	Video 8 Port Input Latch Bus MSB to LSB Swap Control: 0: Normal (Default)

		1: Switched Video8 port MSB to LSB sequence into LSB to MSB
6	R/W	ADC input B/G Swap 0: No Swap 1: Swap
5	R/W	ADC input R/B Swap 0: No Swap 1: Swap
4	R/W	ADC input R/G Swap 0: No Swap 1: Swap
3	R/W	Double Clock Input 0: Single Clock 1: Double Clock <i>this bit should be set double clock when using video 8 input</i>
2:0	R/W	Input Video Horizontal Active Width – High Byte [10:8]

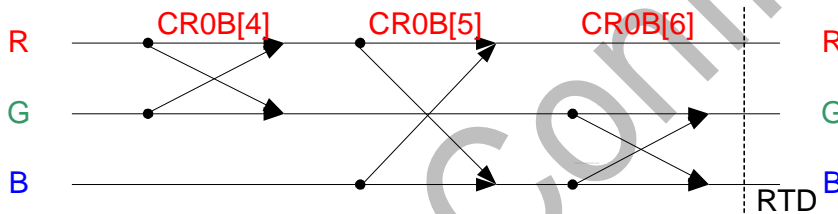

CR0B[6:4]= 000 => RGB, CR0B[6:4]= 100 => RBG, CR0B[6:4]= 001 => GRB,
CR0B[6:4]= 101 => GBR, CR0B[6:4]= 010 => BGR, CR0B[6:4]= 011 => BRG

Address: 0C **IPH_ACT_WID_L (Input Horizontal Active Width Low)**

Default: 00h

Bit	Mode	Function
7:0	R/W	Input Video Horizontal Active Width -- Low Byte [7:0]

This register defines the number of active pixel clocks to be captured.

(Horizontal Active Start + Horizontal Active Width) < 2047

Address: 0D **IPV_ACT_STA_H (Input Vertical Active Start High)**

Default: 00h

Bit	Mode	Function
7:3	--	Reserved
2:0	R/W	Input Video Vertical Active Start – High Byte [10:8]

Address: 0E **IPV_ACT_STA_L (Input Vertical Active Start Low)**

Default: 00h

Bit	Mode	Function
7:0	R/W	Input Video Vertical Active Start – Low Byte [7:0]

The numbers of lines from the leading edge of selected input video VSYNC to the first line of the active window.

The value above should be larger than 1.

Address: 0F **IPV_ACT_LEN_H (Input Vertical Active Lines)** **Default: 00h**

Bit	Mode	Function
7	R	SAV/EAV two-bit error (write to clear)
6	R	SAV/EAV one-bit error (write to clear)
5	R	Internal Field Detection ODD toggle happen (Counts by line difference) The function should be worked under no input clock
4:3	R	The number of input HS between 2 input VS. LSB bit [1:0]
2:0	R/W	Input Video Vertical Active Lines – High Byte [10:8]

Address: 10 **IPV_ACT_LEN_L (Input Vertical Active Lines)** **Default: 00h**

Bit	Mode	Function
7:0	R/W	Input Video Vertical Active Lines – Low Byte [7:0]

This register defines the number of active lines to be captured.

Address: 11 **IVS_DELAY (Internal Input-VS Delay Control Register)** **Default: 00h**

Bit	Mode	Function
7:0	R/W	Input VS delay count by Input HSYNC [7:0] It's IVS delay for capture and digital filter, not for auto function

Address: 12 **IHS_DELAY (Internal Input-HS Delay Control Register)** **Default: 00h**

Bit	Mode	Function
7:0	R/W	Input HS delay count by Input clock [7:0] It's IHS delay for capture and digital filter, not for auto function

Address: 13 **VGIP_HV_DELAY** **Default: 00h**

Bit	Mode	Function
7:6	R/W	Input HS delay count by input clock for Auto function 00: No delay 01: 32 pixels 10: 64 pixels 11: 96 pixels
5:4	R/W	Input VS delay count by input HSYNC for Auto function 00: No delay 01: 3 line 10: 7 line 11: 15 line
3:2	--	Reserved to 0
1	R/W	Input VS delay count by Input HSYNC[8]
0	R/W	Input HS delay count by Input clock[8]

FIFO Window
Address: 14 **DRL_H_BSU (Display Read High Byte Before Scaling-Up)** **Default: 00h**

Bit	Mode	Function
7	--	Reserved
6:4	R/W	Display window read width before scaling up: High Byte [10:8] (horizontal)
3	--	Reserved
2:0	R/W	Display window read length before scaling up: High Byte [10:8] (vertical)

Address: 15 **DRW_L_BSU (Display Read Width Low Byte Before Scaling-Up)** **Default: 00h**

Bit	Mode	Function
7:0	R/W	Display window read width before scaling up: Low Byte [7:0] (horizontal)

Address: 16 **DRL_L_BSU (Display Read Length Low Byte Before Scaling-Up)** **Default: 00h**

Bit	Mode	Function
7:0	R/W	Display window read length before scaling up: Low Byte [7:0] (vertical)

I The setting above should be use 2 as unit

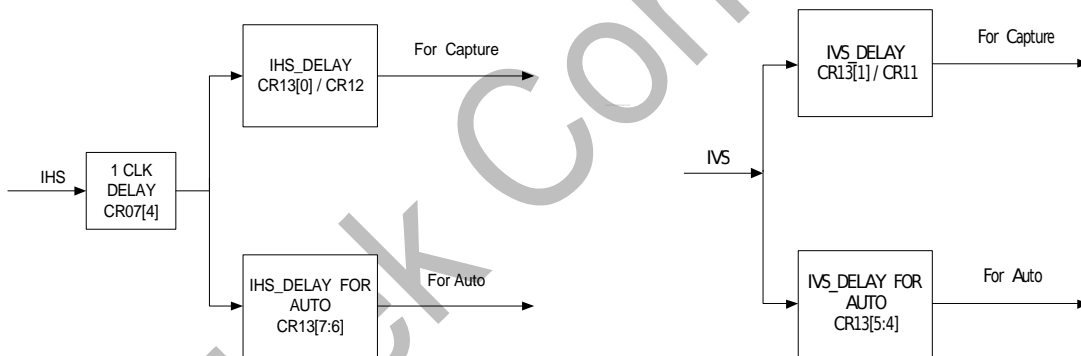

Figure 18 IHS_DELAY Path Diagram

Digital Filter
Address: 17 **DIGITAL_FILTER_CTRL** **Default: 00h**

Bit	Mode	Function
7:5	R/W	Access Port Write Enable 000: disable 001: phase access port 010: negative smear access port 011: positive smear access port 100: negative ringing access port

		101: positive ringing access port 110: mismatch access port 111: Y(B)/Pb(G)/Pr(R) channel digital filter enable
4:3	R/W	Two condition occur continuous (ringing to smear) 00: disable(hardware is off , depend on firmware) 01: only reduce ringing condition 10: only reduce smear condition 11: no adjust (hardware is on, but do nothing)
2:0	--	Reserved to 0

Address: 18 **DIGITAL_FILTER_PORT** DIGITAL_FILTER_CTRL[7:5] = 111 **Default: 00h**

Bit	Mode	Function
7	R/W	Y EN (G): function enable 0: function disable 1: function enable
6	R/W	Pb EN (B) : function enable 0: function disable 1: function enable
5	R/W	Pr EN (R) : function enable 0: function disable 1: function enable
4	R/W	Initial value: 0: raw data 1: extension
3:0	--	Reserved to 0

DIGITAL_FILTER_PORT DIGITAL_FILTER_CTRL[7:5] = 000 ~ 110 **Default: 00h**

Bit	Mode	Function
7	R/W	EN: function enable 0: function disable 1: function enable
6:4	R/W	THD_OFFSET Threshold value of phase and mismatch or offset value of smear and ringing
3:2	R/W	DIV: divider value 00: 0 01: 1 10: 2 11: 3

1:0	--	Reserved to 0
-----	----	----------------------

THD_OFFSET define:

The THD value define of phase enhance function

Bit6~4	000	001	010	011	100	101	110	111
Value	112	128	144	160	176	192	208	224

The offset value define of smear and ringing reduce function

Bit6~4	000	001	010	011	100	101	110	111
Value	no use	16	32	48	64	80	96	112

The THD value define of mismatch enhance function

Bit6~4	000	XX1
Value	1	2

Scaling Up Function

Address: 19 **SCALE_CTRL (Scale Control Register)**

Default: 00h

Bit	Mode	Function
7	R/W	Video mode compensation: 0: Disable (Default) 1: Enable
6	R/W	Internal ODD-signal inverse for video-compensation 0: No invert (Default) 1: invert
5	R	Display Line Buffer Ready 0: Busy 1: Ready
4	R/W	Enable Full Line buffer: 0: Disable (Default) 1: Enable
3	R/W	Vertical Line Duplication 0: Disable 1: Enable
2	R/W	Horizontal pixel Duplication 0: Disable 1: Enable
1	R/W	Enable the Vertical Filter Function: 0: By pass the vertical filter function block (Default)

		1: Enable the vertical filter function block
0	R/W	Enable the Horizontal Filter Function: 0: By pass the horizontal filter function block (Default) 1: Enable the horizontal filter function block

! When using H/V duplication mode, FIFO window width set original width, but FIFO length should be 2X the original height.

Address: 1A SF_ACCESS_Port **Default: 00h**

Bit	Mode	Function
7	R/W	Enable scaling-factor access port
6:5	--	Reserved to 0
4:0	R/W	Scaling factor port address

! When disable scaling factor access port, the access port pointer will reset to 0

Address: 1B-00 HOR_SCA_H (Horizontal Scale Factor High)

Bit	Mode	Function
7:4	--	Reserved
3:0	R/W	Bit [19:16] of horizontal scale factor

Address: 1B-01 HOR_SCA_M (Horizontal Scale Factor Medium)

Bit	Mode	Function
7:0	R/W	Bit [15:8] of horizontal scale factor

Address: 1B-02 HOR_SCA_L (Horizontal Scale Factor Low)

Bit	Mode	Function
7:0	R/W	Bit [7:0] of horizontal scale factor

Address: 1B-03 VER_SCA_H (Vertical Scale Factor High)

Bit	Mode	Function
7:4	--	Reserved
3:0	R/W	Bit [19:16] of vertical scale factor

Address: 1B-04 VER_SCA_M (Vertical Scale Factor Medium)

Bit	Mode	Function
7:0	R/W	Bit [15:8] of vertical scale factor

Address: 1B-05 VER_SCA_L (Vertical Scale Factor Low)

Bit	Mode	Function
7:0	R/W	Bit [7:0] of vertical scale factor

This scale-up factor includes a 20-bit fraction part to present a vertical scaled up size over the stream input. For example, for 600-line original picture scaled up to 768-line, the factor should be as follows:

$$(600/768) * 2^{20} = 0.78125 * 2^{20} = 819200 = C8000h = 0Ch, 80h, 00h.$$

Address: 1B-06 Horizontal Scale Factor Segment 1 Pixel Default: 00h

Bit	Mode	Function
7:3	--	Reserved
2:0	R/W	Bit [10:8] of Scaling Factor Segment 1 pixel

Address: 1B-07 Horizontal Scale Factor Segment 1 Pixel Default: 00h

Bit	Mode	Function
7:0	R/W	Bit [7:0] of Scaling Factor Segment 1 pixel

Address: 1B-08 Horizontal Scale Factor Segment 2 Pixel Default: 00h

Bit	Mode	Function
7:3	--	Reserved
2:0	R/W	Bit [10:8] of Scaling Factor Segment 2 pixel

Address: 1B-09 Horizontal Scale Factor Segment 2 Pixel Default: 00h

Bit	Mode	Function
7:0	R/W	Bit [7:0] of Scaling Factor Segment 2 pixel

Address: 1B-0A Horizontal Scale Factor Segment 3 Pixel Default: 00h

Bit	Mode	Function
7:3	--	Reserved
2:0	R/W	Bit [10:8] of Scaling Factor Segment 3 pixel

Address: 1B-0B Horizontal Scale Factor Segment 3 Pixel Default: 00h

Bit	Mode	Function
7:0	R/W	Bit [7:0] of Scaling Factor Segment 3 pixel

Address: 1B-0C Horizontal Scale Factor Delta 1 Default: 00h

Bit	Mode	Function
7:5	--	Reserved
4:0	R/W	Bit [12:8] of Horizontal Scale Factor delta 1

Address: 1B-0D Horizontal Scale Factor Delta 1 Default: 00h

Bit	Mode	Function
7:0	R/W	Bit [7:0] of Horizontal Scale Factor delta 1

Address: 1B-0E Horizontal Scale Factor Delta 2 Default: 00h

Bit	Mode	Function
7:5	--	Reserved
4:0	R/W	Bit [12:8] of Horizontal Scale Factor delta 2

Address: 1B-0F Horizontal Scale Factor Delta 2 Default: 00h

Bit	Mode	Function
7:0	R/W	Bit [7:0] of Horizontal Scale Factor delta 2

Address: 1B-10 **Horizontal Filter Coefficient Initial Value** **Default: C4h**

Bit	Mode	Function
7:0	R/W	Accumulate Horizontal filter coefficient initial value

Address: 1B-11 **Vertical Filter Coefficient Initial Value** **Default: C4h**

Bit	Mode	Function
7:0	R/W	Accumulate Vertical filter coefficient initial value

Address: 1C **FILTER_CTRL (Filter Control Register)** **Default: 00h**

Bit	Mode	Function
7	R/W	Enable Filter Coefficient Access 0: Disable (Default) 1: Enable
6	R/W	Select H/V User Defined Filter Coefficient Table for Access Channel 0: 1 st coefficient table (Default) 1: 2 nd coefficient table
5	R/W	Select Horizontal user defined filter coefficient table 0: 1 st Horizontal Coefficient Table (Default) 1: 2 nd Horizontal Coefficient Table
4	R/W	Select Vertical user defined filter coefficient table 0: 1st Vertical Coefficient Table (Default) 1: 2 nd Vertical Coefficient Table
3:0	--	Reserved to 0

! The User Defined Filter Coefficient Table can be modified on-line. Only the non-active coefficient-table can be modified, and then switch it to active.

Address: 1D **FILTER_PORT (User Defined Filter Access Port)** **Default: 00h**

Bit	Mode	Function
7:0	W	Access port for user defined filter coefficient table

! When enable filter coefficient accessing, the first write byte is stored into the LSB(bit[7:0]) of coefficient #1 and the second byte is into MSB (bit[8:11]). Therefore, the valid write sequence for this table is c0-LSB, c0-MSB, c1-LSB, c1-MSB, c2-LSB, c2-MSB ... c63-LSB & c63-MSB, totally 64 * 2 cycles. Since the 128 taps is symmetric, we need to fill the 64-coefficient sequence into table only.

Address: 1E **OSD_REFERENCE_DEN** **Default: 00h**

Bit	Mode	Function
7:0	R/W	Position Of Reference DEN for OSD[7:0]

Address: 1F **NEW_DV_CTRL** **Default: 00h**

Bit	Mode	Function
7	R/W	New Timing Enable

		0: Disable 1: Enable
6	R/W	Line Compensation Enable 0: Disable 1: Enable
5	R/W	Pixel Compensation Enable 0: Disable 1: Enable
4	R/W	Reserved to 0
3:0	R/W	DCLK_Delay[11:8]

Address: 20 **NEW_DV_DLY** **Default: 00h**

Bit	Mode	Function
7:0	R/W	DCLK_Delay[7:0]

When CR1F[7]=1, CR1F[3:0] & CR20 can't be 0, when compensation pixel is smaller than 1 total line, just turn on pixel compensation, otherwise users should turn on line compensation

Address: 21 Reserved

Realtek Confidential

Scaling Down Control

Address: 22 **SCALE_DOWN_CTRL (Scale Down Control Register)** **Default: 00h**

Bit	Mode	Function
7	R	Bist for FiFo ok 0: Fail 1: Ok
6	R	Bist for Line Buffer one ok 0: Fail 1: Ok
5	R	Bist for Line Buffer two ok 0: Fail 1: Ok
4	R/W	Fifo Bist Function Start (Auto clear to 0 when finish) 0: Finish 1: Start
3	R/W	Line Buffer Bist Function Start (Auto clear to 0 when finish) 0: Finish 1: Start
2	R/W	Vertical Scale-Down Compensation 0: Disable (Default) 1: Enable
1	R/W	Horizontal scale down function enable: 0: Disable scale down function (Default) 1: Enable scale down function
0	R/W	Vertical scale down function enable: 0: Disable scale down function (Default) 1: Enable scale down function

Address: 23 **H_SCALE_DOWN_H (Horizontal scale down factor register)**

Bit	Mode	Function
7:3	R/W	Horizontal Scale Down Initial Select [4:0]
2:0	R/W	Horizontal Scale Down Factor: High Byte [18:16]

! Scale Down Initial Point Select: for example, if the value is 20, we select the initial point is 40/64

Address: 24 **H_SCALE_DOWN_M (Horizontal scale down factor register)**

Bit	Mode	Function
7:0	R/W	Horizontal Scale Down Factor: Low Byte [15:8]

Address: 25 H_SCALE_DOWN_L (Horizontal scale down factor register)

Bit	Mode	Function
7:0	R/W	Horizontal Scale Down Factor: Low Byte [7:0]

- | First left side point is always latched, then the remaining points interpolates by the shrinking ratio.
- | Horizontal scaling down factor should be $(X_i / X_m) * (2^{17})$ truncate.
- | The largest scale down ratio is 1/4 (integer part 2 bits)
- | Meanwhile, X_i = horizontal input width; X_m = horizontal memory write width

Address: 26 V_SCALE_DOWN_H (Vertical scale down factor register)

Bit	Mode	Function
7:6	--	Reserved to 0
5:0	R/W	Vertical Scale Down Factor: High Byte [13:8]

Address: 27 V_SCALE_DOWN_L (Vertical scale down factor register)

Bit	Mode	Function
7:0	R/W	Vertical Scale Down Factor: Low Byte [7:0]

- | Vertical scaling down factor = $(Y_i / Y_m) * (2^{12})$ truncate.
- | The largest scale down ratio is 1/4 (integer part 2 bits)
- | Meanwhile, Y_i = vertical input width; Y_m = vertical memory write width

Realtek Confidential

Display Format

Address: 28 **VDIS_CTRL (Video Display Control Register)** **Default: 20h**

Bit	Mode	Function
7	R/W	Force Display Timing Generator Enable: (Should be set when in Free-Run mode) 0: wait for input IVS trigger 1: force enable
6	R/W	Display Data Output Inverse Enable 0: Disable (Default) 1: Enable (only when data bus clamp to 0)
5	R/W	Display Output Force to Background Color 0: Display output operates normally (Default) 1: Display output is forced to the color as selected by background color (CR69)
4	R/W	Display 18 bit RGB Mode Enable 0: All individual output pixels are full 24-bit RGB (Default) 1: All individual output pixels are truncated to 18-bit RGB
3	R/W	Frame Sync Mode Enable 0: Free running mode (Default) 1: Frame sync mode
2	R/W	Display Output Double Port Enable 0: Single port output (Default) 1: Double port output In single port mode for smart panel and <u>single RSDS</u>, you can select which port you want output, default is B port, and A port is set as TCON pin (pin 61-70 changes to 85-94, pin 73-82 changes to 97-106). When single port output is set, A port is TCON, B port is display output. When EVEN/ODD swap (CR29[6]) is set, A port is display output, B port is TCON pin.
1	R/W	Display Output Run Enable 0: DHS, DVS, DEN & DATA bus are clamped to "0" (Default) 1: Display output normal operation.
0	R/W	Display Timing Run Enable 0: Display Timing Generator is halted, Zoom Filter halted (Default) 1: Display Timing Generator and Zoom Filter enabled to run normally

Steps to disable output: First set CR28[1]=0, set CR28[6], then set CR28[0]=0 to disable output.

Address: 29 **VDISP_SIGINV (Display Control Signal Inverted)** **Default: 00h**

Bit	Mode	Function
7	R/W	DHS Output Format Select (only available in Frame Sync) 0: The first DHS after DVS is active (Default) 1: The first DHS after DVS is inactive
6	R/W	Display Data Port Even/Odd Data Swap: 0: Disable (Default) 1: Enable
5	R/W	Display Data Port Red/Blue Data Swap 0: Disable (Default) 1: Enable
4	R/W	Display Data Port MSB/LSB Data Swap 0: Disable (Default) 1: Enable
3	R/W	Skew Display Data Output 0: Non-skew data output (Default) 1: Skew data output
2	R/W	Display Vertical Sync (DVS) Output Invert Enable: 0: Display Vertical Sync output normal active high logic (Default) 1: Display Vertical Sync output inverted logic
1	R/W	Display Horizontal Sync (DHS) Output Invert Enable: 0: Display Horizontal Sync output normal active high logic (Default) 1: Display Horizontal Sync output inverted logic
0	R/W	Display Data Enable (DEN) Output Invert Enable: 0: Display Data Enable output normal active high logic (Default) 1: Display Data Enable output inverted logic

Address: 2A **DH_TOTAL_H** (Display Horizontal Total Pixels)

Bit	Mode	Function
7:4	--	Reserved to 0
3:0	R/W	Display Horizontal Total Pixel Clocks: High Byte[11:8]

Address: 2B **DH_TOTAL_L** (Display Horizontal Total Pixels)

Bit	Mode	Function
7:0	R/W	Display Horizontal Total Pixel Clocks: Low Byte[7:0]

Real DH_Total (Target value)= DH_Total (Register value)+ 4

Address: 2C **DH_HS_END** (Display Horizontal Sync End)

Bit	Mode	Function
7:0	R/W	Display Horizontal Sync End[7:0]:

		Determines the width of DHS pulse in DCLK cycles
--	--	--

Address: 2D **DH_BKGD_STA_H (Display Horizontal Background Start)**

Bit	Mode	Function
7:4	--	Reserved
3:0	R/W	Display Horizontal Background Start: High Byte [11:8]

Address: 2E **DH_BKGD_STA_L (Display Horizontal Background Start)**

Bit	Mode	Function
7:0	R/W	Display Horizontal Background Start: Low Byte [7:0]

Determines the number of DCLK cycles from leading edge of DHS to first pixel of Background region.

Real DH_BKGD_STA (Target value)= DH_BKGD_STA (Register value)+ 10

Address: 2F **DH_ACT_STA_H (Display Horizontal Active Start)**

Bit	Mode	Function
7:4	--	Reserved
3:0	R/W	Display Horizontal Active Region Start: High Byte [11:8]

Address: 30 **DH_ACT_STA_L (Display Horizontal Active Start)**

Bit	Mode	Function
7:0	R/W	Display Horizontal Active Region Start: Low Byte [7:0]

Determines the number of DCLK cycles from leading edge of DHS to first pixel of Active region.

Real DH_ACT_STA (Target value)= DH_ACT_STA (Register value)+ 10

Address: 31 **DH_ACT_END_H (Display Horizontal Active End)**

Bit	Mode	Function
7:4	--	Reserved
3:0	R/W	Display Horizontal Active End: High Byte [11:8]

Address: 32 **DH_ACT_END_L (Display Horizontal Active End)**

Bit	Mode	Function
7:0	R/W	Display Horizontal Active End: Low Byte [7:0]

Determines the number of DCLK cycles from leading edge of DHS to the pixel of background region.

Real DH_ACT_END (Target value)= DH_ACT_END (Register value)+ 10

Address: 33 **DH_BKGD_END_H (Display Horizontal Background End)**

Bit	Mode	Function
7:4	--	Reserved
3:0	R/W	Display Horizontal Background end: High Byte [11:8]

Address: 34 **DH_BKGD_END_L (Display Horizontal Background End)**

Bit	Mode	Function
7:0	R/W	Display Horizontal Background end: Low Byte [7:0]

Real DH_BKGD_END (Target value) = DH_BKGD_END (Register value)+ 10

Address: 35 DV_TOTAL_H (Display Vertical Total Lines)

Bit	Mode	Function
7:4	--	Reserved to 0
3:0	R/W	Display Vertical Total: High Byte [11:8]

Address: 36 DV_TOTAL_L (Display Vertical Total Lines)

Bit	Mode	Function
7:0	R/W	Display Vertical Total: Low Byte [7:0]

CR35, CR36 use as watch dog reference value in *frame sync* mode, the event should be active when the line number of display HS is equal to DV Total.

Address: 37 DVS_END (Display Vertical Sync End)

Bit	Mode	Function
7:5	--	Reserved
4:0	R/W	Display Vertical Sync End[4:0]: Determines the duration of DVS pulse in lines

Address: 38 DV_BKGD_STA_H (Display Vertical Background Start)

Bit	Mode	Function
7:4	--	Reserved
3:0	R/W	Display Vertical Background Start: High Byte [11:8] Determines the number of lines from leading edge of DVS to first line of background region.

Address: 39 DV_BKGD_STA_L (Display Vertical Background Start)

Bit	Mode	Function
7:0	R/W	Display Vertical Background Start: Low Byte [7:0]

Address: 3A DV_ACT_STA_H (Display Vertical Active Start)

Bit	Mode	Function
7:4	--	Reserved
3:0	R/W	Display Vertical Active Region Start: High Byte [11:8] Determines the number of lines from leading edge of DVS to first line of active region.

Address: 3B DV_ACT_STA_L (Display Vertical Active Start)

Bit	Mode	Function
7:0	R/W	Display Vertical Active Region Start: Low Byte [7:0]

Address: 3C DV_ACT_END_H (Display Vertical Active End)

Bit	Mode	Function
7:4	--	Reserved
3:0	R/W	Display Vertical Active Region End: High Byte [11:8]

Address: 3D DV_ACT_END_L (Display Vertical Active End)

Bit	Mode	Function
7:0	R/W	Display Vertical Active Region End: Low Byte [7:0]

Determine the number of lines from leading edge of DVS to the line of following background region.

Address: 3E DV_BKGD_END_H (Display Vertical Background End)

Bit	Mode	Function
7:4	--	Reserved to 0
3:0	R/W	Display Vertical Background end: High Byte [11:8]

Address: 3F DV_BKGD_END_L (Display Vertical Background End)

Bit	Mode	Function
7:0	R/W	Display Vertical Background End: Low Byte [7:0]

Determine the number of lines from leading edge of DVS to the line of start of vertical blanking.

Realtek Confidential

Frame Sync Fine Tune

Address: 40 **IVS2DVS_DEALY_LINES (IVS to DVS Lines)** **Default: 00h**

Bit	Mode	Function
7:0	R/W	IVS to DVS Lines: (Only for FrameSync Mode) The number of input HS from IVS to DVS. Should be double buffer by CR05[5:4]

Address: 41 **IV_DV_DELAY_CLK_ODD (Frame Sync Delay Fine Tuning)** **Default: 00h**

Bit	Mode	Function
7:0	R/W	Frame Sync Mode Delay Fine Tune [7:0] “00” to disable Applied to all fields when Interlaced_FS_Delay_Fine_Tuning is disabled (CR43[1] = 0) Only for odd-field when Interlaced_FS_Delay_Fine_Tuning is enabled (CR43[1] = 1)

In Frame Sync Mode , CR40[7:0] represents output VS delay fine-tuning. For example, it delays the number of (CR41 [7:0] *16 + 16) input clocks. Fill 00h, means 0, fill 01h, and means 32

Address: 42 **IV_DV_DELAY_CLK_EVEN (Frame Sync Delay Fine Tuning)** **Default: 00h**

Bit	Mode	Function
7:0	R/W	Frame Sync Mode Delay Fine Tune [7:0] “00” to disable Only for even-field when Interlaced_FS_Delay_Fine_Tuning is enabled (CR43[1] = 1)

Address: 43 **FS_DELAY_FINE_TUNING** **Default: 00h**

Bit	Mode	Function
7:3	R/W	Frame Sync Mode Fine Tune[4:0]: Reference to Fine Tune Delay Mode Select
2	R/W	Fine Tune Delay Mode Select 0: 0/32 -- 2/32 -- 4/32 -- 6/32 ~~~ 62/32 1: 0/32 -- 4/32 -- 8/32 --12/32 ~~~ 124/32
1	R/W	Interlaced_FS_Delay_Fine_Tuning 0: Disable (Default) 1: Enable
0	R/W	Internal ODD-signal inverse for Interlaced_FS_Delay_Fine_Tuning 0: No invert (Default) 1: Invert

Address: 44 **LAST_LINE_H** **Default: 00h**

Bit	Mode	Function
7	R/W	Last-line-width / DV-Total Selector : 0: CR44 [3:0] and CR45 indicate last-line width counted by display clock (Default) 1: CR44 [3:0] and CR45 indicate DHS total number between 2 DVS.
6	R/W	DV sync with 4X clock

		0: Disable 1: Enable
5	R/W	BIST Test Enable 0: Disable 1: Enable (Auto clear when finish)
4	R/W	BIST Test Result 0: Fail 1: Ok
3:0	R	DV Total or Last Line Width[11:8] Before Sync in Frame Sync Mode

Address: 45 LAST_LINE_L

Bit	Mode	Function
7:0	R	DV Total or Last Line Width[7:0] Before Sync in Frame Sync Mode

Display Fine Tune

Address: 46 DIS_TIMING (Display Clock Fine Tuning Register)

Default: 00h

Bit	Mode	Function
7	R/W	Reserved to 0
6:4	R/W	Display Output Clock Fine Tuning Control: 000: DCLK rising edge correspondents with output display data 001: 1ns delay 010: 2ns delay 011: 3ns delay 100: 4ns delay 101: 5ns delay 110: 6ns delay 111: 7ns delay
3	R/W	ACLK/BCLK Output Enable (Only used in 6 bit TTL/smart panel, otherwise, use DCLK) 0: Disable 1: Enable
2	R/W	ACLK(6 bit)/DCLK(8 bit) Polarity Inverted 0: Disable 1: Enable
1	R/W	DCLK Output Enable 0: Disable 1: Enable
0	R/W	BCLK(6 bit) Polarity Inverted

	0: Non-Inverted
	1: Inverted

Realtek Confidential

Sync Processor

Address: 47 **SYNC_SELECT**
Default: 00h

Bit	Mode	Function
7	R/W	Sync Processor Power Down (Stop Crystal Clock In) 0: Normal Run (Default) 1: Power Down
6	R/W	De-composite type Selection 0:SOY(Default) 1:CS/SOG
5	R/W	De-composite circuit enable 0: Disable (Default) 1: Enable
4	R/W	Input HS selection 0 : HS_RAW(SS/CS) (Default) 1: SOG/SOY
3	R/W	Set to 0
2	R/W	Set to 0
1	R/W	Measured by Crystal clock (Result showed in CR59) (in Digital Mode) 0: Input Active Region (Vertical IDEN start to IDEN stop) (measure at IDEN STOP) (Default) 1: Display Active Region(Vertical DEN start to DEN stop) (measure at DEN STOP) The function should work correctly when IVS or DVS occurs.
0	R/W	HSYNC & VSYNC Measured Mode 0: HS period counted by crystal clock & VS period counted by HS (Analog mode) (Default) 1: Horizontal resolution counted by input clock & V resolution counted by ENA (Digital mode) (Get the correct resolution which is triggered by enable signal, ENA)

Address: 48 **SYNC_INVERT**
Default: 00h

Bit	Mode	Function
7	R/W	COAST Signal Invert Enable: 0: Not inverted (Default) 1: Inverted
6	R/W	COAST Signal Output Enable: 0: Disable (Default) 1: Enable
5	R/W	HS_OUT Signal Invert Enable:

		0: Not inverted (Default) 1: Inverted
4	R/W	HS_OUT Signal Output Enable: 0: Disable (Default) 1: Enable
3	R/W	CS_RAW Inverted Enable 0: Normal (Default) 1: Invert
2	R/W	CLAMP Signal Output Enable 0: Disable (Default) 1: Enable
1	R/W	HS Recovery in Coast 0: Disable (Default) (SS/SOY) 1: Enable (CS or SOG)
0	R/W	HSYNC Synchronize source 0: AHS (Default) 1: Feedback HS

Address: 49
SYNC_CTRL (SYNC Control Register)
Default: 02h

Bit	Mode	Function
7	R/W	CLK Inversion to latch Feedback HS for Coast Recovery (Coast Recovery means HS feedback to replace input HS) 0: Non Inversion (Default) 1: Inversion
6	R/W	Select HS_OUT Source Signal 0: Bypass (SeHs)(Use in Separate Mode) 1: Select De-Composite HS out(DeHs) (In Composite mode)
5	R/W	Select ADC_VS Source Signal 0: VS_RAW 1: DeVS
4	R/W	CLK Inversion to latch HS_OUT for Clamp 0: Non Inversion (Default) 1: Inversion
3	R/W	Inversion of HS to measure Vsync 0: Non Inversion (Default) 1: Inversion
2	R/W	HSYNC Measure Source(ADC_HS)

		0: Select ADC_HS (Default) 1: Select SeHS or DeHS by CR49[6]
1:0	R/W	Measure HSYNC/VSYNC Source Select: 00: TMDS (Default) 01: VIDEO8 10: AHS/ADC_VS 11: Reserved

Y-Pb-Pr Control

Address: 4A **DETECT_HSYNC_PERIOD_MSB**

Bit	Mode	Function
7:0	R	Detected_Hsync_Period[10:3] MSB Hsync period counted by crystal-clock.

Address: 4B **DETECT_HSYNC_PERIOD_LSB**

Bit	Mode	Function
7	R	Hsync_Period_Detect_Reset_Status (Write Clear)
6	R	The toggling of polarity of YPbPr Field happens 0: No toggle 1: Toggle
5:3	R	The number of input HS between 2 input VSYNC. LSB bit [2:0] for YPbPr
2:0	R	Detected_Hsync_Period[2:0] LSB Hsync period counted by crystal-clock.

Address: 4C **VSYNC_COUNTER_LEVEL_MSB** **Default: 03h**

Bit	Mode	Function
7:6	--	Reserved
5	R/W	Video switch 0: NA (Default) 1: Video8 (Should power on ADC Band-gap CRE8[3])
4	R/W	SOY De-Composite 0: Auto period de-composite (Default) 1: Force period de-composite
3	R/W	Pop up Detected_Hsync_Period 0: no pop up 1: pop up result (CR4A[7:0], CR4B[2:0])
2:0	R/W	Vsync counter level count [10:8] MSB

		Vsync detection counter start value.
--	--	--------------------------------------

Address: 4D **VSYNC_COUNTER_LEVEL_LSB** **Default: 00h**

Bit	Mode	Function
7:0	R/W	Vsync counter level count [7:0] LSB

Address: 4E **SYNC_POLARITY_PERIOD_COUNT** **Default: 50h**

Bit	Mode	Function
7:0	R/W	Sync polarity period count number [8:1]

Address: 4F **STABLE COUNT** **Default: 00h**

Bit	Mode	Function
7	---	Reserved to 0
6	R	HSYNC Polarity Change (write clear) flag will be cleared when this byte being accessed
5	R/W	Vsync measure invert Enable 0: Disable (Default) 1: Enable
4	R/W	Pop Up Stable Period and Polarity Value 0: No Pop Up (Default) 1: Pop Up Result, (CR50[2:0],CR51)
3	R/W	Stable Period Tolerance 0: ± 2 crystal clks (Default) 1: ± 4 crystal clks
2	R/W	Stable Count 0: 32 lines (Default) 1: 64 lines
1	R/W	Polarity measure method 0: High / Low compare (Default) 1: Fix-Length (The length is decided by CR4E.)
0	R/W	Stable Measure Start 0: Stop (Default) 1: Start (Clear CR4F[6], CR50 and CR51)

Address: 50 **Stable_Period_H**

Bit	Mode	Function
7	R	HS Overflow(16-bits) (only be cleared when set CR4F[0]=1)
6	R	Stable Period Change (only be cleared when set CR4F[0]=1)
5	R	Stable Polarity Change (only be cleared when set CR4F[0]=1)
4	R	Stable Flag (only be cleared when re-measured set CR4F[0]=1) 0: Period or polarity can't get continuous stable status.

		1: Both polarity and period are stable.
3	R	Stable Polarity (on line monitor) 0: Negative 1: Positive Compare each line's polarity; if we get continuous N lines with the same one, the polarity is updated as the stable polarity. N is determined by CR4F [2]. Detect method is determined by CR4F [1].
2:0	R	Stable Period[10:8] Compare each line's period, if we get continuous N lines with the same one, the period is updated as the stable period. N is determined by CR4F [2].

Address: 51 **STABLE_PERIO_L**

Bit	Mode	Function
7:0	R	Stable Period[7:0] Compare each line's period, if we get continuous N lines with the same one, the period is updated as the stable period. N is determined by CR4E[2]

Address: 52 **MEAS_HS_PER_H (HSYNC Period Measured Result)** **Default: 0xh**

Bit	Mode	Function
7	R/W	On Line Auto Measure Enable 0: Disable (Default) 1: Enable
6	R/W	Pop Up Period Measurement Result 0: No Pop Up (Default) 1: Pop Up Result
5	R/W	Start a HS & VS period / H & V resolution & polarity measurement (on line monitor) 0: Finished/Disable (Default) 1: Enable to start a measurement, auto cleared after finished
4	R	Over-flow bit of Input HSYNC Period Measurement 0: No Over-flow occurred 1: Over-flow occurred
3:0	R	Input HSYNC Period Measurement Result: High Byte[11:8]

Address: 53 **MEAS_HS_PERIOD_L (HSYNC Period Measured Result)**

Bit	Mode	Function
7:0	R	Input HSYNC Period Measurement Result: Low Byte[7:0]

I This result is expressed in terms of crystal clocks.

I When measured digitally, the result is expressed as the number of input clocks between 2 input HS signals

Address: 54 **MEAS_VS_PERIOD_H (VSYNC Period Measured Result)**

Bit	Mode	Function
7	R	Input VSYNC Polarity Indicator 0: negative polarity (high period is longer than low one) 1: positive polarity (low period is longer than high one)
6	R	Input HSYNC Polarity Indicator 0: negative polarity (high period is longer than low one) 1: positive polarity (low period is longer than high one)
5	R	Time-Out bit of Input VSYNC Period Measurement (No VSYNC occurred) 0: No Time Out 1: Time Out occurred
4	R	Over-flow bit of Input VSYNC Period Measurement 0: No Over-flow occurred 1: Over-flow occurred
3:0	R	Input VSYNC Period Measurement Result: High Byte[11:8]

Address: 55 MEAS_VS_PERIOD_L (VSYNC Period Measured Result)

Bit	Mode	Function
7:0	R	Input VSYNC Period Measurement Result: Low Byte[7:0]

I This result is expressed in terms of input HS pulses.

I When measured digitally, the result is expressed as the number of input ENA signal within a frame.

Address: 56 MEAS_HS_VS_HIGH_PERIOD_H (HSYNC&VSYNC High Period Measured Result)

Bit	Mode	Function
7:4	R	Input VSYNC High Period Measurement Result: High Byte[11:8]
3:0	R	Input HSYNC High Period Measurement Result: High Byte[11:8]

Address: 57 MEAS_HS_HIGH_PERIOD_L (HSYNC High Period Measured Result)

Bit	Mode	Function
7:0	R	Input HSYNC High Period Measurement Result: Low Byte[7:0]

This result is expressed in terms of crystal clocks. When measured digitally, the result is expressed as the number of input clocks inside the input enable signal

Address: 58 MEAS_VS_HIGH_PERIOD_L (VSYNC High Period Measured Result)

Bit	Mode	Function
7:0	R	Input VSYNC High Period Measurement Result: Low Byte[7:0]

This result is expressed in terms of input HS pulses

Address: 59 MEAS_ACTIVE_REGION_H (Active Region Measured by CRSTL_CLK Result)

Bit	Mode	Function
7:0	R/W	Active Region Measured By Crystal Clock 1 st read: Measurement Result: High Byte[23:16]

		2nd read: Measurement Result: High Byte[15:8] 3rd read: Measurement Result: High Byte[8:0] Read pointer is auto increase, if write, the pointer is also reset to 1 st result.
--	--	--

Address: 5A **CLAMP_START (Clamp Signal Output Start)** **Default: 10h**

Bit	Mode	Function
7:0	R/W	Start of Output Clamp Signal Pulse[7:0]: Determine the number of input double-pixel between the trailing edge of input HSYNC and the start of the output CLAMP signal.

Address: 5B **CLAMP_END (Clamp Signal Output End)** **Default: 14h**

Bit	Mode	Function
7:0	R/W	End of Output Clamp Signal Pulse[7:0]: Determine the number of input double-pixel between the trailing edge of input HSYNC and the end of the output CLAMP signal.

Address: 5C **CLAMP_CTRL0** **Default:00h**

Bit	Mode	Function
7	R/W	Clamp Mask Enable 0: Disable (Default) 1: Enable
6	R/W	CLAMP_Trigger_Edge_Inverse 0: Trailing edge (Disable) 1: Leading edge
5:0	R/W	Mask Line Number before VS [5:0]

Address: 5D **CLAMP_CTRL1** **Default: 00h**

Bit	Mode	Function
7	R/W	Sync Processor Test Mode 0: Normal (Default) 1: Enable Test Mode; (switch 70ns-ck to the time-out & polarity counters)
6	R/W	Select Clamp Mask as De VS 0: Disable 1: Enable
5:0	R/W	Mask Line Number after VS [5:0]

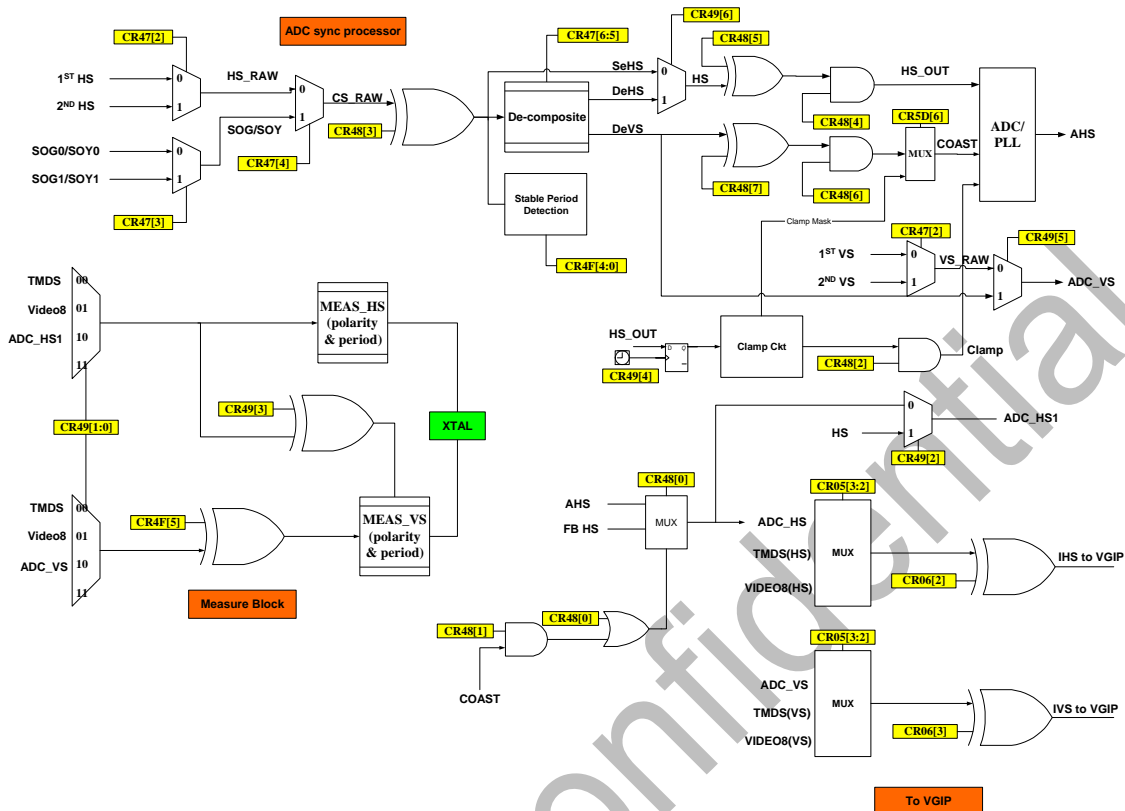

Figure 19 Sync processor

Color Processor Control

Address: 5E

COLOR_CTRL (Color Control Register)

Default: 00h

Bit	Mode	Function
7	--	Reserved to 0
6	R/W	sRGB precision 0: Normal (Default) 1: 1 bit shift
5:3	R/W	sRGB Coefficient Write Enable 000: Disable 001: Write R Channel (RRH,RRL,RGH,RGL,RBH,RBL) (address reset to 0 when written) 010: Write G Channel (GRH,GBL,GGH,GGL,GBH,GBL) (address reset to 0 when written) 011: Write B Channel (BRH,BRL,BGH,BGL,BBH,BBL) (address reset to 0 when written) 100: R Offset (if users don't need to use offset, set it to 0) 101: G Offset (if users don't need to use offset, set it to 0)

		110: B Offset (if users don't need to use offset, set it to 0)
2	R/W	Enable sRGB Function 0: Disable (Default) 1: Enable
1	R/W	Enable Contrast Function: 0: disable the coefficient (Default) 1: enable the coefficient
0	R/W	Enable Brightness Function: 0: disable the coefficient (Default) 1: enable the coefficient

Address: 5F SRGB_ACCESS_PORT

Bit	Mode	Function
7:0	W	sRGB_COEF[7:0]

- | For Multiplier coefficient: 9 bit: 1 bit sign, 8 bit fractional part
- | For filling multiplier coefficient, the sequence should be SIGN bit (High Byte), 8 bit fractional (Low Byte)
- | For Offset Coefficient: 1 sign, 5 integer, 2 bit fractional part
- | sRGB output saturation to 1023 and Clamp to 0
- | sRGB Output is 10 bit

$$\begin{bmatrix} R' \\ G' \\ B' \end{bmatrix} = \begin{bmatrix} 1+RR & RG & RB \\ GR & 1+GG & GB \\ BR & BG & 1+BB \end{bmatrix} \begin{bmatrix} R + Roffset \\ G + Goffset \\ B + Boffset \end{bmatrix}$$

Brightness Coefficient:

Address: 60 BRI_RED_COE (Brightness Red Coefficient)

Bit	Mode	Function
7:0	R/W	Brightness Red Coefficient: Valid range: -128(00h) ~ 0(80h) ~ +127(FFh)

Address: 61 BRI_GRN_COE (Brightness Green Coefficient)

Bit	Mode	Function
7:0	R/W	Brightness Green Coefficient: Valid range: Valid range: -128(00h) ~ 0(80h) ~ +127(FFh)

Address: 62 BRI_BLU_COE (Brightness Blue Coefficient)

Bit	Mode	Function
7:0	R/W	Brightness Blue Coefficient:

	Valid range: -128(00h) ~ 0(80h) ~ +127(FFh)
--	---

Contrast Coefficient:
Address: 63 **CTS_RED_COE (Contrast Red Coefficient)** **Default: 80h**

Bit	Mode	Function
7:0	R/W	Contrast Red Coefficient: Valid range: 0(00h) ~ 1(80h) ~ 2(FFh)

Address: 64 **CTS_GRN_COE (Contrast Green Coefficient)** **Default: 80h**

Bit	Mode	Function
7:0	R/W	Contrast Green Coefficient: Valid range: 0(00h) ~ 1(80h) ~ 2(FFh)

Address: 65 **CTS_BLU_COE (Contrast Blue Coefficient)** **Default: 80h**

Bit	Mode	Function
7:0	R/W	Contrast Blue Coefficient: Valid range: 0(00h) ~ 1(80h) ~ 2(FFh)

Gamma Control
Address: 66 **GAMMA_PORT**

Bit	Mode	Function
7:0	W	Access port for gamma correction table (First, users should turn on DCLK and then fill the coefficient)

l The input data sequence is {g0[9:2]}, {g0[1:0], 1'b0, d0[4:0]}, {3'b0, d1[4:0]}; {g2[9:2]}, {g2[1:0], 1'b0, d2[4:0]}, {3'b0, d3[4:0]}; ...; {g254[9:2]}, {g254[1:0], 1'b0, d254[4:0]}, {3'b0, d255[4:0]} for full gamma table.

l The input data sequence is {g0[9:2]}, {g0[1:0], 1'b0, d0[4:0]}, {g2[9:2]}, {g2[1:0], 1'b0, d2[4:0]} ... , {g254[9:2]}, {g254[1:0], 1'b0, d254[4:0]} for compact gamma table.

l For compact gamma table, d1[4:0]=d0[4:0], d3[4:0]=d2[4:0], ... , d(2n+1)[4:0]=d(2n)[4:0].

l g(n) is 10bit gamma coefficient, and d(n) is g(n+1) – g(n) with 5bit.

l If n is even, Gamma-port output is g(n) + d(n)*(2bit LSB brightness output)/4.

l If n is odd, Gamma-port output is g(n-1) + d(n-1) + d(n)*(2bit LSB brightness output)/4.

l Gamma can be only accessed when DCLK exists.

l The latest stage of d[n] can't let gamma curve exceed 255.

Address: 67 **GAMMA_CTRL** **Default: 00h**

Bit	Mode	Function
7	R/W	Enable Access Channels for Gamma Correction Coefficient:

		0: disable these channels (Default) 1: enable these channels
6	R/W	Gamma table enable 0: by pass (Default) (Choose this mode when updating Gamma table) 1: enable
5:4	R/W	Color Channel of Gamma Table 00: Red Channel (Default) 01: Green Channel 10: Blue Channel 11: Red/Green/Blue Channel (R/G/B Gamma are the same)
3:1	--	Reserved to 0
0	R/W	Gamma Access Type 0: access compact gamma table (Default) 1: access full gamma table

! Access Gamma_Access register will reset GAMMA_PORT index.

Address: 68 **GAMMA_BIST (Color Control Register)** Default: 01h

Bit	Mode	Function
7	R/W	Test_mode 0: Disable, dither_out = dither_result[9:2]; // truncate to integer number (Default) 1: Enable, dither_out = dither_result[7:0]; // propagate decimal part for test
6:4	--	Reserved to 0
3:2	R/W	Gamma BIST select 00: BIST Disable (Default) 01: Red LUT 10: Green LUT 11: Blue LUT
1	R/W	Gamma BIST Progress 0: BIST is done (Default) 1: BIST is running
0	R	Gamma BIST Test Result 0: SRAM Fail 1: SRAM OK

Dithering Control

Address: 69 **DITHERING_SEQUENCE_TABLE**

Bit	Mode	Function
7:6	W	Dithering Sequence Table (SR3)
5:4	W	Dithering Sequence Table (SR2)
3:2	W	Dithering Sequence Table (SR1)

1:0	W	Dithering Sequence Table (SR0)
-----	---	--------------------------------

- I There are three set of dithering sequence table, each table contains 32 elements, s0, s1, ... , s31.
Each element has 2 bit to index one of 4 dithering table.
- I Input data sequence is {sr3,sr2,sr1,sr0}, {sr7,sr6,sr5,sr4}, ... , {sr31,sr30,sr29,sr28}, {sg3,sg2,sg1,sg0}, ... , {sg31,sg30,sg29,sg28}, {sb3,sb2,sb1,sb0}, ... , {sb31,sb30,sb29,sb28} for red, green and blue channel.
- I $R + (2R+1) * C$ choose sequence element, where R is Row Number / 2, and C is Column Number / 2.

Address: 6A DITHERING_TABLE_ACCESS (Dithering Table Access Port)

Bit	Mode	Function
7:4	W	Access port for dithering table D00/D02/ D10/D12/D20/D22/D30/D32
3:0	W	Access port for dithering table D01/D03/ D11/D13/D21/D23/D31/D33

- I Red, green, blue each channel has 4 dithering table, each table is 2x2 elements, and one element has 4 bit for 10B/8B, the elements should fill 0 to 3, for 10B/6B, the elements should fill 0 to 15.
- I Input data sequence is [Dr00 Dr01],[Dr02,Dr03], ... , [Dr30,Dr31],[Dr32,Dr33], [Dg00,Dg01],[Dg02,Dg03], ... , [Dg30,Dg31],[Dg32,Dg33], [Db00,Db01],[Db02,Db03], ... , [Db30,Db31],[Db32,Db33].

D00	D01	D10	D11	D20	D21	D30	D31
D02	D03	D12	D13	D22	D23	D32	D33

Address: 6B DITHERING_CTRL Default: 00h

Bit	Mode	Function
7	R/W	Enable Access Dithering Sequence Table 0: disable (Default) 1: enable
6	R/W	Enable Access Dithering Table 0: disable (Default) 1: enable
5	R/W	Enable Dithering Function 0: disable (Default) 1: enable
4	R/W	Temporal Dithering 0: Disable (Default) 1: Enable
3	R/W	Dithering Table Value Sign 0: unsigned 1: signed (2's complement)
2	R/W	Dithering Mode 0: New (Default) 1: Old
1	R/W	Vertical Frame Modulation 0: Disable (Default)

		1: Enable
0	R/W	Horizontal Frame Modulation 0: Disable (Default) 1: Enable

! {Dithering sequence + Frame Number (if temporal dithering)} mod 4 determine which dithering table to use

Realtek Confidential

Overlay/Color Palette/Background Color Control

Address: 6C **OVERLAY_CTRL (Overlay Display Control Register)** **Default: 00h**

Bit	Mode	Function
7:6	--	Reserved to 0
5	R/W	Background color access enable 0: Disable(Reset CR6D Write Pointer to R) 1: Enable
4:2	R/W	Alpha blending level (Also enable OSD frame control register 0x003 byte 1[3:2]) 000: Disable (Default) 001 ~111: 1/8~ 7/8
1	R/W	Overlay Sampling Mode Select: 0: single pixel per clock (Default) 1: dual pixels per clock (The OSD will be zoomed 2X in horizontal scan line)
0	R/W	Overlay Port Enable: 0: Disable (Default) 1: Enable Turn off <u>overlay enable</u> and <u>switch to background</u> simultaneously when auto switch to background.

Address: 6D **BGND_COLOR_CTRL** **Default: 00h**

Bit	Mode	Function
7:0	R/W	Background color RGB 8-bit value[7:0]

! There are 3 bytes color select of background R, G, B, once we enable Background color access channel(CR6C[5]) and the continuous writing sequence is R/G/B

Address: 6E **OVERLAY_LUT_ADDR (Overlay LUT Address)** **Default: 01h**

Bit	Mode	Function
7	--	Reserved to 0
6	R/W	Enable Overlay Color Plate Access: 0: Disable (Default) 1: Enable
5:0	R/W	Overlay 16x24 Look-Up-Table Write Address [5:0]

! Auto-increment while every accessing "Overlay LUT Access Port".

Address: 6F **COLOR_LUT_PORT (LUT Access Port)**

Bit	Mode	Function
7:0	W	Color Palette 16x24 Look-Up-Table access port [7:0]

! Using this port to access overlay color plate which addressing by the above registers.

- I The writing sequence into LUT is [R0, G0, B0, R1, G1, B1, ... R15, G15, and B15] and the address counter will be automatic increment and circular from 0 to 47.

Image Auto Function

Address: 70 **H_BOUNDARY_H** **Default: 33h**

Bit	Mode	Function
7	--	Reserved
6:4	R/W	Horizontal Boundary Start: High Byte [10:8]
3:0	R/W	Horizontal Boundary End: High Byte [11:8]

Address: 71 **H_BOUNDARY_STA_L** **Default: 04h**

Bit	Mode	Function
7:0	R/W	Horizontal Boundary Start: Low Byte [7:0]

Address: 72 **H_BOUNDARY_END_L** **Default: C0h**

Bit	Mode	Function
7:0	R/W	Horizontal Boundary End: Low Byte [7:0]

Address: 73 **V_BOUNDARY_H** **Default: 85h**

Bit	Mode	Function
7	--	Reserved
6:4	R/W	Vertical Boundary Start: High Byte [10:8]
3:0	R/W	Vertical Boundary End: High Byte [11:8]

Vertical boundary search should be limited by Vertical boundary start.

Address: 74 **V_BOUNDARY_STA_L** **Default: 20h**

Bit	Mode	Function
7:0	R/W	Vertical Boundary Start: Low Byte [7:0]

Address: 75 **V_BOUNDARY_END_L** **Default: 42h**

Bit	Mode	Function
7:0	R/W	Vertical Boundary End: Low Byte [7:0]

Address: 76 **RED_NOISE_MARGIN (Red Noise Margin Register)** **Default: 00h**

Bit	Mode	Function
7:2	R/W	Red pixel noise margin setting register
1:0	--	Reserved to 0

Address: 77 **GRN_NOISE_MARGIN (Green Noise Margin Register)** **Default: 80h**

Bit	Mode	Function
7:2	R/W	Green pixel noise margin setting register
1:0	--	Reserved to 0

Address: 78 **BLU_NOISE_MARGIN (Blue Noise Margin Register)** **Default: 18h**

Bit	Mode	Function
7:2	R/W	Blue pixel noise margin setting register
1:0	--	Reserved to 0

Address: 79 **DIFF_THRESHOLD** **Default: 85h**

Bit	Mode	Function
7:0	R/W	Difference Threshold

Address: 7A **AUTO_ADJ_CTRL0** **Default: 00h**

Bit	Mode	Function
7	R/W	Field_Select_Enable: Auto-Function only active when Even or Odd field. 0: Disable (Default) 1: Enable
6	R/W	Field_Select: Select Even or Odd field. Active when Field_Select_Enable (CR7A[7]) . 0: Active when ODD signal is "0" (Default) 1: Active when ODD signal is "1"
5	R/W	Even or Odd pixel be measured 0: Even (Default) 1: Odd
4	R/W	Measure only Even or Odd pixel enable 0: Disable (Default) 1: Enable
3:2	R/W	Vertical boundary search: 00: 1 pixel over threshold (Default) 01: 2 pixel over threshold 10: 4 pixel over threshold 11: 8 pixel over threshold
1:0	R/W	Color Source Select for Detection: 00: B color (Default) 01: G color 10: R color 11: ALL (when using "ALL" mode, the result SOD value will be right shift 1 bit) Measure ALL R/G/B can be done in three frames

Address: 7B **HW_AUTO_PHASE_CTRL0** **Default: 00h**

Bit	Mode	Function
7:3	R/W	Number of Auto-Phase Step (Valut+1) (How many times (steps reference CR7B[2:0]) jumps when using Hardware Auto)

2:0	R/W	Hardware Auto Phase Step 000: Step =1 (Default) 001 Step =2 010: Step =4 011: Step =8 1xx: Step =16
-----	-----	---

Address: 7C HW_AUTO_PHASE_CTRL1 Default: 00h

Bit	Mode	Function
7	R/W	Hardware Auto Phase Select Trigger 0: IVS 1: Vertical Boundary End
6	R/W	Low Pass Filter (121-LPF) 0: Disable (Default) 1: Enable
5:0	R/W	Initial phase of Auto-Phase (0~63) For High Freq: the phase sequence is 0,1,2.....,63 (Default) For Low Freq: the phase sequence is 0,2,4,6,8.....,126

Address: 7D AUTO_ADJ_CTRL1 Default: 00h

Bit	Mode	Function
7	R/W	Measure Digital Enable Info when boundary search active 0: Normal Boundary Search (Default) 1: Digital Enable Info Boundary Search.(Digital mode)
6	R/W	Hardware / Software Auto Phase Switch 0: Software (Default) 1: Hardware
5	R/W	Color Max or Min Measured Select: 0: MIN color measured (Only when Balance-Mode, result must be complemented) (Default) 1: MAX color measured
4	R/W	Accumulation or Compare Mode 0: Compare Mode (Default) 1: Accumulation Mode
3	R/W	Phase Determination Method Selection 0: Edge Mode (Original TYPE II MODE I) (Default) 1: Edge + Pulse Mode
2	--	Reserved to 0
1	R/W	Function (Phase/Balance) Selection

		0: Auto-Balance (Default) 1: Auto-Phase
0	R/W	Start Auto-Function Tracking Function: 0: stop or finished (Default) 1: start

Control Table/ Function	Sub-Function	CR7D.6	CR7D.5	CR7D.4	CR7D.3	CR7D.1	CR79
Auto-Balance	Max pixel	X	1	0	0	0	X
	Min pixel	X	0	0	0	0	X
Auto-Phase Type	Mode1	1	1	1	0	1	Th
	Mode2	1	1	1	1	1	Th
Accumulation	All pixel	1	1	1	0	0	0

Table 1 Auto-Tracking Control Table

Address: 7E VER_START_END_H (Active region vertical start Register)

Bit	Mode	Function
7:4	R	Active region vertical START measurement result: bit[11:8]
3:0	R	Active region vertical END measurement result: bit[11:8]

Address: 7F VER_START_L (Active region vertical start Register)

Bit	Mode	Function
7:0	R	Active region vertical start measurement result: bit[7:0]

Address: 80 VER_END_L (Active region vertical end Register)

Bit	Mode	Function
7:0	R	Active region vertical end measurement result: bit[7:0]

Address: 81 H_START_END_H (Active region horizontal start Register)

Bit	Mode	Function
7:4	R	Active region horizontal START measurement result: bit [11:8]
3:0	R	Active region horizontal END measurement result: bit[11:8]

Address: 82 H_START_L (Active region horizontal start Register)

Bit	Mode	Function
7:0	R	Active region horizontal start measurement result: bit[7:0]

Address: 83 H_END_L (Active region horizontal end Register)

Bit	Mode	Function
7:0	R	Active region horizontal end measurement result: bit[7:0]

Address: 84 AUTO_PHASE_3 (Auto phase result byte3 register)

Bit	Mode	Function
7:0	R	Auto phase measurement result: bit[31:24]

Address: 85 **AUTO_PHASE_2** (Auto phase result byte2 register)

Bit	Mode	Function
7:0	R	Auto phase measurement result: bit[23:16]

Address: 86 **AUTO_PHASE_1** (Auto phase result byte1 register)

Bit	Mode	Function
7:0	R	Auto phase measurement result: bit[15:8]

Address: 87 **AUTO_PHASE_0** (Auto phase result byte0 register)

Bit	Mode	Function
7:0	R	Auto phase measurement result: bit[7:0] The measured value of R or G or B color max or min. (Auto-Balance)

Address: 88 *Reserved to 0*

Video (Color Space Conversion)

Address: 89 **YUV2RGB_CTRL** (YUV to RGB Control Register) **Default: 00h**

Bit	Mode	Function
7:5	R/W	YUV Coefficient Write Enable: 000: h12 high byte 001: h12 low byte 010: h22 high byte 011: h22 low byte 100: h23 high byte 101: h23 low byte 110: h33 high byte 111: h33 low byte
4	--	Reserved to 0
3	R/W	Enable YUV/RGB coefficient Access: 0: Disable 1: Enable
2	R/W	Cb Cr Clamp 0: Bypass 1: Cb-128, Cr-128
1	R/W	Y Gain/Offset: 0: Bypass 1: (Y-16)*1.164

0	R/W	Enable YUV to RGB Conversion: 0: Disable YUV-to-RGB conversion (Default) 1: Enable YUV-to-RGB conversion
---	-----	---

Address: 8A **YUV_RGB_COEF_DATA**

Bit	Mode	Function
7:0	W	COEF_DATA[7:0]

$$\text{YUV/RGB matrix} \begin{bmatrix} R \\ G \\ B \end{bmatrix} = \begin{bmatrix} 1.164(or1) & h12 & 0 \\ 1.164(or1) & -h22 & -h23 \\ 1.164(or1) & 0 & h33 \end{bmatrix} \begin{bmatrix} Y-16(orY) \\ Cr-128 \\ Cb-128 \end{bmatrix}$$

- | h12: 11 bits, 1 bit integer and 10-bit fractional bits (Default: 5_80h)
- | h22: 10 bits, all fractional bits (Default: 1_40h)
- | h23: 9 bits, the MSB mean 0.25 (Default: 0_A0h)
- | h33: 12 bits, 2 bit integer and 10-bit fractional bits (Default: 7_00h)
- | To fill 'h' coefficients expressed by 2's complement without signed bit.
- | h22 and h23 can't be 000h
- | When enable coefficient access, the coefficient fill method should write CR89 [7:5] and then write CR8A repetitively.

Realtek Confidential

Embedded Timing Controller

Address: 8B **TCON_ADDR_PORT** **Default: 00h**

Bit	Mode	Function
7:0	R/W	Address port for embedded TCON access

Address: 8C **TCON_DATA_PORT** **Default: 00h**

Bit	Mode	Function
7:0	R/W	Data port for embedded TCON access

Address: 00 **TC_CTRL1 (Timing Controller control register1)** **Default: 01h**

Bit	Mode	Function
7	R/W	Enable Timing Controller Function (Global) 0: Disable (Default) 1: Enable Reset all TCON pins after Enable TCON function is set and ties low.
6	R/W	TCON [n] Toggle Function Reset 0: Not reset (Default) 1: reset by DVS (all registers will be set to 0)
5	R/W	Inactive Period Data Controlled by internal TCON [13] 0: DEN (Default) 1: TCON [13]
4	--	Reserved
3:2	R/W	Crystal Out Frequency (Glitch free mux) 00: 1/4 X (Default) 01: 1/2 X 1X: 1X
1:0	R/W	Display Port Configuration: 00: TTL 01: HZ (Default) 10: LVDS 11: RSDS

Address: 01 **LVDS Location Pin Driving Control** **Default: 00h**

Bit	Mode	Function
7:5	--	Reserved to 0
4	R/W	Pin110/111/112/113/114/115/118/119/120/121/122 Pin 48/49/50/51/52/53/54/55/56/57 drive current setting

		0: 4mA 1: 6mA
3:1	R/W	Display Port Driving Current Control <i>TTL:61-70,73-82,85-94, 97-106</i> <i>RSDS TYPE I: (73-82,61-70(odd/even swap=1) or (97-106,85-94(odd/even swap=0))</i> 000~111: Bit[3]*4 + Bit[2]*4 + Bit[1]*2mA <i>RSDSIII:(97-106,85-94,73-82,61-70)</i> <i>LVDS:(85-94,73-82)</i> <i>RSDS TYPE I:(73-82,61-70(odd/even swap=0) and (97-106,85-94(odd/even swap=1))</i> 000~111: Bit[3]*2 + Bit[2]*1 + Bit[1]*0.5mA + 2.5 mA
0	--	Reserved to 0

Address: 02
RSDS Misc
Default: 00h

Bit	Mode	Function
7	R/W	RSDS data latch Inverted 0: Non-Inverted 1: Inverted
6:4	R/W	RSDS data latch Delay 000: 0ns delay 001: 0.5ns delay 010: 1ns delay 011: 1.5ns delay 100: 2ns delay 101: 2.5ns delay 110: 3ns delay 111: 3.5ns delay
3	--	Reserved to 0
2	R/W	RSDS Green / Clock Pair Swap (Also refer to CR29[6:4]) 0: No Swap (Default) 1: Swap
1	R/W	RSDS High/Low Bit Swap (data) (Also refer to CR29[6:4]) 0: Swap (Default) 1: No Swap
0	R/W	RSDS Differential pair PN swap (data) (Also refer to CR29[6:4]) 0: No Swap (Default) 1: Swap

AU 17" RSDS panel pin order:
BOB1B2G0G1G2CLKR0R1R2

ODI 17" RSDS panel pin order:
B2B1B0G2G1G0CLKR2R1R0
CMO 17" RSDS panel pin order:
B2B1B0CLKG2G1G0R2R1R0
I Total swap function:

- Even/Odd swap
- Red/Blue swap
- 8 bit MSB/LSB swap
- 6 bit MSB/LSB swap
- RSDS High/Low bit swap
- RSDS P/N swap
- RSDS Green/Clk swap
- 6 bit MSB/LSB swap \Rightarrow G0 G1 G2 CK \Rightarrow G2 G1 G0 CK
- Green/Clk swap \Rightarrow G0 G1 G2 CK \Rightarrow CK G0 G1 G2
- 6 bit MSB/LSB swap first, then Green/Clk swap \Rightarrow G0 G1 G2 CK \Rightarrow G2 G1 G0 CK \Rightarrow CK G2 G1 G0

Anti-Flicker Control

Anti-flicker control is intended to switch polarity control of the panel, the hardware detects the picture condition and switch the toggle style between 1-line/2-line, and the dedicated polarity control pin is TCON 7, users should build one-line toggle in TCON6 and then TCON 7 will auto switch between 1-line/2-line polarity change.

Address: 03 Pixel Threshold High Value for Smart Polarity (TH1) Default: 00h

Bit	Mode	Function
7:0	R/W	2 line Sum of Difference Threshold 1 Value: bit [7:0] ie:TH1

Address: 04 Pixel Threshold Low Value for Smart Polarity (TH2) Default: 00h

Bit	Mode	Function
7:0	R/W	2 line Sum of Difference Threshold 2 Value: bit [7:0] ie:TH2

Address: 05 Line Threshold Value for Smart Polarity Default: 00h

Bit	Mode	Function
7	R/W	Measure Dot Pattern over Threshold 1: Run. Auto: always measure (Reference to CR05[5]) Manual: start to measure, clear after finish 0: Stop
6	R	Dot Pattern Sum of Difference Measure Result 1: Over threshold 0: Under threshold
5	R/W	Anti-Flicker Auto-Measure Control 1: Auto

		0: Manual
4:0	R/W	Over Difference Line Threshold Value: bit [4:0]

RSDS Display Data Bus Control

Address: 06 RSDS Display Data Bus Interleaving Line Buffer Length High Byte Default: 00h

Bit	Mode	Function
7	R/W	RSDS Type III Line Buffer Enable 0: Disable 1: Enable
6:5	R/W	Buffer SRAM Selection 00: Front Even-SRAM 01: Front Odd-SRAM 10: Back Even-SRAM 11: Back Odd-SRAM
4	R/W	BIST Test is running 0: Stop 1: Start
3	R/W	BIST Test result 0: Fail 1: Ok
2	R/W	Display Data Bus Interleaving Enable 0: Disable (Default) 1: Enable
1:0	R/W	Interleaving Line Buffer Line Buffer: High Byte [9:8]

Address: 07 RSDS Display Data Bus Interleaving Line Buffer Length Low Byte Default: 00h

Bit	Mode	Function
7:0	R/W	Interleaving Line Buffer Line Buffer: Low Byte [7:0]

TCON Horizontal/Vertical Timing Setting

Address: 08 TCON [0]_VS_LSB (TCON [0] Vertical Start LSB Register)

Bit	Mode	Function
7:0	W	Line number [7:0] at which TCON control generation begins

Address: 09 TCON [0]_VS_MSB (TCON [0] Vertical Start/End MSB Register)

Bit	Mode	Function
7	--	Reserved

6:4	W	Line number [10:8] at which TCON control generation ends
3	--	Reserved
2:0	W	Line number [10:8] at which TCON control generation begins

Address: 0A TCON [0]_VE_LSB (TCON [0] Vertical End LSB Register)

Bit	Mode	Function
7:0	W	Line number [7:0] at which TCON control generation ends

Address: 0B TCON [0]_HS_LSB (TCON [0] Horizontal Start LSB Register)

Bit	Mode	Function
7:0	W	Pixel count [7:0] at which TCON goes active

Address: 0C TCON [0]_HS_MSB (TCON [0] Horizontal Start/End MSB Register)

Bit	Mode	Function
7	--	Reserved
6:4	W	Pixel count [10:8] at which TCON goes inactive
3	--	Reserved
2:0	W	Pixel count [10:8] at which TCON goes active

To be triggered on rising edge of the DCLK

Address: 0D TCON [0]_HE_LSB (TCON [0] Horizontal End LSB Register)

Bit	Mode	Function
7:0	W	Pixel count [7:0] at which TCON goes inactive

If the register number is large than display format, the horizontal component is always on.

Real TCON_HS = TCON_HS-4, Real TCON_HE = TCON_HE-4

Address: 0E TCON [0]_CTRL (TCON [0] Control Register)

Default: 00h

Bit	Mode	Function
7	R/W	TCON [n] Enable (Local) 0: Disable (TCON [n] output clamp to '0') (Default) 1: Enable
6	R/W	Polarity Control 0: Normal output (Default) 1: Inverted output
5:4	--	Reserved to 0
3	R/W	Toggle Circuit Enable/Disable 0: Normal TCON output (Default) 1: Toggle Circuit enable When using toggle circuit enable mode, the TCON[n] will be 1 clock earlier than TCON[n-1] and then toggling together, finally output will be 1 clock delay comparing to toggling result.
2:0	R/W	TCON [13:10] & TCON [7:4] (TCON Combination Select)

	<p>TCON [13] has inactive data controller function.</p> <p>TCON [13]~[10] has dot masking function</p> <p>TCON [7] has flicking reduce function.</p> <p>000: Normal TCON output (Default) (When toggle enable, it will toggle itself)</p> <p>001: Select TCON [n] “AND” with TCON [n-1]</p> <p>010: Select TCON [n] “OR” with TCON [n-1]</p> <p>011: Select TCON [n] “XOR” with TCON [n-1]</p> <p>100: Select TCON [n-1] rising edge as toggle trigger signal (only when toggle enable)</p> <p>101: Select TCON [n-1] rising edge as toggle trigger signal, then “AND” (only when toggle enable)</p> <p>110: Select TCON [n-1] rising edge as toggle trigger signal, then “OR” (only when toggle enable)</p> <p>111: Select TCON [n] and TCON [n-1] on alternating frames.</p> <hr/> <p>TCON [9:8] (TCON Combination Select)</p> <p>000: Normal TCON output</p> <p>001: Select TCON [n] “AND” with TCON [n-1]</p> <p>010: Select TCON [n] “OR” with TCON [n-1]</p> <p>011: Select TCON [n] “XOR” with TCON [n-1]</p> <p>100: Select TCON [n-1] rising edge as toggle trigger signal (when toggle enable)</p> <p>101: Select TCON [n-1] rising edge as toggle trigger signal, then “AND” (when toggle enable)</p> <p>110: Select TCON [n-1] rising edge as toggle trigger signal, then “OR” (when toggle enable)</p> <p>111: Select TCON [n] and TCON [n-1] reference ODD signal as alternating frames.</p> <hr/> <p>TCON [3] (TCON Combination Select)</p> <p>000: Normal TCON output</p> <p>001: Select TCON [3] “AND” with TCON [2]</p> <p>010: Select TCON [3] “OR” with TCON [2]</p> <p>011: Select TCON [3] “XOR” with TCON [2]</p> <p>100: Select TCON [2] rising edge as toggle trigger signal (when toggle enable)</p> <p>101: Select TCON [2] rising edge as toggle trigger signal, then “AND” (when toggle enable)</p> <p>110: Select TCON [2] rising edge as toggle trigger signal, then “OR” (when toggle enable)</p> <p>111: Select reset(ODD=0) or set(ODD=1) TCON [3] by DVS, when toggle function enable</p> <hr/> <p>TCON [2] (Clock Toggle Function)[toggle function is inactive]</p> <p>00x: Normal TCON output</p> <p>010: Select DCLK/2 when TCON [2] is “0”</p> <p>011: Select DCLK/2 when TCON [2] is “1”</p> <p>100: Select DCLK/4 when TCON [2] is “0”</p>
--	---

		101: Select DCLK/4 when TCON [2] is “1” 110: Select DCLK/8 when TCON [2] is “0” 111: Select DCLK/8 when TCON [2] is “1” <hr/> TCON [1] xx0: Normal TCON output xx1: Reverse-Control Signal output <hr/> TCON [0] 00x: Normal TCON output 010: EVEN “REV” 18/24-bit function (“REV0” on TCON [0]) ODD “REV” 18/24-bit function (“REV1” on TCON [1]) 011: ALL “REV” 36/48-bit function (“REV” on TCON [0], can also on TCON [1]) 100: EVEN data Output Inversion Controlled by TCON [0] is “0” ODD data Output Inversion Controlled by TCON [1] is “0” 101: EVEN data Output Inversion Controlled by TCON [0] is “1” ODD data Output Inversion Controlled by TCON [1] is “1”
--	--	--

Dot masking
Address: 5F/67/6F/77 TC_DOT_MASKING_CTRL
Default: 00h

Bit	Mode	Function
7:3	R/W	Reserved to 0
2	R/W	Red Dot Masking Enable 0: Disable (Default) 1: Enable
1	R/W	Green Dot Masking Enable 0: Disable (Default) 1: Enable
0	R/W	Blue Dot Masking Enable 0: Disable (Default) 1: Enable

When applying dot masking, the timing setting for TCON will be

Real TCON_Mask_STA = TCON_STA+2

Real TCON_Mask_END = TCON_END +2

TCON [0] ~ TCON [13] Control Registers Address Map

Address	Data(# bits)	Default
0A,09,08	TCON [0]_VS_REG (11)	
0D,0C,0B	TCON [0]_HS_REG (11)	
0E	TCON [0]_CTRL_REG	00
0F	Reserved	
12,11,10	TCON [1]_VS_REG (11)	
15,14,13	TCON [1]_HS_REG (11)	
16	TCON [1]_CTRL_REG	00
17	Reserved	
1A,19,18	TCON [2]_VS_REG (11)	
1D,1C,1B	TCON [2]_HS_REG (11)	
1E	TCON [2]_CTRL_REG	00
1F	Reserved	
22,21,20	TCON [3]_VS_REG (11)	
25,24,23	TCON [3]_HS_REG (11)	
26	TCON [3]_CTRL_REG	00
27	Reserved	
2A,29,28	TCON [4]_VS_REG (11)	
2D,2C,2B	TCON [4]_HS_REG (11)	
2E	TCON [4]_CTRL_REG	00
2F	Reserved	
32,31,30	TCON [5]_VS_REG (11)	
35,34,33	TCON [5]_HS_REG (11)	
36	TCON [5]_CTRL_REG	00
37	Reserved	
3A,39,38	TCON [6]_VS_REG (11)	
3D,3C,3B	TCON [6]_HS_REG (11)	
3E	TCON [6]_CTRL_REG	00

3F	Reserved	
42,41,40	TCON [7]_VS_REG (11)	
45,44,43	TCON [7]_HS_REG (11)	
46	TCON [7]_CTRL_REG	00
47	Reserved	
4A,49,48	TCON [8]_VS_REG (11)	
4D,4C,4B	TCON [8]_HS_REG (11)	
4E	TCON [8]_CTRL_REG	00
4F	Reserved	
52,51,50	TCON [9]_VS_REG (11)	
55,54,53	TCON [9]_HS_REG (11)	
56	TCON [9]_CTRL_REG	00
57	Reserved	
5A,59,58	TCON [10]_VS_REG (11)	
5D,5C,5B	TCON [10]_HS_REG (11)	
5E	TCON [10]_CTRL_REG	00
5F	TCON [10]_CTRL_REG	
62,61,60	TCON [11]_VS_REG (11)	
65,64,63	TCON [11]_HS_REG (11)	
66	TCON [11]_CTRL_REG	00
67	TCON [11]_CTRL_REG	00
6A,69,68	TCON [12]_VS_REG (11)	
6D,6C,6B	TCON [12]_HS_REG (11)	
6E	TCON [12]_CTRL_REG	00
6F	TCON [12]_CTRL_REG	00
72,71,70	TCON [13]_VS_REG (11)	
75,74,73	TCON [13]_HS_REG (11)	
76	TCON [13]_CTRL_REG	00

77	TCON [13]_CTRL_REG	00

Control For LVDS

Address: 78 LVDS_CTRL0
Default: 00h

Bit	Mode	Function
7	R/W	Power up band-gap of LVDS/RSDS 0: Off (Default) 1: On
6	R/W	Power up LVDS PLL 0: Power down (Default) 1: Normal
5	R/W	Power up output even-port (all output modes) 0: Power down (Default) 1: Normal
4	R/W	Power up output odd-port (all output modes) 0: Power down (Default) 1: Normal
3:2	R/W	Watch Dog Model 00: Enable Watch Dog(Default) 01: Keep PLL VCO = 1V 1x: Disable Watch Dog
1	--	Reserved to 0
0	R	Watch Dog Control Flag (Write to clear) 0: Watch dog not active (Default) 1: Watch dog active, Reset PLL and set VCO = 1V

Address: 79 LVDS_CTRL1
Default: 04h

Bit	Mode	Function
7	R/W	Enable PLL test signal (output to pin 85) 0: Disable (Default) 1: Enable
6	R/W	Select PLL test signal 0: Fbak (Default) 1: Fin
5:3	R/W	STSTL [2:0]: select test attribute 000: High Impedance (Default) 001: VOCME

		010: VBG 011: IB100u(20K ohm to GND) 1xx: TSTPLL (50 ohm to VDD)
2:0	R/W	RSDS / LVDS Output Common Mode (Default: 100b)

Address: 7A **LVDS_CTRL2** Default: 16h

Bit	Mode	Function
7:6	--	Reserved to 0
5:4	R/W	SBGL [1:0]: Band-gap Voltage (~1.2V) 00: ~1.13V 01: ~1.20V (Default) 10: ~1.25V 11: ~1.35V
3:0	R/W	Bias Generator Adjust (0110)

Address: 7B **LVDS_CTRL3** Default: 12h

Bit	Mode	Function
7:6	--	Reserved to 0
5:3	R/W	SIL [2:0]: PLL charge pump current ($I=5\mu A+5\mu A*\text{code}$) (Default: 010)
2:1	R/W	SRL [1:0]: PLL resistor (Default: 01)
0	R/W	BMTS: Bit-Mapping Table Select 0: Table 1 (Default) 1: Table 2

TCLK+ 

LVDS	Bit 1	Bit 0	Bit 6	Bit 5	Bit 4	Bit 3	Bit 2	Bit 1	Bit 0	Bit 6	Bit 5
Even A	ER1	ER0	EG0	ER5	ER4	ER3	ER2	ER1	ER0	EG0	ER5
Even B	EG2	EG1	EB1	EB0	EG5	EG4	EG3	EG2	EG1	EB1	EB0
Even C	EB3	EB2	DEN	VS	HS	EB5	EB4	EB3	EB2	DEN*6	VS*5
Even D	ER7	ER6	RSV	EB7	EB6	EG7	EG6	ER7	ER6	RSV*7	EB7
Odd A	OR1	OR0	OG0	OR5	OR4	OR3	OR2	OR1	OR0	OG0	OR5
Odd B	OG2	OG1	OB1	OB0	OG5	OG4	OG3	OG2	OG1	OB1	OB0
Odd C	OB3	OB2	DEN	VS	HS	OB5	OB4	OB3	OB2	DEN*2	VS*1
Odd D	OR7	OR6	RSV	OB7	OB6	OG7	OG6	OR7	OR6	RSV*3	OB7

Bit-Mapping 6bit(5~0)+2bit(7~6)

TCLK+ 

LVDS	Bit 1	Bit 0	Bit 6	Bit 5	Bit 4	Bit 3	Bit 2	Bit 1	Bit 0	Bit 6	Bit 5
Even A	ER3	ER2	EG2	ER7	ER6	ER5	ER4	ER3	ER2	EG2	ER7
Even B	EG4	EG3	EB3	EB2	EG7	EG6	EG5	EG4	EG3	EB3	EB2
Even C	EB5	EB4	DEN	VS	HS	EB7	EB6	EB5	EB4	DEN*6	VS*5
Even D	ER1	ER0	RSV	EB1	EB0	EG1	EG0	ER1	ER0	RSV*7	EB1

Odd A	OR3	OR2	OG2	OR7	OR6	OR5	OR4	OR3	OR2	OG2	OR7
Odd B	OG4	OG3	OB3	OB2	OG7	OG6	OG5	OG4	OG3	OB3	OB2
Odd C	OB5	OB4	DEN	VS	HS	OB7	OB6	OB5	OB4	DEN*2	VS*1
Odd D	OR1	OR0	RSV	OB1	OB0	OG1	OG0	OR1	OR0	RSV*3	OB1

Bit-Mapping 6bit(7~2)+2bit(1~0)

Address: 7C
LVDS_CTRL4
Default: 80h

Bit	Mode	Function
7:6	R/W	E_RSV : even port reserve signal select 11: Always '1' 10: Always '0' 01: TCON [11] 00: PWM_0
5:4	R/W	E_DEN : even port data enable signal select 11: Always '1' 10: Always '0' 01: TCON [9] 00: DENA
3:2	R/W	E_VS : even port VS signal select 11: Always '1' 10: Always '0' 01: TCON [7] 00: DVS
1:0	R/W	E_HS : even port HS signal select 11: Always '1' 10: Always '0' 01: TCON [5] 00: DHS

Address: 7D
LVDS_CTRL5
Default: 80h

Bit	Mode	Function
7:6	R/W	O_RSV : odd port reserve signal select 11: Always '1' 10: Always '0' 01: TCON [13] 00: PWM_1
5:4	R/W	O_DEN : odd port data enable signal select 11: Always '1' 10: Always '0' 01: TCON [9] 00: DENA

3:2	R/W	O_VS : odd port VS signal select 11: Always '1' 10: Always '0' 01: TCON [7] 00: DVS
1:0	R/W	O_HS : odd port HS signal select 11: Always '1' 10: Always '0' 01: TCON [5] 00: DHS

Address: 7E Reserved

Realtek Confidential

Pin Share

Address: 8D
PIN_SHARE_CTRL0
Default: 00h

Bit	Mode	Function
7:6	R/W	Pin 3 (Power on latch for MCU location selection) 00: PWM0 01: TCON0 10: DVS 11: TCON3
5:4	R/W	Pin 4 (Power on latch for Xtal in Freq (M2PLL) selection) 00: PWM1 01: TCON1 10: DHS 11: TCON12
3:2	R/W	Pin 48 00: COUT (Default) 01: PWM1 10: DHS 11: TCON0
1:0	R/W	Pin 49 00: TCON7 (Default) 01: PWM2 10: DVS 11: TCON1

Address: 8E
PIN_SHARE_CTRL1
Default: 04h

Bit	Mode	Function
7	R/W	Pin 50/51 0: DDCSCL1/DDCSDA1 1: TCON4/TCON9
6	R/W	Pin 52/53 0: TCON13/TCON7 1: DCLK/DEN (Should set CR46[1]=1 first) i.e. Become SDIO0/SDIO1 if Power on latch for parallel port and MCU 52/53 location.
5:4	R/W	Pin 54 00: TCON11 01: DHS 10: BGRN0

		11: Rsv i.e. Become SDIO2 if Power on latch for parallel port and MCU 54 location.
3	R/W	Pin 55/56/57 0: TCON0/TCON12/TCON3 1: BGRN1/BRED0/BRED1 i.e. Become SDIO3/SCSB/SCLK if Power on latch for MCU 55-57 location.
2	R/W	Pin 122 (During reset period, the output should be M2PLL Out) 0: Normal function (Refer to CR8F[0]) 1: M2PLL
1	R/W	Pin 110 0: COUT (Default) 1: TCON13
0	--	Reserved to 0

Address: 8F
PIN_SHARE_CTRL2
Default: 00h

Bit	Mode	Function
7:6	R/W	Pin 111 00: V0 01: ARED1 10: PWM1 11: TCON2
5:4	R/W	Pin 112/113/114 00: V1/V2/V3 01: ARED0/AGRN1/AGRN0 10: PWM2/DDCSCL2/DDCSDA2 11: TCON10/TCON8/TCON5 i.e. Become SDIO0/SDIO1/SDIO2 if Power on latch for parallel port and MCU left location.
3	R/W	Pin 115/118/119 0: V4/V5/V6 1: TCON9/TCON7/TCON3 i.e. Become SDIO3/SCSB/SCLK if Power on latch for parallel port and MCU left location.
2:1	R/W	Pin 120/121 00: V7/VCLK 01: DCLK/DENA 10: DDCSDA2/DDCSCL2 11: TCON6/TCON4
0	R/W	Pin 122 (Normal function):

	0: PWM0
	1: TCON9

Realtek Confidential

Embedded OSD

Address: 90 **OSD_ADDR_MSB (OSD Address MSB 8-bit)**

Bit	Mode	Function
7:0	R/W	OSD MSB 8-bit address

Address: 91 **OSD_ADDR_LSB (OSD Address LSB 8-bit)**

Bit	Mode	Function
7:0	R/W	OSD LSB 8-bit address

Address: 92 **OSD_DATA_PORT (OSD Data Port)**

Bit	Mode	Function
7:0	W	Data port for embedded OSD access

Refer to the embedded OSD application note for the detailed.

Address: 93 **OSD_SCRAMBLE** **Default: 05**

Bit	Mode	Function
7	R/W	BIST Start 0: stop (Default) 1: start (auto clear to 0 when BIST finish)
6	R	BIST Result (Read this bit when CR05[7] return to stop condition) 0: fail (Default) 1: success
5	R	MCU writes data when OSD ON status (Queue 1 byte data) 0: MCU writes data to OSD but not to real position (There is one level buffer here) 1: MCU doesn't write data, or data has been written to real position
4	R	Double Buffer Write Status 0: double buffer write out is finish, or data write to double buffer is not ready, or no double buffer function. 1: after data write to dbuf and before dbuf write out, such that double buffer is busy.
3	--	Reserved to 0
2:0	R/W	Double buffer depth (Default=6) [Should set CR6C[0]=1] 000~101=>1~6

Address: 94 **OSD_TEST** **Default: 00**

Bit	Mode	Function
7:0	R/W	Testing Pattern

Reset Out and Panel Switch MOS Control

Address: 95 **POWER_ON_RESET_REGULATOR**
Default: 14

Bit	Mode	Function
7:6	R/W	Negative Threshold Value For Power on Reset 00:2.1V(Default) 01:2.4V 10:2.6V 11:2.8V
5:4	R/W	Negative Threshold Value For MCU Power Detecting 00: 1.2V 01: 1.3333V (Default) 10: 1.4666V 11: 1.6V
3	R/W	ADC Regulator Function 0: Enable (Default) 1: Disable
2:0	R/W	ADC Regulator Voltage Value[2:0] (supplying 200mA current) 000 to 111 => 2.2V to 1.5V (Default 101=>1.8V)

Address: 96 **EBD_REGLATOR_VOL**
Default: 88

Bit	Mode	Function
7:5	R/W	Digital Core Regulator Voltage Value[2:0] (supplying 200mA current) 000 to 111 => 2.2V to 1.5V (Default 100=>1.8V)
4:3	R/W	Band-gap Voltage Of Regulator Adjust Default: 01
2	R/W	Reserved to 0
1	R/W	Panel Switch (only for 3.3V) 0: switch off (Default) 1: switch on
0	--	Reserved to 0

Schmitt Trigger Control

Address: 97 **HS_SCHMITT_TRIGGE_CTRL**
Default: 41h

Bit	Mode	Function
7	R/W	HSYNC Schmitt Power Down (Only for Schmitt trigger new mode) 0: Power down (Default)

		1: Normal
6	R/W	Threshold Select (For new mode only) 0: Category 2 1: Category 1 (Default)
5	R/W	Schmitt Trigger Mode 0: Old mode (Default) 1: New mode
4	R/W	Threshold Voltage Fine Tune (For new mode only) 0: 0V (Default) 1: -0.1V
3:2	R/W	Positive Threshold Voltage
1:0	R/W	Negative Threshold Voltage

There are 3 mode of the HSYNC Schmitt trigger.

1. **Old mode 1:** original HSYNC Schmitt trigger.

bit[6:5]=00 $\Rightarrow V_t^+ = 1.41V, V_t^- = 1.0V$

2. **Old mode 2:** The easy HSYNC Schmitt trigger.

bit[6:5]=10 \Rightarrow

Bit[1:0]	V_t^+	V_t^-
01	2.68V	1.7V
10	2.3	1.3
11	2.0V	1.3V

3. **New mode:** Fully programmable Schmitt trigger.

The following table will determine the Schmitt Trigger positive and negative voltage:

bit[6]=1 Category 1				bit[6]=0 Category 2			
bit[3:2]	V_t^+	bit[1:0]	V_t^-	bit[3:2]	V_t^+	bit[1:0]	V_t^-
00	1.2V	00	0.2V	00	1.6V	00	0.2
01	1.4V	01	0.4V	01	1.7V	01	0.75
10	1.5V	10	0.7V	10	2.0V	10	2.0
11	1.7V	11	1.0V	11	2.1V	11	2.1

After we get the threshold voltage by the table, we still can fine tune it:

Final Positive Threshold Voltage = $V_t^+ - 0.1 * \text{bit}[4]$

Final Negative Threshold Voltage = $V_t^- - 0.1 * \text{bit}[4]$

Phase-Lock-Loop (PLL)

DDS Setting for ADC

Address: 98 PLL_DIV_CTRL Default: 04h

Bit	Mode	Function
7	R/W	PFD Selection 0: New PFD fine (Default) 1: New PFD coarse (the resolution will be 1/2 of the PFD fine mode)
6	R/W	DDS Tracking Edge 0: HS positive edge (Default) 1: HS negative edge
5	R/W	DDS Reset Enable 0: Normal function (Default) 1: DDS circuit's reset will be asserted, for test only
4	R/W	Test Mode: (for production test) 0: Normal (Default) 1: Test Mode
3	R/W	HS output synchronized by 0: phase 32 1: phase 0 (Default)
2:1	R/W	Delay Compensation Mode 00: Mode 0 01: Mode 1 10: Mode 2 (Default) 11: Mode 3
0	R/W	Clock select for DIV 0: phase 0 (phase-0 of PLL2) (Default) 1: internal CLK (Fav)

Address: 99 I_CODE_L Default: 47h

Bit	Mode	Function
7:3	R/W	Old/New mode: I_Code [9:5] (Default: 01000)
2	R/W	Old mode: I_Code [4] (Default=1) New mode: I-code control mechanism 0: new linear mode, $PE*(2+NEW_I[13])$ 1: old mode, $P\text{-code} = I[17:0] - 1$ (Default)
1:0	R/W	Old mode: I_Code [3:2] (Default: 11) New mode: P-code protection mode 00 => No protection 01 => 1 bit protection 10 => 2 bits protection

		11 => 3 bits protection (Default)
Address: 9A		I_CODE_M Default: 00h
Bit	Mode	Function
7:6	R/W	Old mode : I_Code [15:14] (Default: 00)
5	R/W	Old mode : I_code [13] (Default:0) New mode : I_code calibrated setting
4	R/W	Old mode : I_Code [12] (Default:0) New mode : P_code calibrated setting
3	R/W	Old mode : I_Code [11]
2	R/W	I_Code [10] or PFD type selection 0: Old PFD (Default) 1: New PFD
1	R/W	Old mode : I_Code [1] (Default: 0) New mode : P-code mapping curve 0: choose the new P-code mapping curve $(PE*2+NEW_I[12])*2^{NEW_P+2}$ 1: choose the old P-code mapping curve
0	R/W	Old mode: I_Code [0] (Default: 0) New mode: I-code multiplication factor 0: choose the new I-code multiplication factor = $2^{(NEW_I[9:5]+2)}$ 1: choose the old I-code multiplication factor

I CONTROL = (I-CODE control mechanism)*(I-code multiplication factor)

Address: 9B		P_CODE Default: 18h
Bit	Mode	Function
7	R/W	Phase Swallow Down Enable 0: Swallow Up (Default) 1: Swallow Down
6:5	R/W	I_Code[17:16] Default: 00b
4:0	R/W	P_Code[4:0] Default: 18h

Address: 9C **PFD_CALIBRATED_RESULTS** **Default: 8'b 00xxxxxx**

Bit	Mode	Function
7	--	Reserved to 0
6	R/W	PFD Calibration Enable Overwrite 0 to 1 return a new PFD calibrated results.
5:0	R	PFD Calibrated Results[5:0]

Address: 9D **PE_MEASURE** **Default: 00h**

Bit	Mode	Function
7:6	--	Reserved to 0

5	R/W	PE Measure Enable 0: Disable (Default) 1: Start PE Measurement, clear after finish.
4:0	R	PE Value Result [4:0]

Address: 9E **PE_MAX_MEASURE** **Default: 00h**

Bit	Mode	Function
7	---	Reserved to 0
6	R/W	PE Max. Measure Enable 0: Disable (Default) 1: Start PE Max. Measurement
5	R/W	PE Max. Measure Clear 0: clear after finish (Default) 1: write '1' to clear PE Max. Value
4:0	R	PE Max Value[4:0]

Address: 9F **FAST_PLL_CTRL** **Default: 00h**

Bit	Mode	Function
7	--	Reserved to 0
6	R/W	Enable APLL Setting 0: Disable (Default) 1: Enable (Auto clear when finished) When CR9F[5] enabled, enable this bit will write PLL2M/N, PLLDIV and DDS SUM_I at the end of input vertical data enable
5	R/W	Enable Fast PLL Mechanism 0: Disable (Default) 1: Enable
4	--	Reserved to 0
3	R/W	DDS I_SUM Setting Updated Enable 0: Disable (Default) 1: Enable (Auto clear when finished)
2	R/W	Measure I_SUM 0: Disable 1: Enable (Auto clear after finish)
1	R/W	Enable Port A0 0: Disable Port A0 Access 1: Enable Port A0 Access When this bit is 0, port address will be reset to 00, and will auto increase when read or write

0	R/W	Select I_SUM for Read 1: Select SUM_I_NOW[31:0] for read 0: Select SUM_I_PRE[31:0] for read
---	-----	--

Address: A0 **FAST_PLL_ISUM** **Default: 80h**

Bit	Mode	Function
7:0	R/W	I_SUM (Auto Increase) 1 st I_SUM[31:24] 2 nd I_SUM[23:16] 3 rd I_SUM[15:8] 4 th I_SUM[7:0]

Realtek Confidential

ADC PLL1
Address: A1 **PLL1_M (M Parameter Register)** **Default: 0Fh**

Bit	Mode	Function
7:0	R/W	PLL1M[7:0] (PLL1_DPM value – 2)

Address: A2 **PLL1_N (N Parameter Register)** **Default: 80h**

Bit	Mode	Function
7	R/W	PLL1PWDN (PLL1 Power Down) 0: Normal Run 1: Power Down (Default)
6:4	---	Reserved to 0
3:0	R/W	PLL1N[3:0] (PLL1_DPN value – 2)

I PLL1_N modify to only 4-bit.

I Assume PLL1_M=0x0B, P1M=0x0B+2=13; PLL1_N=0x03, P1N=0x03+2=5; F_IN = 24.576MHz. F_PLL1 = F_IN x P1M / P1N = 24.576 x 13 / 5 = 63.8976MHz

 I If the target frequency is F_ADC, the constraint of F_PLL1 is $(15/16)*F_ADC < F_PLL1 < F_ADC$
Address: A3 **PLL1_CRNT (PLL1 Current/Resistor Register)** **Default: 33h**

Bit	Mode	Function
7	R/W	Reserved to 0
6:4	R/W	PLL1VR[2:0] (PLL1 Loop Filter Resistor Control) 000: 20K 001: 21K 010: 22K 011: 23K (Default) 100: 24K 101: 25K 110: 26K 111: 27K
3:0	R/W	PLL1SI[3:0] (PLL1 Charger Pump Current) (Default: 0011b) Icp = 2.5uA+2.5uA*bit[0]+5uA*bit[1]+10uA*bit[2]+20uA*bit[3]

I Keep Icp/PLL1_DPM constant

Address: A4 **PLL1_WD (PLL1 Watch Dog Register)** **Default: 0Eh**

Bit	Mode	Function
7	R	PLL1STATUS (PLL1 WD Status) 0: Normal (Default) 1: Abnormal
6	R/W	PLL1WDRST (PLL1 WD Reset) 0: Normal (Default) 1: Reset

5	R/W	PLL1WDSET (PLL1 WD Set) 0: Normal (Default) 1: Set
4:3	R/W	PLL1WDVSET[1:0] (PLL1 WD Voltage Set) 00: 2.46V 01: 1.92V(Default) 10: 1.36V 11: 1.00V
2	R/W	PLL1UPDN (PLL1 Frequency Tuning Up/Down) 0: Freq Down 1: Freq Up (Default)
1	R/W	PLL1MSBSTOP (PLL1 Frequency Tuning Enable) 0: Disable 1: Enable (Default)
0	---	Reserved to 0

ADC PLL2
Address: A5 **PLL2_M (M Parameter Register)** **Default: 3Eh**

Bit	Mode	Function
7:0	R/W	PLL2_M[7:0] (PLL2_DPM value – 2) (Default 3E)

Address: A6 **PLL2_N (N Parameter Register)** **Default: 3Dh**

Bit	Mode	Function
7:0	R/W	PLL2_N[7:0] (PLL2_DPN value – 2) (Default 3D)

I Assume PLL2_M=0x0A, P2M=0x0A+2=12; PLL2_N=0x04, P2N=0x04+2=6; F_IN =65 MHz .

 I $F_{PLL2} = F_{IN} \times P2M \times 2 / P2N / 2 = 65 \times 12 \times 2 / 6 / 2 = 130 \text{ MHz}$

 I The constraint of F_PLL2 is that $P2N = (int)(F_{IN} / 10)$
Address: A7 **PLL2_CRNT (PLL2 Current/Resistor Control)** **Default: 6Fh**

Bit	Mode	Function
7:5	R/W	PLL2VR[2:0] (PLL2 Loop Filter Resister Control) 000: 15K 001: 16K 010: 17K 011: 18K 100: 19K 101: 20K 110: 21K 111: 22K
4:0	R/W	PLL2SI[4:0] (PLL2 Charger Pump Current Ich) $I_{cp} = 2.5\mu\text{A} + 2.5\mu\text{A} * \text{bit}[0] + 5\mu\text{A} * \text{bit}[1] + 10\mu\text{A} * \text{bit}[2] + 20\mu\text{A} * \text{bit}[3] + 30\mu\text{A} * \text{bit}[4]$

1 Keep Icp/DPM constant
Address: A8 PLL2_WD (PLL2 Watch Dog Register)
Default: 09h

Bit	Mode	Function
7	R	PLL2STATUS (PLL2 WD Status) 0: Normal (Default) 1: Abnormal
6	R/W	PLL2WDRST (PLL2 WD Reset) 0: Normal (Default) 1: Reset
5	R/W	PLL2WDSET (PLL2 WD Set) 0: Normal (Default) 1: Set
4:3	R/W	PLL2WDVSET[1:0] (PLL2 WD Voltage Set) 00: 2.46V 01: 1.92V(Default) 10: 1.36V 11: 1.00V
2:1	R/W	ADCKMODE[1:0] (ADC Input Clock Select Mode) 00 : Single Clock Mode (Default) 01 : Single Inverse-Clock Mode 10 : External Clock Mode 11 : Dual Clock Mode (1x and 2x Clock)
0	R/W	PLL2PWDN (PLL2 Power Down) 0: Normal Run 1: Power Down (Default)

Address: A9
PLLDIV_H
Default: 05h

Bit	Mode	Function
7	---	Reserved to 0
6	R/W	Phase_Select_Method 0: Manual (Default) 1: Look-Up-Table
5	R/W	PLL2PH0PATH 0: Short Path (Default) 1: Long Path (Compensate PLL_ADC path delay)
4	R/W	PLL2D2 0:ADC CLK=1/2 VCO CLK (Default) 1:ADC CLK=1/4 VCO CLK

3:0	R/W	PLL Divider Ratio Control. High-Byte [11:8]. (Default: 5h)
------------	------------	---

Address: AA **PLLDIV_L** **Default: 3Fh**

Bit	Mode	Function
7:0	R/W	PLL Divider Ratio Control. Low-Byte [7:0]. PLLDIV should be double buffered when PLLDIV_LO changes and IDEN_STOP occurs.

- | This register determines the **horizontal total** pixels. PLL derives the sampling clock and data output clock (DCLK) from input HSYNC. *The real operation Divider Ratio = PLLDIV+1*
- | The default value of PLLDIV is 053Fh(=1343, VESA timing standard, 1024x768 60Hz, Horizontal time).
- | CRA9 & AA will be written in when CR AA is written.

Address: AB **PLLPHASE_CTRL0 (Select Phase to A/D)** **Default: 30h**

Bit	Mode	Function
7	R/W	PLL2D2X control (Default=0)
6	R/W	PLL2D2Y control (Default=0)
5	R/W	PLL2X (PLL2 X Phase control) (Default=1)
4	R/W	PLL2Y (PLL2 X Phase control) (Default=1)
3:0	R/W	PLL2SCK[4:1] (PLL2 32 Phase Pre-Select Control) (Default=0h)

Address: AC **PLLPHASE_CTRL1 (Select Phase to A/D)** **Default: 00h**

Bit	Mode	Function
7	R/W	PLL2SCK[0] (PLL2 32 Phase Pre-Select Control) (Default=0)
6	R/W	MSB of 128 phase (Only for ADC CLK=1/4 VCO CLK) (Default=0)
5:0	R/W	Phase Select the index of Look-Up-Table[5:0] (Default=0)

- | When Phase_Select_Method=1, Phase is selected by CR[AC]-Bit[6:0].
- | When Phase_Select_Method=0, PLL2D2X, PLL2D2Y, PLL2X, PLL2Y, PLL2SCLK[4:0] Should be double buffered when PLL2SCK[0] is updated

Address: AD **PLL2_PHASE_INTERPOLATION** **Default: 50h**

Bit	Mode	Function
7:6	R/W	PLL2 Phase Interpolation Control Load (Default: 01)
5:3	R/W	PLL2 Phase Interpolation Control Source (Default: 010)
2:1	R/W	PLL2 Add Phase Delay 00: Original phase selected by X,Y and 16-phase pre-select 01-11: Add 1-3 delay to Original phase selected by X,Y and 32-phase pre-select
0	R/W	DPLL Clock to SSCG 0: DPLLVCO/4 (Default) 1: (DPLLVCO+Phase_Swallow)/4

Phase	[XY ^^^^^]	Phase	[XY ^^^^^]	Phase	[XY ^^^^^]	Phase	[XY ^^^^^]
0	[11 00000]	16	[01 10000]	32	[10 00000]	48	[00 10000]
1	[11 00001]	17	[01 10001]	33	[10 00001]	49	[00 10001]
2	[11 00010]	18	[01 10010]	34	[10 00010]	50	[00 10010]
3	[11 00011]	19	[01 10011]	35	[10 00011]	51	[00 10011]
4	[11 00100]	20	[01 10100]	36	[10 00100]	52	[00 10100]
5	[11 00101]	21	[00 10101]	37	[10 00101]	53	[00 10101]
6	[11 00110]	22	[00 10110]	38	[10 00110]	54	[00 10110]
7	[11 00111]	23	[01 10111]	39	[10 00111]	55	[00 10111]
8	[11 01000]	24	[01 11000]	40	[10 01000]	56	[00 11000]
9	[11 01001]	25	[01 11001]	41	[10 01001]	57	[00 11001]
10	[01 01010]	26	[10 11010]	42	[10 01010]	58	[11 11010]
11	[01 01011]	27	[10 11011]	43	[10 01011]	59	[11 11011]
12	[01 01100]	28	[10 11100]	44	[00 01100]	60	[11 11100]
13	[01 01101]	29	[10 11101]	45	[00 01101]	61	[11 11101]
14	[01 01110]	30	[10 11110]	46	[00 01110]	62	[11 11110]
15	[01 01111]	31	[10 11111]	47	[00 01111]	63	[11 11111]

DISPLAY PLL
Address: AE DPLL_M (DPLL M Divider Register) Default: 2Ch

Bit	Mode	Function
7:0	R/W	DPLL_M[7:0] (DPLL DPM value – 2)

Address: AF DPLL_N (DPLL N Divider Register) Default: 83h

Bit	Mode	Function
7	R/W	DPLLPWDN (DPLL Power Down) 0: Normal Run 1: Power Down (Default)
6	R/W	DPLLFREEZE (DPLL Output Freeze) 0: Normal (Default) 1: Freeze
5:4	R/W	DPLLO[1:0] (DPLL Output Divider) 00: Div1 (Default) 01: Div2 10: Div4 11: Div8
3:0	R/W	DPLL_N[7:0] (DPLL DPN value – 2) (Default: 3h)

! Assume DPLL_M=7Dh, DPM=7Dh+2=127; DPLL_N=0Ah, DPN=0Ah+2=12; Divider=1/4, F_IN = 24.576MHz.
F_DPLL = F_IN*DPM / (DPN *Divider) = 24.576*127 / (12*4) = 65.024MHz.

! If LPF_Mode = 1, suppose DPM=110, DPN = 12, Icp = [000100] = 6.25uA, DPLL=225MHz, then DPM / Icp

=17.6. Please keep the ratio as constant.

- I If LPF_Mode = 0, suppose DPM=46, DPN = 5, Icp = [101010] =27.5uA, DPLL=226MHz, then DPM / Icp = 1.67.
Please keep the ratio as constant.

Address: B0 **DPLL_CRNT (DPLL Current/Resistor Register)** **Default: 6Ah**

Bit	Mode	Function
7:6	R/W	DPLLVR[1:0] (DPLL Loop Filter Resistor Control) 00: 16K (LPF Mode = 0), 46K (LPF Mode = 1) 01: 18K (LPF Mode = 0), 53K (LPF Mode = 1) (Default) 10: 20K (LPF Mode = 0), 60K (LPF Mode = 1) 11: 22K (LPF Mode = 0), 67K (LPF Mode = 1)
5:0	R/W	DPLLSI[5:0] (DPLL Charger Pump Current IchDpll) (Default: 101010b) $I = (2.5\mu A + D[0] * 2.5\mu A + D[1] * 5\mu A + D[2] * 10\mu A + D[3] * 20\mu A + D[4] * 30\mu A)$ $I_{cp} = I * (1 + D[5]) / 2$

- I Keep Icp/DPM constant

Address: B1 **DPLL_WD (Watch Dog Register)** **Default: 0Fh**

Bit	Mode	Function
7	R	DPLLSTATUS (DPLL WD Status) 0: Normal 1: Abnormal
6	R/W	DPLLWDRST (DPLL WD Reset) 0: Normal (Default) 1: Reset
5	R/W	DPLLWDSET (DPLL WD Set) 0: Normal (Default) 1: Set
4:3	R/W	DPLLWDVSET[1:0] (DPLL WD Voltage Set) 00: 0.80V 01: 1.34V (Default) 10: 1.88V 11: 2.42V
2	R/W	DPLLUPDN (DPLL Frequency Tuning Up/Down) 0: Freq Up 1: Freq Down (Default)
1	R/W	DPLLSTOP (DPLL Frequency Tuning Enable) 0: Disable 1: Enable (Default) Turn on before CRBB[0].
0	R/W	DPLLLPFMODE (DPLL LPF Mode)

	0: LPFMode=0 \Rightarrow DPN \leq 5 Icp= 27.5uA /DPM=46/DPN=5
	1: LPFMode=1 \Rightarrow 16 \geq DPN \geq 5 Icp= 6.25uA/DPM=110/DPN=12 (Default)

MULTIPLY PLL FOR INPUT CYRSTAL
Address: B2 MULTI_PLL_CTRL0 Default: E2h

Bit	Mode	Function
7:4	R/W	M2PLL M Code[3:0]-2 (DPM) Default=16 \Rightarrow 1110
3	R/W	M2PLL Power Down 0: Normal Run (Default) 1: Power Down
2	R/W	M2PLL Output Freeze 0: Normal (Default) 1: Freeze i.e.: when output is frozen, the internal PLL is still operating
1	R/W	M2PLL N Code 0: N=1 1: N=2 (Default)
0	R	M2PLL WD Status 0: Normal 1: Abnormal

Address: B3 MULTI_PLL_CTRL1 Default: 94h

Bit	Mode	Function
7:6	R/W	M2PLL Loop Filter Resistor Control 00: 15K 01: 18K 10: 21K(Default) 11: 24K
5:4	R/W	M2PLL Loop Filter Charge Current Control(Default:01) Icp = 5uA+5uA*D[4]+10uA*D[5] i.e.: Keep Icp/DPM constant
3:2	R/W	M2PLL WD Voltage 00: 0.80V 01: 1.0V (Default) 10: 1.2V 11: 1.4V
1	R/W	M2PLL_WDRST 0: Normal (Default)

		1: Reset (M2PLL Function as a Normal PLL, regardless WD)
0	R/W	M2PLL_WDSET 0: Normal (Default) 1: Set (Free Run by WD asserts VCO Voltage)

PLL TEST
Address: B4
PLL_TEST (PIN3)
Default: 19h

Bit	Mode	Function
7:6	--	Reserved to 0
5	R/W	PLL_TP1_FAST (PLL_TestPin1 TTL Output Driving) 0: Slow (Default) 1: Fast
4:3	R/W	PLL_TP1_MODE[1:0] (PLL_TestPin1 I/O Mode Select) 00: Analog In/Out 01: Open drain Output 10: Digital TTL Output 11: Digital TTL Input (3V) → Power on latch to determine MCU direction (Default)
2:0	R/W	PLL_TP1_MUX[2:0] (PLL_TestPin1 Output Signal Select) 000: DPLL Clock 001: PLL1 Status 010: FAV clock(From PLL1) 011: PLL2 Status 100: HSOUT 101: ADC clock (from PLL2) 110: EMPTY FLAG(DDC/CI BUFFER) 111: Normal Operation Usage (Refer to CR8D)

PLL_TEST (PIN4)
Default: 19h

Bit	Mode	Function
7	--	Reserved to 0
6	R/W	Select the external clock source instead of DPLL clock for MP test (Digital TTL input) 0: Disable 1: Enable
5	R/W	PLL_TP2_FAST (PLL_TestPin1 TTL Output Driving) 0: Slow 1: Fast
4:3	R/W	PLL_TP2_MODE[1:0] (PLL_Test Pin2 I/O Mode Select) 00: Analog In/Out 01: Open drain Output

		10: Digital TTL Output 11: Digital TTL Input (3V) → Power on latch to determine Xtal out frequency (Default)
2:0	R/W	PLL_TP2_MUX[2:0] (PLL_TestPin2 Output Signal Select) 000: PLL1 Clock 001: DPLL Status 010: PLL2 Phase0 clock 011: M2PLL clock 100: HSFB 101: Normal Operation Usage (Refer to CR8D) 110: FULL FLAG(DDC/CI BUFFER) 111: RSV

When CR[B5]-Bit[7] = 0, CR[B4] controls PLL_TEST1(pin3).

When CR[B5]-Bit[7] = 1, CR[B4] controls PLL_TEST2(pin4).

DCLK Spread Spectrum

Address: B5 **DCLK_FINE_TUNE_OFFSET_MSB**

Default: 00h

Bit	Mode	Function
7	R/W	Setting for PLL1_TP1 or PLL2_TP2 0: PLL_TP1 (Default) 1: PLL_TP2
6	R/W	DPLL Reference Frequency Select 0: Original Crystal Clock (Default) 1: Clock After M2PLL
5	R/W	Only Even / Odd Field Mode Enable 0: Disable (Default) 1: Enable
4	R/W	Even / Odd Field Select 0: Even (Default) 1: Odd
3:0	R/W	DCLK Offset [11:8] in Fixed Last Line DVTOTAL & DHTOTAL

Address: B6 **DCLK_FINE_TUNE_OFFSET_LSB**

Default: 00h

Bit	Mode	Function
7:0	R/W	DCLK Offset [7:0] in Fixed Last Line DVTOTAL & DHTOTAL

Address: B7 **SPREAD_SPECTRUM**

Default: 00h

Bit	Mode	Function
7:4	R/W	DCLK Spreading range (0.0~7.5%) The bigger setting, the spreading range will bigger, but not uniform

3	R/W	Spread Spectrum FMDIV (SSP_FMDIV)/(0) 0: 33K 1: 66K
2	R/W	Spread Spectrum Setting Ready for Writing (Auto Clear) 0: Not ready 1: Ready to write
1:0	R/W	Frequency Synthesis Select (F & F-N*dF) 00~11: N=1~4

! The following control register will be written after CRB7[2] is applied, be ready the following bits before applying CRB7[2]

1. DCLK spreading range (CRB7[7:4])
2. Spread spectrum FMDIV (CRB7[3])
3. DCLK offset setting (CRB5[3:0] & CRB6)
4. Frequency synthesis select (CRB7[1:0])

Address: B8 **FIXED_LAST_LINE_MSB**

Bit	Mode	Function
6:4	R/W	Fixed Last Line Length [11:8]
3:0	R/W	Fixed DVTOTAL [11:8]

Address: B9 **FIXED_LAST_LINE_DVTOTAL_LSB**

Bit	Mode	Function
7:0	R/W	Fixed DVTOTAL [7:0]

Address: BA **FIXED_LAST_LINE_LENGTH_LSB**

Bit	Mode	Function
7:0	R/W	Fixed Last Line Length [7:0]

! Fixed last line value can't be zero, and can't smaller than DH_Sync width.

Address: BB **FIXED_LAST_LINE_CTRL**

Default: 00h

Bit	Mode	Function
7:4	--	Reserved to 0
3	R/W	Enable New Design Function in Fixed Last Line Mode 0: Disable (Default) 1: Enable
2	R/W	DDS Spread Spectrum Test Enable 0: Disable (Default) 1: Enable
1	R/W	Enable the Fixed DVTOTAL & Last Line DHTOTAL Function 0: Disable (Default) 1: Enable
0	R/W	Enable DDS Spread Spectrum Output Function 0: Disable (Default)

	1: Enable
--	-----------

Procedure:

- I First, we have set M/N code and then we need to tune DCLK OFFSET to achieve frame-sync, every step of offset frequency is $DCLK/2^{15}$.
- I When we finished the frame-sync, we turn on CR BB[1] to let the system running in to free-run mode, at this time, the CRB8,CRB9,CRBA are the reference DV and DH total and Fixed last Line Length.
- I But the free-run mode DVS' should be close to frame-sync mode DVS to achieve pseudo-frame-sync(actually, it is free run mode now)
- I Then we use CRB7 [1:0] (F-N*dF) to keep DVS' and DVS very closely to achieve pseudo-frame-sync.

Notice:

- I In RTD2523B, when all the setting above is ready, then we open spread spectrum function, the DCLK OFFSET will shift, please keep the DCLK OFFSET keeps steady when we open spread spectrum function.
- I In Real free-run mode, the DV_TOTAL refers to CR32/CR33, and in Fixed-Last-Line mode, the free-run timing DV_TOTAL refers to CRB8/CRB9, at this time CR35/36 serve for Vsync-timeout watch dog reference.

Realtek Confidential

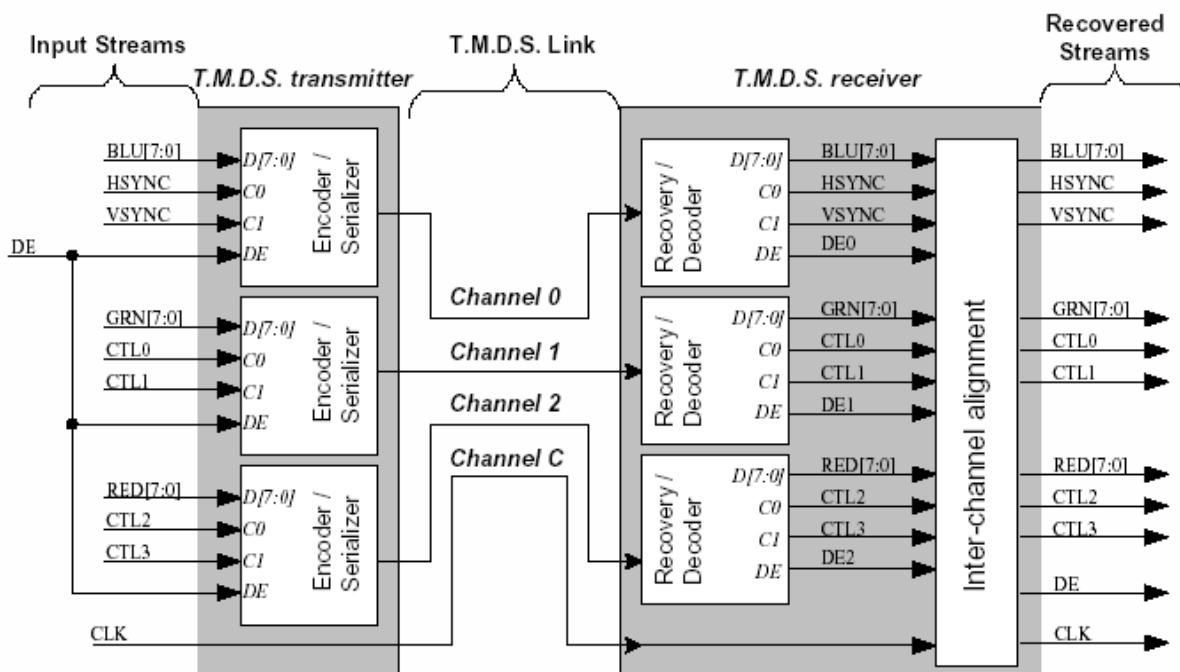
Embedded T.M.D.S (Optional)

Address: BC T.M.D.S. MEASURE_SELECT Default: 00h

Bit	Mode	Function
7	--	Reserved to 0
6:4	R/W	Measure times(exponential of 2) 000: 1 001: 2 010: 4 011: 8 100: 16 101: Not available 110: Not available 111: Not available
3:0	R/W	Numbers of Clock Period, measurement duration (where clock frequency is 12Khz) 0000: 16 0001: 1 0010: 2 0011: 3

	 1111: 15
--	--	-------------------

This function will do bit [6:4] times, each time lasts for bit [3:0]/12 ms.

Address: BD **TMDS_MEAS_RESULT0** **Default: 0000011xb**

Bit	Mode	Function
7	R/W	Transition measurement 0: Stop measure, Cleared after finish (Default) 1: Start measure
6:5	R/W	Measure Result Select 00: AVE Value (Default) 01: Max Value 10: Min Value
4:3	R/W	Measure Select 00: Measure Hsync transition times before error correction. 01: Measure Hsync transition times after error correction. 10: Measure Data Enable transition times before error correction. 11: Measure Data Enable transition times after error correction.
2	R/W	Clock DC Offset 0: Disable 1: Enable DC Offset Compensation
1	R/W	R/G/B DC Offset 0: Disable 1: Enable DC Offset Compensation
0	--	Reserved

Address: BE **TMDS_MEAS_RESULT1**

Bit	Mode	Function
7	---	Reserved
6:0	R	Value of measure result[6:0] (Item refer to CRBD[6:5])

Address: BF **TMDS_CTRL**

Bit	Mode	Function
7	R	B channel detect (DE low 128 clock)(write clear) 0: no 1: yes
6	R	G channel detect (DE low 128 clock)(write clear) 0: no 1: yes

5	R	R channel detect (DE low 128 clock)(write clear) 0: no 1: yes
4	R	Hsync occur(write clear) 0: no 1: yes
3	R	Vsync occur(write clear) 0: no 1: yes
2	R	Authst (Means bksv of RTD pass Tx authorization, Tx is ready to do HDCP transaction)
1	R	Authkm (Means RTD finish computing KM, ri)
0	R	Authdone (Means TX admitted ri value, start to do HDCP transmission)

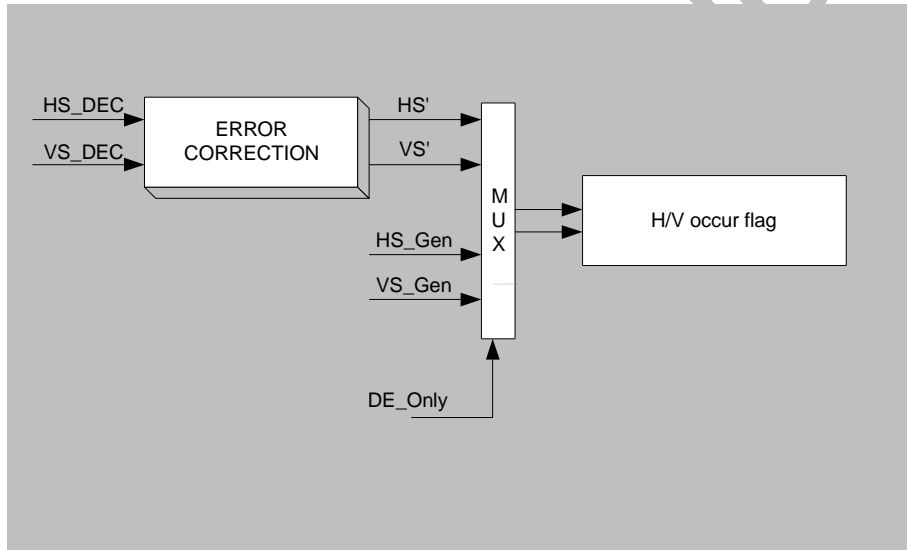

Address: C0 CRC_OUTPUT_BYTE_2

Bit	Mode	Function
7:0	R/W	1 st read=> Output CRC-24 bit 23~16 2 nd read=> Output CRC-24 bit 15~8 3 rd read=> Out put CRC-24 bit 7~0

I The read pointer should be reset when 1. CRC Output Byte is written 2. CRC Check starts.

I The read back CRC value address should be auto-increase, the sequence is shown above

Address: C1 TMDS_OUTPUT_CTRL

Default: 04h

Bit	Mode	Function
7	R/W	Auto Output Enable 0: Disable (Default) 1: Enable

6	R/W	TMDS R Channel Output Enable (can be manually controlled when CRC1[7]=0) 0: Disable (Default) 1: Enable
5	R/W	TMDS G Channel Output Enable (can be manually controlled when CRC1[7]=0) 0: Disable (Default) 1: Enable
4	R/W	TMDS B Channel Output Enable (can be manually controlled when CRC1[7]=0) 0: Disable (Default) 1: Enable
3	R/W	OCLK Enable 0: Disable 1: Enable (Default)
2	R/W	OCLK Invert enable 0: Normal (Default) 1: Enable
1	R/W	OCLK divide 2 0: Disable (Default) 1: Enable
0	R/W	CLK25XINV 0: No Invert (Default) 1: Invert

Address: C2 POWER_ON_OFF_CTRL
Default: 20h

Bit	Mode	Function
7	R/W	DE-only: Generate VS/HS from DE signal 0: Disable (Default) 1: Enable
6	R/W	B/R channel swap 0: No swap (Default) 1: Swap
5	R/W	Input Channel control by auto function 0: Manual 1: Auto (Default)
4	R/W	Enable Clock channel: turn on clock channel PLL (can be manually controlled when CRC2[5]=0) 0: Disable (Default) 1: Enable
3	R/W	Enable Red input port (For manual use, cut off 50ohm internal resistor)

		(can be manually controlled when CRC2[5]=0) 0: Disable (Default) 1: Enable
2	R/W	Enable Green input port (For manual use, cut off 50ohm internal resistor) (can be manually controlled when CRC2[5]=0) 0: Disable (Default) 1: Enable
1	R/W	Enable Blue input port (For manual use, cut off 50ohm internal resistor) (can be manually controlled when CRC2[5]=0) 0: Disable (Default) 1: Enable
0	R/W	CRC check 0: Stop 1: Start CRC check during the next full frame and clear after finish (CRC value in CRC1)

Address: C3 **ANALOG_COMMON_CTRL0** **Default: 83h**

Bit	Mode	Function
7:4	R	RESL<3:0> Z0 value 0000: max. 1111: min. Read back Z0 value when calibration is finished.
3:0	R/W	SPADL<3:0>: Selection TSTPAD mode for analog test 0000: 40u 0001: select TMDS test signal (Please reference CRC5) 0010: D2PL(For PWM0/TCON2) (pin 5) x011: P2DL (Pad to Digital, Digital input 3.3V) (Default) power on latch x1xx: HZ 1000: A2P33V 1001: D2P33V in open drain mode 1010: D2P33V in TTL mode

Address: C4 **ANALOG_COMMON_CTRL1** **Default: 00h**

Bit	Mode	Function
7:6	R/W	TMDS_TEST Normal Output Selection 00: PWM0 01: TCON2 10: IRQ# 11: Rsv
5	R/W	ENTSTL : enable internal test signal list below

		0: off 1: on																																																								
4:0	R/W	SPADTSTL<4:0>: select test signal (SPADL<3:0>=0001b)																																																								
		<table border="1"> <tr> <td>00x00</td> <td>CLKPLLPOWL</td> <td>10010</td> <td>Fin in green port</td> </tr> <tr> <td>00x01</td> <td>LPRST in clk port</td> <td>10011</td> <td>Fbak in green port</td> </tr> <tr> <td>00x10</td> <td>Fin in clk port</td> <td>10100</td> <td>Ck2.5x sampling clk in green port</td> </tr> <tr> <td>00x11</td> <td>Fbak in clk port</td> <td>10101</td> <td>Ck2.5x in green port</td> </tr> <tr> <td>01000</td> <td>BLUPOWL</td> <td>10110</td> <td>Ck1.0x in green port</td> </tr> <tr> <td>01001</td> <td>LPRST in blue port</td> <td>10111</td> <td>Ck0.5x in green port</td> </tr> <tr> <td>01010</td> <td>Fin in blue port</td> <td>11000</td> <td>REDPOWL</td> </tr> <tr> <td>01011</td> <td>Fbak in blue port</td> <td>11001</td> <td>LPRST in red port</td> </tr> <tr> <td>01100</td> <td>Ck2.5x sampling clk in blue</td> <td>11010</td> <td>Fin in red port</td> </tr> <tr> <td>01101</td> <td>Ck2.5x in blue port</td> <td>11011</td> <td>Fbak in red port</td> </tr> <tr> <td>01110</td> <td>Ck1.0x in blue port</td> <td>11100</td> <td>Ck2.5x sampling clk in red port</td> </tr> <tr> <td>01111</td> <td>Ck0.5x in blue port</td> <td>11101</td> <td>Ck2.5x in red port</td> </tr> <tr> <td>10000</td> <td>GRNPOWL</td> <td>11110</td> <td>Ck1.0x in red port</td> </tr> <tr> <td>10001</td> <td>LPRST in green port</td> <td>11111</td> <td>Ck0.5x in red port</td> </tr> </table>	00x00	CLKPLLPOWL	10010	Fin in green port	00x01	LPRST in clk port	10011	Fbak in green port	00x10	Fin in clk port	10100	Ck2.5x sampling clk in green port	00x11	Fbak in clk port	10101	Ck2.5x in green port	01000	BLUPOWL	10110	Ck1.0x in green port	01001	LPRST in blue port	10111	Ck0.5x in green port	01010	Fin in blue port	11000	REDPOWL	01011	Fbak in blue port	11001	LPRST in red port	01100	Ck2.5x sampling clk in blue	11010	Fin in red port	01101	Ck2.5x in blue port	11011	Fbak in red port	01110	Ck1.0x in blue port	11100	Ck2.5x sampling clk in red port	01111	Ck0.5x in blue port	11101	Ck2.5x in red port	10000	GRNPOWL	11110	Ck1.0x in red port	10001	LPRST in green port	11111	Ck0.5x in red port
00x00	CLKPLLPOWL	10010	Fin in green port																																																							
00x01	LPRST in clk port	10011	Fbak in green port																																																							
00x10	Fin in clk port	10100	Ck2.5x sampling clk in green port																																																							
00x11	Fbak in clk port	10101	Ck2.5x in green port																																																							
01000	BLUPOWL	10110	Ck1.0x in green port																																																							
01001	LPRST in blue port	10111	Ck0.5x in green port																																																							
01010	Fin in blue port	11000	REDPOWL																																																							
01011	Fbak in blue port	11001	LPRST in red port																																																							
01100	Ck2.5x sampling clk in blue	11010	Fin in red port																																																							
01101	Ck2.5x in blue port	11011	Fbak in red port																																																							
01110	Ck1.0x in blue port	11100	Ck2.5x sampling clk in red port																																																							
01111	Ck0.5x in blue port	11101	Ck2.5x in red port																																																							
10000	GRNPOWL	11110	Ck1.0x in red port																																																							
10001	LPRST in green port	11111	Ck0.5x in red port																																																							

Address: C5 **ANALOG_BIAS_CTRL** **Default: 0x31**

Bit	Mode	Function
7	--	Reserved to 0
6:3	R/W	SBIASL<3:0> (Default: 0110b)
2:0	R/W	SBIASGENL<2:0> : bias generator (Default: 001b)

Address: C6 **ANALOG_COMMON_CTRL2** **Default: 0x20**

Bit	Mode	Function
7	R/W	SIBINL : select bias source 0: auto generate (Default) 1: bias source is set to IB2IN.
6:5	R/W	PAGINL<1:0> : preamp gain selection of R/G/B port (Default=01) 00: max. 11: min.
4	R/W	Analog Equalizer Enable(ENEQL) 0: Disable (Default) 1: Enable
3	R	TMDS internal CTL3 signal status
2	R	TMDS internal CTL2 signal status

1	R	TMDS internal CTL1 signal status
0	R	TMDS internal CTL0 signal status

Address: C7 **Z0_CALIBRATION_CTRL2** **Default: A3h**

Bit	Mode	Function
7	R/W	STUNEL : select calibration 0: Z0 is set by ADJRL<3:0> (Manual) 1: Z0 is auto calibrated (Default)
6	R/W	Z0POWL : (control of clock channel internal 50ohm resistor) 50 ohm impedance match calibration starts after power is stable, then status changes from 0→1 0: off 1: on
5:2	R/W	ADJRL<3:0> : select Z0 impedance value (default 1000)
1:0	R/W	SREXTL<1:0> : select REXT value (select corresponding REXT value on the PCB to SREXTL) 00:4k 01:2k 10:4k/3 11:1k

Address: C8 **CLOCK_PLL_SETTING** **Default: 32h**

Bit	Mode	Function
7	---	Reserved to 0
6:5	R/W	SCKLVCSETL<1:0> : when reset CLK PLL, the reset value of VC node 00: 2.17V 01: 1.98V (Default) 10: 1.79V 11: 1.60V
4:2	R/W	SCKIL<2:0> : PLL charge-pump current (Default= 3'b100) $10u + \langle 4 \rangle * 20u + \langle 3 \rangle * 10u + \langle 2 \rangle * 10u$
1:0	R/W	SCKRL<1:0> : PLL LPF resistor $8k + \langle 1 \rangle * 4k + \langle 0 \rangle * 2k$

Address: C9 **RGB_PLL_SETTING** **Default: 28h**

Bit	Mode	Function
7	---	Reserved to 0
6:5	R/W	SSAVCSETL<1:0> : when reset R/G/B PLL, the reset value of VC node 00: 2.17 01: 1.98 (Default) 10: 1.79 11: 1.60

4:2	R/W	SSAIL<2:0> : PLL charge-pump current (Default:3'b010) 10u+<4>*20u+<3>*10u+<2>*10u
1:0	R/W	SSARL<1:0> : PLL LPF resistor (Default: 2'b00) 8k+<1>*4k+<0>*2k

Address: CA WATCH_DOG_CTRL Default: 40h

Bit	Mode	Function
7	---	Reserved to 0
6	R/W	FIFO R/W Auto Calibration 0: Manual 1: Auto (Default)
5	R/W	R Channel Manual Mode 0: Not Invert (Default) 1: Invert
4	R/W	G Channel Manual Mode 0: Not Invert (Default) 1: Invert
3:2	R/W	CKWDCONL<1:0> : PLL watch dog mode, when CKL<0.7Mhz, reset PLL (Clock) 00: Enable (Default) 01: Keep PLL VCO=SCKVCSETL<1:0> (break PLL loop) 1x: Disable watch dog
1:0	R/W	SAWDCONL<1:0> : PLL watch dog mode, when CKL<0.7Mhz, reset PLL (Sampling Data) 00: Enable (Default) 01: Keep PLL VCO=SSAVCSETL<1:0> (break PLL loop) 1x: Disable watch dog

Address: CB CDR_CTRL0 Default: 0x02

Bit	Mode	Function
7:6	R/W	UDCNT_SEL<1:0> Indicate which channel to be R/W in CRCB[5], CRCE (Only when manual mode (CRCE[7]=0)) 1x:Red 01:Green 00:Blue
5	R	OV_FLAG: When UDCNT fall in undefined phase number (#80~127)
4	R/W	OV_FLAG_CLN: To clean OV_FLAG
3:2	R/W	ADJ_GAIN<1:0> Phase adjust gain. One UP/DOWN could mean to change the phase by 1~4 minimum step sizes.

1:0	R/W	LPF<1:0> LPF selection 00: ACCUMULATION type x1: CONSECUTIVE type, 10: CASCADE type. (Consecutive → Accumulation) (Default)
-----	-----	---

Address: CC **CDR_CTRL1** **Default: 0Ah**

Bit	Mode	Function
7:0	R/W	THR_ACC<7:0> : Threshold to assert UP/DOWN in accumulation LPF.(00010000)

Address: CD **CDR_CTRL2** **Default: 0Ah**

Bit	Mode	Function
7:0	R/W	THR_CONSEC<7:0> : Threshold to assert UP/DOWN in consecutive LPF.(00010000)

CRCC and CRCD values can't be zero.

Address: CE **UP_DOWN_ADJUSTING0** **Default: 80h**

Bit	Mode	Function
7	R/W	UD_AUTO : 1: Auto; 0:Manual
6:0	R/W	UDCNT_FW<6:0> Specify which phase number (#0~79) sent to analog.

Address: CF **UP_DOWN_ADJUSTING1** **Default: 14h**

Bit	Mode	Function
7:0	R/W	WAIT_TIME<7:0> : The minimum period between two phases adjusts. (phase change responding time)(Default: 00010000)

Address: D0 **UP_DOWN_ADJUSTING2**

Bit	Mode	Function
7:0	R	PHASE_REC<7:0> : Records the number of phase adjusting. Default=0. Each time phase is adjusted (up/down) n phases, PHASE_REC will be (inc/dec) by n, with n = ADJ_GAIN+1.

Address: D1 **UP_DOWN_CTRL0** **Default: 92h**

Bit	Mode	Function
7	R/W	ADJ_AUTO_R : Phase adjusting automatically by digital or not, for RED channel. 1: automatic (Default) 0: manual by firmware
6:5	R/W	UPDOWN_R<1:0> : Manually adjust of up/down for PLL, in RED channel. This is only useful when ADJ_AUTO_R is set to 0. 10: UP 01: DOWN 00: hold (Default)
4	R/W	ADJ_AUTO_G : Phase adjusting automatically by digital or not, for GREEN channel. 1: automatic (Default) 0: manual by firmware

3:2	R/W	UPDOWN_G<1:0> : Manually adjust of up/down for PLL, in GREEN channel. This is only useful when ADJ_AUTO_R is set to 0. 10: UP 01: DOWN 00: hold (Default)
1	R/W	ADJ_AUTO_B :Phase adjusting automatically by digital or not, for BLUE channel. 1: automatic (Default) 0: manual by firmware
0	R/W	UP side DOWN 0: Disable 1: Enable

Address: D2 **UP_DOWN_CTRL1** **Default: 0x10**

Bit	Mode	Function
7:6	R/W	UPDOWN_B<1:0> : Manually adjust of up/down for PLL, in BLUE channel. This is only useful when ADJ_AUTO_R is set to 0. 10: UP 01: DOWN 00: hold
5	R/W	Reserved to 0
4	R/W	NL_AUTO : Frequency range selection by digital part automatically. 1: automatic by digital (Default) 0: manual selected by firmware
3:0	R	NL<3:0> : Frequency selected by digital part. (When Xtal is 24.576M) 0000: 0Hz 0001: >165MHz or <25MHz 1110: 25-50 MHz 1000: 50-80 MHz 0110: 80-112 MHz 0100: 112-140 MHz 0011: 140-165 MHz otherwise: invalid

Address: D3 **UP_DOWN_CTRL2** **Default: 30h**

Bit	Mode	Function
7	R/W	CPTEST 0: normal mode, in which clock and data from analog are used. 1: select TSTCKIN/TSTDIN as input 2X5 clock and data respectively, for TESTING.

6:4	R/W	STABLE_CNT<2:0> : Numbers of consecutive frequency change command after which N_FREQ can be adjusted.
3:0	R/W	NL_FW<3:0> : Frequency selected by firmware. The valid values are the same as those listed in previous row. (Read back value in CRD3)

Address: D4 **UP_DOWN_CTRL3** **Default: 00h**

Bit	Mode	Function
7:6	R/W	ERRC_SEL<1:0> 00: original signal 01: debouncing 1 cycle 10: debouncing 1+8 cycle 11: 1+8 cycle debouncing+ DE masking transition of vs/hs+vs+(hs88) to masking DE
5:0	R/W	DEBUG_SEL

HDCP (Only in H series)

Address: D5 **HDCP_CTRL** **Default: 00h**

Bit	Mode	Function
7	R/W	HDCP Key Access SRAM BIST Action 1: start 0: stop & clear after finish.
6	R	HDCP Key Access SRAM BIST Status 1: OK, when test start, clear this bit 0: Fail
5	R	Indicate VSYNC Polarity 0: Positive 1: Negative
4	R/W	Invert VSYNC for HDCP High: Inverted Low: Not Inverted
3	R/W	Indicate VSYNC Polarity Mode: High: manual, decided by CRD5[4] Low: auto, indicate by CRD5[5]
2	R/W	MCU Access DDC data first 0: enable DDC channel and MCU access only when DDC is not busy 1: disable DDC channel and MCU access only
1	R/W	Device Key Access Port download enable High: enable Low: disable

0	R/W	HDCP Enable High: Auto Enable HDCP function, when Tx I2C write Aksv, Low: Disable HDCP
---	-----	---

Address: D6 **DEVICE_KEY_ACCESS_PORT** **Default: 00h**

Bit	Mode	Function
7:0	R/W	When enable device key accessing 40x56 table, the 56-bit key table will be transferred to 64-bit pseudo data with 7th, 15th, 23rd, 31st, 39th, 47th, 55th bits inserted. The inserted data are '0'. And the write sequence is: {D0-Byte0, D0-Byte1, D0-Byte2, D0-Byte3, D0-Byte4, D0-Byte5, D0-Byte6, D0-Byte7}, {D1-Byte0, D1-Byte1, D1-Byte2, D1-Byte3, D1-Byte4, D1-Byte5, D1-Byte6, D1-Byte7},

Address: D7 **DEVICE_KEY_BIST_PATTERN** **Default: 00h**

Bit	Mode	Function
7	R/W	HDCP R/G/B Output Enable 0: Disable(Default) 1: Enable
6:0	R/W	BIST Pattern Input

Address: D8 **HDCP_ADDR_PORT** **Default: 00h**

Bit	Mode	Function
7:0	R/W	Address port for embedded HDCP access

Address: D9 **HDCP_DATA_PORT**

Bit	Mode	Function
7:0	R/W	Data port for embedded HDCP access

HDCP Control Register Map

Hex Address	Write/Read	Size in Bytes	Register Name	Function
0x00	R/W	5	BKSV	Video receiver KSV. This value must always be available for reading, and may be used to determine that the video receiver is HDCP capable. Valid KSVs contain 20 ones and 20 zeros, a characteristic that must be verified by video transmitter hardware before encryption is enable.
0x05	R	3		Read as 0x00
0x08	R	2	Ri'	Link verification response. Updated every 128th frame. It is recommended that graphics systems protect against errors in the I2C transmission by reading this value when unexpected values are received. This value must be available at all times between updates. R0' must be available a maximum of

				100ms after AKSV is received. Subsequent Ri' values must be available a maximum of 128 pixel clocks following the assertion of CTL3
0x0A	R	6		Read as 0x00
0x10	R	5	AKSV	Video transmitter KSV. Writes to this multi-byte value are written least significant byte first. The final write to 0x14 triggers the authentication sequence in the display device.
0x15	R	3		Read as 0x00
0x18	R	8	An	Session random number. This multi-byte value must be written by the graphics system before the KSV is written.
0x20	R	20		Read as 0x00
0x34	R	12		Read as 0x00
0x40	R	1	Bcaps	Bit 6: REPEATER. Video repeater capability. This device is not a repeater. Read as ZERO. Bit 5: READY, KSV FIFO ready. This device does not support repeater capability. Read as ZERO. Bit 4: FAST. This device supports 400Khz transfers. Read as ONE.
0x41	R	2	Bstatus	This device does not support repeater capability. All byte read as 0x00.
0x43	R	1	KSV/FIFO	Read as 0x00
0x44	R	124		Read as 0x00

I2C Control Register Map (DVI DDC side): Address mapping 0x74, 0x75

Hex Address	Write/Read	Size in Bytes	Register Name	Function
0x00	R	5	BKSV	Video receiver KSV. This value must always be available for reading, and may be used to determine that the video receiver is HDCP capable. Valid KSVs contain 20 ones and 20 zeros, a characteristic that must be verified by video transmitter hardware before encryption is enable.
0x05	R	3	Reserved	All bytes read as 0x00
0x08	R	2	Ri'	Link verification response. Updated every 128th frame. It is recommended that graphics systems protect against errors in the I2C transmission by reading this value when unexpected values are received. This value must be available at all times between updates. R0' must be available a maximum of 100ms after AKSV is received. Subsequent Ri' values must be available a maximum of 128 pixel clocks following the assertion of CTL3
0x0A	R	6	Reserved	All bytes read as 0x00
0x10	R/W	5	AKSV	Video transmitter KSV. Writes to this multi-byte value are written least

				significant byte first. The final write to 0x14 triggers the authentication sequence in the display device.
0x15	R	3	Reserved	All bytes read as 0x00
0x18	R/W	8	An	Session random number. This multi-byte value must be written by the graphics system before the KSV is written.
0x20	R	20	Reserved	Only necessary for transmitters.
0x34	R	12	Reserved	All bytes read as 0x00
0x40	R	1	Bcaps	Bit 6: REPEATER. Video repeater capability. This device is not a repeater. Read as ZERO. Bit 5: READY, KSV FIFO ready. This device does not support repeater capability. Read as ZERO. Bit 4: FAST. This device supports 400Khz transfers. Read as ONE.
0x41	R	2	Bstatus	This device does not support repeater capability. All byte read as 0x00.
0x43	R	1	KSV FIFO	Key selection vector FIFO. This device is not a repeater. All byte read as 0x00
0x44	R	124	Reserved	All bytes read as 0x00

Realtek Confidential

Watch Dog

Address: DA
WATCH_DOG_CTRL
Default: 00h

Bit	Mode	Function
7:6	--	Reserved to 0
5	R/W	Auto switch when Display Vsync timeout 0: Disable (Default) 1: Enable
4	R/W	Auto switch when ADC-PLL non-lock 0: Disable (Default) 1: Enable
3	R/W	Auto switch when overflow or underflow 0: Disable (Default) 1: Enable
2	R/W	Auto switch event happen action (for timing) 0: Disable (Default) 1: Free Run
1	R/W	Auto switch event happen action (for data) 0: Disable (Default) 1: Background Turn off <u>overlay enable</u> and <u>switch to background</u> simultaneously.
0	R	Display Vsync timeout flag (status with CRDA [5]) 0: Vsync is present 1: Vsync Timeout The line number of Display HS is equal to Display Vertical Total; this bit is set to "1". Write to clear status.

Macro Vision

Address: DB **MACRO_VISION_CTRL**
Default: 60h

Bit	Mode	Function
7:4	R/W	Skip Line[3:0] Skip Lines after Vsync detected
3	R/W	Test-Mode for Clamp, HS_RAW is directly from PAD 0: Clamp source from normal HS 1: Clamp source from HS_RAW
2	R/W	Odd Detection Mode 0: Line Count (Default) 1: VS Position
1	R	MacroVision Detected (On-line monitor) When detected macrovision occurred, this bit set to 1, else clear to 0.
0	R/W	Macro Vision Enable 0: Disable (Default) 1: Enable

Realtek Confidential

Embedded ADC

Address: DC **ADC_RGB_CTRL** **Default: (56h)**

Bit	Mode	Function
7:6	R/W	PGA (00: Ash=0.9 01: Ash=1.0 10: Ash=1.1 11: Ash=1.2) (Default: 01)
5:4	R/W	PGA (00: Aref=0.9 01: Aref=1.0 10: Aref=1.1 11: Aref=1.2)(Default: 01)
3	R/W	ADC source select (Need to select corresponding ADC_OUT_SOG 0 or 1) 0 : Input0 (Default) 1 : Input1
2	R/W	ADC input mode selection 0 : Single Ended 1 : Differential (Default)
1:0	R/W	Bandwidth Adjustment 00 : 75M 01 : 150M 10 : 300M (Default) 11 : 500M

Address: DD **ADC_RED_CTRL** **Default: (40h)**

Bit	Mode	Function
7	R/W	RED channel clamp mode selection 0: Low clamp (Default) 1: Middle clamp
6:4	R/W	Red channel Clamp Voltage 0~700mV, Step=100mV (Default: 100)
3	R/W	RED channel Offset Depends on Gain 0: RGB Dependent, YPbPr Independent (Default) 1: RGB Independent, YPbPr Independent
2:0	R/W	Red Channel ADC Fine Tune Delay (Step=90ps) (Default: 000)

Address: DE **ADC_GRN_CTRL** **Default: (40h)**

Bit	Mode	Function
7	R/W	GREEN channel clamp mode selection 0: Low clamp (Default) 1: Middle clamp
6:4	R/W	GREEN channel Clamp Voltage 0~700mV, Step=100mV(Default:100)
3	R/W	GREEN channel Offset Depends on Gain 0: RGB Dependent, YPbPr Independent(Default) 1: RGB Independent, YPbPr Independent
2:0	R/W	Green Channel ADC Fine Tune Delay (Step=90ps) (Default:000)

Address: DF **ADC_BLU_CTRL** **Default: (40h)**

Bit	Mode	Function
7	R/W	BLUE channel clamp mode selection 0: Low clamp(Default) 1: Middle clamp
6:4	R/W	BLUE channel Clamp Voltage 0~700mV, Step=100mV (Default:100)
3	R/W	BLUE channel Offset Depends on Gain 0: RGB Dependent, YPbPr Independent(Default) 1: RGB Independent, YPbPr Independent
2:0	R/W	Blue Channel ADC Fine Tune Delay (Step=90ps) (Default: 000)

Address: E0 **RED_GAIN** **Default: (80h)**

Bit	Mode	Function
7:0	R/W	Red Channel Gain Adjust
Address: E1		GRN_GAIN Default: (80h)
Bit	Mode	Function
7:0	R/W	Green Channel Gain Adjust
Address: E2		BLU_GAIN Default: (80h)
Bit	Mode	Function
7:0	R/W	BLUE Channel Gain Adjust
Address: E3		RED_OFFSET Default: (80h)
Bit	Mode	Function
7:0	R/W	Red Channel Offset Adjust
Address: E4		GRN_OFFSET Default: (80h)
Bit	Mode	Function
7:0	R/W	Green Channel Offset Adjust
Address: E5		BLU_OFFSET Default: (80h)
Bit	Mode	Function
7:0	R/W	BLUE Channel Offset Adjust
Address: E6		SOG_CTRL Default: (20h)
Bit	Mode	Function
7:6	--	Reserved to 0
5:0	R/W	SOG Reference Control 0~630mV, Step=10mV (Default: 100000)

Address: E7 **Reserved**

Default:

- ! The lowest voltage of SOG_IN is clamped to about 200mV.
- ! SOG reference control set the threshold voltage to extract the sync signal from G. The threshold voltage maps the value 0~63 to 0~630 mV.

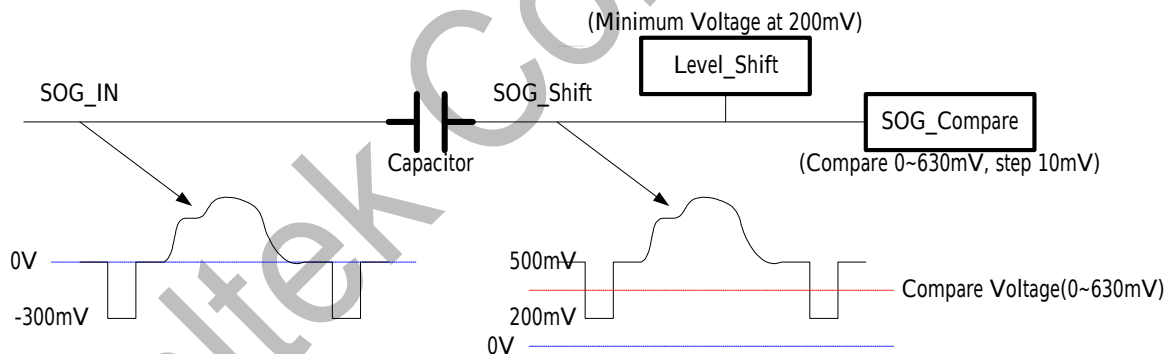

Address: E8 **ADC_POWER_CTRL** Default: (08h)

Bit	Mode	Function
7:6	---	Reserved to 0
5	R/W	SOG Power On 0 : Power Down(Default) 1 : Power On
4	R/W	Set to 0
3	R/W	Band-gap Power On 0 : Power Down 1 : Power On (Default)
2	R/W	Red Channel ADC Power On 0 : Power Down (Default) 1 : Power On

1	R/W	Green Channel ADC Power On 0 : Power Down (Default) 1 : Power On
0	R/W	Blue Channel ADC Power On 0 : Power Down (Default) 1 : Power On

! Note that Band-gap power can only turn off just in the power down mode, or the chip may run abnormally.

! When in power saving mode, only R/G/B channel will be power down, it doesn't include the SOG & band-gap.

Address: E9 ADC_CLOCK Default: (01h)

Bit	Mode	Function
7	R/W	Input Clock Polarity 0: Negative (Default) 1: Positive
6	R/W	Output Clock Polarity 0: Normal (Default) 1: Inverted
5:4	R/W	ADC_Out Pixel Extra Delay 00: 1.05ns (Default) 01: 1.39ns 10: 1.69ns 11: 1.97ns
3	R/W	1x or 2x from APLL (For better clock duty cycle) 0: 1X (Default) 1: 2X
2	R/W	Single Ended or Differential clock from APLL 0: Differential (Default) 1: Single Ended
1:0	R/W	Duty Stabilizer (Default: 01)

Address: EA ADC_TEST Default: (04h)

Bit	Mode	Function
7	--	Reserved to 0
6:4	R/W	Test Output Selection(PAD : SOGIN) 000:X/X(Hi-Z) Normal SOG Mode (Default) 001:GND/GND 010:VRBIR/VREFN 011:VCMI/VCMO 100:VRTIR/VREFP 101:VMID/GND 110:VOFFSET/GND 111:VDD/VDD
3:2	R/W	SOG Resistor 00: Poly R=100K, external C=47nF 01: Poly R=500K, external C=10nf (Default) The others: NA
1:0	R/W	Clock Output Divider 00 : 1/1 (Default) 01 : 1/2 10 : 1/3

		11 : 1/4
--	--	----------

Address: EB **ADC_IBIAS2** **Default: (53h)**

Bit	Mode	Function
7:6	R/W	APLL_IB60U[1:0] Bias Current of APLL_IB60U 00:48uA 01:60uA (Default) 10:72uA 11:84uA
5:4	R/W	ADC_SF[1:0] Bias Current of ADC_SF 00:15u 01:20u (Default) 10:25u 11:30u
3	R/W	ADC_REF Bias Current of ADC_REF 0:60u (Default) 1:80u
2:0	R/W	ADC_OP[2:0] Bias Current of ADC_OP 000:5u 001:10u 010:15u 011:20u (Default) 100:25u 101:30u 110:35u 111:40u

Address: EC **ADC_VBIAS0** **Default: (21h)**

Bit	Mode	Function
7	R/W	Resistor Reference (REFIO) 0:Ref. To Internal R (Default) 1:Ref. To External R=2K
6:4	R/W	ADC_VBIAS0[6:4] Band gap Voltage 000:0.890 001:0.841 010:0.792 (Default) 011:0.742 100:0.693 101:0.644 110:0.594 111:0.545
3:2	R	Temperature sensor 0~120 (70+38*1.2) 00: 30 degree 01: 30-60 degree 10: 60-90 degree 11: 120 degree
1:0	R/W	ADC_VBIAS0[1:0] Band gap Voltage 00:0.775 01:0.792 (Default) 10:0.810 11:0.829

Address: ED **ADC_VBIAS1** **Default: (0Dh)**

Bit	Mode	Function
7	---	Reserved to 0
6	R/W	R Channel Clamp to -300mV 0: 0mV (Default) 1: -300mV
5	R/W	G Channel Clamp to -300mV 0: 0mV (Default) 1: -300mV
4	R/W	B Channel Clamp to -300mV 0: 0mV (Default) 1: -300mV
3	R/W	Vcmo with Lower VDD Ratio //(1) 0: Lower, 1.068 1: Normal, 1.122 (Default)
2	R/W	Vcmo from VBG or from VDD //(1) 0: from VBG (constant) 1: from VDD (Default)
1:0	R/W	Vcmo Voltage[1:0] //(01) 00: 0.90 01: 1.00 (Default) 11: 1.05 11: 1.10

Address: EE **PTNPOS_H** **Default: 00h**

Bit	Mode	Function
7	R/W	Enable Test 0: Finish (and result sequence is R-G-B) (Default) 1: Start
6:4	R/W	Test Pattern V Position Register [10:8] Assign the test pattern digitized position in line after V_Start.
3	--	Reserved to 0
2:0	R/W	Test Pattern H Position Register [10:8] Assign the test pattern digitized position in pixel after H_Start.

Address: EF **PTNPOS_V_L**

Bit	Mode	Function
7:0	R/W	Test Pattern V Position Register [7:0] Assign the test pattern digitized position in line after V_Start..

Address: F0 **PTNPOS_H_L**

Bit	Mode	Function
7:0	R/W	Test Pattern H Position Register [7:0] Assign the test pattern digitized position in line after H_Start..

Use PTNPOS to assign the pixel position after HSYNC leading edge that input signal digitized. Each time the PTNPOS is written, the digitized results will be loaded into PTNRD, PTNGD and PTNBD. For test issue, make the input signal a fixed pattern before PTNPOS is written. Then the same digitized output will be got.

Address: F1 **PTNRD**

Bit	Mode	Function
-----	------	----------

7:0	R	Test Pattern Digitized Result.
-----	---	---------------------------------------

- | The test pattern digitized result after HSYNC leading edge about PTNPOS pixel.
- | The 1st time read result is Red, the second read result is Green, and the third read result is Blue
- | The read pointer should be reset when 1. PTNRD is written 2. Enable Test starts.
- | The read back Test Pattern Digitized Result value address should be auto-increase, the sequence is shown above

Realtek Confidential

Cyclic-Redundant-Check

Address: F2 **OP_CRC_CTRL (Output CRC Control Register)** **Default: 00h**

Bit	Mode	Function
7:1	--	Reserved to 0
0	R/W	Output CRC Control: 0: Stop or finish (Auto-stop after checked a completed display frame) (Default) 1: Start

CRC function = $X^{24} + X^7 + X^2 + X + 1$.

Address: F3 **OP_CRC_CHECKSUM (Output CRC Checksum)**

Bit	Mode	Function
7:0	R/W	1 st read=> Output CRC-24 bit 23~16 2 nd read=> Output CRC-24 bit 15~8 3 rd read=> Output CRC-24 bit 7~0

- I The read pointer should be reset when 1. OP_CRC_BYTE is written 2. Output CRC Control starts.
- I The read back CRC value address should be auto-increase, the sequence is shown above

Realtek Confidential

DDC Special Function Access (DDC/CI)

Address: F4 **DDC_SET_SLAVE** **Default: 6E**

Bit	Mode	Function
7:1	R/W	DDC Slave Address to decode
0	--	Reserved to 0

Address: F5 **DDC_SUB_IN**

Bit	Mode	Function
7:0	R	DDC Sub-Address Received

Address: F6 **DDC_DATA_IN**

Bit	Mode	Function
7:0	R/W	Read: DDC Data Received (16-bytes buffer) Write: DDC Data Received (16-bytes buffer) Every Read/Write access, the buffer index is auto-decreased/increased.

Address: F7 **DDC_CTRL** **Default: 00h**

Bit	Mode	Function
7	R/W	Start BIST function for DDC SRAM 0: finished and clear 1: start
6	R	Test result about DVI DDC SRAM 0: fail 1: ok
5	R	Test result about ADC DDC SRAM 0: fail 1: ok
4	--	Reserved
3	R/W	Auto reset DDC_DATA Buffer 0: disable 1: enable In host (pc) write enable, when DDC write (No START after DDC_SUB), reset DDC_DATA buffer.
2	R/W	Reset DDC_DATA buffer 0: Finish 1: Reset
1	R/W	DDC_DATA buffer write enable

		0: host (pc) write enable 1: slave (mcu) write enable Both PC and MCU can read DDC_DATA buffer, but only one can write DDC_DATA buffer.
0	R/W	Channel Select 0: from ADC DDC 1: from DVI DDC

Address: F8 DDC_STATUS

Bit	Mode	Function
7	R	DDC_DATA_BUFFER Full If DDC_DATA buffer is full, this bit is set to "1". (On-line monitor) The DDC_DATA buffer Full status will be on-line-monitor the condition, once it becomes full, it kept high, if it is not-full, then it goes low.
6	R	DDC_DATA_BUFFER Empty If DDC_DATA buffer is empty, this bit is set to "1". (On-line monitor) The DDC_DATA buffer Empty status will be on-line-monitor the condition, once it becomes empty, it kept high, if it is not-empty, then it goes low.
5	--	Reserved to 0
4	R	If DDC_STOP signal occurs, this bit is set to "1". Write clear
3	R	If DDC_DATA_OUT loaded to serial-out-byte, this bit is set to "1". Write clear
2	R	If DDC_DATA_IN latched, this bit is set to "1". Write clear
1	R	If DDC_SUB latched, this bit is set to "1" Write clear
0	R	If DDC_SLAVE latched, this bit is set to "1" Write clear

Address: F9 DDC_IRQ_CTRL Default: 20h

Bit	Mode	Function
7	R/W	0: Disable the DDC_DATA_BUFFER Full signal as an interrupt source 1: Enable the DDC_DATA_BUFFER Full signal as an interrupt source
6	R/W	0: Disable the DDC_DATA_BUFFER Empty signal as an interrupt source 1: Enable the DDC_DATA_BUFFER Empty signal as an interrupt source
5	---	Reserved
4	R/W	0: Disable the DDC_STOP signal as an interrupt source 1: Enable the DDC_STOP signal as an interrupt source
3	R/W	0: Disable the DDC_DATA_OUT loaded to serial-out-byte as an interrupt source 1: Enable the DDC_DATA_OUT loaded to serial-out-byte as an interrupt source
2	R/W	0: Disable the DDC_DATA_IN latched as an interrupt source 1: Enable the DDC_DATA_IN latched as an interrupt source
1	R/W	0: Disable the DDC_SUB latched as an interrupt source

		1: Enable the DDC_SUB latched as an interrupt source
0	R/W	0: Disable the DDC_SLAVE latched as an interrupt source 1: Enable the DDC_SLAVE latched as an interrupt source

Realtek Confidential

DDC Channel (ADC/DVI)

(Refers to the VESA “Display Data Channel Standard” for detailed)

Address: FA **DDC_ENABLE (DDC Channel Enable Register)** **Default: 00h**

Bit	Mode	Function
7:5	R/W	DDC Channel Address Least Significant 3 Bits (The default DDC channel address MSB 4 Bits is “A”)
4	R/W	DDC Write Status (for external DDC access only) It is cleared after write.
3	R/W	DDC SRAM Write Enable (for external DDC access only) 0: Disable 1: Enable
2	R/W	DDC De-bounce Enable 0: Disable 1: Enable (with crystal/4)
1	R/W	DDC Channel RAM Size 0: 128 bytes 1: 256 bytes
0	R/W	DDC Channel Enable Bit 0: MCU access Enable 1: DDC channel Enable

Address: FB **DDC_INDEX (DDC SRAM R/W Index Register)**

Bit	Mode	Function
7:0	R/W	DDC SRAM Read/Write Index Register [7:0]

The DDC channel index register will be auto increased one by one after each read or write cycle.

Address: FC **DDC_ACCESS_PORT (DDC Channel ACCESS Port)**

Bit	Mode	Function
7:0	R/W	DDC SRAM Read/Write Port

** The DDC function can still work when Power_Down & Power_Save.

** After reset, the register will be set to default value, but the SRAM will keep original data.

Address: FD **DDC_DVI_ENABLE (DDC Channel Enable Register)** **Default: 00h**

Bit	Mode	Function
7:5	R/W	DVI DDC Channel Address Least Significant 3 Bits (The default DDC channel address MSB 4 Bits is “A”)
4	R	DVI DDC External Write Status (for external DDC access only) It is cleared after write.
3	R/W	DVI DDC External Write Enable (for external DDC access only)

		0: Disable 1: Enable
2	R/W	DVI DDC Debounce Enable 0: Disable 1: Enable (with crystal/4)
1	R/W	DVI DDC Channel RAM Size 0: 128 bytes 1: 256 bytes
0	R/W	DVI DDC Channel Enable Switch 0: MCU access Enable 1: External DDC access Enable

Address: FE DDC_DVI_INDEX (DDC SRAM R/W Index Register)

Bit	Mode	Function
7:0	R/W	DVI DDC SRAM Read/Write Index Register [7:0]

! The DDC channel index register will be auto increased one by one after each read or write cycle.

Address: FF DDC_DVI_ACCESS_PORT (DDC Channel ACCESS Port)

Bit	Mode	Function
7:0	R/W	DVI DDC SRAM Read/Write Port

! The DDC function can still work when Power_Down & Power_Save.

! After reset, the register will be set to default value, but the SRAM will keep original data.

Embedded OSD

Addressing and Accessing Register

ADDRESS	BIT							
	7	6	5	4	3	2	1	0
High Byte	A15	A14	A13	A12	A11	A10	A9	A8
Low Byte	A7	A6	A5	A4	A3	A2	A1	A0

Figure 20. Addressing and Accessing Registers

Date	BIT							
Byte 0	D7	D6	D5	D4	D3	D2	D1	D0
Byte 1	D7	D6	D5	D4	D3	D2	D1	D0
Byte 2	D7	D6	D5	D4	D3	D2	D1	D0

Figure 2. Data Registers

All kind of registers can be controlled and accessed by these 2 bytes, and each address contains 3-byte data, details are described as follows:

Write mode: [A15:A14] select which byte to write

-00: Byte 0 -01:Byte 1 -10: Byte 2 -11: All

**All data are sorted by these three Bytes (Byte0~Byte2)*

[A13] Auto Load (Double Buffer)

[A12] Address indicator

-0: Window and frame control registers.

-1: Font Select and font map SRAM

[A11:A0] Address mapping

- Font Select and font map SRAM address: 000~EFF **3.75k*3byte**

-Frame control register address: 000~0xx (**Latch**)

-Window control register address: 100~1xx (**Latch**)

** Selection of SRAM address or Latch address selection is determined by A12!*

Example:

Bit [15:14]=00

-All data followed are written to byte0 and address increases.

Byte0 à Byte0 à Byte0... (Address will auto increase)

Bit [15:14] =01

-All data followed are written to byte1 and address increases.

Byte1 à Byte1 à Byte1 ... (Address will auto increase)

Bit [15:14] =11

- Address will be increased after each 3-byte data written.

Byte0 à Byte1 à Byte2 à Byte0 à Byte1 à Byte2... (Address will auto increase)

Window control registers

- l Windows all support shadow/border/3D button
- l Window0, 5, 6, 7 support gradient functions.
- l Window 4, 5, 6, 7 start/end resolution are 1line(pixel), Window 0, 1, 2, 3 start/end resolution are 4line(pixel),
- l All window start and end position include the *special effect (border/shadow/3D button)* been assigned
- l Font comes after windows by 10 pixels, so you should compensate 10 pixels on windows to meet font position

Window 0 Shadow/Border/Gradient

Address: 100h

Byte 0

Bit	Mode	Function
7:6	--	Reserved
5:3	W	Window 0 shadow/border width or 3D button thickness in pixel unit 000~111: 1 ~ 8 pixel
2:0	W	Window 0 shadow/border height in line unit 000~111: 1 ~ 8 line It must be the same as bit[5:3] for 3D button thickness

Byte 1

Bit	Mode	Function
7:4	W	Window 0 shadow color index in 16-color LUT For 3D window, it is the left-top/bottom border color

3:0	W	Window 0 border color index in 16-color LUT For 3D window, it is the right-bottom/top border color
-----	---	---

Byte 2

Bit	Mode	Function
7	W	R Gradient Polarity 0: Decrease 1: Increase
6	W	G Gradient Polarity 0: Decrease 1: Increase
5	W	B Gradient Polarity 0: Decrease 1: Increase
4:3	W	Gradient level 00: 1 step per level 01: Repeat 2 step per level 10: Repeat 3 step per level 11: Repeat 4 step per level
2	W	Enable Red Color Gradient
1	W	Enable Green Color Gradient
0	W	Enable Blue Color Gradient

Window 0 start position
Address: 101h

Byte 0

Bit	Mode	Function
7:2	W	Window 0 horizontal start [5:0]
1:0	--	Reserved

Byte 1

Bit	Mode	Function
7:5	W	Window 0 vertical start [2:0] line
4:0	W	Window 0 horizontal start [10:6] pixel

Byte 2

Bit	Mode	Function
7:0	W	Window 0 vertical start [10:3] line

Start position must be increments of four.

Window 0 end position
Address: 102h

Byte 0

Bit	Mode	Function
7:2	W	Window 0 horizontal end [5:0]
1:0	--	Reserved

Byte 1

Bit	Mode	Function
7:5	W	Window 0 vertical end [2:0] line
4:0	W	Window 0 horizontal end [10:6] pixel

Byte 2

Bit	Mode	Function
7:0	W	Window 0 vertical end [10:3] line

End position must be increments of four.

Window 0 control
Address: 103h

Byte 0

Bit	Mode	Function
7:0	--	Reserved

Byte 1

Bit	Mode	Function
7	--	Reserved

6:4	W	111: 7 level per gradient 110: 6 level per gradient 101: 5 level per gradient 100: 4 level per gradient 011: 3 level per gradient 010: 2 level per gradient 001: 1 level per gradient 000: 8 level per gradient
3:0	W	Window 0 color index in 16-color LUT

Byte 2

default: 00h

Bit	Mode	Function
7	W	Reserved
6	W	Gradient function 0: Disable 1: Enable
5	W	Gradient direction 0: Horizontal 1: Vertical
4	W	Shadow/Border/3D button 0: Disable 1: Enable
3:1	W	Window 0 Type 000: Shadow Type 1 001: Shadow Type 2 010: Shadow Type 3 011: Shadow Type 4 100: 3D Button Type 1 101: 3D Button Type 2 110: Reserved 111: Border
0	W	Window 0 Enable 0: Disable 1: Enable

Window 1 Shadow/Border/Gradient
Address: 104h

Byte 0

Bit	Mode	Function
7:6	W	Reserved
5:3	W	Window 1 shadow/border width or 3D button thickness in pixel unit 000~111: 1 ~ 8 pixel
2:0	W	Window 1 shadow/border height in line unit 000~111: 1 ~ 8 line It must be the same as bit[5:3] for 3D button thickness

Byte 1

Bit	Mode	Function
7:4	W	Window 1 shadow color index in 16-color LUT For 3D window, it is the left-top/bottom border color
3:0	W	Window 1 border color index in 16-color LUT For 3D window, it is the right-bottom/top border color

Byte 2

Bit	Mode	Function
7:0	W	Reserved

Window 1 start position
Address: 105h

Byte 0

Bit	Mode	Function
7:2	W	Window 1 horizontal start [5:0]
3:0	--	Reserved

Byte 1

Bit	Mode	Function
7:5	W	Window 1 vertical start [2:0] line
4:0	W	Window 1 horizontal start [10:6] pixel

Byte 2

Bit	Mode	Function
7:0	W	Window 1 vertical start [10:3] line

Start position must be increments of four.

Window 1 end position
Address: 106h

Byte 0

Bit	Mode	Function
7:2	W	Window 1 horizontal end [5:0]
2:0	--	Reserved

Byte 1

Bit	Mode	Function
7:5	W	Window 1 vertical end [2:0] line
4:0	W	Window 1 horizontal end [10:6] pixel

Byte 2

Bit	Mode	Function
7:0	W	Window 1 vertical end [10:3] line

End position must be increments of four.

Realtek Confidential

Window 1 control
Address: 107h

Byte 0

Bit	Mode	Function
7:0	--	Reserved

Byte 1

Bit	Mode	Function
7:4	--	Reserved
3:0	W	Window 1 color index in 16-color LUT

Byte 2

default: 00h

Bit	Mode	Function
7:5	W	Reserved
4	W	Shadow/Border/3D button 0: Disable 1: Enable
3:1	W	Window 1 Type 000: Shadow Type 1 001: Shadow Type 2 010: Shadow Type3 011: Shadow Type 4 100: 3D Button Type 1 101: 3D Button Type 2 110: Reserved 111: Border
0	W	Window 1 Enable 0: Disable 1: Enable

Window 2 Shadow/Border/Gradient
Address: 108h

Byte 0

Bit	Mode	Function
7:6	W	Reserved
5:3	W	Window 2 shadow/border width or 3D button thickness in pixel unit 000~111: 1 ~ 8 pixel
2:0	W	Window 2 shadow/border height in line unit 000~111: 1 ~ 8 line It must be the same as bit[5:3] for 3D button thickness

Byte 1

Bit	Mode	Function
7:4	W	Window 2 shadow color index in 16-color LUT For 3D window, it is the left-top/bottom border color
3:0	W	Window 2 border color index in 16-color LUT For 3D window, it is the right-bottom/top border color

Byte 2

Bit	Mode	Function
7:0	W	Reserved

Window 2 start position

Address: 109h

Byte 0

Bit	Mode	Function
7:2	W	Window 2 horizontal start [5:0]
1:0	--	Reserved

Byte 1

Bit	Mode	Function
7:5	W	Window 2 vertical start [2:0] line
4:0	W	Window 2 horizontal start [10:6] pixel

Byte 2

Bit	Mode	Function
7:0	W	Window 2 vertical start [10:3] line

Start position must be increments of four.

Window 2 end position

Address: 10Ah

Byte 0

Bit	Mode	Function
7:2	W	Window 2 horizontal end [5:0]
1:0	--	Reserved

Byte 1

Bit	Mode	Function
7:5	W	Window 2 vertical end [2:0] line
4:0	W	Window 2 horizontal end [10:6] pixel

Byte 2

Bit	Mode	Function
-----	------	----------

7:0	W	Window 2 vertical end [10:3] line
-----	---	-----------------------------------

End position must be increments of four.

Window 2 control
Address: 10Bh

Byte 0

Bit	Mode	Function
7:0	--	Reserved

Byte 1

Bit	Mode	Function
7:4	--	Reserved
3:0	W	Window 2 color index in 16-color LUT

Byte 2

default: 00h

Bit	Mode	Function
7:5	W	Reserved
4	W	Shadow/Border/3D button 0: Disable 1: Enable
3:1	W	Window 2 Type 000: Shadow Type 1 001: Shadow Type 2 010: Shadow Type3 011: Shadow Type 4 100: 3D Button Type 1 101: 3D Button Type 2 110: Reserved 111: Border
0	W	Window 2 Enable 0: Disable 1: Enable

Window 3 Shadow/Border/Gradient
Address: 10Ch

Byte 0

Bit	Mode	Function
7:6	W	Reserved
5:3	W	Window 3 shadow/border width or 3D button thickness in pixel unit 000~111: 1 ~ 8 pixel
2:0	W	Window 3 shadow/border height in line unit

		000~111: 1 ~ 8 line It must be the same as bit[5:3] for 3D button thickness
--	--	--

Byte 1

Bit	Mode	Function
7:4	W	Window 3 shadow color index in 16-color LUT For 3D window, it is the left-top/bottom border color
3:0	W	Window 3 border color index in 16-color LUT For 3D window, it is the right-bottom/top border color

Byte 2

Bit	Mode	Function
7:0	W	Reserved

Window 3 start position

Address: 10Dh

Byte 0

Bit	Mode	Function
7:2	W	Window 3 horizontal start [5:0]
1:0	--	Reserved

Byte 1

Bit	Mode	Function
7:5	W	Window 3 vertical start [2:0] line
4:0	W	Window 3 horizontal start [10:6] pixel

Byte 2

Bit	Mode	Function
7:0	W	Window 3 vertical start [10:3] line

Start position must be increments of four.

Window 3 end position

Address: 10Eh

Byte 0

Bit	Mode	Function
7:2	W	Window 3 horizontal end [5:0]
1:0	--	Reserved

Byte 1

Bit	Mode	Function
7:5	W	Window 3 vertical end [2:0] line
4:0	W	Window 3 horizontal end [10:6] pixel

Byte 2

Bit	Mode	Function
7:0	W	Window 3 vertical end [10:3] line

End position must be increments of four.

Window 3 control

Address: 10Fh

Byte 0

Bit	Mode	Function
7:0	--	Reserved

Byte 1

Bit	Mode	Function
7:4	--	Reserved
3:0	W	Window 3 color index in 16-color LUT

Byte 2

default: 00h

Bit	Mode	Function
7:5	W	Reserved
4	W	Shadow/Border/3D button 0: Disable 1: Enable
3:1	W	Window 3 Type 000: Shadow Type 1 001: Shadow Type 2 010: Shadow Type3 011: Shadow Type 4 100: 3D Button Type 1 101: 3D Button Type 2 110: Reserved 111: Border
0	W	Window 3 Enable 0: Disable 1: Enable

Window 4 Shadow/Border/Gradient

Address: 110h

Byte 0

Bit	Mode	Function
7:6	W	Reserved
5:3	W	Window 4 shadow/border width or 3D button thickness in pixel unit

		000~111: 1 ~ 8 pixel
2:0	W	Window 4 shadow/border height in line unit 000~111: 1 ~ 8 line It must be the same as bit[5:3] for 3D button thickness

Byte 1

Bit	Mode	Function
7:4	W	Window 4 shadow color index in 16-color LUT For 3D window, it is the left-top/ bottom border color
3:0	W	Window 4 border color index in 16-color LUT For 3D window, it is the right-bottom/top border color

Byte 2

Bit	Mode	Function
7:0	W	Reserved

Window 4 start position

Address: 111h

Byte 0

Bit	Mode	Function
7:2	W	Window 4 horizontal start [5:0]
2:0	--	Reserved

Byte 1

Bit	Mode	Function
7:5	W	Window 4 vertical start [2:0] line
4:0	W	Window 4 horizontal start [10:6] pixel

Byte 2

Bit	Mode	Function
7:0	W	Window 4 vertical start [10:3] line

Window 4 end position

Address: 112h

Byte 0

Bit	Mode	Function
7:2	W	Window 4 horizontal end [5:0]
1:0	--	Reserved

Byte 1

Bit	Mode	Function
7:5	W	Window 4 vertical end [2:0] line
4:0	W	Window 4 horizontal end [10:6] pixel

Byte 2

Bit	Mode	Function
7:0	W	Window 4 vertical end [10:3] line

Window 4 control
Address: 113h

Byte 0

Bit	Mode	Function
7:0	--	Reserved

Byte 1

Bit	Mode	Function
7:4	--	Reserved
3:0	W	Window 4 color index in 16-color LUT

Byte 2

default: 00h

Bit	Mode	Function
7:5	W	Reserved
4	W	Shadow/Border/3D button 0: Disable 1: Enable
3:1	W	Window 4 Type 000: Shadow Type 1 001: Shadow Type 2 010: Shadow Type3 011: Shadow Type 4 100: 3D Button Type 1 101: 3D Button Type 2 110: Reserved 111: Border
0	W	Window 4 Enable 0: Disable 1: Enable

Window 5 Shadow/Border/Gradient
Address: 114h

Byte 0

Bit	Mode	Function
7:6	W	Reserved
5:3	W	Window 5 shadow/border width or 3D button thickness in pixel unit 000~111: 1 ~ 8 pixel

2:0	W	Window 5 shadow/border height in line unit 000~111: 1 ~ 8 line It must be the same as bit[5:3] for 3D button thickness
-----	---	--

Byte 1

Bit	Mode	Function
7:4	W	Window 5 shadow color index in 16-color LUT For 3D window, it is the left-top/bottom border color
3:0	W	Window 5 border color index in 16-color LUT For 3D window, it is the right-bottom/top border color

Byte 2

Bit	Mode	Function
7	W	R Gradient Polarity 0: Decrease 1: Increase
6	W	G Gradient Polarity 0: Decrease 1: Increase
5	W	B Gradient Polarity 0: Decrease 1: Increase
4:3	W	Gradient level 00: 1 step per level 01: Repeat 2 step per level 10: Repeat 3 step per level 11: Repeat 4 step per level
2	W	Enable Red Color Gradient
1	W	Enable Green Color Gradient
0	W	Enable Blue Color Gradient

Window 5 start position

Address: 115h

Byte 0

Bit	Mode	Function
7:2	W	Window 5 horizontal start [5:0]
1:0	--	Reserved

Byte 1

Bit	Mode	Function
-----	------	----------

7:5	W	Window 5 vertical start [2:0] line
4:0	W	Window 5 horizontal start [10:6] pixel

Byte 2

Bit	Mode	Function
7:0	W	Window 5 vertical start [10:3] line

Window 5 end position

Address: 116h

Byte 0

Bit	Mode	Function
7:2	W	Window 5 horizontal end [5:0]
1:0	--	Reserved

Byte 1

Bit	Mode	Function
7:5	W	Window 5 vertical end [2:0] line
4:0	W	Window 5 horizontal end [10:6] pixel

Byte 2

Bit	Mode	Function
7:0	W	Window 5 vertical end [10:3] line

Window 5 control

Address: 117h

Byte 0

Bit	Mode	Function
7:0	--	Reserved

Byte 1

Bit	Mode	Function
7	--	Reserved
6:4	W	111: 7 level per gradient 110: 6 level per gradient 101: 5 level per gradient 100: 4 level per gradient 011: 3 level per gradient 010: 2 level per gradient 001: 1 level per gradient 000: 8 level per gradient
3:0	W	Window 5 color index in 16-color LUT

Byte 2 default: 00h

Bit	Mode	Function
7	W	Reserved
6	W	Gradient function 0: Disable 1: Enable
5	W	Gradient direction 0: Horizontal 1: Vertical
4	W	Shadow/Border/3D button 0: Disable 1: Enable
3:1	W	Window 5 Type 000: Shadow Type 1 001: Shadow Type 2 010: Shadow Type3 011: Shadow Type 4 100: 3D Button Type 1 101: 3D Button Type 2 110: Reserved 111: Border
0	W	Window 5 Enable 0: Disable 1: Enable

Window 6 Shadow/Border/Gradient
Address: 118h

Byte 0

Bit	Mode	Function
7:6	W	Reserved
5:3	W	Window 6 shadow/border width or 3D button thickness in pixel unit 000~111: 1 ~ 8 pixel
2:0	W	Window 6 shadow/border height in line unit 000~111: 1 ~ 8 line It must be the same as bit[5:3] for 3D button thickness

PS: This is for non-rotary, rotate 270, rotate 90 and 180.

Byte 1

Bit	Mode	Function
-----	------	----------

7:4	W	Window 6 shadow color index in 16-color LUT For 3D window, it is the left-top/ bottom border color
3:0	W	Window 6 border color index in 16-color LUT For 3D window, it is the right-bottom/top border color

Byte 2

Bit	Mode	Function
7	W	R Gradient Polarity 0: Decrease 1: Increase
6	W	G Gradient Polarity 0: Decrease 1: Increase
5	W	B Gradient Polarity 0: Decrease 1: Increase
4:3	W	Gradient level 00: 1 step per level 01: Repeat 2 step per level 10: Repeat 3 step per level 11: Repeat 4 step per level
2	W	Enable Red Color Gradient
1	W	Enable Green Color Gradient
0	W	Enable Blue Color Gradient

Window 6 start position

Address: 119h

Byte 0

Bit	Mode	Function
7:2	W	Window 6 horizontal start [5:0]
1:0	--	Reserved

Byte 1

Bit	Mode	Function
7:5	W	Window 6 vertical start [2:0] line
4:0	W	Window 6 horizontal start [10:6] pixel

Byte 2

Bit	Mode	Function
7:0	W	Window 6 vertical start [10:3] line

Window 6 end position
Address: 11Ah

Byte 0

Bit	Mode	Function
7:2	W	Window 6 horizontal end [5:0]
1:0	--	Reserved

Byte 1

Bit	Mode	Function
7:5	W	Window 6 vertical end [2:0] line
4:0	W	Window 6 horizontal end [10:6] pixel

Byte 2

Bit	Mode	Function
7:0	W	Window 6 vertical end [10:3] line

Window 6 control
Address: 11Bh

Byte 0

Bit	Mode	Function
7:0	--	Reserved

Byte 1

Bit	Mode	Function
7	--	Reserved
6:4	W	111: 7 level per gradient 110: 6 level per gradient 101: 5 level per gradient 100: 4 level per gradient 011: 3 level per gradient 010: 2 level per gradient 001: 1 level per gradient 000: 8 level per gradient
3:0	W	Window 6 color index in 16-color LUT

Byte 2

default: 00h

Bit	Mode	Function
7	W	Reserved
6	W	Gradient function 0: Disable 1: Enable

5	W	Gradient direction 0: Horizontal 1: Vertical
4	W	Shadow/Border/3D button 0: Disable 1: Enable
3:1	W	Window 6 Type 000: Shadow Type 1 001: Shadow Type 2 010: Shadow Type3 011: Shadow Type 4 100: 3D Button Type 1 101: 3D Button Type 2 110: Reserved 111: Border
0	W	Window 6 Enable 0: Disable 1: Enable

Window 7 Shadow/Border/Gradient
Address: 11Ch

Byte 0

Bit	Mode	Function
7:6	W	Reserved
5:3	W	Window 7 shadow/border width or 3D button thickness in pixel unit 000~111: 1 ~ 8 pixel
2:0	W	Window 7 shadow/border height in line unit 000~111: 1 ~ 8 line It must be the same as bit[5:3] for 3D button thickness

PS: This is for non-rotary, rotate 270, rotate 90 and 180.

Byte 1

Bit	Mode	Function
7:4	W	Window 7 shadow color index in 16-color LUT For 3D window, it is the left-top/bottom border color
3:0	W	Window 7 border color index in 16-color LUT For 3D window, it is the right-bottom/top border color

Byte 2

Bit	Mode	Function
-----	------	----------

7	W	R Gradient Polarity 0: Decrease 1: Increase
6	W	G Gradient Polarity 0: Decrease 1: Increase
5	W	B Gradient Polarity 0: Decrease 1: Increase
4:3	W	Gradient level 00: 1 step per level 01: Repeat 2 step per level 10: Repeat 3 step per level 11: Repeat 4 step per level
2	W	Enable Red Color Gradient
1	W	Enable Green Color Gradient
0	W	Enable Blue Color Gradient

Window 7 start position
Address: 11Dh

Byte 0

Bit	Mode	Function
7:2	W	Window 7 horizontal start [5:0]
1:0	--	Reserved

Byte 1

Bit	Mode	Function
7:5	W	Window 7 vertical start [2:0] line
4:0	W	Window 7 horizontal start [10:6] pixel

Byte 2

Bit	Mode	Function
7:0	W	Window 7 vertical start [10:3] line

Window 7 end position
Address: 11Eh

Byte 0

Bit	Mode	Function
7:2	W	Window 7 horizontal end [5:0]
1:0	--	Reserved

Byte 1

Bit	Mode	Function
7:5	W	Window 7 vertical end [2:0] line
4:0	W	Window 7 horizontal end [10:6] pixel

Byte 2

Bit	Mode	Function
7:0	W	Window 7 vertical end [10:3] line

Window 7 control

Address: 11Fh

Byte 0

Bit	Mode	Function
7:0	--	Reserved

Byte 1

Bit	Mode	Function
7	--	Reserved
6:4	W	111: 7 level per gradient 110: 6 level per gradient 101: 5 level per gradient 100: 4 level per gradient 011: 3 level per gradient 010: 2 level per gradient 001: 1 level per gradient 000: 8 level per gradient
3:0	W	Window 7 color index in 16-color LUT

Byte 2

default: 00h

Bit	Mode	Function
7	W	Reserved
6	W	Gradient function 0: Disable 1: Enable
5	W	Gradient direction 0: Horizontal 1: Vertical
4	W	Shadow/Border/3D button 0: Disable 1: Enable
3:1	W	Window 7 Type

		000: Shadow Type 1 001: Shadow Type 2 010: Shadow Type3 011: Shadow Type 4 100: 3D Button Type 1 101: 3D Button Type 2 110: Reserved 111: Border
0	W	Window 7 Enable 0: Disable 1: Enable

Realtek Confidential

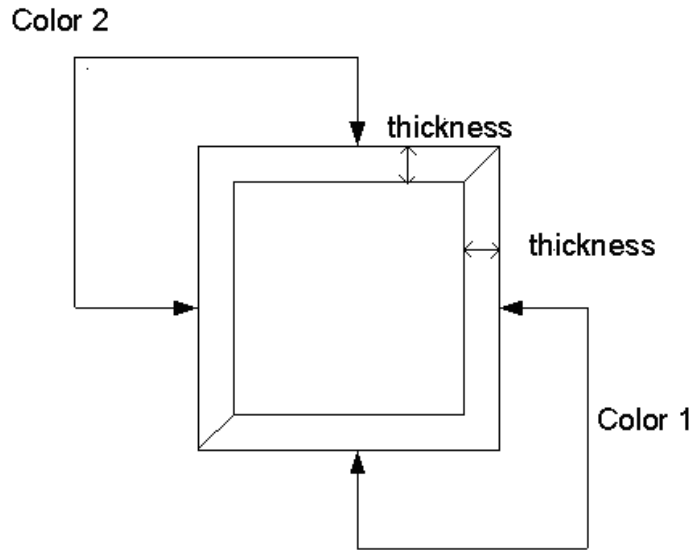

3D Button Type 1

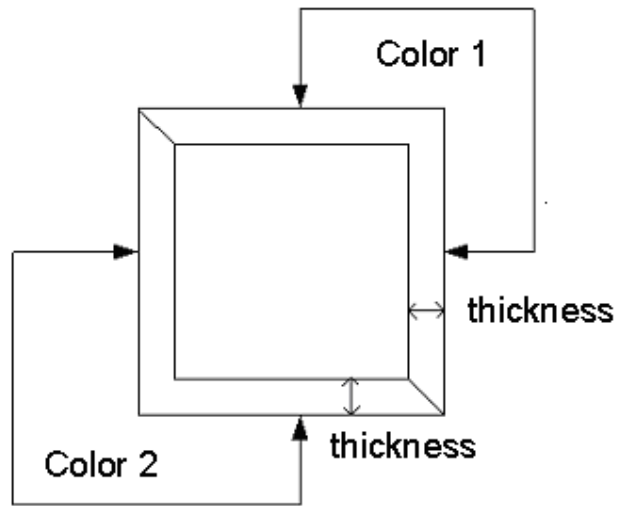

3D Button Type 2

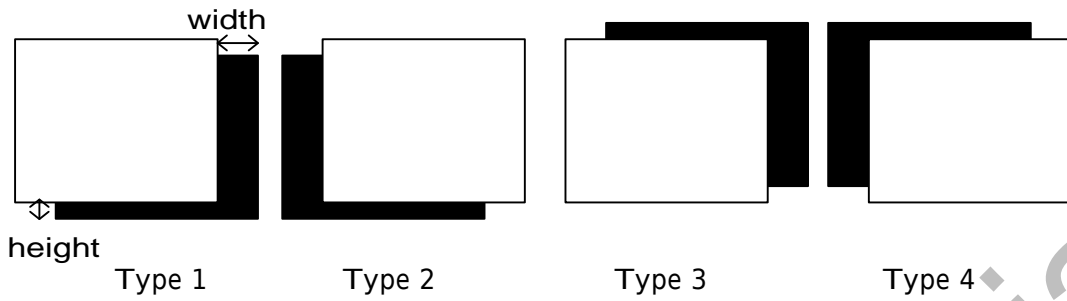

Shadow in all direction

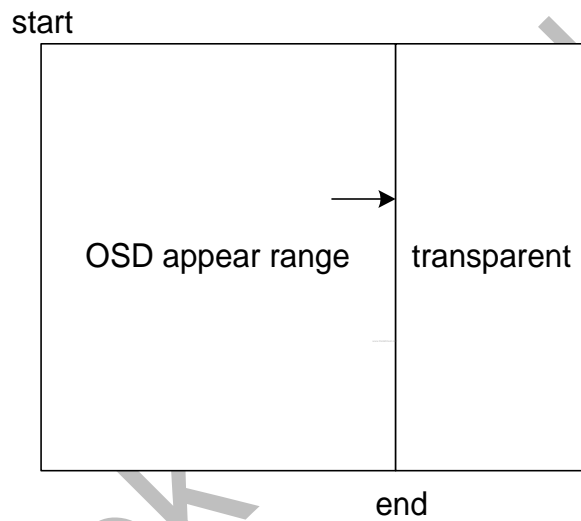

Window mask fade/in out function

Frame control registers
Address: 000h

Byte 0

Bit	Mode	Function
7:0	W	Vertical Delay [10:3] The bits define the vertical starting address. Total 2048 step unit: 1 line

Vertical delay minimum should set 1

Byte 1

Bit	Mode	Function
7:0	W	Horizontal Delay [9:2] The bits define the horizontal starting address. Total 1024 step unit:4 pixels

Horizontal delay minimum should set 2

Byte 2

Bit	Mode	Function
7:6	W	Horizontal Delay bit [1:0]
5:3	W	Vertical Delay [2:0]
2:1	W	Display zone, for smaller character width 00: middle 01: left 10: right 11: reserved
0	W	OSD enable 0: OSD circuit is inactivated 1: OSD circuit is activated

When OSD is disabled, Double Width (address 0x002 Byte1[1]) must be disabled to save power.

PWM Duty Width
Address: 001h

Byte 0

Default: 00h

Bit	Mode	Function
7:0	W	PWM_0 8bits decides the output duty width and waveform of PWM at PWM channel

Byte 1

Default: 00h

Bit	Mode	Function
7:0	W	PWM_1 8bits decides the output duty width and waveform of PWM at PWM channel

Byte 2

Default: 00h

Bit	Mode	Function
7:0	W	PWM_2 8bits decides the output duty width and waveform of PWM at PWM channel

Address: 002h

Byte 0

Default: 00h

Bit	Mode	Function
7:0	W	First stage clock divider N[7:0] $N=0-255, 1^{st} F= F/2(N+1)$

Byte 1

Default: 00h

Bit	Mode	Function
7	W	PWM0 First stage clock divider Enable 0: Disable 1: Enable
6	W	PWM1 First stage clock divider Enable 0: Disable 1: Enable
5	W	PWM2 First stage clock divider Enable 0: Disable 1: Enable
4	W	Enable PWM Output
3:2	W	Crystal Clock Divider 00: Crystal 01: Crystal/2

		10: Crystal/4 11: Crystal/8
1:0	--	Reserved

Byte 2

Default: 00h

Bit	Mode	Function
7:0	--	Reserved

Address: 003h

Byte 0

default: xxxx_xxx0b

Bit	Mode	Function
7	--	Reserved
6	W	Enable Window 7 Mask OSD-Appear-Range Control for Fade In/Out
5	W	Window 7 Mask 0: Mask area appears 1: Mask area transparent
4	W	OSD vertical start input signal source select 0: Select DVS as OSD VSYNC input 1: Select ENA as OSD VSYNC input
3:0	--	Reserved

Byte 1

Bit	Mode	Function
7:4	W	Char shadow/border color
3: 2	W	Alpha Blending Type 00: Disable alpha blending 01: Only window blending 10: All blending 11: Window and Character background blending
1	W	Double width enable (For all OSD including windows and characters) 0: Normal 1: Double
0	W	Double Height enable (For all OSD including windows and characters) 0: Normal 1: Double

Byte 2

Bit	Mode	Function
7:6	W	Font downloaded swap control 0x: No swap

		10: CCW 11: CW
5:2	--	Reserved
1	W	Global Blinking Enable 0: Disable 1: Enable
0	W	Rotation 0: Normal (data latch 24 bit per 24 bit) 1: Rotation (data latch 18 bit per 24 bit)

Bit	7	6	5	4	3	2	1	0
Firmware	A	B	C	D	E	F	G	H
CW	A	E	B	F	C	G	D	H
CCW	E	A	F	B	G	C	H	D

Realtek Confidential

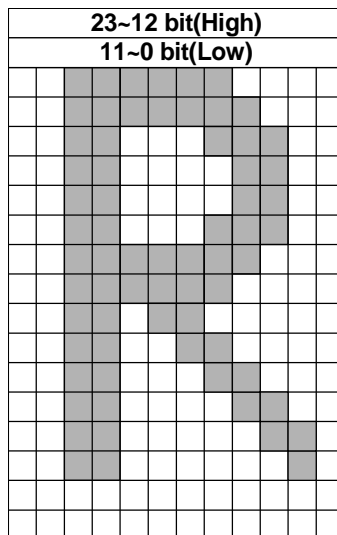

Figure 3 Non-rotated memory alignments

23

6

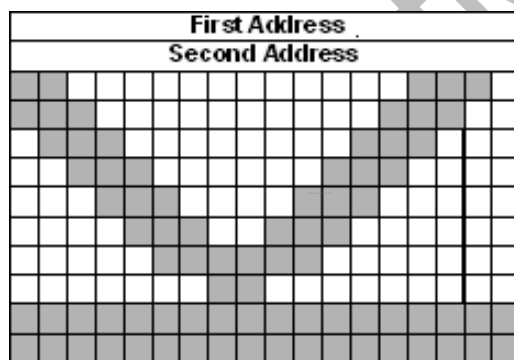

Figure 4 Rotated memory alignments

Base address offset

Address: 004h

Byte 0

Bit	Mode	Function
7:0	W	Font Select Base Address[7:0]

Byte 1

Bit	Mode	Function
7:4	W	Font Select Base Address[11:8]
3:0	W	Font Base Address[3:0]

Byte 2

Bit	Mode	Function
7:0	W	Font Base Address[11:4]

OSD SRAM (Map and font registers)

R0	R1	R2		Rn	End		
C01	C02	B03	C04	...	C11	C12	C13	...
...								
...								
...		Cn1	Cn2	...	1-bit font start		...	
...								
...		2-bit font start		...				
...								
4-bit font start			...					
...								
...								

11.25k bytes SRAM
1. Row Command

R0	R1	R2	R3	R....	Rn	End
----	----	----	----	-------	----	-----

Row Command R0~Rn represent the start of new row. Each command contains 3 bytes data which define the length of a row and other attributes. OSD End Command represents the end of OSD. R0 is set in address 0 of SRAM.

2. Character/Blank Command (Font Select)

Character Command is used to select which character font is show. Each command contains three bytes which specify its attribute and 1,2 or 4bit per pixel. Blank Command represents blank pixel to separate the preceding character and following character. Use two or more Blank Command if the character distance exceeds 255 pixel.

The Font Select Base Address in Frame Control Register represents the address of the first character in Row 0, that is, C01 in the above figure. The following character/blank is write in the next address. C11 represents the first character in Row1, C12 represents the second character in Row1, and so on.

The address of the first character Cn1 in Row n = Font Select Base Address + Row 0 font base length + Row 1 font base length + ...+Row n-1 font base length.

3. Font

User fonts are stored as bit map data. For normal font, one font has 12x18 pixel, and for rotation font, one has 18x12 pixel. One pixel use 1, 2 or 4 bits.

For 12x18 font,

One 1-bit font requires $9 * 24$ bit SRAM

One 2-bit font requires $18 * 24$ bit SRAM

One 4-bit font requires $36 * 24$ bit SRAM

For 18x12 font,

One 1-bit font requires $12 * 24$ bit SRAM

One 2-bit font requires $24 * 24$ bit SRAM

One 4-bit font requires $48 * 24$ bit SRAM

Font Base Address in Frame Control Register point to the start of 1-bit font.

For normal (12x18) font:

1-bit Font, if CS = 128, Real Address of Font = Font Base Address + $9 * 128$

2-bit Font, if CS = 128, Real Address of Font = Font Base Address + $18 * 128$

4-bit Font, if CS = 128, Real Address of Font = Font Base Address + $36 * 128$

For rotational (18x12) font:

1-bit Font, if CS = 128, Real Address of Font = Font Base Address + $12 * 128$

2-bit Font, if CS = 128, Real Address of Font = Font Base Address + $24 * 128$

4-bit Font, if CS = 128, Real Address of Font = Font Base Address + $48 * 128$

where CS is Character Selector in Character Command.

Note that Row Command, Font Select and Font share the same OSD SRAM.

When we download the font, we have to set the Frame control 002h byte1 [1:0] to set the method of hardware bit swap.

If the OSD is Counter-Clock-Wise rotated, we have to set to 0x01 (the 8 bits of every byte of font SRAM downloaded

by firmware will be in a sequence of "7 5 3 1 6 4 2 0" (from MSB to LSB) and should be rearranged to "7 6 5 4 3 2 1 0" by hardware). If it is Clock-Wise rotated, we have to set to 0x10 (the 8 bits of every byte of font SRAM

downloaded by firmware will be in a sequence of "6 4 2 0 7 5 3 1" (from MSB to LSB) and should be rearranged to "7 6 5 4 3 2 1 0" by hardware). After we finish the downloading or if we don't have to rotate the OSD, we have to set

it to 0x00.

Row Command

Byte 0

Bit	Mode	Function
7	W	1: Row Start Command 0: OSD End Command Each row must start with row-command, last word of OSD map must be end-command
6:5	W	Reserved
4:2	W	Character border/shadow 000: None 001: Border 100: Shadow (left-top) 101: Shadow (left-bottom) 110: Shadow (right-top) 111: Shadow (right-bottom)
1	W	Double character width 0: x1 1: x2
0	W	Double character height 0: x1 1: x2

Byte 1

Bit	Mode	Function
7:3	W	Row height (1~32)
2:0	W	Column space 0~7 pixel column space When Char is doubled, so is column space.

Notice:

When character height/width is doubled, the row height/column space definition also twice. If the row height is larger than character height, the effect is just like space between rows. If it is smaller than character height, it will drop last several bottom line of character.

When using 1/2/4LUT font, column space and font smaller than row height, the color of column space and row space is the same as font background color, only 4 bit true color font mode, the color is transparent

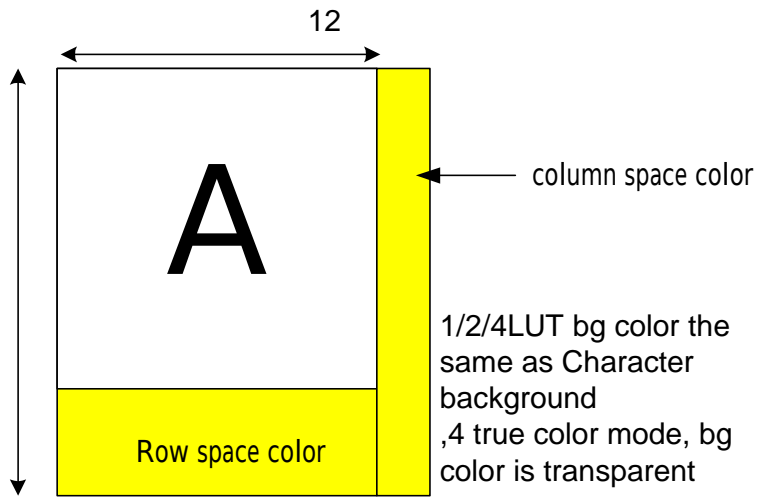

Byte 2

Bit	Mode	Function
7:0	W	Row length unit: font base

Character Command (For blank)

Byte 0

Bit	Mode	Function
7	W	0
6	W	Blinking effect 0: Disable 1: Enable
5:0	W	Reserved

Byte 1

Bit	Mode	Function
7:0	W	Blank pixel length

At least 3 pixels, and can't exceed 255 pixels.

Byte 2

Bit	Mode	Function
7:5	W	Reserved
4	W	Reserved
3:0	W	Blank color – select one of 16-color LUT (0 is special for transparent)

Character Command (For 1-bit RAM font)

Byte 0

Bit	Mode	Function
7	W	1
6	W	Character Blinking effect 0: Disable 1: Enable
5:4	W	00 (Font type 00: 1-bit RAM Font 01: 4-bit RAM Font 1x: 2-bit RAM Font)
3:0	W	Character width (only for 1-pixel font, doubled when specifying double-width in Row/Blank command register) For 12x18 font: 0100: 4-pixel 0101: 5-pixel 0110: 6-pixel 0111: 7-pixel 1000: 8-pixel 1001: 9-pixel 1010: 10-pixel 1011: 11-pixel 1100: 12-pixel For 18x12 Font (rotated) 0000: 4-pixel 0001: 5-pixel 0010: 6-pixel 0011: 7-pixel 0100: 8-pixel 0101: 9-pixel 0110: 10-pixel 0111: 11-pixel 1000: 12-pixel 1001: 13-pixel 1010: 14-pixel 1011: 15-pixel 1100: 16-pixel 1101: 17-pixel 1110: 18-pixel

When using border/shadow/ effect, the width of the 1-bit font should at least 6 pixel.

Byte 1

Bit	Mode	Function
7:0	W	Character Select [7:0]

Byte 2

Bit	Mode	Function
7:4	W	Foreground color Select one of 16-color from color LUT
3:0	W	Background color Select one of 16-color from color LUT (0 is special for transparent)

Character command (For 2-bit RAM Font)

Byte 0

Bit	Mode	Function
7	W	1
6	W	MSB of Foreground color 11, Background 00
5	W	1
4	W	MSB of Foreground color 10, Foreground 01
3:1	W	Foreground color 11 Select one of 8 color from color LUT Add Byte0 [6] as MSB for 16-color LUT.
0	W	Background color 00 Bit[2] Select one of 8 color from color LUT

Byte 1

Bit	Mode	Function
7:0	W	Character Select [7:0]

Byte 2

Bit	Mode	Function
7:6	W	Background color 00 Bit[1:0] Select one of 8 color from color LUT While 0 is special for transparent Add Byte0 [6] as MSB for 16-color LUT. Once we fill 0000 or 1000(MSB follow Byte0[6]), BG appears transparent.
5:3	W	Foreground color 10 Select one of 8 color from color LUT Add Byte0 [4] as MSB for 16-color LUT.
2:0	W	Foreground color 01 Select one of 8 color from color LUT Add Byte0 [4] as MSB for 16-color LUT.

Character command (For 4-bit RAM font)

Byte 0

Bit	Mode	Function
7	W	1
6	W	Character Blinking effect 0: Disable 1: Enable
5:4	W	01

		(Font type 00: 1-bit RAM Font 01: 4-bit RAM Font 1x: 2-bit RAM Font)
3:0	W	(for Byte1[7] = 0) select one color from 16-color LUT as background (for Byte1[7] = 1) Red color level MSB 4 bits for 8 bits color level (LSB 4 bits are 1111)

Byte 1

Bit	Mode	Function
7	W	0: 4bit Look Up Table, 0000'b is transparent. 1: 3bit specify R,G,B pattern, color level defined in Byte0[3:0],Byte2. One mask bit defines foreground or background.
6:0	W	Character Select [6:0]

- ! When 4-bit look-up table mode , color of column space is the same as background.
- ! When 4-bit look-up table mode and pixel value is 0000, and byte0[3:0]=0000 means transparent.
- ! When true color mode and pixel value is 0000 , it is transparent .

Byte 2

Bit	Mode	Function
7:4	W	(for Byte1[7] = 1) Green color level MSB 4 bits for 8 bits color level (LSB 4 bits are 1111)
3:0	W	(for Byte1[7] = 1) Blue color level MSB 4 bits for 8 bits color level (LSB 4 bits are 1111)

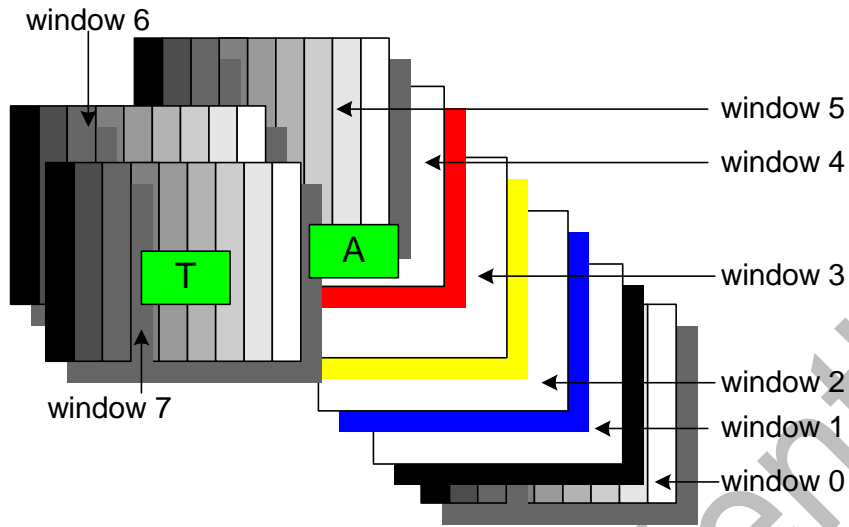

Display Priority

We have four windows with gradient and four windows without gradient, the window priority is as above, character should be always on the top layer of the window.

Pattern gen.

Use OSD to replace display pattern generator.

Chess Board: make a font as below

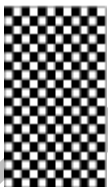

If we want to fill to the full 1280x1024 screen with character, we need 1280*1024 pixels.

Required character is:

Using 12*18 font

$$1280/12 = 106.7 \rightarrow 107$$

$$1024/18 = 56.9 \rightarrow 57$$

$$107*57 = 6099 \text{ character}$$

The required number of character map is larger than RAM size. We must turn on double width or double height function to reduce the half of character map.

So the basic unit to chessboard is 2x2 pixel. You can use larger chessboard instead of 2x2 pixels unit, such as 4x4 and so on.

Gray level

We can display 256 gray level by gradient window, 8 and 16 gray level by character map. 32 and 64 gray level is not supported.

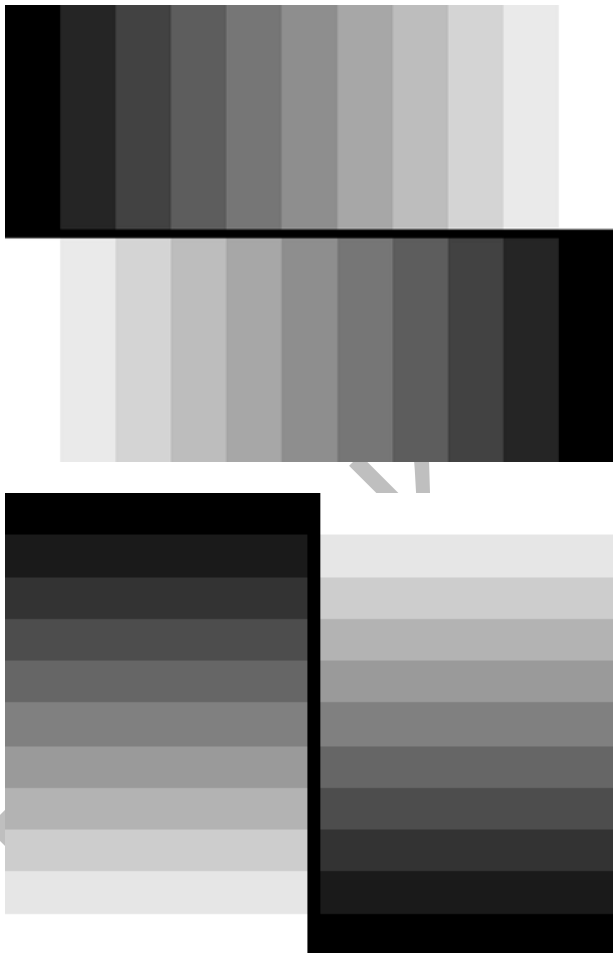

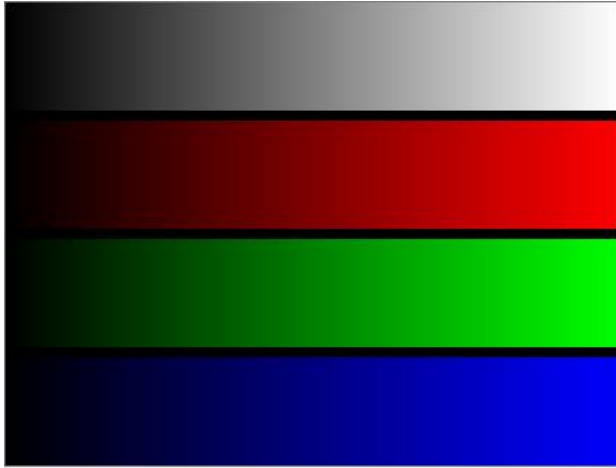

Realtek Confidential

6. Electric Specification

DC Characteristics

Absolute Maximum Ratings

PARAMETER	SYMBOL	MIN	TYP	MAX	UNITS
Electrostatic Discharge	V _{ESD}			±3.0	kV
Latch-Up	I _{LA}			±100	mA
Ambient Operating Temperature	T _A	0		70	°C
Storage temperature (plastic)	T _{STG}	-55		125	°C
Thermal Resistance (Junction to Air)	θ _{JA}			35	°C/W

DC Characteristics/Operating Condition

(0°C < T_A < 70°C; VDD = 3.3V ± 0.3V)

PARAMETER	SYMBOL	MIN	TYP	MAX	UNITS
Supply Voltage	VDD	3.0	3.3	3.6	V
Supply Current(All function on at 135M)					mA
• Digital Power	I _{DVCC}		140(LVDS)	170(RSDS)	
• ADC Power	I _{ADC_VDD}		78(UXGA)		
• PLL Power	I _{PLL_VDD}		48(UXGA)		
• Pad Power	I _{PVCC}		80	104	
• TMDS Power	I _{TMDS_VDD}		146		
Supply Current(Power Saving)					mA
• Digital Power	I _{DVCC}		4		
• ADC Power	I _{ADC_VDD}		3		
• PLL Power	I _{PLL_VDD}		1.45		
• Pad Power	I _{PVCC}		4		
• TMDS Power	I _{TMDS_VDD}		0.48		
Output High Voltage	V _{OH}	2.4		VDD	V
Output Low Voltage	V _{OL}	GND		0.5	V
Input High Voltage	V _{IH}	2.0			V
Input Low Voltage	V _{IL}			0.8	V

7. Mechanical Specification

128 Pin Package

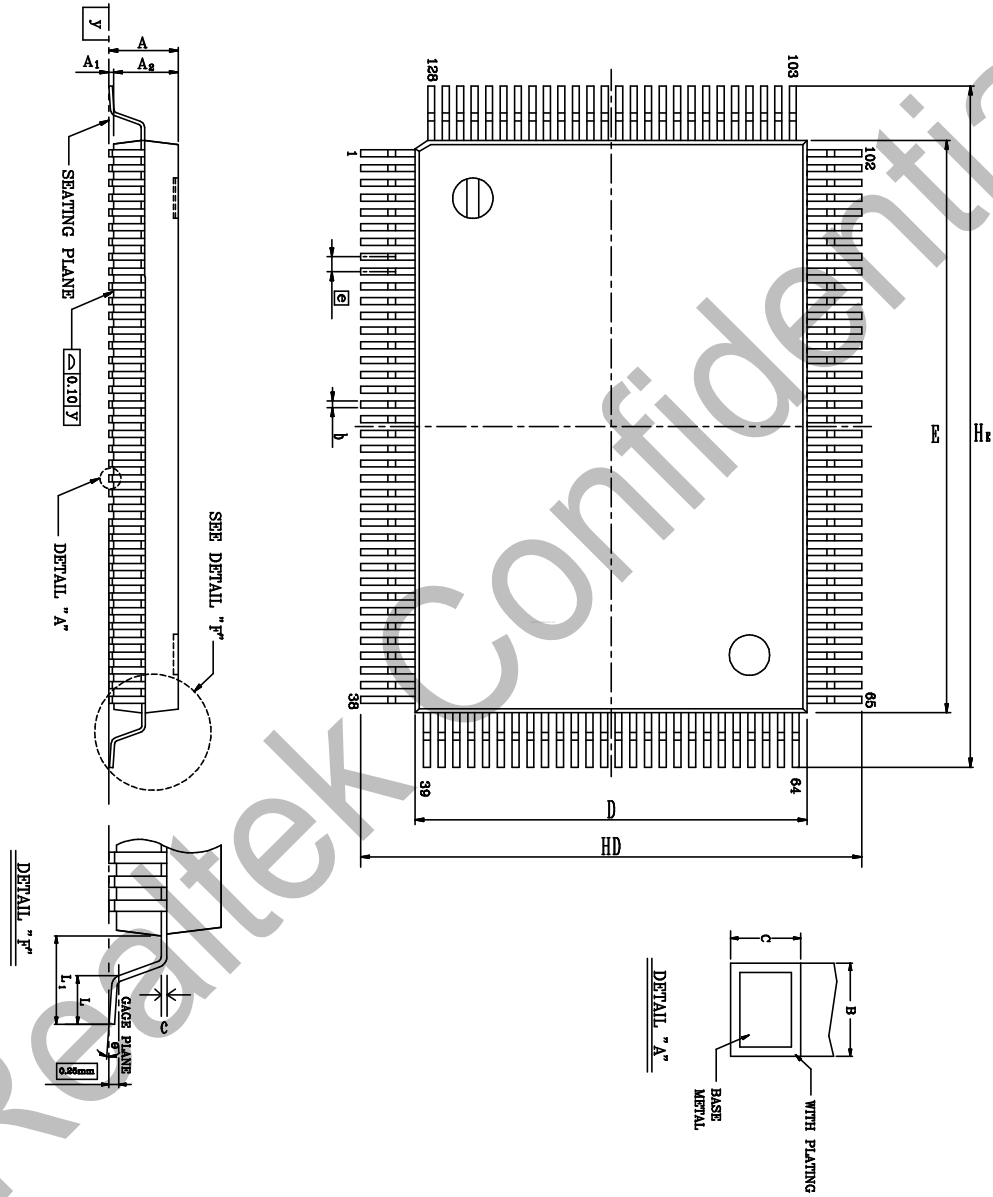

Note:

Symbol	Dimension in inch			Dimension in mm		
	Min	Type	Max	Min	Type	Max
A	—		0.134	—	—	3.40
A ₁	0.004	0.010	0.036	0.10	0.25	0.91
A ₂	0.102	0.112	0.122	2.60	2.85	3.10
b	0.005	0.009	0.013	0.12	0.22	0.32
c	0.002	0.006	0.010	0.05	0.15	0.25
D	0.541	0.551	0.561	13.75	14.00	14.25
E	0.778	0.787	0.797	19.75	20.00	20.25
e	0.010	0.020	0.030	0.25	0.5	0.75
H _b	0.665	0.677	0.689	16.90	17.20	17.50
H _E	0.902	0.913	0.925	22.90	23.20	23.50
L	0.027	0.035	0.043	0.68	0.88	1.08
L ₁	0.053	0.063	0.073	1.35	1.60	1.85
y	—	—	0.004	—	—	0.10
θ	0°	—	12°	0°	—	12°

1.Dimension D & E do not include interlead flash

2. Dimension b does not include dambar protrusion/intrusion.

3.Controlling dimension: Millimeter

4.General appearance spec. should be based on final visual insp

TITLE : 128LD QFP (14x20 mm ²) PACKAGE OUTLINE -CU L/F, FOOTPRINT 3.2 mm			
LEADFRAME		MATERIAL:	
APPROVE		DOC. NO.	530-ASS-P004
		VERSION	1
		PAGE	OF
CHECK		DWG NO.	Q128 - 1
		DATE	MAR. 25.1997
REALTEK SEMI-CONDUCTOR CO., LTD			

Realtek Confidential

8. Ordering Information

The available RTD2523B series pin compatible products listed below:

Part Number	ADC	DVI	HDCP	Resolution	Output	Package
RTD2523B	160MHz	Yes	No	SXGA	LVDS/RSDS/TTL	128 QFP
RTD2513B	110MHz	Yes	No	XGA	LVDS/RSDS/TTL	128 QFP
RTD2023B	160MHz	No	No	SXGA	LVDS/RSDS/TTL	128 QFP
RTD2013B	110MHz	No	No	XGA	LVDS/RSDS/TTL	128 QFP
RTD2523BH	160MHz	Yes	Yes	SXGA	LVDS/RSDS/TTL	128 QFP
RTD2513BH	110MHz	Yes	Yes	XGA	LVDS/RSDS/TTL	128 QFP
RTD2523B-LF*	160MHz	Yes	No	SXGA	LVDS/RSDS/TTL	128 QFP (lead free)
RTD2513B-LF*	110MHz	Yes	No	XGA	LVDS/RSDS/TTL	128 QFP (lead free)
RTD2023B-LF*	160MHz	No	No	SXGA	LVDS/RSDS/TTL	128 QFP (lead free)
RTD2013B-LF*	110MHz	No	No	XGA	LVDS/RSDS/TTL	128 QFP (lead free)
RTD2523BH-LF*	160MHz	Yes	Yes	SXGA	LVDS/RSDS/TTL	128 QFP (lead free)
RTD2513BH-LF*	110MHz	Yes	Yes	XGA	LVDS/RSDS/TTL	128 QFP (lead free)

* lead free and green package are available for above items with suffix –LF or –GR respectively.