



LM317M

LINEAR INTEGRATED CIRCUIT

MEDIUM CURRENT 1.2V TO 37V ADJUSTABLE VOLTAGE REGULATOR

DESCRIPTION

The UTC **LM317M** is an adjustable 3-terminal positive voltage regulator, designed to supply 500mA of output current with voltage adjustable from 1.2V ~ 37V.

FEATURES

- *Output Voltage Adjustable From 1.2V ~ 37V
- *Output Current In Excess of 500mA
- *Internal Thermal Overload Protection
- *Internal Short Circuit Current Limiting
- *Output Transistor Safe Area Compensation

ORDERING INFORMATION

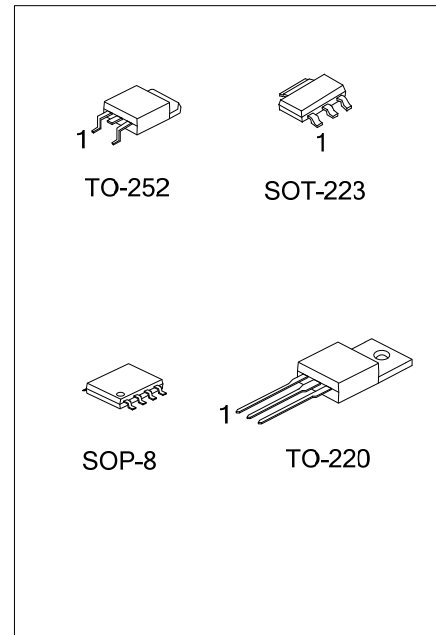

Ordering Number		Package	Pin Assignment								Packing
Lead Free	Halogen Free		1	2	3	4	5	6	7	8	
LM317ML-AA3-R	LM317MG-AA3-R	SOT-223	ADJ	O	I	-	-	-	-	-	Tape Reel
LM317ML-S08-R	LM317MG-S08-R	SOP-8	I	O	O	ADJ	x	O	O	x	Tape Reel
LM317ML-S08-T	LM317MG-S08-T	SOP-8	I	O	O	ADJ	x	O	O	x	Tube
LM317ML-TA3-T	LM317MG-TA3-T	TO-220	ADJ	O	I	-	-	-	-	-	Tube
LM317ML-TN3-R	LM317MG-TN3-R	TO-252	ADJ	O	I	-	-	-	-	-	Tape Reel
LM317ML-TN3-T	LM317MG-TN3-T	TO-252	ADJ	O	I	-	-	-	-	-	Tube

Note: Pin Assignment: I:V_{IN} O:V_{OUT} x: NC

<p>LM317ML-AA3-R</p> <p>(1)Packing Type (2)Package Type (3)Lead Free</p>	<p>(1) R: Tape Reel, T: Tube (2) AA3: SOT-223, TA3: TO-220, TN3: TO-252, S08: SOP-8 (3) G: Halogen Free, L: Lead Free</p>
--	---

■ BLOCK DIAGRAM

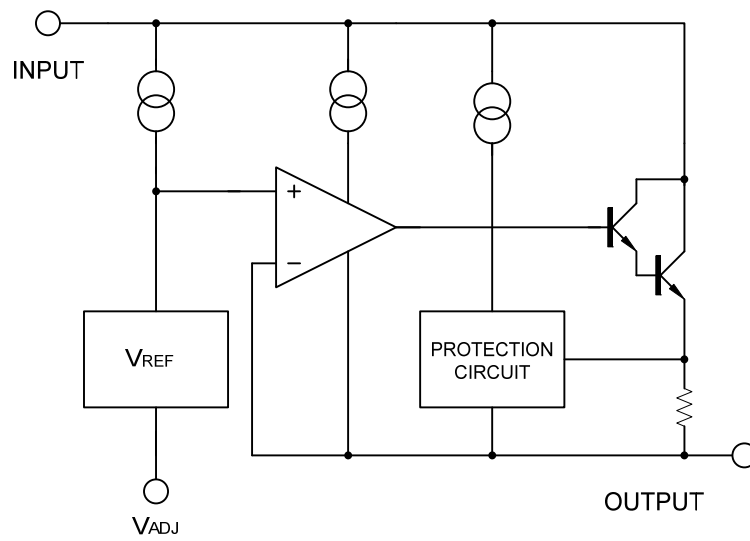

■ ABSOLUTE MAXIMUM RATINGS

PARAMETER	SYMBOL	RATINGS	UNIT
Input-Output Voltage Differential	$V_{IN}-V_{OUT}$	40	V
Power Dissipation	P_D	Internally Limited	W
Junction Temperature	T_J	+125	°C
Operating Temperature	T_{OPR}	-40 ~ +85	°C
Storage Temperature	T_{STG}	-40 ~ +150	°C

Note: Absolute maximum ratings are those values beyond which the device could be permanently damaged.

Absolute maximum ratings are stress ratings only and functional device operation is not implied.

■ THERMAL DATA

PARAMETER	SYMBOL	RATINGS	UNIT	
Junction to Ambient	θ_{JA}	SOT-223	150	°C/W
		SOP-8	165	
		TO-220	70	
		TO-252	92	
Junction to Case	θ_{JC}	SOT-223	15	°C/W
		SOP-8	20	
		TO-220	5	
		TO-252	5	

■ ELECTRICAL CHARACTERISTICS

($V_{IN}-V_{OUT}=5V$, $I_{OUT}=0.1A$, $T_A=25^\circ C$, unless otherwise specified.)

PARAMETER	SYMBOL	TEST CONDITIONS	MIN	TYP	MAX	UNIT	
Line Regulation	$\Delta V_{OUT}/V_{OUT}$	$3V \leq V_{IN}-V_{OUT} \leq 40V$		0.01	0.04	%/V	
Load Regulation	ΔV_{OUT}	$10mA \leq I_{OUT} \leq 0.5A$		$V_{OUT} \leq 5V$	5	25	mV
				$V_{OUT} \geq 5V$	0.1	0.5	%
Adjustable Pin Current	I_{ADJ}			50	100	μA	
Adjustable Pin Current Change	ΔI_{ADJ}	$3V \leq V_{IN}-V_{OUT} \leq 40V$, $10mA \leq I_{OUT} \leq 0.5A$, $P_D < 7.5W$		0.2	5	μA	
Reference Voltage	V_{REF}	$3V \leq V_{IN}-V_{OUT} \leq 40V$, $10mA \leq I_{OUT} \leq 0.5A$, $P_D < 7.5W$	1.20	1.25	1.30	V	
Temperature Stability		$T_{MIN} \leq T_J \leq T_{MAX}$		0.7		%/V _{OUT}	
Minimum Load Current for Regulation	$I_{L(MIN)}$	$V_{IN}-V_{OUT}=40V$		3.5	10	mA	
Maximum Output Current	$I_{O(MAX)}$	$V_{IN}-V_{OUT}=40V$, $P_D \leq 7.5W$	0.1	0.2		A	
RMS Noise vs. % of V_{OUT}	eN	$10Hz \leq f \leq 10KHz$		0.003		%/V _{OUT}	
Ripple Rejection	RR	$V_{OUT}=10V, f=120Hz$		$C_{ADJ}=0$	65		dB
				$C_{ADJ}=10\mu F$	66	80	

Note: C_{ADJ} is connected between Adjust pin and Ground.

APPLICATION CIRCUITS

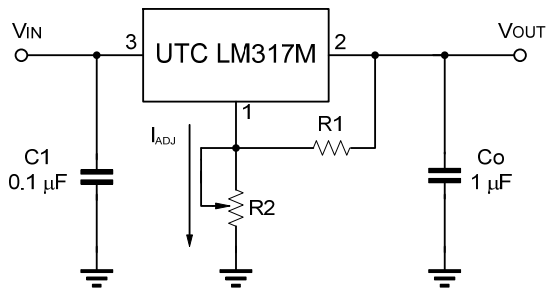

Fig.1 Programmable voltage regulator

$$V_{OUT} = 1.25V \cdot (1 + R2/R1) + I_{ADJ} \cdot R2$$

C1 is required when regulator is located an appreciated distance from power supply. Co is needed to improve transient response.

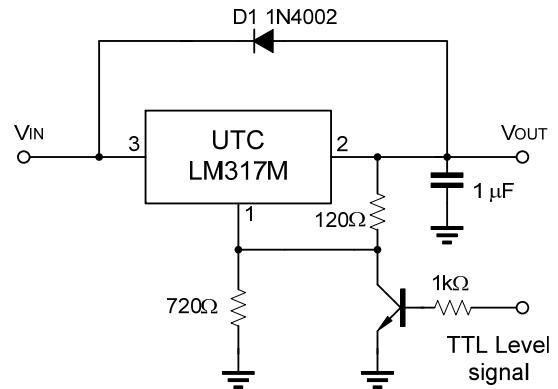

Fig.2 Regulator with On-off control

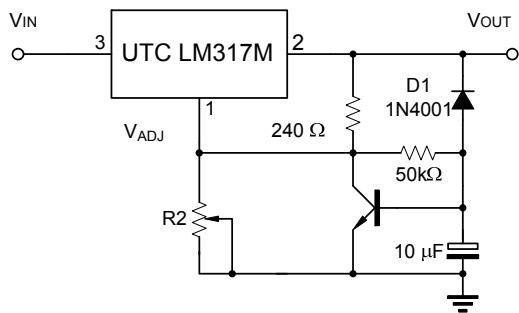
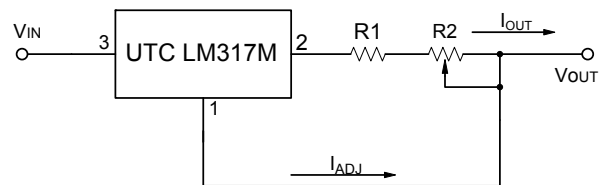

Fig.3 Soft Start Application



$$I_{O(MAX)} = \left(\frac{V_{REF}}{R1} \right) + I_{ADJ} = \frac{1.25V}{R1}$$

$$I_{O(MIN)} = \left(\frac{V_{REF}}{R1+R2} \right) + I_{ADJ} = \frac{1.25V}{R1+R2}$$

$$5mA < I_{OUT} < 100mA$$

Fig.4 Constant Current Application

TYPICAL CHARACTERISTICS

Load Regulation vs. temperature

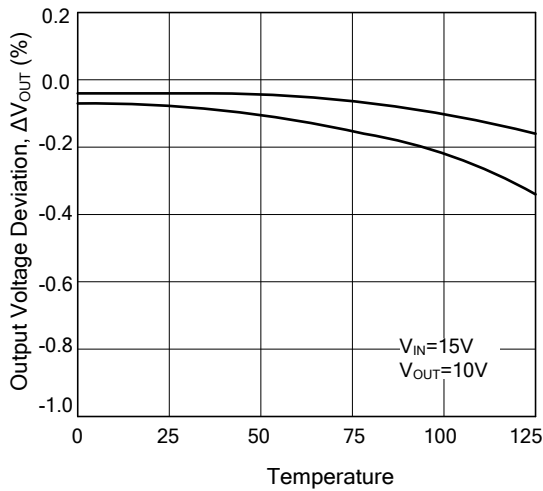

Adjustment Current vs. Temperature

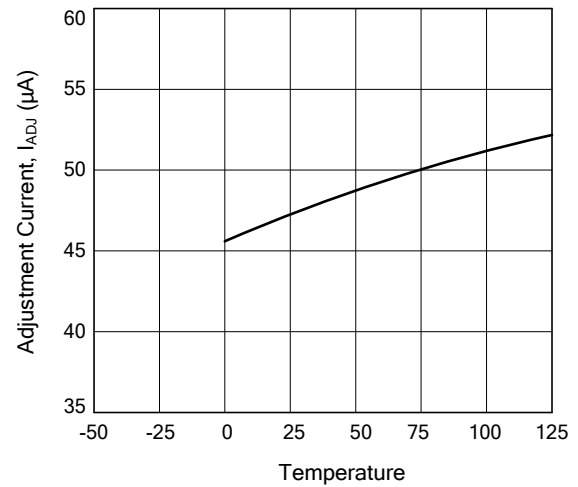

Current Limit

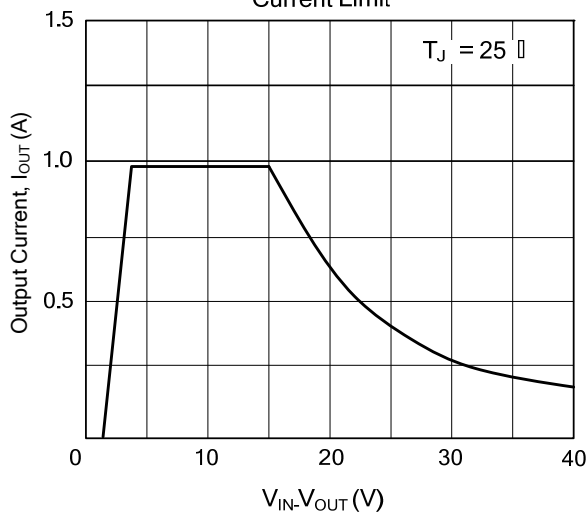

Minimum Operating Current

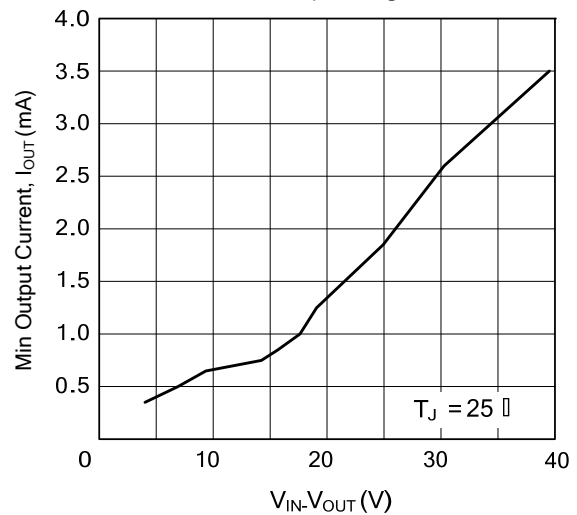

UTC assumes no responsibility for equipment failures that result from using products at values that exceed, even momentarily, rated values (such as maximum ratings, operating condition ranges, or other parameters) listed in products specifications of any and all UTC products described or contained herein. UTC products are not designed for use in life support appliances, devices or systems where malfunction of these products can be reasonably expected to result in personal injury. Reproduction in whole or in part is prohibited without the prior written consent of the copyright owner. The information presented in this document does not form part of any quotation or contract, is believed to be accurate and reliable and may be changed without notice.