

PLEASE CHECK WWW.MOLEX.COM FOR LATEST PART INFORMATION

Part Number: [0340801002](#)
Status: **Active**
Overview: [mx150 sealed connector system](#)
Description: MX150™ Male Cable Seal Terminal, Tin (Sn) Plating, 18-20 AWG, Left Reel Payoff, Contact Material Thickness 0.30mm (.012")

Documents:

[Drawing \(PDF\)](#) [RoHS Certificate of Compliance \(PDF\)](#)

General

Product Family	Crimp Terminals
Series	34080
Comments	Left Reel Payoff
Crimp Quality Equipment	Yes
Overview	mx150 sealed connector system
Product Name	MX150™

Physical

Gender	Male
Material - Metal	High Performance Alloy (HPA)
Material - Plating Mating	Tin
Material - Plating Termination	Tin
Packaging Type	Reel
Plating min: Mating (µin)	20.00
Plating min: Mating (µm)	0.500
Plating min: Termination (µin)	20.00
Plating min: Termination (µm)	0.50
Termination Interface: Style	Crimp or Compression
Wire Insulation Diameter	2.90mm (.114") max.
Wire Size AWG	18, 20
Wire Size mm²	0.75, 1.00

Electrical

Current - Maximum per Contact	22A
Voltage - Maximum	250V

Material Info

Reference - Drawing Numbers

Sales Drawing	AU5T-14421-AA, SD-34080-001
---------------	-----------------------------



image - Reference only

EU RoHS

ELV and RoHS Compliant

REACH SVHC

Contains SVHC: No

Halogen-Free

Status

Halogen-Free

China RoHS



Need more information on product environmental compliance?

Email productcompliance@molex.com
 For a multiple part number RoHS Certificate of Compliance, [click here](#)

Please visit the [Contact Us](#) section for any non-product compliance questions.

Search Parts in this Series

[34080Series](#)

Mates With

[34083](#) MX150™ Female Cable Seal Terminal

Use With

[33471](#) Single Row Sealed Connector, [33472](#) Dual Row Sealed Connector, [33476](#) Dual Row Hybrid Sealed Connector, [34062](#) Single Row 2-Way Cable Sealed Connector, [34250](#) Single Row 3-Way Cable Sealed Connector

Application Tooling | FAQ

Tooling specifications and manuals are found by selecting the products below. Crimp Height Specifications are then contained in the Application Tooling Specification document.

Global

Description

Product #

Hand Crimp Tool For 0638199200
MX150 Cable Seal
Crimp Terminals
Fine Adjust 0639017300
Applicator for
MX150™ Cable Seal
Crimp Terminals

This document was generated on 05/19/2010

PLEASE CHECK WWW.MOLEX.COM FOR LATEST PART INFORMATION

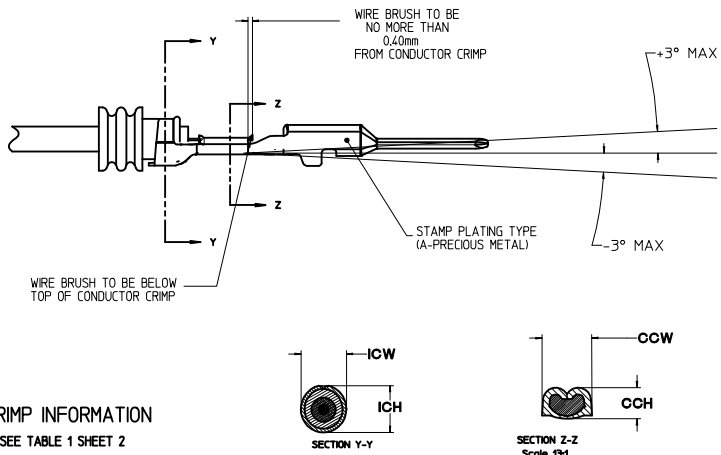

CRIMP INFORMATION
SEE TABLE 1 SHEET 2

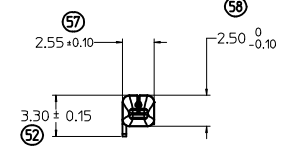
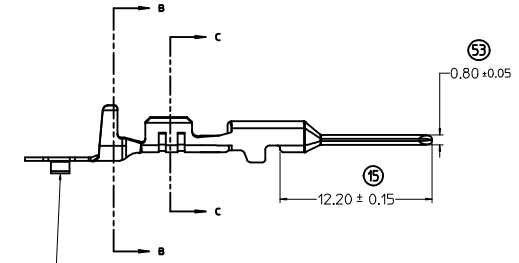
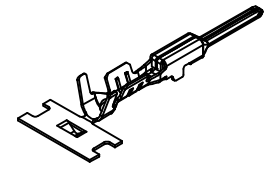
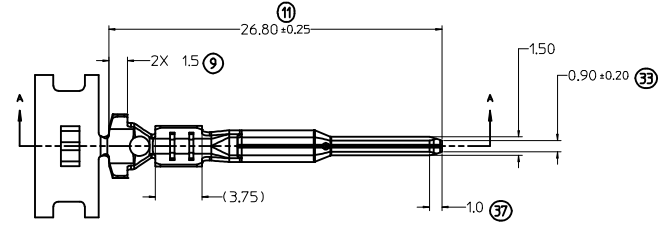

CARRIER BUMP DIRECTION POINTS DOWN FOR TIN PLATED TERMINALS POINTS UP FOR PRECIOUS PLATED TERMINALS

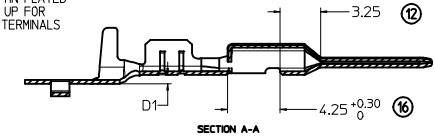

SEE TABLE 2 ON SHEET 3 FOR CHARTED DIM.

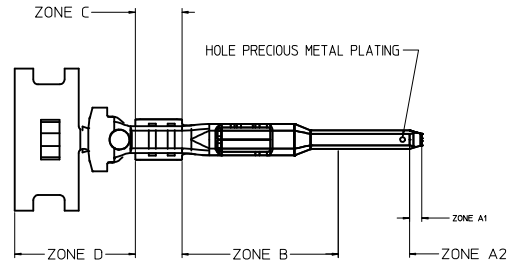

PRECIOUS METAL PLATED BLADE

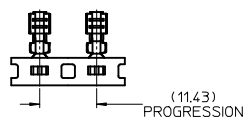

NOTES: (UNLESS OTHERWISE SPECIFIED)

- MATING TERMINAL SHOWN ON SD-34083-002
- MATERIAL: ASTM B422, UNS C19025, HR04
THICKNESS: 0.30 mm ± 0.01
TEMPER: FULL HARD (REF)
TENSILE: 496 MIN MPA
- MEETS PERFORMANCE SPECIFICATION FOR CABLE TO TERMINAL ELECTRICAL CRIMPS PER SAE/USCAR-21 (2/2004)
- MEETS PERFORMANCE STANDARD FOR AUTOMOTIVE ELECTRICAL CONNECTOR SYSTEMS FOR SAE/USCAR-2, REV. 4 (TEMP CLASS 3) (5/2004)
- MEETS ELECTRICAL CONNECTION SYSTEM DESIGN SPECIFICATION (SDS) REV.14 (01/2007)
- MEETS FIELD CORRELATED LIFE TEST (FCLT) PER SAE/USCAR-20 (6/2004)
- REFERENCE FORD CAVITY SPECIFICATION 97BG-14421-ADA,REV. E
- INSERTION FORCE WITH CORRESPONDING FEMALE TERMINAL: AVG. FORCE 3.1 N TIN (REFERENCE) TBD GOLD & SILVER (REFERENCE)
- REFERENCE CRIMP SPECIFICATION (CS-34080-001) FOR ADDITIONAL INFORMATION.
- REFERENCE PK-31300-516 FOR REEL DIRECTION

PLATING NOTES:

- PRECIOUS METAL PLATED TERMINAL:
 - GOLD PLATING
 - UNDERPLATE: OVERALL ELECTRODEPOSITED DUCTILE SULFAMATE NICKEL THICKNESS 1.25 - 2.25 MICROMETERS
 - CONTACT ZONE A2: ELECTRODEPOSITED GOLD THICKNESS 0.76 MICROMETER MINIMUM
 - ZONE A1: REDUCED GOLD THICKNESS FROM ZONE A2 IS PERMITTED ZONE A1 SHALL BE COMPLETELY COVERED WITH NICKEL TO PREVENT EXPOSED BASE METAL
 - ZONE B: REDUCED GOLD THICKNESS FROM ZONE C IS PERMITTED ZONE B SHALL BE COMPLETELY COVERED WITH NICKEL TO PREVENT EXPOSED BASE METAL
 - ZONE C: TIN PLATING; ELECTRODEPOSITED TIN (100% TIN), MATTE FINISH THICKNESS 2.50 - 4.00 MICROMETERS
 - ZONE D: REDUCED TIN THICKNESS FROM ZONE C IS PERMITTED ZONE D SHALL BE COMPLETELY COVERED WITH NICKEL TO PREVENT EXPOSED BASE METAL
 - SILVER PLATING
 - UNDERPLATE: OVERALL ELECTRODEPOSITED DUCTILE SULFAMATE NICKEL 1.25 - 2.25 MICROMETERS THICK
 - ZONE A2: ELECTRODEPOSITED PURE SILVER (0.5 PERCENT MAX IMPURITIES) SEMI-BRIGHT FINISH 1.9 - 3.3 MICROMETERS THICK OVER NICKEL
 - ANTI-TARNISH TREATMENT TO SILVER ZONES: EVABRITE S
 - ZONE A1: REDUCED SILVER PLATING THICKNESS FROM ZONE A2 IS PERMITTED OVER NICKEL
 - ZONE B: REDUCED SILVER PLATING THICKNESS FROM ZONE A2 AND REDUCED TIN PLATING THICKNESS FROM ZONE C IS PERMITTED OVER NICKEL
 - ZONE C: ELECTRODEPOSITED TIN (100% TIN) MATTE FINISH 2.5 - 4.00 MICROMETERS THICK OVER NICKEL
 - ZONE D: REDUCED TIN PLATING THICKNESS FROM ZONE C IS PERMITTED OVER NICKEL
- TIN PLATING
 - UNDERPLATE: ADVANCED BARRIER LAYER THICKNESS 0.25 - 1.00 MICROMETERS
 - TIN LAYER: ELECTRODEPOSITED REFLOW TIN (100% TIN) THICKNESS 0.50 - 1.00 MICROMETERS

LTRS.		REVISIONS	
ORIGINATOR	CHECKER	ENGR	APPROVAL APP
RELEASED			
A	AELE-E11776560-199 DATE: 20080708		
KFERGUSON ADHIR		GLEECE	
B1 ADD GOLD AND SILVER PART NUMBERS TO TABLES 1 AND 2 RELEASED: BUST-14421-AA BUST-14421-BA BUST-14421-CA BUST-14421-DA BUST-14421-EA BUST-14421-FA			
B2 MOVE CRIMP TOOL INFORMATION AND TABLE 2 ON SHEET 3			
B3 ADD GOLD AND SILVER PLATING NOTES AELE-E-11776560-276 DATE: 20090610			
KFERGUSON ADHIR		GLEECE	
FORD PART NO.		REFERENCE	
AUST-14421-AA		---	
AUST-14421-BA		PART MUST COMPLY WITH MATERIAL SPECIFICATION MSB-MSB999-41 TO HELP PASSENGER HEALTH, SAFETY AND THE ENVIRONMENT.	
AUST-14421-CA		DRAFTED IN ACCORDANCE WITH F40 ENGINEERING DRAFTING STANDARD	
AUST-14421-AA		CURRENT AT INITIAL RELEASE	
AUST-14421-BA		CAD TYPE CAD LOC CAD FILE	
AUST-14421-CA		IS MASTER	
AUST-14421-DA		OPER. NO. UNIT DRAWING	
AUST-14421-EA		AUST-14421-AA	
AUST-14421-FA		DESIGN DETAIL TITLE	
---		BNT 1 OF 3	
KFERGUSON		SAFETY	
---		TERMINAL WIRE SNAP ON MALE	
AUST-14421-DA		SCALE	
AUST-14421-EA		DATE DIVISION	
AUST-14421-FA		7/1 2008/07/08 PLANT	

DIM. SIZE: A0

TABLE 1 - TERMINAL CRIMP DIMENSION REFERENCE TABLE

FORD PART NO.	SUPPLIER PART NO.		PLATING	WIRE SIZE (AWG)	SPECIFICATION WIRE	CONDUCTOR CCH(SEC Z-Z) ±0.05	CONDUCTOR CCW(SEC Z-Z) ±0.10	INSULATOR ICH(SEC Y-Y) ±0.10	INSULATOR ICW(SEC Y-Y) ±0.10	FORD CABLE SEAL PART NO.
	RIGHT PAYOFF	LEFT PAYOFF								
AU5T-14421-CA	34080-0001	34080-1001	TIN	14	M1L-123A	1.65	2.45	3.95	3.65	XW4T-14603-MA
					M1L-135A1	1.65	2.45	3.80	3.65	XW4T-14603-FA
					M1L-123A	1.35	2.45	3.80	3.65	XW4T-14603-FA
AU5T-14421-BA	34080-0002	34080-1002	TIN	18	M1L-123A	1.25	2.15	3.70	3.55	XW4T-14603-AA
					M1L-123A	1.15	2.15	3.60	3.55	XW4T-14603-AA
					M1L-123A	1.00	1.60	3.50	3.45	97BG-10C930-SBA
AU5T-14421-AA	34080-0003	34080-1003	TIN	22	M1L-123A	1.00	1.60	3.50	3.45	97BG-10C930-SBA
AU5T-14421-CA	34080-0001	34080-1001	TIN	2.00mm ²	JASO D 611(AVSS)	1.60	2.45	3.95	3.65	XW4T-14603-MA
AU5T-14421-CA	34080-0001	34080-1001	TIN	1.50mm ²	M1L-126A1	1.40	2.45	3.80	3.65	XW4T-14603-FA
AU5T-14421-BA	34080-0002	34080-1002	TIN	1.00mm ²	M1L-126A1	1.30	2.15	3.70	3.55	XW4T-14603-AA
				0.75mm ²	M1L-126A1	1.25	2.15	3.60	3.55	XW4T-14603-AA
AU5T-14421-AA	34080-0003	34080-1003	TIN	0.50mm ²	M1L-126A1	1.10	1.60	3.50	3.45	97BG-10C930-SBA
					JASO D 611(AVSS)	1.10	1.60	3.50	3.45	97BG-10C930-SBA
BU5T-14421-DA	34080-0102	34080-1102	GOLD	14	M1L-123A	1.65	2.45	3.95	3.65	XW4T-14603-MA
					M1L-135A1	1.65	2.45	3.80	3.65	XW4T-14603-FA
					M1L-123A	1.35	2.45	3.80	3.65	XW4T-14603-FA
BU5T-14421-EA	34080-0104	34080-1104	GOLD	18	M1L-123A	1.25	2.15	3.70	3.55	XW4T-14603-AA
					M1L-123A	1.15	2.15	3.60	3.55	XW4T-14603-AA
					M1L-123A	1.00	1.60	3.50	3.45	97BG-10C930-SBA
BU5T-14421-FA	34080-0106	34080-1106	GOLD	22	M1L-123A	1.00	1.60	3.50	3.45	97BG-10C930-SBA
BU5T-14421-DA	34080-0102	34080-1102	GOLD	2.00mm ²	JASO D 611(AVSS)	1.60	2.45	3.95	3.65	XW4T-14603-MA
BU5T-14421-DA	34080-0102	34080-1102	GOLD	1.50mm ²	M1L-126A1	1.40	2.45	3.80	3.65	XW4T-14603-FA
BU5T-14421-EA	34080-0104	34080-1104	GOLD	1.00mm ²	M1L-126A1	1.30	2.15	3.70	3.55	XW4T-14603-AA
				0.75mm ²	M1L-126A1	1.25	2.15	3.60	3.55	XW4T-14603-AA
BU5T-14421-FA	34080-0106	34080-1106	GOLD	0.50mm ²	M1L-126A1	1.10	1.60	3.50	3.45	97BG-10C930-SBA
					JASO D 611(AVSS)	1.10	1.60	3.50	3.45	97BG-10C930-SBA
BU5T-14421-AA	34080-0202	34080-1202	SILVER	14	M1L-123A	1.65	2.45	3.95	3.65	XW4T-14603-MA
					M1L-135A1	1.65	2.45	3.80	3.65	XW4T-14603-FA
					M1L-123A	1.35	2.45	3.80	3.65	XW4T-14603-FA
BU5T-14421-BA	34080-0204	34080-1204	SILVER	18	M1L-123A	1.25	2.15	3.70	3.55	XW4T-14603-AA
					M1L-123A	1.15	2.15	3.60	3.55	XW4T-14603-AA
					M1L-123A	1.00	1.60	3.50	3.45	97BG-10C930-SBA
BU5T-14421-CA	34080-0206	34080-1206	SILVER	22	M1L-123A	1.00	1.60	3.50	3.45	97BG-10C930-SBA
BU5T-14421-AA	34080-0202	34080-1202	SILVER	2.00mm ²	JASO D 611(AVSS)	1.60	2.45	3.95	3.65	XW4T-14603-MA
BU5T-14421-AA	34080-0202	34080-1202	SILVER	1.50mm ²	M1L-126A1	1.40	2.45	3.80	3.65	XW4T-14603-FA
BU5T-14421-BA	34080-0204	34080-1204	SILVER	1.00mm ²	M1L-126A1	1.30	2.15	3.70	3.55	XW4T-14603-AA
				0.75mm ²	M1L-126A1	1.25	2.15	3.60	3.55	XW4T-14603-AA
BU5T-14421-CA	34080-0206	34080-1206	SILVER	0.50mm ²	M1L-126A1	1.10	1.60	3.50	3.45	97BG-10C930-SBA
					JASO D 611(AVSS)	1.10	1.60	3.50	3.45	97BG-10C930-SBA

81

REFERENCE ---
 PART MUST COMPLY WITH MATERIAL SPECIFICATION MSB-1000000-41
 TO HELP PROTECT YOUR HEALTH, SAFETY AND THE ENVIRONMENT.
 DRAFTED IN ACCORDANCE WITH FAD 3RD ANGLE PROJ
 ENGINEERING DRAFTING STANDARD DIMENSIONS IN
 CURRENT AT INITIAL RELEASE MILLIMETERS
 CAD TYPE CAD LOC CAD FILE IS MASTER
 OPER. NO. UNIT DRAWING AU5T-14421-AA
 DESIGN DETAIL TITLE
 REVISIONS
 CHECKED SAFETY TERMINAL WIRE
 DRAWN SNAP ON MALE
 SCALE DATE DIVISION
 11 2009/07/09 PLANT

SIZE A4

CRIMP TOOL INFORMATION
SEE TABLE 2 FOR TABLED DIMENSIONS

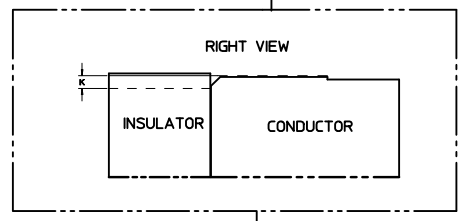
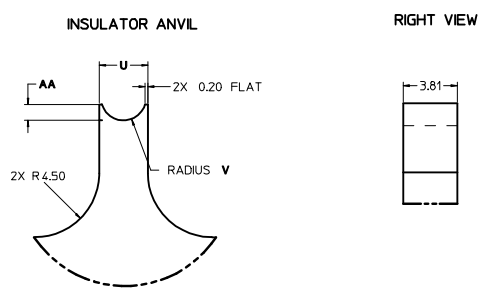
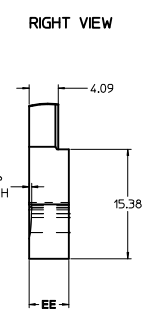
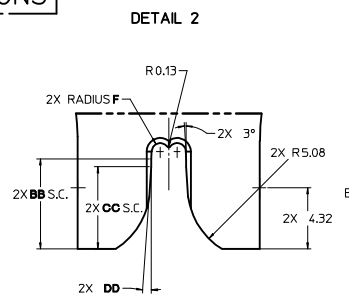
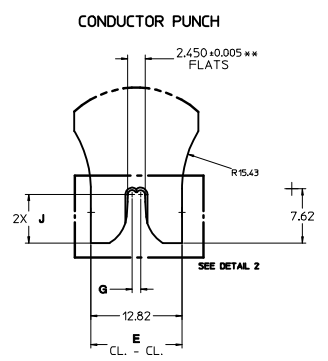
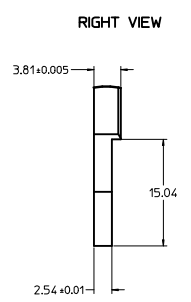
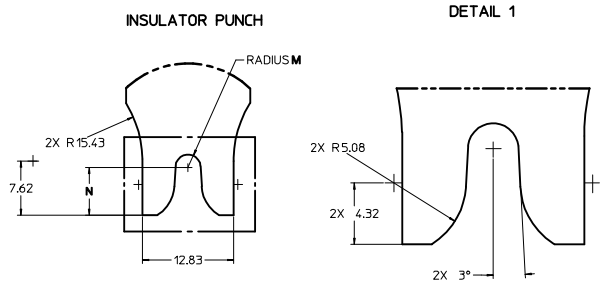

** 14-16 AWG. 1.5mm² & 2.0mm² ONLY

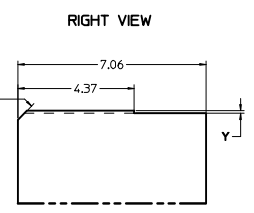
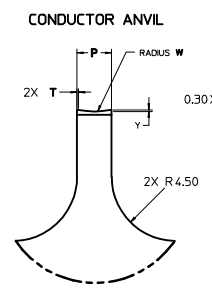

(B2)

TABLE 2 - TERMINAL GRIP/CRIMP TOOL DIMENSION REFERENCE TABLE

SUPPLIER PART NUMBER		FORD PART NO.	PLATING (STAMPING)	WIRE APPLICATION		A	B	C	D	D1	E	F	G	J	K	M	N	P	T	U	V	W	Y	AA	BB	CC	DD	EE
RIGHT PAYOFF	LEFT PAYOFF			SAE (AWG)	METRIC (mm ²)	+0.3	+0.20	+0.3	+0.15	+0.10	+0.01	+0.005	+0.005	+0.05	+0.01	+0.005	+0.10	+0.005	+0.03	+0.005	+0.05	+0.10	+0.01	+0.10	+0.01	+0.01	+0.01	+0.01
34080-0001	34080-1001	AU5T-14421-CA	TIN	14	2.0	3.6	5.00	1.7	2.90	0.90	12.82	0.600	1.194	6.86	0.90	1.778	6.73	2.438	0.12	3.429	1.575	6.11	0.10	1.13	6.34	5.79	4°	5.59
34080-0002	34080-1002	AU5T-14421-BA	TIN	16	1.5	3.6	5.00	1.7	2.90	0.90	12.82	0.600	1.194	6.86	0.90	1.778	6.73	2.438	0.12	3.429	1.575	6.11	0.10	1.13	6.34	5.79	4°	5.59
34080-0003	34080-1003	AU5T-14421-AA	TIN	20	0.75	3.3	5.00	1.3	2.90	0.70	12.57	0.556	0.963	7.34	0.70	1.753	6.73	2.085	0.33	3.378	1.699	1.94	0.14	0.88	-	-	-	3.81
34080-0102	34080-1102	BU5T-14421-DA	GOLD	22	0.5	2.5	4.85	0.9	2.90	0.55	11.92	0.414	0.714	6.27	0.55	1.737	7.06	1.576	0.26	3.327	1.524	2.00	0.07	1.08	-	-	-	3.81
34080-0104	34080-1104	BU5T-14421-EA	GOLD	14	2.0	3.6	5.00	1.7	2.90	0.90	12.82	0.600	1.194	6.86	0.90	1.778	6.73	2.438	0.12	3.429	1.575	6.11	0.10	1.13	6.34	5.79	4°	5.59
34080-0106	34080-1106	BU5T-14421-FA	GOLD	16	1.5	3.6	5.00	1.7	2.90	0.90	12.82	0.600	1.194	6.86	0.90	1.778	6.73	2.438	0.12	3.429	1.575	6.11	0.10	1.13	6.34	5.79	4°	5.59
34080-0202	34080-1202	BU5T-14421-AA	SILVER	18	1.0	3.3	5.00	1.3	2.90	0.70	12.57	0.556	0.963	7.34	0.70	1.753	6.73	2.085	0.33	3.378	1.699	1.94	0.14	0.88	-	-	-	3.81
34080-0204	34080-1204	BU5T-14421-BA	SILVER	20	0.75	3.3	5.00	1.3	2.90	0.70	12.57	0.556	0.963	7.34	0.70	1.753	6.73	2.085	0.33	3.378	1.699	1.94	0.14	0.88	-	-	-	3.81
34080-0206	34080-1206	BU5T-14421-CA	SILVER	22	0.5	2.5	4.85	0.9	2.90	0.55	11.92	0.414	0.714	6.27	0.55	1.737	7.06	1.576	0.26	3.327	1.524	2.00	0.07	1.08	-	-	-	3.81

LTRS		REVISIONS		
ORIGINATOR	CHECKER	ENGR APP	MATL APP	

REFERENCE =

PART MUST COMPLY WITH MATERIAL SPECIFICATION MSB-888P008-A1 TO HELP SAFEGUARD HEALTH, SAFETY AND THE ENVIRONMENT.

DRAFTED IN ACCORDANCE WITH FAD ENGINEERING DRAFTING STANDARD CURRENT AT INITIAL RELEASE

3RD ANGLE PROJ DIMENSIONS IN MILLIMETERS

OPER. NO.	UNIT	DRAWING	IS MASTER
		AU5T-14421-AA	
DESIGN REVISION	DETAIL	TITLE	BY
		TERMINAL WIRE SNAP ON MALE	3
			3
CHECKED INCHES	SAFETY	DATE	PLANT
		2006/07/09	
SCALE	DWG DIVISION	PLANT	
1:1			

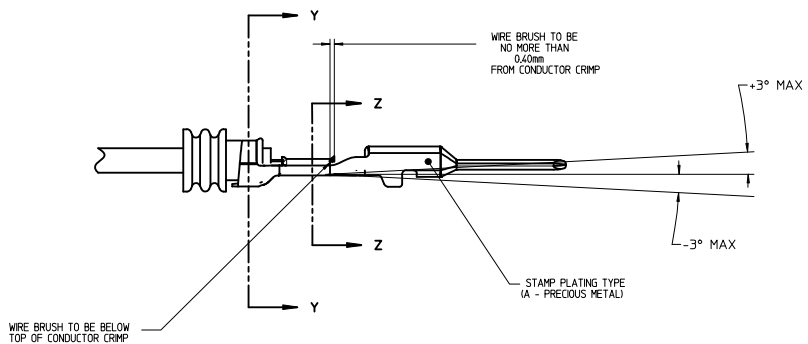

CRIMP INFORMATION
SEE TABLE 1 SHEET 2

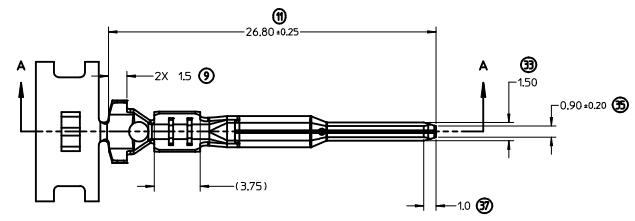
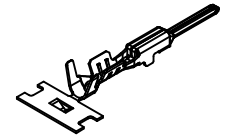
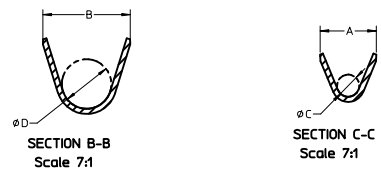

SEE TABLE 2 ON SHEET 3 FOR CHARTED DIM.

NOTES: (UNLESS OTHERWISE SPECIFIED)

- MATING TERMINAL SHOWN ON SD-34083-002
- MATERIAL: ASTM B422, UNS C19025, HR04
THICKNESS: 0.30 mm ± 0.01
TEMPER: FULL HARD (REF)
TENSILE: 496 MIN MPa
- MEETS PERFORMANCE SPECIFICATION FOR CABLE TO TERMINAL ELECTRICAL CRIMPS PER SAE/USCAR-21 (2/2004)
- MEETS PERFORMANCE STANDARD FOR AUTOMOTIVE ELECTRICAL CONNECTOR SYSTEMS FOR SAE/USCAR-2, REV. 4 (TEMP CLASS 3) (5/2004)
- MEETS ELECTRICAL CONNECTION SYSTEM DESIGN SPECIFICATION (SDSI) REV.14: (09/2007)
- MEETS FIELD CORRELATED LIFE TEST (FCLT) PER SAE/USCAR-20 (6/2004)
- REFERENCE FORD CAVITY SPECIFICATION 97BG-1421-ADA, REV. E
- INSERTION FORCE WITH CORRESPONDING FEMALE TERMINAL:
AVG. FORCE 3.1 N (REFERENCE)
2.7 N GOLD (REFERENCE)
2.9 N SILVER (REFERENCE)
- REFERENCE CRIMP SPECIFICATION (CS-34080-001) FOR ADDITIONAL INFORMATION.
- REFERENCE PK-31300-516 FOR REEL DIRECTION

PLATING NOTES:

- PRECIOUS METAL PLATED TERMINAL:
 - GOLD PLATING
 - UNDERPLATE: OVERALL ELECTRODEPOSITED DUCTILE SULFAMATE NICKEL THICKNESS 1.25 - 2.25 MICROMETERS
 - CONTACT ZONE A2: ELECTRODEPOSITED GOLD THICKNESS 0.76 MICROMETER MINIMUM
 - ZONE A1: REDUCED GOLD THICKNESS FROM ZONE A2 IS PERMITTED ZONE A1 SHALL BE COMPLETELY COVERED WITH NICKEL TO PREVENT EXPOSED BASE METAL
 - ZONE B: REDUCED GOLD THICKNESS FROM ZONE A2 AND REDUCED TIN THICKNESS FROM ZONE C IS PERMITTED ZONE B SHALL BE COMPLETELY COVERED WITH NICKEL TO PREVENT EXPOSED BASE METAL
 - ZONE C: TIN PLATING: ELECTRODEPOSITED TIN (100% TIN), MATTE FINISH THICKNESS 2.50 - 4.00 MICROMETERS
 - ZONE D: REDUCED TIN THICKNESS FROM ZONE C IS PERMITTED ZONE D SHALL BE COMPLETELY COVERED WITH NICKEL TO PREVENT EXPOSED BASE METAL

- SILVER PLATING
 - UNDERPLATE: OVERALL ELECTRODEPOSITED DUCTILE SULFAMATE NICKEL 1.25 - 2.25 MICROMETERS THICK
 - ZONE A2: ELECTRODEPOSITED PURE SILVER (0.5 PERCENT MAX IMPURITIES) SEMI-BRIGHT FINISH 1.9 - 3.3 MICROMETERS THICK OVER NICKEL
 - ANTI-TARNISH TREATMENT TO SILVER ZONES: EVABRITE S
 - ZONE A1: REDUCED SILVER PLATING THICKNESS FROM ZONE A2 IS PERMITTED OVER NICKEL
 - ZONE B: REDUCED SILVER PLATING THICKNESS FROM ZONE A2 AND REDUCED TIN PLATING THICKNESS FROM ZONE C IS PERMITTED OVER NICKEL
 - ZONE C: ELECTRODEPOSITED TIN (100% TIN) MATTE FINISH 2.5 - 4.00 MICROMETERS THICK OVER NICKEL
 - ZONE D: REDUCED TIN PLATING THICKNESS FROM ZONE C IS PERMITTED OVER NICKEL
- TIN PLATING
 - UNDERPLATE: ADVANCED BARRIER LAYER THICKNESS 0.25 - 1.00 MICROMETERS
 - TIN LAYER: ELECTRODEPOSITED REFLOW TIN (100% TIN) THICKNESS 0.50 - 1.00 MICROMETERS

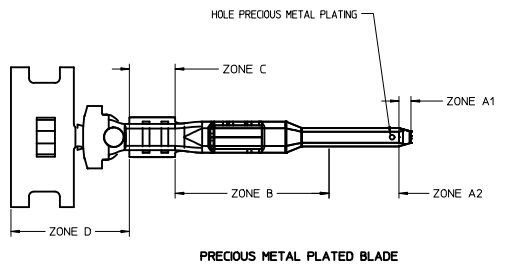

PRECIOUS METAL PLATED BLADE

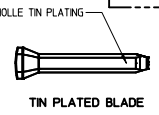

TIN PLATED BLADE

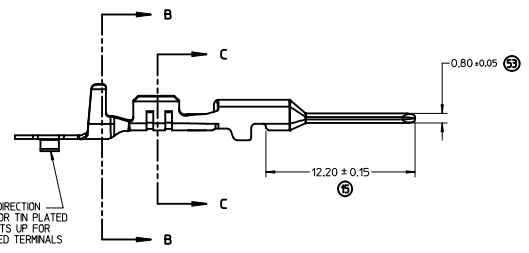

CARRIER BUMP DIRECTION POINTS DOWN FOR TIN PLATED TERMINALS POINTS UP FOR PRECIOUS PLATED TERMINALS

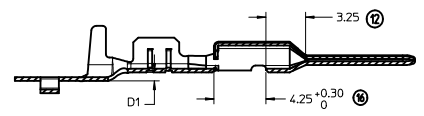

SECTION A-A

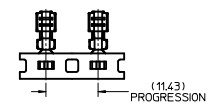
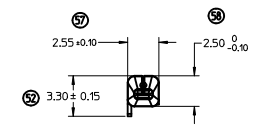

ENTER DESCRIPTION ELEC NO: UAU2010-0419 DRAWN BY: DRANKFERGUSON CHECKED BY: CHYKDA, DHR APPROVED BY: BMOSE DATE: 2009/12/02 DATE: 2009/12/02 DATE: 2009/12/02	QUALITY SYMBOLS =0 =0 ANGULAR ± 3°	GENERAL TOLERANCES (UNLESS SPECIFIED)		DIMENSION STYLE MM ONLY	SCALE 5:1	DESIGN UNITS METRIC	THIRD ANGLE PROJECTION
		4 PLACES ± mm ± INCH 3 PLACES ± --- ± --- 2 PLACES ± 0.10 ± --- 1 PLACE ± 0.3 ± ---	DRAWN BY: K. FERGUSON CHECKED BY: A. DHR APPROVED BY: B. MOSER DATE: 2008/06/09 DATE: 2008/06/09 DATE: 2008/09/06	DATE: 2008/06/09 DATE: 2008/06/09 DATE: 2008/09/06	TITLE: MX 150 BLADE CABLE SEAL	MATERIAL NO. SD-34080-001	DOCUMENT NO. SD-34080-001
DRAFT WHERE APPLICABLE MUST REMAIN WITHIN DIMENSIONS		SEE TABLE		THIS DRAWING CONTAINS INFORMATION THAT IS PROPRIETARY TO MOLEX INCORPORATED AND SHOULD NOT BE USED WITHOUT WRITTEN PERMISSION			

TABLE 1 – TERMINAL CRIMP DIMENSION REFERENCE TABLE

SUPPLIER PART NO.		PLATING	WIRE SIZE (AWG)	SPECIFICATION WIRE	CONDUCTOR CCH(SEC Z-Z) ±0.05	CONDUCTOR CCW(SEC Z-Z) ±0.10	INSULATOR ICH(SEC Y-Y) ±0.10	INSULATOR ICW(SEC Y-Y) ±0.10	QSR CABLE SEAL PART NO.	YAZAKI CABLE SEAL PART NO.
RIGHT PAYOFF	LEFT PAYOFF									
34080-0001	34080-1001	TIN	14	M1L-123A	1.65	2.45	3.95	3.65	-	7158-3033-40
				M1L-135A1	1.65	2.45	3.80	3.65	E-1644-02	-
34080-0002	34080-1002	TIN	16	M1L-123A	1.35	2.45	3.80	3.65	E-1644-02	-
				M1L-123A	1.25	2.15	3.70	3.55	E-1644-00	-
				SAE J1128 (GXL)	1.25	2.15	3.90	3.55	E-1644-02	-
				M1L-123A	1.15	2.15	3.60	3.55	E-1644-00	-
34080-0003	34080-1003	TIN	20	SAE J1128 (GXL)	1.15	2.15	3.80	3.55	E-1644-02	-
				M1L-123A	1.00	1.60	3.50	3.45	E-1644-01	-
34080-0001	34080-1001	TIN	2.00mm ²	JASO D 611(AVSS)	1.60	2.45	3.95	3.65	-	7158-3033-40
34080-0001	34080-1001	TIN	1.50mm ²	M1L-126A1	1.40	2.45	3.80	3.65	E-1644-02	-
34080-0002	34080-1002	TIN	1.00mm ²	M1L-126A1	1.30	2.15	3.70	3.55	E-1644-00	-
				0.75mm ²	M1L-126A1	1.25	2.15	3.60	3.55	E-1644-00
34080-0003	34080-1003	TIN	0.50mm ²	M1L-126A1	1.10	1.60	3.50	3.45	E-1644-01	-
				JASO D 611(AVSS)	1.10	1.60	3.50	3.45	E-1644-01	-
34080-0102	34080-1102	GOLD	14	M1L-123A	1.65	2.45	3.95	3.65	-	7158-3033-40
				M1L-135A1	1.65	2.45	3.80	3.65	E-1644-02	-
34080-0104	34080-1104	GOLD	16	M1L-123A	1.35	2.45	3.80	3.65	E-1644-02	-
				M1L-123A	1.25	2.15	3.70	3.55	E-1644-00	-
				SAE J1128 (GXL)	1.25	2.15	3.90	3.55	E-1644-02	-
				M1L-123A	1.15	2.15	3.60	3.55	E-1644-00	-
34080-0106	34080-1106	GOLD	22	SAE J1128 (GXL)	1.15	2.15	3.80	3.55	E-1644-02	-
				M1L-123A	1.00	1.60	3.50	3.45	E-1644-01	-
34080-0102	34080-1102	GOLD	2.00mm ²	JASO D 611(AVSS)	1.60	2.45	3.95	3.65	-	7158-3033-40
34080-0102	34080-1102	GOLD	1.50mm ²	M1L-126A1	1.40	2.45	3.80	3.65	E-1644-02	-
34080-0104	34080-1104	GOLD	1.00mm ²	M1L-126A1	1.30	2.15	3.70	3.55	E-1644-00	-
				0.75mm ²	M1L-126A1	1.25	2.15	3.60	3.55	E-1644-00
34080-0106	34080-1106	GOLD	0.50mm ²	M1L-126A1	1.10	1.60	3.50	3.45	E-1644-01	-
				JASO D 611(AVSS)	1.10	1.60	3.50	3.45	E-1644-01	-
34080-0202	34080-1202	SILVER	14	M1L-123A	1.65	2.45	3.95	3.65	-	7158-3033-40
				M1L-135A1	1.65	2.45	3.80	3.65	E-1644-02	-
34080-0204	34080-1204	SILVER	16	M1L-123A	1.35	2.45	3.80	3.65	E-1644-02	-
				M1L-123A	1.25	2.15	3.70	3.55	E-1644-00	-
				SAE J1128 (GXL)	1.25	2.15	3.90	3.55	E-1644-02	-
				M1L-123A	1.15	2.15	3.60	3.55	E-1644-00	-
34080-0206	34080-1206	SILVER	20	SAE J1128 (GXL)	1.15	2.15	3.80	3.55	E-1644-02	-
				M1L-123A	1.00	1.60	3.50	3.45	E-1644-01	-
34080-0202	34080-1202	SILVER	2.00mm ²	JASO D 611(AVSS)	1.60	2.45	3.95	3.65	-	7158-3033-40
34080-0202	34080-1202	SILVER	1.50mm ²	M1L-126A1	1.40	2.45	3.80	3.65	E-1644-02	-
34080-0204	34080-1204	SILVER	1.00mm ²	M1L-126A1	1.30	2.15	3.70	3.55	E-1644-00	-
				0.75mm ²	M1L-126A1	1.25	2.15	3.60	3.55	E-1644-00
34080-0206	34080-1206	SILVER	0.50mm ²	M1L-126A1	1.10	1.60	3.50	3.45	E-1644-01	-
				JASO D 611(AVSS)	1.10	1.60	3.50	3.45	E-1644-01	-

ENTER DESCRIPTION EC NO. UAC200-0475 DRAWN BY K. FERGUSON CHECKED BY A. DHIR APPROVED BY B. MOSER DATE 2008/06/09 DATE 2008/06/09 DATE 2008/09/06 REV.	QUALITY SYMBOLS ▽=0 ▽=0	GENERAL TOLERANCES (UNLESS SPECIFIED) mm INCH 4 PLACES ± .005 ± .002 3 PLACES ± .005 ± .002 2 PLACES ± .010 ± .004 1 PLACE ± 0.3 ± .012 ANGULAR ± 3°	DIMENSION STYLE MM ONLY DRAWN BY DATE K. FERGUSON 2008/06/09 CHECKED BY DATE A. DHIR 2008/06/09 APPROVED BY DATE B. MOSER 2008/09/06	SCALE 1:1 DESIGN UNITS METRIC THIRD ANGLE PROJECTION	TITLE MX 150 BLADE CABLE SEAL
	DRAFT WHERE APPLICABLE MUST REMAIN WITHIN DIMENSIONS		MATERIAL NO. SEE TABLE DOCUMENT NO. SD-34080-001 SHEET NO. 2 OF 3		
	THIS DRAWING CONTAINS INFORMATION THAT IS PROPRIETARY TO MOLEX INCORPORATED AND SHOULD NOT BE USED WITHOUT WRITTEN PERMISSION				
	MOLEX MOLEX INCORPORATED				

CRIMP TOOL INFORMATION

SEE TABLE 2 FOR TABLED DIMENSIONS

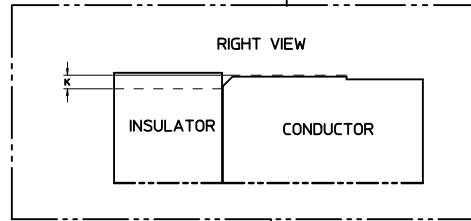
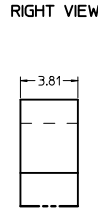
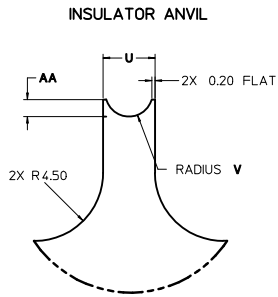
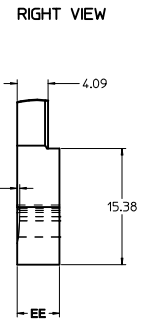
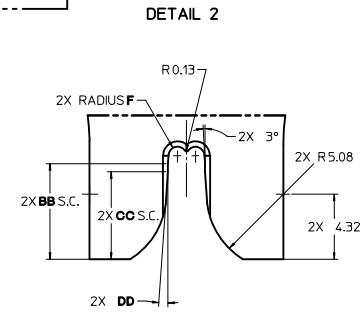
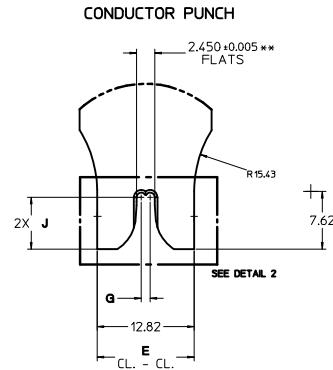
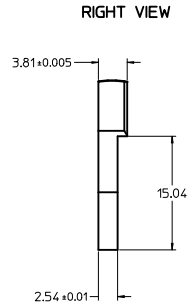
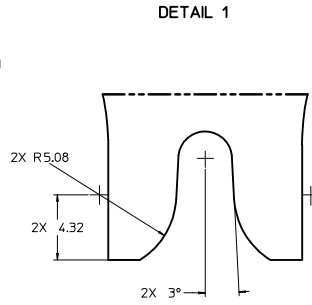
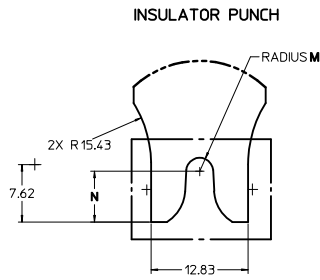

** 14-16 AWG, 1.5mm² & 2.0mm² ONLY

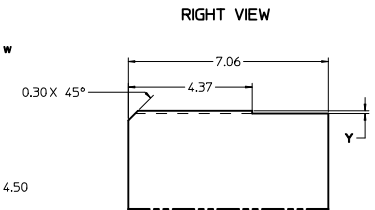
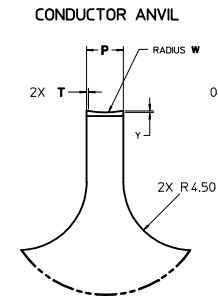

TABLE 2 - TERMINAL GRIP/CRIMP TOOL DIMENSION REFERENCE TABLE

SUPPLIER PART NUMBER		PLATING (STAMPING)	WIRE APPLICATION		A	B	C	D	D1	E	F	G	J	K	M	N	P	T	U	V	W	Y	AA	BB	CC	DD	EE
RIGHT PAYOFF	LEFT PAYOFF		SAE (AWG)	METRIC (mm ²)	±0.3	±0.20	±0.3	±0.15	±0.10	±0.01	±0.005	±0.005	±0.05	±0.01	±0.005	±0.10	±0.005	±0.03	±0.005	±0.005	±0.10	±0.01	±0.10	±0.01	±0.01	±0.01	±0.10
34080-0001	34080-1001	TIN	14	2.0	3.6	5.00	1.7	2.90	0.90	12.82	0.600	1.194	6.86	0.90	1.778	6.73	2.438	0.12	3.429	1.575	6.11	0.10	1.13	6.34	5.79	4°	5.59
			16	1.5	3.6	5.00	1.7	2.90	0.90	12.82	0.600	1.194	6.86	0.90	1.778	6.73	2.438	0.12	3.429	1.575	6.11	0.10	1.13	6.34	5.79	4°	5.59
34080-0002	34080-1002	TIN	18	1.0	3.3	5.00	1.3	2.90	0.70	12.57	0.556	0.963	7.34	0.70	1.753	6.73	2.085	0.33	3.378	1.699	1.94	0.14	0.88	-	-	-	3.81
			20	0.75	3.3	5.00	1.3	2.90	0.70	12.57	0.556	0.963	7.34	0.70	1.753	6.73	2.085	0.33	3.378	1.699	1.94	0.14	0.88	-	-	-	3.81
34080-0003	34080-1003	TIN	22	0.5	2.5	4.85	0.9	2.90	0.55	11.92	0.414	0.714	6.27	0.55	1.737	7.06	1.576	0.26	3.327	1.524	2.00	0.07	1.08	-	-	-	3.81
34080-0102	34080-1102	GOLD	14	2.0	3.6	5.00	1.7	2.90	0.90	12.82	0.600	1.194	6.86	0.90	1.778	6.73	2.438	0.12	3.429	1.575	6.11	0.10	1.13	6.34	5.79	4°	5.59
			16	1.5	3.6	5.00	1.7	2.90	0.90	12.82	0.600	1.194	6.86	0.90	1.778	6.73	2.438	0.12	3.429	1.575	6.11	0.10	1.13	6.34	5.79	4°	5.59
34080-0104	34080-1104	GOLD	18	1.0	3.3	5.00	1.3	2.90	0.70	12.57	0.556	0.963	7.34	0.70	1.753	6.73	2.085	0.33	3.378	1.699	1.94	0.14	0.88	-	-	-	3.81
			20	0.75	3.3	5.00	1.3	2.90	0.70	12.57	0.556	0.963	7.34	0.70	1.753	6.73	2.085	0.33	3.378	1.699	1.94	0.14	0.88	-	-	-	3.81
34080-0106	34080-1106	GOLD	22	0.5	2.5	4.85	0.9	2.90	0.55	11.92	0.414	0.714	6.27	0.55	1.737	7.06	1.576	0.26	3.327	1.524	2.00	0.07	1.08	-	-	-	3.81
			14	2.0	3.6	5.00	1.7	2.90	0.90	12.82	0.600	1.194	6.86	0.90	1.778	6.73	2.438	0.12	3.429	1.575	6.11	0.10	1.13	6.34	5.79	4°	5.59
34080-0202	34080-1202	SILVER	16	1.5	3.6	5.00	1.7	2.90	0.90	12.82	0.600	1.194	6.86	0.90	1.778	6.73	2.438	0.12	3.429	1.575	6.11	0.10	1.13	6.34	5.79	4°	5.59
			18	1.0	3.3	5.00	1.3	2.90	0.70	12.57	0.556	0.963	7.34	0.70	1.753	6.73	2.085	0.33	3.378	1.699	1.94	0.14	0.88	-	-	-	3.81
34080-0204	34080-1204	SILVER	20	0.75	3.3	5.00	1.3	2.90	0.70	12.57	0.556	0.963	7.34	0.70	1.753	6.73	2.085	0.33	3.378	1.699	1.94	0.14	0.88	-	-	-	3.81
			22	0.5	2.5	4.85	0.9	2.90	0.55	11.92	0.414	0.714	6.27	0.55	1.737	7.06	1.576	0.26	3.327	1.524	2.00	0.07	1.08	-	-	-	3.81

ENTER DESCRIPTION EC NO. UAU2010-0419 DRAWN BY K. FERGUSON 2008/12/02 CHECKED BY A. DHIR APPROVED BY B. MOSER REV B2	QUALITY SYMBOLS ▽=0 ▽=0	GENERAL TOLERANCES (UNLESS SPECIFIED) mm INCH 4 PLACES ± --- ± --- 3 PLACES ± --- ± --- 2 PLACES ± 0.10 ± --- 1 PLACE ± 0.3 ± --- ANGULAR ± 3°	DIMENSION STYLE MM ONLY DRAWN BY DATE K. FERGUSON 2008/06/09 CHECKED BY DATE A. DHIR 2008/06/09 APPROVED BY DATE B. MOSER 2008/09/06	SCALE 1:1 DESIGN UNITS METRIC THIRD ANGLE PROJECTION	TITLE MX 150 BLADE CABLE SEAL	MATERIAL NO. SEE TABLE DOCUMENT NO. SD-34080-001	SHEET NO. 3 OF 3
	DRAFT WHERE APPLICABLE MUST REMAIN WITHIN DIMENSIONS						
	THIS DRAWING CONTAINS INFORMATION THAT IS PROPRIETARY TO MOLEX INCORPORATED AND SHOULD NOT BE USED WITHOUT WRITTEN PERMISSION						
	MOLEX MOLEX INCORPORATED						