



# SMTPA Series

Telecommunication Protection

**BREAKDOWN VOLTAGE: 62 --- 270 V**

**PEAK PULSE POWER: 5000 W**

## Features

- ◇ Bidirectional crowbar protection
- ◇ Voltage range from 62V to 270V
- ◇ Low capacitance from 15pF to 30pF typ.@50V
- ◇ Low leakage current:  $I_R=2\mu A$  max
- ◇ Holding current:  $I_H=150mA$  min
- ◇ Repetitive peak pulse current:  
 $I_{PP}=50A, 10/1000\mu s$ .

## DESCRIPTION

The SMTPAxxx series has been designed to protect telecommunication equipment against lightning and transient induced by AC power lines. The package/die size ratio has been optimized by using the SMB package.

## SMB

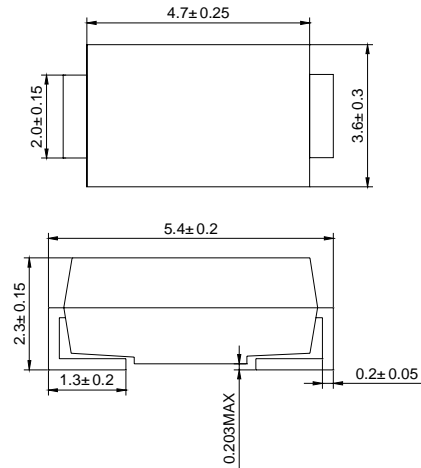

Dimensions in millimeters

## SCHEMATIC DIAGRAM

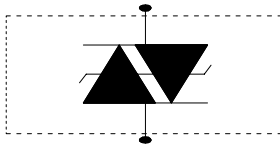

Complies with the following standards:	Peak surge voltage (V)	Voltage waveform ( $\mu s$ )	Current waveform ( $\mu s$ )	Required peak current (A)	Necessary resistor ( $\Omega$ )
GR-1089 Core first level	2500	2/10	2/10	500	12
	1000	10/1000	10/1000	100	10
GR-1089 Core second level	5000	2/10	2/10	500	24
GR-1089 Core Intra-building	1500	2/10	2/10	100	0
ITU-T-K20/K21	6000	10/700	5/310	150	53
	1500			37.5	0
ITU-T-K20 (IEC61000-4-2)	6000	1/60 ns	ESD contact discharge ESD air discharge	0	0
	8000			0	0
VDE0433	4000	0	5/310	100	21.5
	2000			50	0
VDE0878	4000	1.2/50	1/20	100	0
	2000			50	0
IEC-1000-4-5	4000	10/700	5/310	100	21.5
	4000	1.2/50	8/20	100	0
FCCPart68, lightning surgetypeA	1500	10/160	10/160	200	12.5
	800	10/560	10/560	100	6.5
FCCPart68, lightning surgetypeB	1000	9/720	5/320	25	0

## ABSOLUTE MAXIMUM RATINGS (T<sub>A</sub>=25°C)

Symbol	Parameter	Value	Unit
I <sub>pp</sub>	Repetitive peak pulse current	10/1000 μs	50
		8/20μs	100
		10/560μs	55
		5/310μs	65
		10/160μs	75
		1/20μs	100
		2/10μs	150
I <sub>FS</sub>	Fail safe mode: maximum current	8/20μs	2.5
I <sub>FSM</sub>	Non repetitive surge peak on-state current (Sinusoidal)	t=20ms	30
		t=16.6ms	32
		t=0.2s	17
		t=2s	9
I <sup>2</sup> t	I <sup>2</sup> t value for fusing	t=16.6ms t=20ms	8.5 9
T <sub>stg</sub>	Storage temperature range	Maximum	-55to+150
T <sub>j</sub>	junction temperature		150
T <sub>L</sub>	Storage temperature range Maximum junction temperature		260

## THERMAL RESISTANCES

Symbol	Parameter	Value	Unit
R <sub>th(j-l)</sub>	Junction to leads	20	°C/W
R <sub>th(j-a)</sub>	Junction to ambient with recommended footprint	100	°C/W

Type	Device Marking Code	I <sub>RM</sub> @ V <sub>RM</sub>		I <sub>R</sub> @ V <sub>R</sub>		DYNAMIC V <sub>BO</sub> @ I <sub>BO</sub>		STATIC V <sub>BO</sub> @ I <sub>BO</sub>		I <sub>H</sub>	C	C
		max. μA	V	max. mA	V	max. V	max. mA	max. V	max. mA	min. mA	typ. pF	typ. pF
SMTPA62	T62	2	56	1.0	62	85	800	800	82	150	30	50
SMTPA68	T68		61		68	93			90	150	30	45
SMTPA100	T100		90		100	135			133	150	20	40
SMTPA120	T120		108		120	160			160	150	20	40
SMTPA130	T130		117		130	173			173	150	20	35
SMTPA180	T180		162		180	235			240	150	15	30
SMTPA200	T200		180		200	262			267	150	15	30
SMTPA220	T220		198		220	285			293	150	15	30
SMTPA240	T240		216		240	300			320	150	15	30
SMTPA270	T270		243		270	350			360	150	15	30

## ELECTRICAL CHARACTERISTICS (T<sub>A</sub>=25°C)

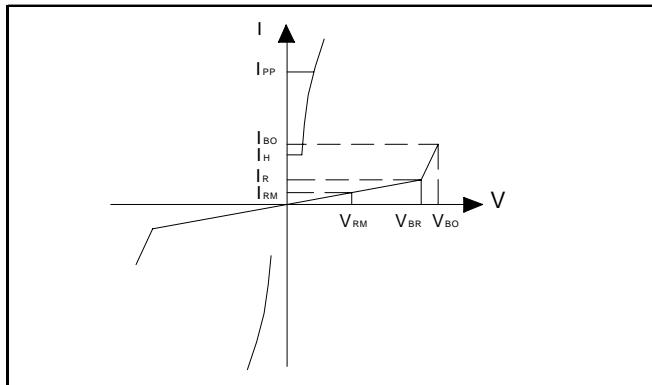

Symbol	Parameter
V <sub>RM</sub>	Stand-off voltage
I <sub>RM</sub>	Leakage current at stand-off voltage
V <sub>R</sub>	Continuous reverse voltage
V <sub>BR</sub>	Breakdown voltage
V <sub>BO</sub>	Break over voltage
I <sub>H</sub>	Holding current
I <sub>BO</sub>	Break over current
I <sub>PP</sub>	Peak pulse current
C	Capacitance

Note2: See test circuit2.

Note4: V<sub>R</sub>=50V bias, V<sub>RMS</sub>=1V, F=1MHz.

Note1: See functional break over voltage test circuit 1.

Note3: See functional holding current test circuit 3.

Note5: V<sub>R</sub>=2V bias, V<sub>RMS</sub>=1V, F=1MHz.

## Ratings AND Characteristic Curves

### TEST CIRCUIT 1 FOR DYNAMIC $I_{BO}$ AND $V_{BO}$ PARAMETERS:

100V/ $\mu$ s,  $di/dt < 10A/\mu$ s,  $I_{pp} = 50A$

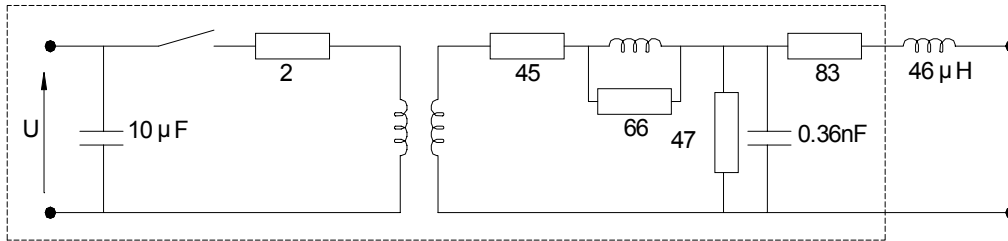

KEY TEK 'SYSTEM 2' GENERATOR WITH PN2461 MODULE

1kV/ $\mu$ s,  $di/dt < 10A/\mu$ s,  $I_{pp} = 10A$

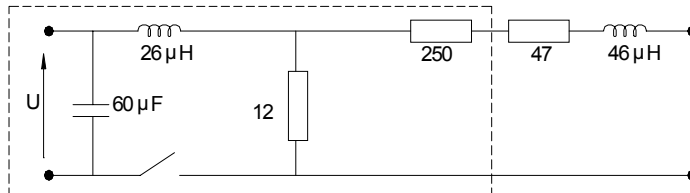

KEY TEK 'SYSTEM 2' GENERATOR WITH PN2461 MODULE

### TEST CIRCUIT 2 FOR $I_{BO}$ AND $V_{BO}$ PARAMETERS:

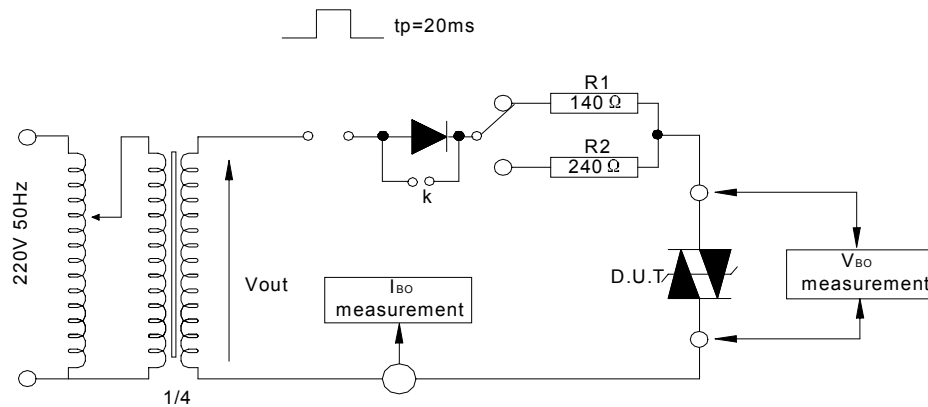

#### TEST PROCEDURE :

Pulse Test duration ( $t_p = 20ms$ ):

- For Bidirectional devices = Switch K is closed
- For Unidirectional devices = Switch K is open.

$V_{OUT}$  Selection

- Device with  $V_{BO} < 200$  Volt
  - $V_{OUT} = 250 V_{RMS}$ ,  $R1 = 140 \Omega$ .
- Device with  $V_{BO} \geq 200$  Volt
  - $V_{OUT} = 480 V_{RMS}$ ,  $R2 = 240 \Omega$ .

## Ratings AND Characteristic Curves

### TEST CIRCUIT 3 FOR $I_H$ PARAMETERS:

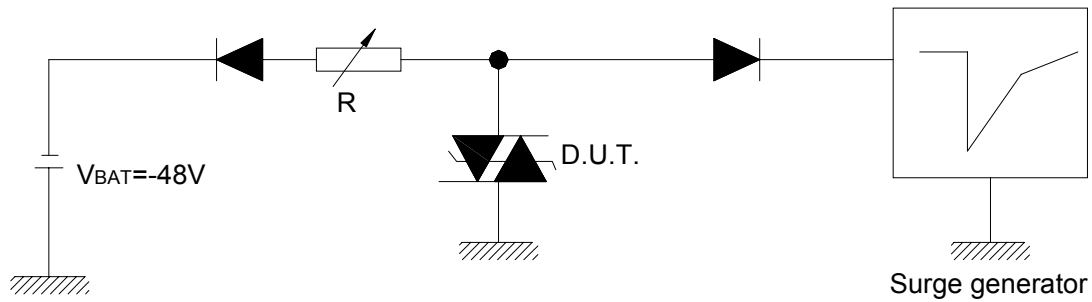

This is a GO-NO GO Test which allows to confirm the holding current ( $I_H$ ) level in a functional test circuit.

#### TESTPROCEDURE :

- 1) Adjust the current level at the  $I_H$  value by short circuiting the AK of the D.U.T.
- 2) Fire the D.U.T with a surge current :  $I_{pp} = 10A$  , 10/1000 ms.
- 3) The D.U.T will come back off-state within 50ms max.

#### PACKAGE MECHANICAL DATA

SMB(JEDEC DO-214AA)

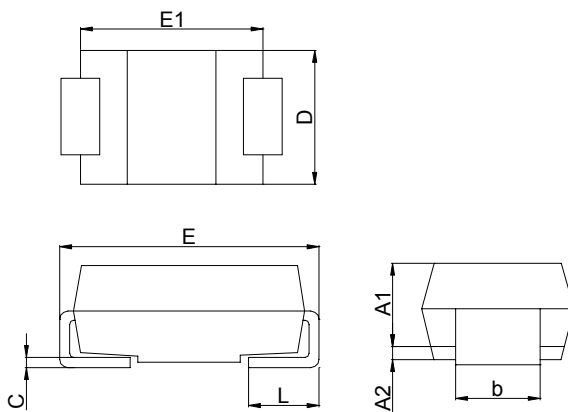

REF.	DIMENSIONS			
	MILLIMETERS		INCHES	
	MIN.	MAX.	MIN.	MAX.
A1	1.9	2.45	0.075	0.096
A2	0.05	0.2	0.002	0.008
b	1.95	2.2	0.077	0.087
c	0.15	0.41	0.006	0.016
E	5.1	5.6	0.201	0.22
E1	4.05	4.6	0.159	0.181
D	3.3	3.95	0.13	0.156
L	0.75	1.6	0.03	0.063

#### FOOT PRINT in millimeters (inches)

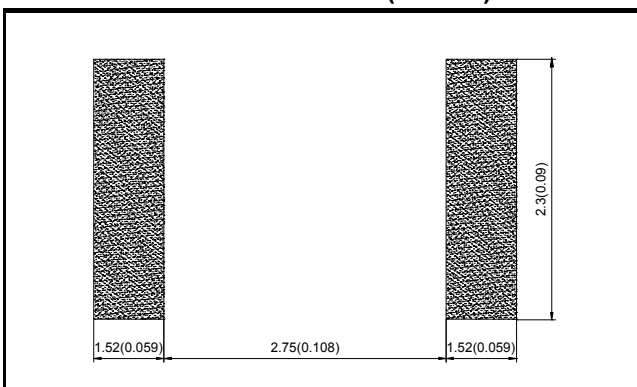

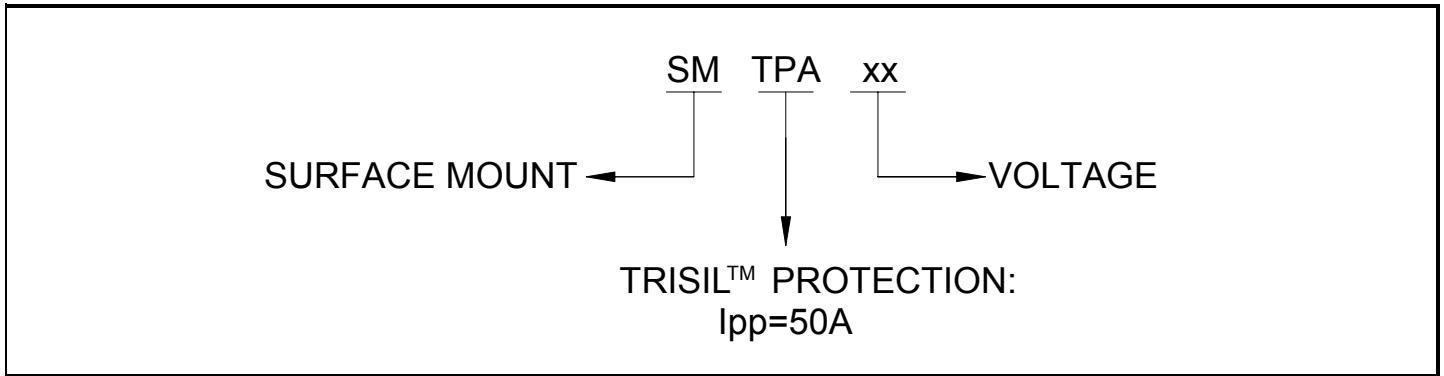
**ORDER CODE**

**ORDERING INFORMATION**

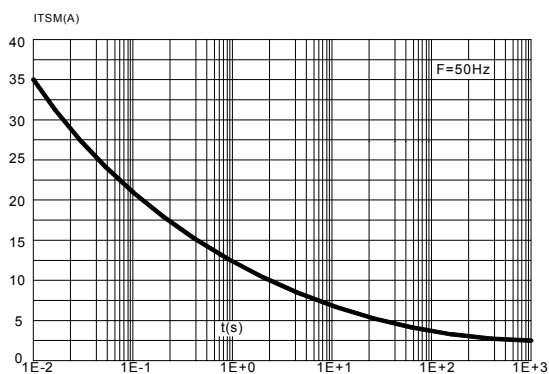
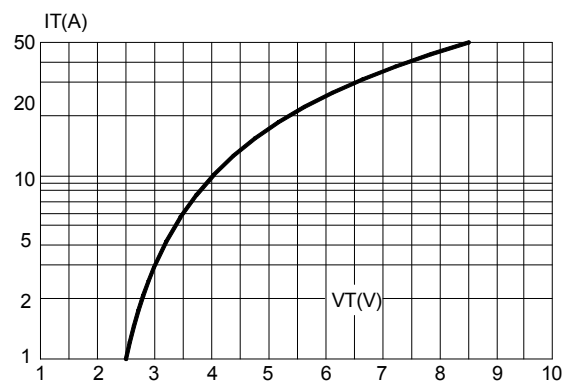
part number	marking	package	weight	base QTY	delivery mode
SMTPA62	U01	SMB	0.11g	5000	tape & reel
SMTPA68	U05				
SMTPA100	U13				
SMTPA120	U17				
SMTPA130	U19				
SMTPA180	U25				
SMTPA200	U27				
SMTPA220	U31				
SMTPA240	U35				
SMTPA270	U39				

**FIG.1 -- NON REPETITIVE SURGE PEAK ON-STATE CURRENT VERSUS OVERLOAD DURATION**

**FIG.2 -- ON-STATE VOLTAGE VERSUS ON-STATE CURRENT (TYPICAL VALUES).**

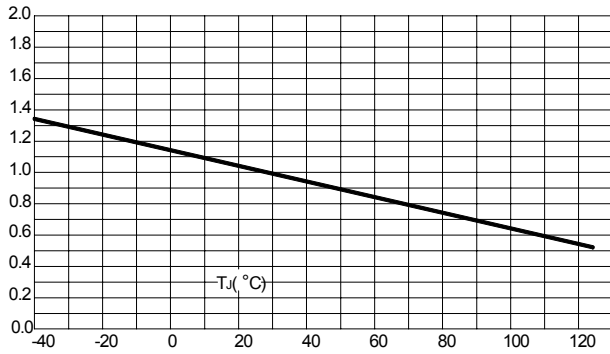
## Ratings AND Characteristic Curves

**FIG.3 -- RELATIVE VARIATION OF HOLDING CURRENT VERSUS JUNCTION TEMPERATURE**

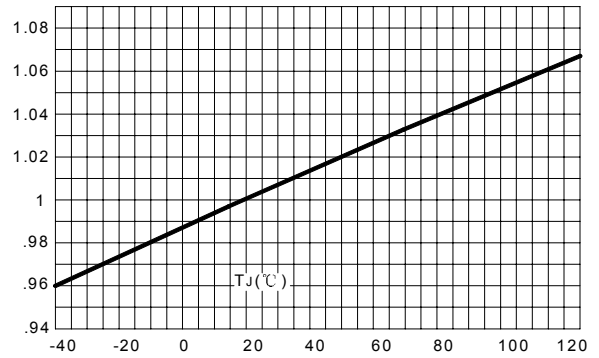

**FIG.4 -- RELATIVE VARIATION OF BREAKOVER VOLTAGE VERSUS JUNCTION TEMPERATURE**



**FIG.5 -- RELATIVE VARIATION OF LEAKAGE CURRENT VERSUS JUNCTION TEMPERATURE (TYPICAL VALUES).**

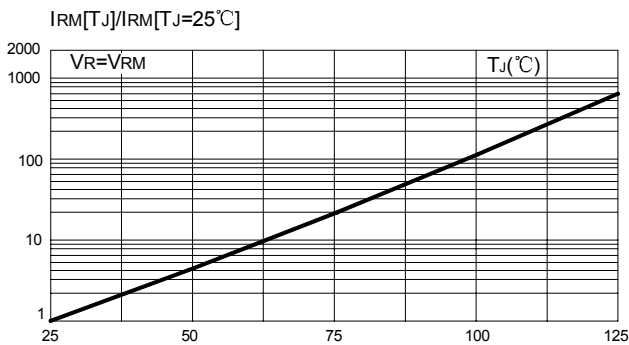

**FIG.6 -- RELATIVE VARIATION OF THERMAL IMPEDANCE VERSUS PULSE DURATION**

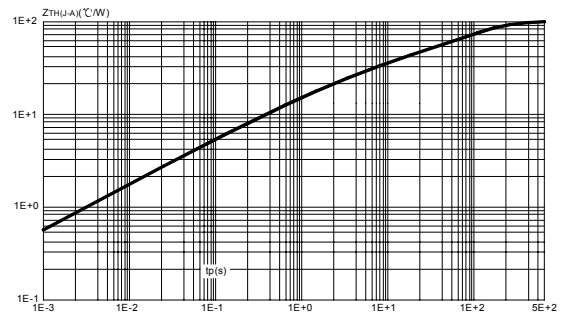

**FIG.7 -- RELATIVE VARIATION OF JUNCTION CAPACITANCE VERSUS REVERSE VOLTAGE APPLIED (TYPICAL VALUES)**

