

Radial Taping Dimensions of Ceramic Resonator and Filter

▶ Radial Taping Dimensions of Ceramic Resonators and Ceramic Filters

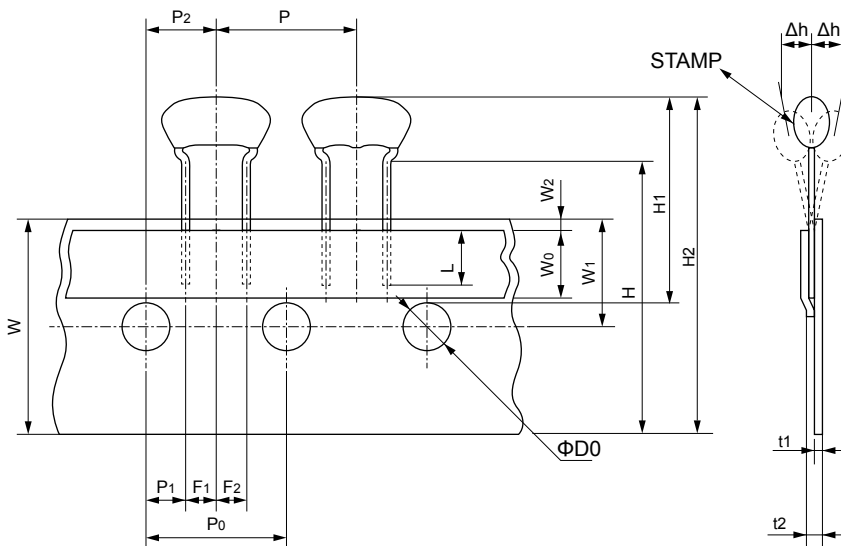

Radial Taping Dimensions of Ceramic Resonators and Ceramic Filters

Notes:

- * Include the slant of products.
- ** Varies with part number.

Mark	Size (Unit: mm)
P	12.7±0.5
P0	12.7±0.2
P1	3.85±0.5
P2	6.35±1.3 *
F	0.5 ^{+0.5} _{-0.3}
dxt	0.5x0.3(±0.1)
W	18.0±0.5
W0	5.5±0.5
W1	9.0±0.5
W2	1.0max
H	18.0 ^{+0.5} _{-1.0}
H1	27.0max **
H2	36.0max **
L	3.0main
ΦD0	4.0±0.2
t1	0.6±0.2
t2	1.5max
Δh	1.0max

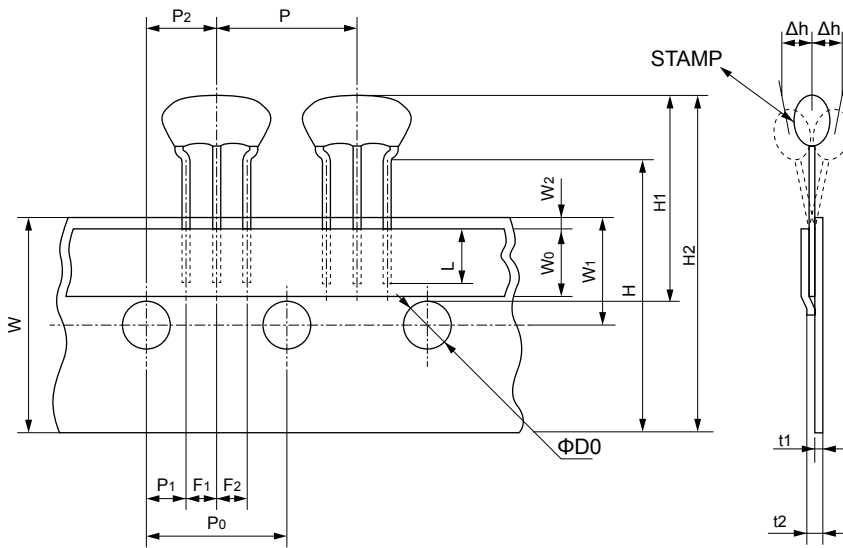

Radial Taping Dimensions of Ceramic Resonators and Ceramic Filters

Notes:

- * Include the slant of products.
- ** Varies with part number.

Mark	Size (Unit: mm)
P	12.7±0.5
P0	12.7±0.2
P1	3.85±0.5
P2	6.35±1.3 *
F	0.5 ^{+0.5} _{-0.3}
dxt	0.5x0.3(±0.1)
W	18.0±0.5
W0	5.5±0.5
W1	9.0±0.5
W2	1.0max
H	18.0 ^{+0.5} _{-1.0}
H1	27.0max **
H2	36.0max **
L	3.0main
ΦD0	4.0±0.2
t1	0.6±0.2
t2	1.5max
Δh	1.0max

Packing Method

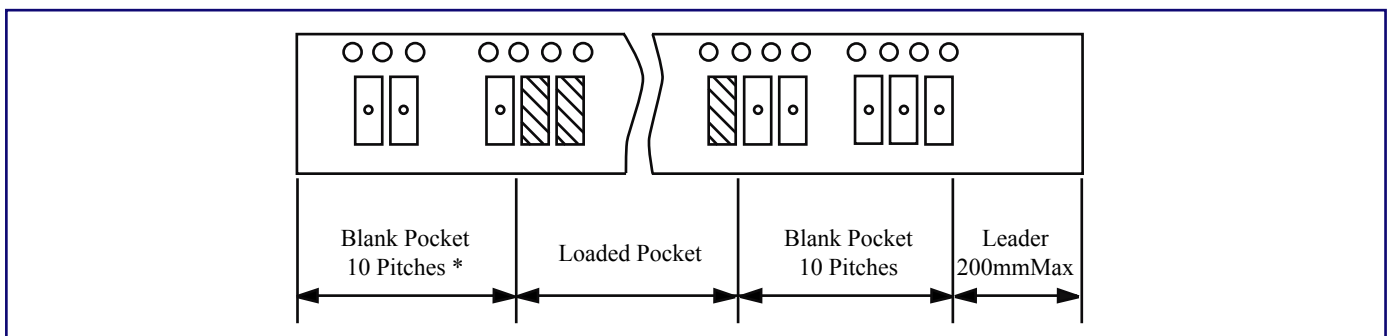

▶ Reel Dimensions (Unit: mm)

ΦA	ΦB	W	T	Pieces per reel	Carrier tape size
179 ± 2	60 typ	8.4 min	14.0max	3000typ	8
179 ± 2	60typ	12.4min	19.4max	3000typ	12
179 ± 2	60 typ	12.4 min	19.4max	1000typ	12
179 ± 2	60typ	16.4min	22.4max	1000typ	16
330 ± 3	80min	12.4min	19.4max	4000typ	12
330 ± 3	80min	16.4min	22.4max	4000typ	16

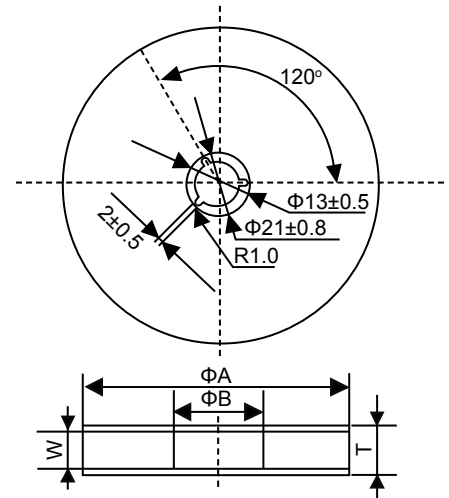

▶ Tape Dimensions (Unit: mm)

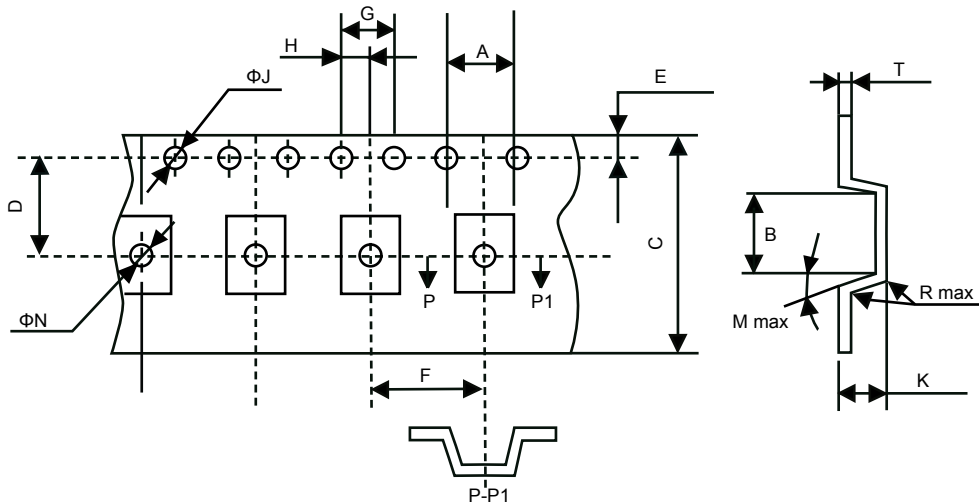

Code Tolerance Part Number	A	B	C	D	E	F	G	H	ΦJ	ΦN	M max	R max	K	T
	± 0.2	± 0.2	± 0.3	± 0.1	± 0.1	± 0.1	± 0.1	± 0.1	± 0.1	± 0.1	max	max	± 0.2	± 0.1
ZTACC MG ZTTCC MG	3.8	7.8	16.0	7.5	1.75	8.0	4.0	2.0	1.5	1.6	10°	0.3	2.1	0.3
ZTACR MG ZTTCR MG	2.2	4.7	12.0	5.5	1.75	4.0	4.0	2.0	1.6	1.6	3°	0.3	1.3	0.3
ZTACS MT/MX ZTTCS MT/MX	5.0	4.4	12.0	5.5	1.75	8.0	4.0	2.0	1.5	1.6	10°	0.3	1.8	0.3
ZTACV MT/MX ZTTCV MT/MX	3.4	4.0	12.0	5.5	1.75	8.0	4.0	2.0	1.5	1.6	10°	0.3	1.3	0.3
ZTACW MX ZTTCW MX	2.2	2.8	8.0	3.5	1.75	4.0	4.0	2.0	1.6	1.1	3°	0.3	1.3	0.2

▶ Test Condition of Peeling Strength

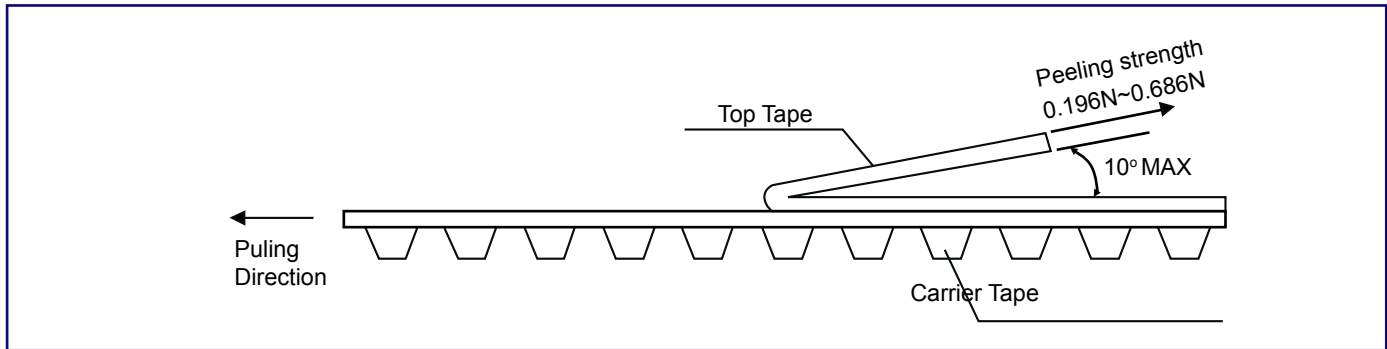

▶ Recommended Reflow Soldering Standard Conditions

