

N-CHANNEL SILICON POWER MOS-FET

Features

- High speed switching
- Low on-resistance
- No secondary breakdown
- Low driving power
- High voltage
- $V_{GSS} = \pm 30V$  Guarantee
- Avalanche-proof

Applications

- Switching regulators
- UPS
- DC-DC converters
- General purpose power amplifier

Outline Drawings

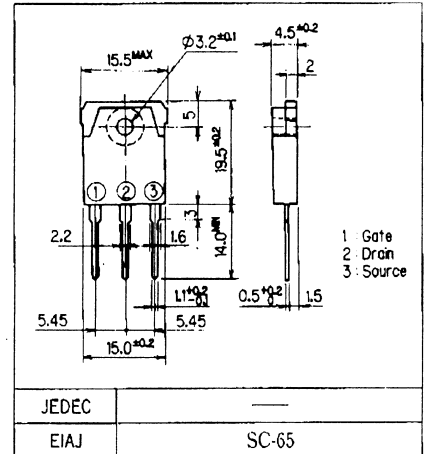

Max. Ratings and Characteristics

Absolute Maximum Ratings ( $T_c = 25^\circ C$ )

Items	Symbols	Ratings	Units
Drain-source voltage	$V_{DSS}$	800	V
Continuous drain current	$I_D$	7	A
Pulsed drain current	$I_{D(puls)}$	21	A
Continuous reverse drain current	$I_{DR}$	7	A
Gate-source peak voltage	$V_{GSS}$	$\pm 30$	V
Max. power dissipation	$P_D$	125	W
Operating and storage temperature range	$T_{ch}$	150	$^\circ C$
	$T_{sig}$	$-55 \sim +150$	$^\circ C$

Equivalent Circuit Schematic

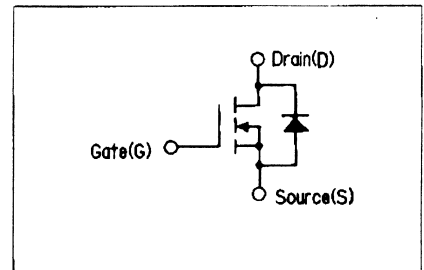

Electrical Characteristics ( $T_c = 25^\circ C$ )

Items	Symbols	Test Conditions	Min.	Typ.	Max.	Units
Drain-source breakdown voltage	$V_{(DR)DSS}$	$I_D = 1mA$ $V_{GS} = 0V$	800			V
Gate threshold voltage	$V_{GS(th)}$	$I_D = 1mA$ $V_{DS} = V_{GS}$	2.5	3.5	5.0	V
Zero gate voltage drain current	$I_{DSS}$	$V_{DS} = 800V$ $V_{GS} = 0V$	$T_{ch} = 25^\circ C$	10	500	$\mu A$
			$T_{ch} = 125^\circ C$	0.2	1.0	mA
Gate-source leakage current	$I_{GSS}$	$V_{GS} = \pm 30V$ $V_{DS} = 0V$		10	100	nA
Drain-source on-state resistance	$R_{DS(on)}$	$I_D = 3A$ $V_{GS} = 10V$		1.7	2.2	$\Omega$
Forward transconductance	$g_{fs}$	$I_D = 3A$ $V_{DS} = 25V$	2.0	4.5		S
Input capacitance	$C_{iss}$	$V_{DS} = 25V$		1200	1800	pF
Output capacitance	$C_{oss}$	$V_{GS} = 0V$		140	210	
Reverse transfer capacitance	$C_{rss}$	$f = 1MHz$		50	75	
Turn-on time $t_{on}$ ( $t_{on} + t_{a(on)} + t_r$ )	$t_{d(on)}$	$V_{CC} = 600V$ $I_D = 10A$ $V_{GS} = 10V$ $R_G = 25\Omega$		35	55	ns
	$t_r$			110	170	
Turn-off time $t_{off}$ ( $t_{d(off)} + t_r$ )	$t_{d(off)}$			150	230	
	$t_r$			100	150	
Diode forward on-voltage	$V_{SD}$	$I_F = 2 \times I_{DR}$ $V_{GS} = 0V$ $T_{ch} = 25^\circ C$		1.0	1.5	V
Reverse recovery time	$t_{rr}$	$I_F = I_{DR}$ $di/dt = 100A/\mu s$ $T_{ch} = 25^\circ C$		800		ns

Thermal Characteristics

Items	Symbols	Test Conditions	Min.	Typ.	Max.	Units
Thermal Resistance	$R_{th(ch-a)}$	channel to air			35.0	$^\circ C/W$
	$R_{th(ch-c)}$	channel to case			1.0	$^\circ C/W$

