



Low Noise Regulated Charge Pump DC-DC Converter



FEATURES

- Constant high frequency (2MHz) operation
- 100mA output current
- Regulated output voltage (5V fixed CAT3200-5, Adjustable CAT3200)
- Low quiescent current (1.7mA typ.)
- Input voltage operation down to 2.7V
- Soft start, slew rate control
- Thermal overload shutdown protection
- Low value external capacitors (1μF)
- Foldback current overload protection
- Shutdown current less than 1μA
- CAT3200-5 in low profile (1mm thin) 6-lead TSOT-23 package
- CAT3200 in MSOP-8 package

APPLICATIONS

- 3V to 5V boost conversion
- White LED driver
- USB On-The-Go 5V supply
- Local 5V supply from lower rail
- Battery backup systems
- Handheld portable devices

DESCRIPTION

The CAT3200 and CAT3200-5 are switched capacitor boost converters that deliver a low noise, regulated output voltage. The CAT3200-5 gives a fixed regulated 5V output. The CAT3200 has an adjustable output using external resistors. The constant frequency 2MHz charge pump allows small 1μF ceramic capacitors to be used.

Maximum output loads of up to 100mA can be supported over a wide range of input supply voltages (2.7V to 4.5V) making the device ideal for battery-powered applications.

A shutdown control input allows the device to be placed in power-down mode, reducing the supply current to less than 1μA.

In the event of short circuit or overload conditions, the device is fully protected by both foldback current limiting and thermal overload detection. In addition, a soft start, slew rate control circuit limits inrush current during power-up.

The CAT3200-5 is available in a 6-lead, 1mm max thin SOT23 package. The CAT3200 is available in an 8-lead MSOP package.

TYPICAL APPLICATION

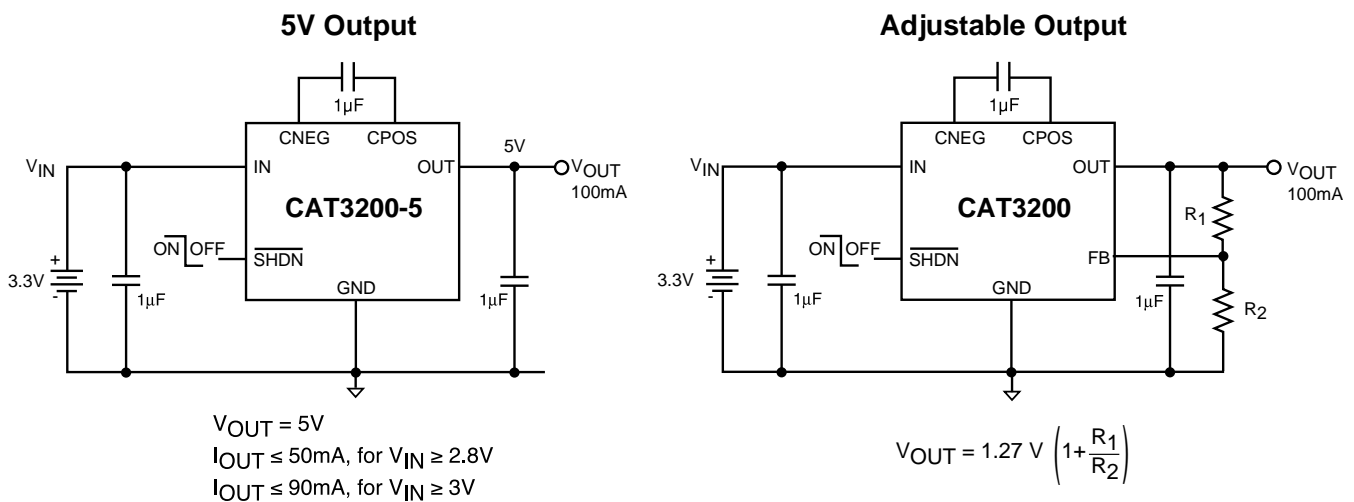

ORDERING INFORMATION

Part Number	Output Voltage	Package	Package Marking	Quantity per Reel
CAT3200TDI-T3	5V	6-lead thin SOT23, Lead Free	LN	3,000
CAT3200TDI-GT3	5V	6-lead thin SOT23, NiPdAu	VA	3,000
CAT3200ZI-T3	Adjustable	8-lead MSOP, Lead Free	ABME	3,000
CAT3200ZI-GT3	Adjustable	8-lead MSOP, NiPdAu	ABRU	3,000

PIN DESCRIPTIONS

Designation	Description
OUT	Regulated output voltage.
GND	Ground reference for all voltages.
$\overline{\text{SHDN}}$	Shutdown control logic input (Active LOW)
CNEG	Negative connection for the flying capacitor.
IN	Input power supply.
CPOS	Positive connection for the flying capacitor.
FB	Feedback to set the output voltage.
PGND	Power ground.
SGND	Signal ground.

PIN CONFIGURATION

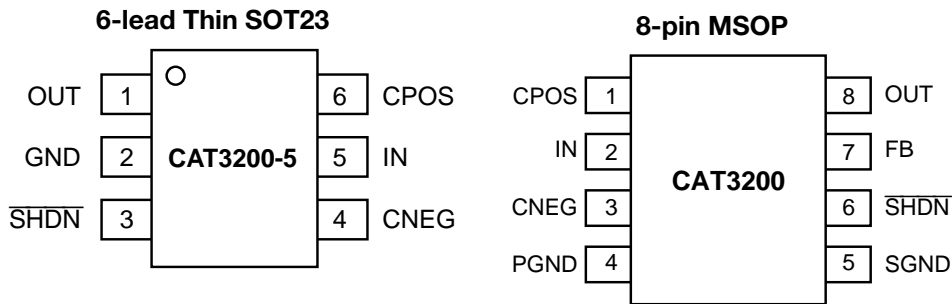

ABSOLUTE MAXIMUM RATINGS

V_{IN} , V_{OUT} , \overline{SHDN} , C_{NEG} , C_{POS} Voltage .. -0.6V to 6.0V
 V_{OUT} Short Circuit Duration Indefinite
 Output Current 200mA
 ESD Protection (HBM) 2000V
 Junction Temperature 150°C
 Storage Temperature Range -65°C to 160°C
 Lead Soldering Temperature (10 sec) 300°C
 Power Dissipation (SOT23-6) 0.3W

Power Dissipation (8-MSOP) 0.5W

RECOMMENDED OPERATING CONDITIONS

V_{IN} 2.7V to 4.5V
 C_{IN} , C_{OUT} , C_{FLY} 1 μ F
 I_{LOAD} 0 to 100mA
 Ambient Temperature Range -40°C to 85°C

ELECTRICAL SPECIFICATIONS

Recommended operating conditions unless otherwise specified. C_{IN} , C_{OUT} , C_{FLY} are 1 μ F ceramic capacitors and V_{IN} is set to 3.6V.

Symbol	Parameter	Conditions	Min	Typ	Max	Units
V_{OUT}	Regulated Output	$I_{LOAD} \leq 40mA$, $V_{IN} \geq 2.7V$ $I_{LOAD} \leq 100mA$, $V_{IN} \geq 3.1V$	4.8	5.0	5.2	V
V_{LINE}	Line Regulation	$3.1V \leq V_{IN} \leq 4.5V$, $I_{LOAD} = 50mA$		6		mV
V_{LOAD}	Load Regulation	$I_{LOAD} = 10mA$ to 100mA, $V_{IN} = 3.6V$		20		mV
F_{OSC}	Switching Frequency		1.3	2.0	2.6	MHz
V_R	Output Ripple Voltage	$I_{LOAD} = 100mA$ CAT3200-5 Only		30		mVp-p
η	Efficiency	$I_{LOAD} = 50mA$, $V_{IN} = 3V$, CAT3200-5		80		%
I_{GND}	Ground Current	$I_{LOAD} = 0mA$, $\overline{SHDN} = V_{IN}$		1.6	4	mA
I_{SHDN}	Shutdown Input Current	$I_{LOAD} = 0mA$, $\overline{SHDN} = 0V$ to V_{IN}			1	μ A
V_{FB}	FB Voltage	CAT3200 Only	1.22	1.27	1.32	V
I_{FB}	FB Input Current	CAT3200 Only	-50		50	nA
R_{OL}	Open-Loop Resistance	$I_{LOAD} = 100mA$, $V_{IN} = 3V$ (Note 1)		10		Ω
T_{ON}	V_{OUT} Turn-on time (10% to 90%)	$I_{LOAD} = 0mA$, $V_{IN} = 3V$		0.5		ms
V_{IHSHDN}	High Detect Shutdown Threshold			0.8	1.3	V
V_{ILSHDN}	Low Detect Shutdown Threshold		0.4			V
I_{ROUT}	Reverse Leakage into OUT pin	$V_{OUT} = 5V$, Shutdown mode (Note 2)		15	30	μ A
I_{SC}	Short-circuit Output	$V_{OUT} = 0V$		80		mA
T_{SD}	Thermal Shutdown			160		°C
T_{HYST}	Thermal Hysteresis			20		°C

Note 1: $R_{OL} = (2V_{IN} - V_{OUT})/I_{OUT}$

Note 2: In the event of a controlled shutdown, the output will be isolated from the input, but will remain connected to the internal resistor feedback network. This will cause a small level of reverse current to flow back into the device to ground.

TYPICAL PERFORMANCE CHARACTERISTICS (CAT3200-5)

$T_{AMB}=25^{\circ}\text{C}$, $C_{IN}=C_{OUT}=C_{FLY}=1\mu\text{F}$, $V_{IN}=3.3\text{V}$ unless specified otherwise.

Shutdown Input Threshold vs. Supply Voltage

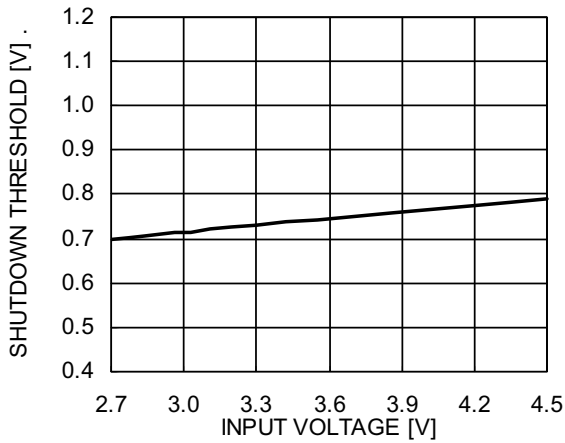

Ground Current vs. Supply Voltage (No Load)

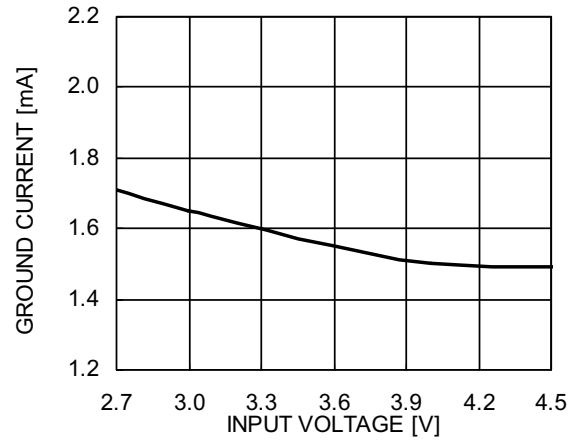

Line Regulation

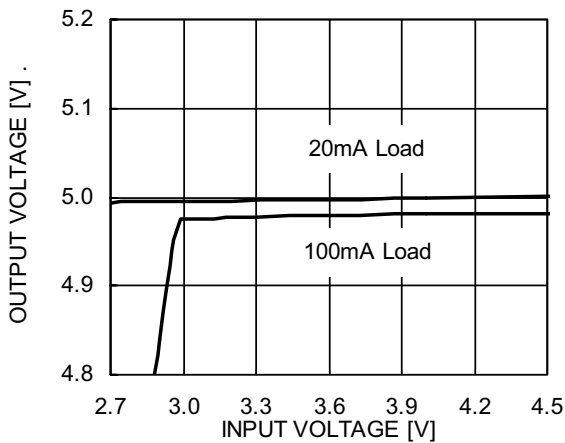

Load Regulation

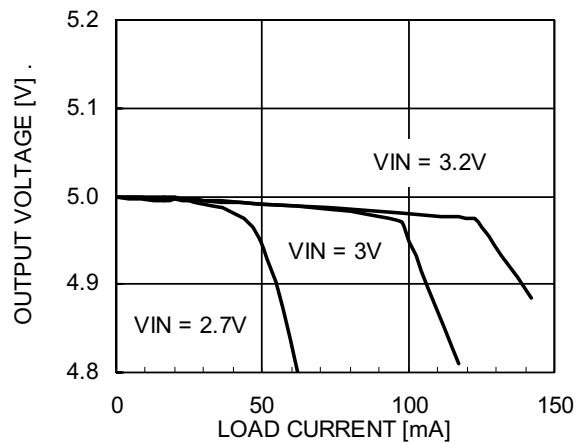

Oscillator Frequency vs. Supply Voltage

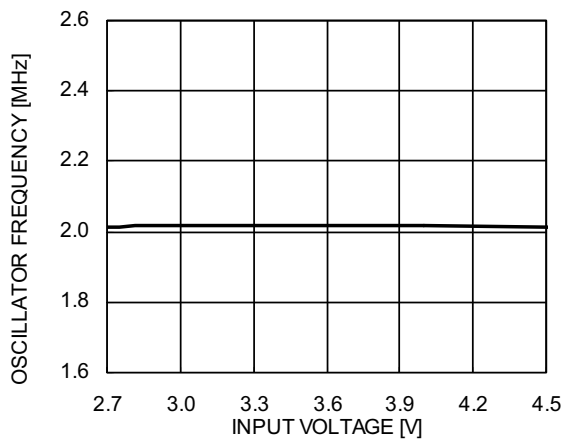

Efficiency vs. Load Current

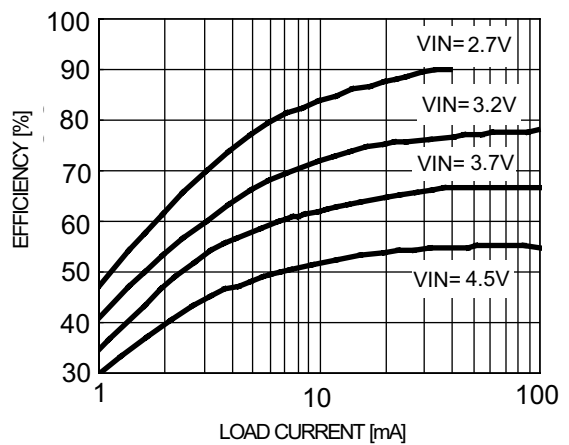

TYPICAL PERFORMANCE CHARACTERISTICS (CAT3200-5)

$T_{AMB}=25^{\circ}\text{C}$, $C_{IN}=C_{OUT}=C_{FLY}=1\mu\text{F}$, $V_{IN}=3.3\text{V}$ unless specified otherwise.

Soft Start Power Up (90mA Load, 3.3V Input)

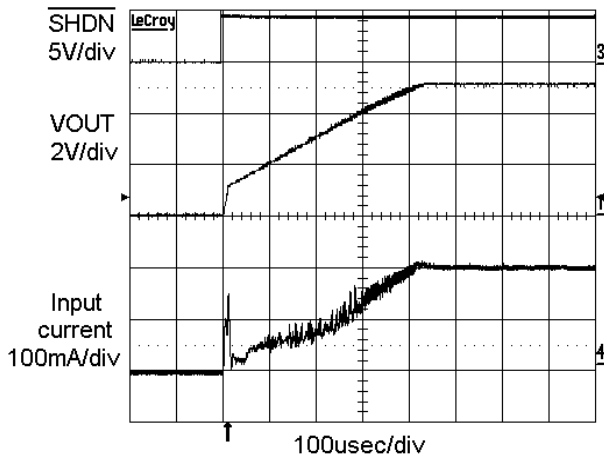

Load Step Response (3.3V Input)

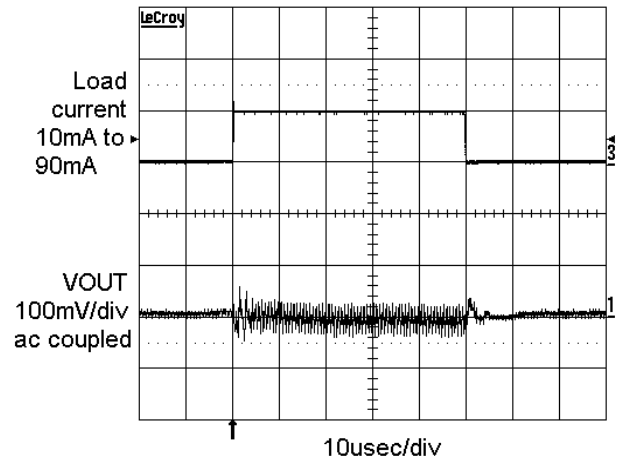

Output Ripple (100mA Load, 3.3V Input)

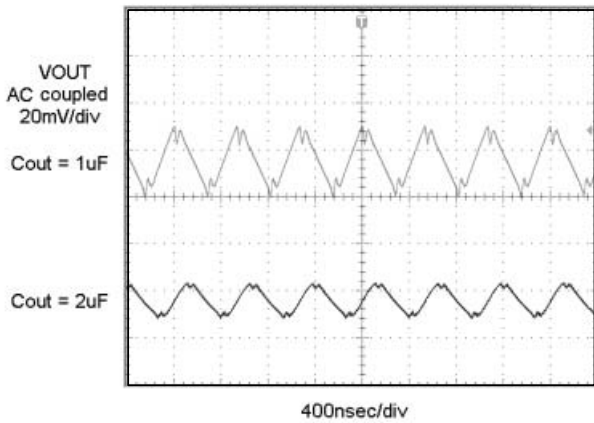

Short Circuit Current vs Supply Voltage

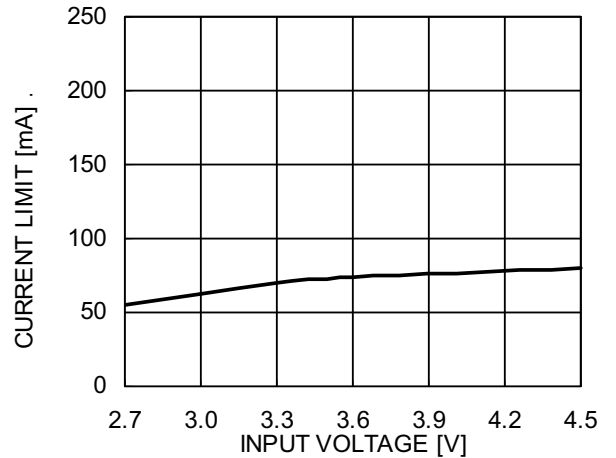

Output Voltage Change vs. Temperature

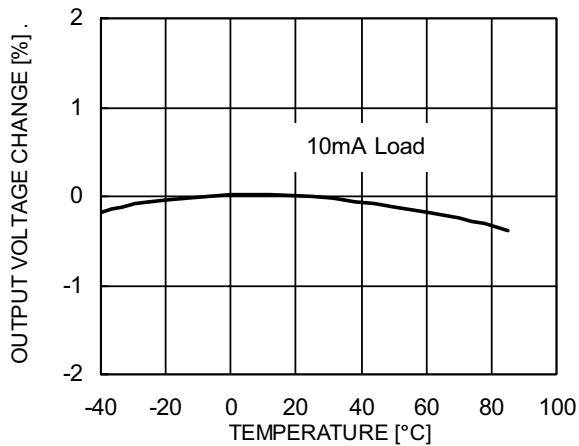

Oscillator Frequency Change vs. Temperature

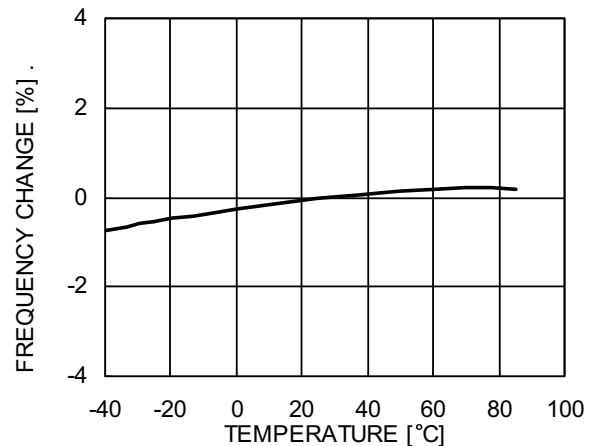

BLOCK DIAGRAM

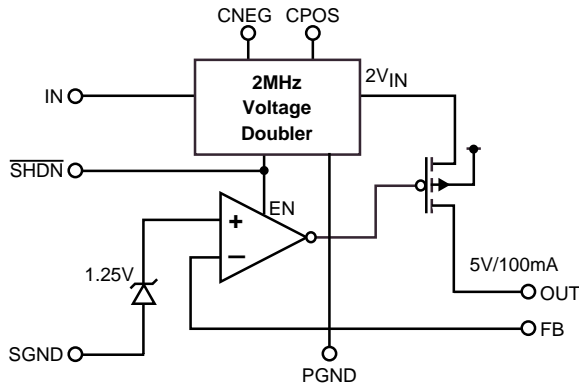

CAT3200 Adjustable Output

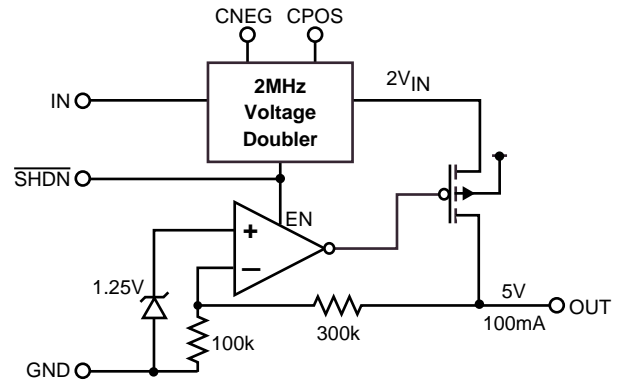

CAT3200-5 5V Fixed Output

PIN FUNCTIONS

IN is the power supply. During normal operation the device draws a supply current which is almost constant. A very brief interval of non-conduction will occur at the switching frequency. The duration of the non-conduction interval is set by the internal non-overlapping “break-before-make” timing. **IN** should be bypassed with a $1\mu\text{F}$ to $4.7\mu\text{F}$ low ESR (Equivalent Series Resistance) ceramic capacitor.

For filtering, a low ESR ceramic bypass capacitor ($1\mu\text{F}$) in close proximity to the **IN** pin prevents noise from being injected back into the power supply.

SHDN is the logic control input (Active LOW) that places the device into shutdown mode. The internal logic is CMOS and the pin does not use an internal pull-down resistor. The **SHDN** pin should not be allowed to float.

CPOS, **CNEG** are the positive and negative connections respectively for the charge pump flying capacitor. A low ESR ceramic capacitor ($1\mu\text{F}$) should be connected between these pins. During initial power-up it may be possible for the capacitor to experience a voltage reversal and for this reason, avoid using a polarized (tantalum or aluminum) flying capacitor.

OUT is the regulated output voltage to power the load. During normal operation, the device will deliver a train of current pulses to the pin at a frequency of 2MHz. Adequate filtering on the pin can typically be achieved through the use of a low ESR ceramic bypass capacitor ($1\mu\text{F}$ to $4.7\mu\text{F}$) in close proximity to the **OUT** pin. The ESR of the output capacitor will directly influence the output ripple voltage.

When the shutdown mode is entered, the output is immediately isolated from the input supply, however, the output will remain connected to the internal feedback

resistor network ($400\text{k}\Omega$). The feedback network will result in a reverse current of $10\mu\text{A}$ to $20\mu\text{A}$ to flow back through the device to ground.

Whenever the device is taken out of shutdown mode, the output voltage will experience a slew rate controlled power-up. Full operating voltage is typically achieved in less than 0.5 msec.

GND is the ground reference for all voltages on CAT3200-5 devices.

FB (CAT3200 Only) is the feedback input pin. An output divider should be connected from **OUT** to **FB** to program the output voltage.

PGND (CAT3200 Only). Is the same as **GND** for the CAT3200-5 except for the internal reference connection to **SGND**.

SGND (CAT3200 Only) Ground pin for the internal reference. The **CNEG** connection is switched to this pin during the normal charge pump operation.

DEVICE OPERATION

The CAT3200/CAT3200-5 use a switched capacitor charge pump to boost the voltage at IN to a regulated output voltage. Regulation is achieved by sensing the output voltage through an internal resistor divider (CAT3200-5) and modulating the charge pump output current based on the error signal. A 2-phase non-overlapping clock activates the charge pump switches. The flying capacitor is charged from the IN voltage on the first phase of the clock. On the second phase of the clock it is stacked in series with the input voltage and connected to OUT. The charging and discharging the flying capacitor continues at a free running frequency of typically 2MHz.

In shutdown mode all circuitry is turned off and the CAT3200/CAT3200-5 draw only leakage current from the V_{IN} supply. OUT is disconnected from IN. The \overline{SHDN} pin is a CMOS input with a threshold voltage of approximately 0.8V. The CAT3200/CAT3200-5 is in shutdown when a logic LOW is applied to the \overline{SHDN} pin. The \overline{SHDN} pin is a high impedance CMOS input. \overline{SHDN} does not have an internal pull-down resistor and should not be allowed to float and. It must always be driven with a valid logic level.

Short-Circuit and Thermal Protection

The CAT3200 and CAT3200-5 have built-in short-circuit current limiting and over temperature protection. During overload conditions, output current is limited to approximately 225mA. At higher temperatures, or if the input voltage is high enough to cause excessive chip self heating, the thermal shutdown circuit shuts down the charge pump as the junction temperature exceeds approximately 160°C. Once the junction temperature drops back to approximately 140°C, the charge pump is enabled. The CAT3200 and CAT3200-5 will cycle in and out of thermal shutdown indefinitely without latch-up or damage until a short-circuit on OUT is removed.

Programming the CAT3200 Output Voltage (FB Pin)

The CAT3200-5 version has an internal resistive divider to program the output voltage. The programmable CAT3200 may be set to an arbitrary voltage via an external resistive divider. Since it employs a voltage doubling charge pump, it is not possible to achieve output voltages greater than twice the available input voltage. Figure 1 shows the required voltage divider connection. The voltage divider ratio is given by the formula:

$$\frac{R1}{R2} = \frac{V_{OUT}}{1.27V} - 1$$

Typical values for total voltage divider resistance can range from several kΩs up to 1MΩ.

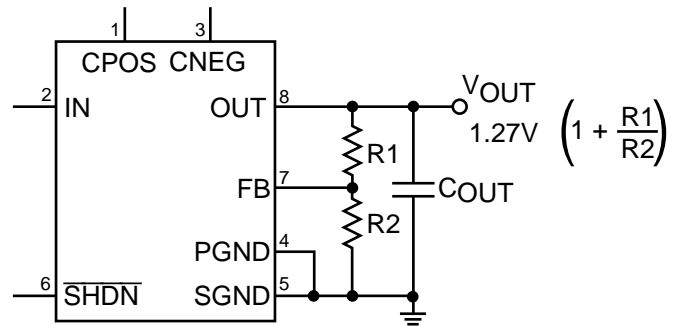

Figure 1: Programming the Adjustable CAT3200

APPLICATION INFORMATION

Ceramic Capacitors

Ceramic capacitors of different dielectric materials lose their capacitance with higher temperature and voltage at different rates. For example, a capacitor made of X5R or X7R material will retain most of its capacitance from – 40°C to 85°C whereas a Z5U or Y5V style capacitor will lose considerable capacitance over that range.

Z5U and Y5V capacitors may also have voltage coefficient causing them to lose 60% or more of their capacitance when the rated voltage is applied. When comparing different capacitors it is often useful consider the amount of achievable capacitance for a given case size rather than discussing the specified capacitance value. For example, over rated voltage and temperature conditions, a 1µF, 10V, Y5V ceramic capacitor in an 0603 case may not provide any more capacitance than a 0.22µF, 10V, X7R available in the same 0603 case. For many CAT3200/CAT3200-5 applications these capacitors can be considered roughly equivalent.

The capacitor manufacturer’s data sheet should be consulted to determine what value of capacitor is needed to ensure the desired capacitance at all temperatures and voltages. Below is a list of ceramic capacitor manufacturers and how to contact them:

Capacitor Manufacturer	Web	Phone
Murata	www.murata.com	814.237.1431
AVX/Kemet	www.avxcorp.com	843.448.9411
Vishay	www.vishay.com	
Kemet	www.kemet.com	408.986.0424
Taiyo Yuden	www.t-yuden.com	408.573.4150

Thermal Management

For higher input voltages and maximum output current there can be substantial power dissipation in the CAT3200/CAT3200-5. If the junction temperature increases to 160°C, the thermal shutdown circuitry will automatically turn off the output.

A good thermal connection to the PC board is recommended to reduce the chip temperature. Connecting the GND pin (Pins 4/5 for CAT3200, Pin 2 for CAT3200-5) to a ground plane, and maintaining a solid ground plane under the device reduces the overall thermal resistance.

The overall junction to ambient thermal resistance (θ_{JA}) for device power dissipation (P_D) consists primarily of two paths in series. The first path is the junction to the case (θ_{JC}) which is defined by the package style, and the second path is case to ambient (θ_{CA}) thermal resistance which is dependent on board layout. The final operating junction temperature for any set of conditions can be estimated by the following thermal equation:

$$T_{JUNC} = T_{AMB} + P_D(\theta_{JC}) + P_D(\theta_{CA})$$

$$= T_{AMB} + P_D(\theta_{JA})$$

The CAT3200 in SOT23 package, when mounted on printed circuit board with two square inches of copper allocated for “heat spreading”, will result with an overall θ_{JA} of less than 150°C/W.

For a typical application operating from a 3.8V input supply, the maximum power dissipation is 260mW (100mA x 3V). This would result if a maximum junction temperature of :

$$T_{JUNC} = T_{AMB} + P_D(\theta_{JA})$$

$$= 85^\circ\text{C} + 0.26\text{W}(150^\circ\text{C/W})$$

$$= 85^\circ\text{C} + 39^\circ\text{C} = 124^\circ\text{C}$$

The use of multi-layer board construction with power planes will further enhance the overall thermal performance. In the event of no dedicated copper area being used for heat spreading, a multi-layer board will typically provide the CAT3200 with an overall θ_{JA} of 200°C/W. This level of thermal conduction would allow up to 200mW be safely dissipated within the device.

TYPICAL APPLICATIONS

3.3 V Supply to 5 V

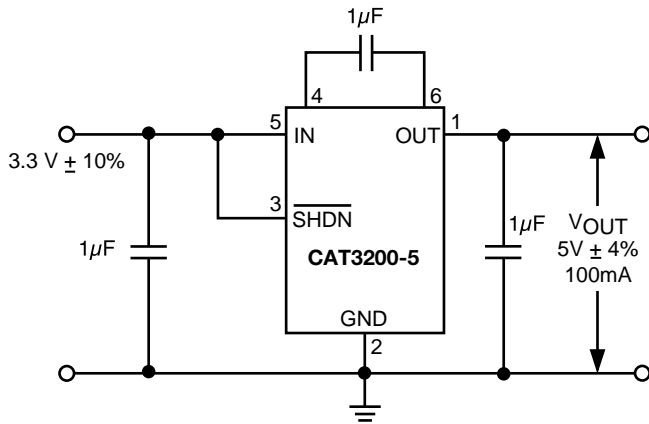

USB Port to Regulated 5V Power Supply

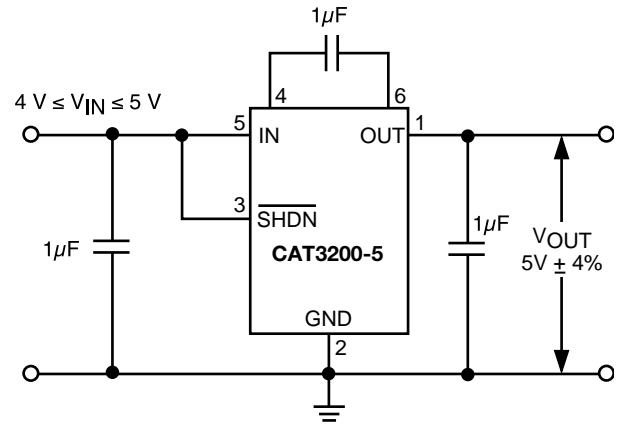

Lithium-Ion Battery to 5V White or Blue LED Driver

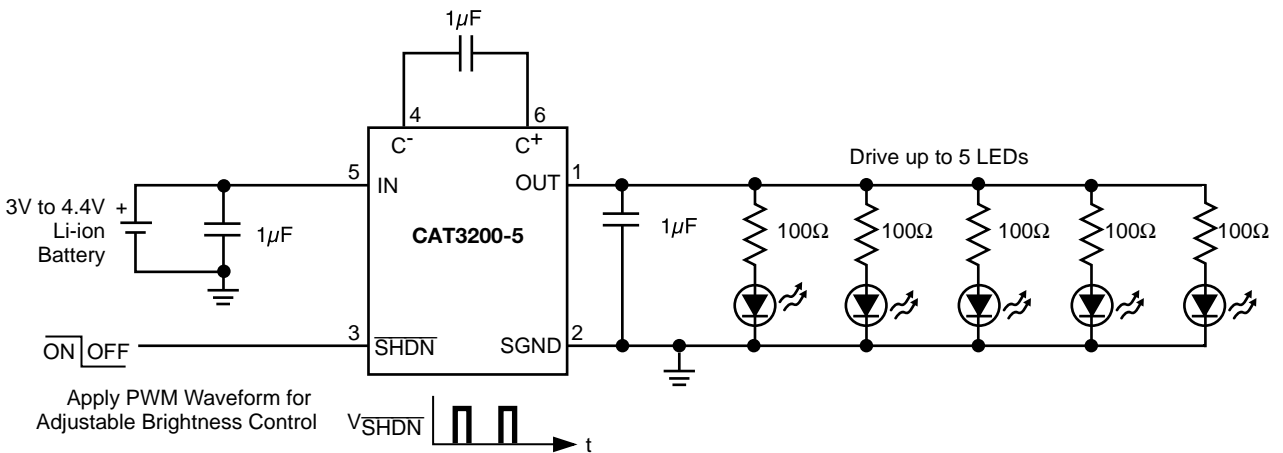

White or Blue LED Driver with LED Current Control

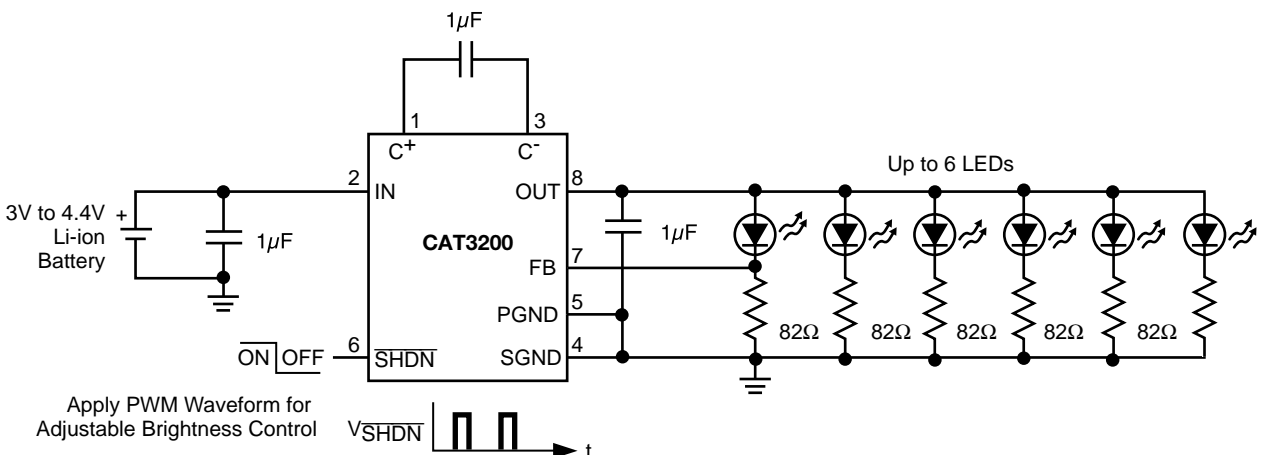

PACKAGE OUTLINE DRAWING

TSOT-23 6-Lead (TD)⁽¹⁾⁽²⁾

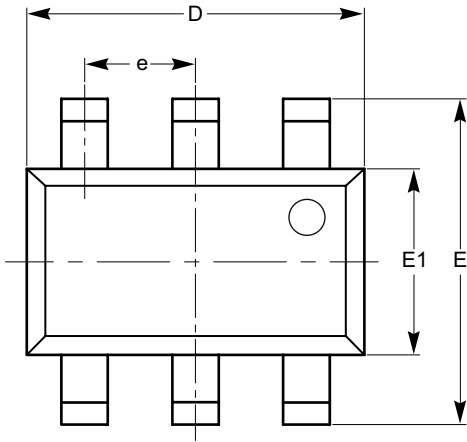

TOP VIEW

SYMBOL	MIN	NOM	MAX
A			1.00
A1	0.01	0.05	0.10
A2	0.80	0.87	0.90
b	0.30		0.45
c	0.12	0.15	0.20
D	2.90 BSC		
E	2.80 BSC		
E1	1.60 BSC		
e	0.95 TYP		
L	0.30	0.40	0.50
L1	0.60 REF		
L2	0.25 BSC		
θ	0°		8°

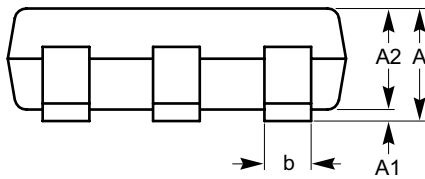

SIDE VIEW

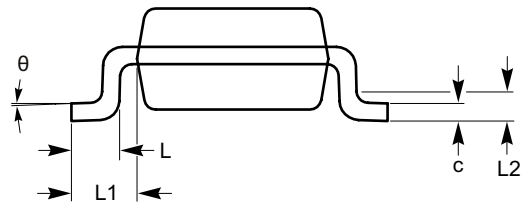

END VIEW

For current Tape and Reel information, download the PDF file from:
<http://www.catsemi.com/documents/tapeandreel.pdf>.

Note:

- (1) All dimensions are in millimeters. Angles in degrees.
- (2) Complies with JEDEC standard MO-193.

MSOP 8-Lead 3.0 x 3.0mm (Z)⁽¹⁾⁽²⁾

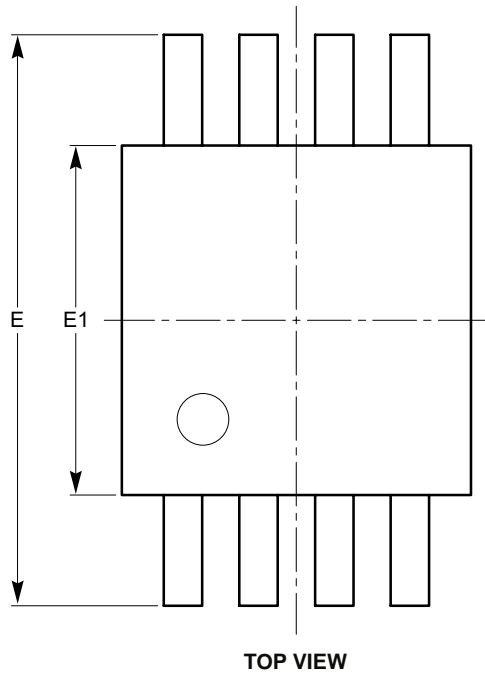

SYMBOL	MIN	NOM	MAX
A			1.10
A1	0.05	0.10	0.15
A2	0.75	0.85	0.95
b	0.22		0.38
c	0.13		0.23
D	2.90	3.00	3.10
E	4.80	4.90	5.00
E1	2.90	3.00	3.10
e	0.65 BSC		
L	0.40	0.60	0.80
L1	0.95 REF		
L2	0.25 BSC		
θ	0°		6°

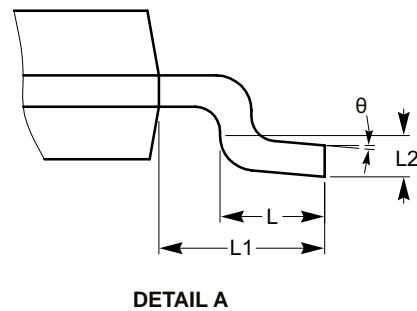
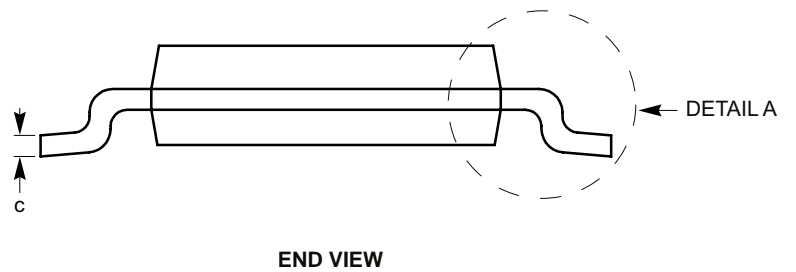
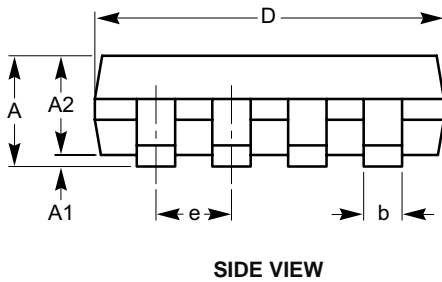

For current Tape and Reel information, download the PDF file from:
<http://www.catsemi.com/documents/tapeandreeel.pdf>

Note:
 (1) All dimensions are in millimeters. Angles in degrees.
 (2) Complies with JEDEC standard MO-187.

EXAMPLE OF ORDERING INFORMATION

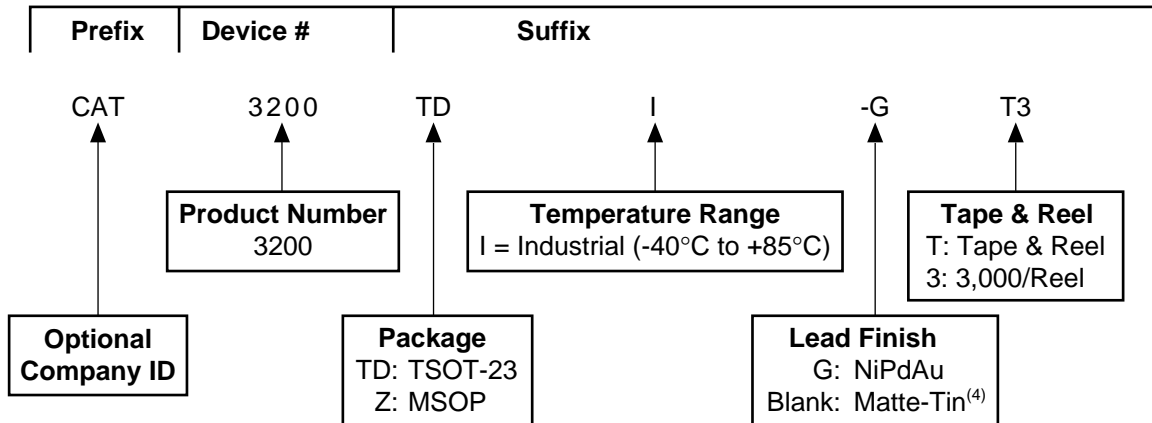

Notes:

- (1) All packages are RoHS-compliant (Lead-free, Halogen-free).
- (2) The standard lead finish is NiPdAu.
- (3) The device used in the above example is a CAT3200TDI-GT3 (TSOT-23, Industrial, NiPdAu, Tape & Reel, 3,000/Reel).
- (4) For Matte-Tin package option, please contact your nearest ON Semiconductor sales office.

REVISION HISTORY

Date	Rev.	Reason
17-Jun-04	A	Initial Release
03-Sep-04	B	Update Ordering Information
23-Sep-04	C	Minor change
26-Oct-04	D	Removed TDFN package, minor changes
29-Oct-04	E	Added Green Packages
01-Feb-05	F	Update 6-lead SOT-23 mechanical package drawing
28-Feb-05	G	Update Ordering Information
18-Mar-05	H	Update Ordering Information
22-Sep-05	I	Update Ordering Information
11-Jan-06	J	Update Ordering Information
01-Aug-06	K	Change MSOP Tape&Reel
29-Oct-07	L	Update Ordering Information Update Package Outline Drawings Add MD- to Document Number
17-Nov-08	M	Change logo and fine print to ON Semiconductor
05-Jan-09	N	Update Ordering Information with VA package Add Example of Ordering Information

ON Semiconductor and  are registered trademarks of Semiconductor Components Industries, LLC (SCILLC). SCILLC reserves the right to make changes without further notice to any products herein. SCILLC makes no warranty, representation or guarantee regarding the suitability of its products for any particular purpose, nor does SCILLC assume any liability arising out of the application or use of any product or circuit, and specifically disclaims any and all liability, including without limitation special, consequential or incidental damages. "Typical" parameters which may be provided in SCILLC data sheets and/or specifications can and do vary in different applications and actual performance may vary over time. All operating parameters, including "Typicals" must be validated for each customer application by customer's technical experts. SCILLC does not convey any license under its patent rights nor the rights of others. SCILLC products are not designed, intended, or authorized for use as components in systems intended for surgical implant into the body, or other applications intended to support or sustain life, or for any other application in which the failure of the SCILLC product could create a situation where personal injury or death may occur. Should Buyer purchase or use SCILLC products for any such unintended or unauthorized application, Buyer shall indemnify and hold SCILLC and its officers, employees, subsidiaries, affiliates, and distributors harmless against all claims, costs, damages, and expenses, and reasonable attorney fees arising out of, directly or indirectly, any claim of personal injury or death associated with such unintended or unauthorized use, even if such claim alleges that SCILLC was negligent regarding the design or manufacture of the part. SCILLC is an Equal Opportunity/Affirmative Action Employer. This literature is subject to all applicable copyright laws and is not for resale in any manner.

PUBLICATION ORDERING INFORMATION

LITERATURE FULFILLMENT:

Literature Distribution Center for ON Semiconductor
P.O. Box 5163, Denver, Colorado 80217 USA
Phone: 303-675-2175 or 800-344-3860 Toll Free USA/Canada
Fax: 303-675-2176 or 800-344-3867 Toll Free USA/Canada
Email: orderlit@onsemi.com

N. American Technical Support: 800-282-9855
Toll Free
USA/Canada

Europe, Middle East and Africa Technical Support:
Phone: 421 33 790 2910

Japan Customer Focus Center:
Phone: 81-3-5773-3850

ON Semiconductor Website: www.onsemi.com

Order Literature: <http://www.onsemi.com/orderlit>

For additional information, please contact your local Sales Representative