

VORTEX FLOWMETER (Eggs DELTA)

DATA SHEET

FMP, M

This instrument is a Karman vortex flowmeter made of PPS resin that can be used both for liquid and gas. It has no moving parts. It does not shut the flow even in the case of an emergency, which makes it most suitable for not only in general flow control applications but also in important washing processes and cooling processes, and in the terminal consumption control such as in factory air control. The exclusive monitoring instrument is a battery charged type and does not need external power supply. Orientation of the indicator can be adjusted freely to easy-to-see direction.

FEATURES

1. The monitoring mode can be changed freely from total flow monitoring to instantaneous flow rate monitoring, and vice versa, by an externally mounted mode switch.
2. A rainproof type is available for outdoor use as well as for indoor use.
3. The highly durable structure with no moving parts does not impose limitations to its mounting positions.
4. The instrument is highly resistive to fouling by fluid, and its structure facilitates cleaning of its interior.
5. Remotely controllable external output (total pulse or instantaneous analog) is available.



SPECIFICATIONS (TYPE: FMP)

Item		Description			
Type	For liquid	FMP2S	FMP20	FMP21	FMP22
	For gas	FMP3S	FMP30	FMP31	FMP32
Nominal diameter, connection		4mm R ³ / ₈ male screw or Rc ¹ / ₄ female screw	8mm R ¹ / ₂ male screw or Rc ¹ / ₄ female screw	15mm R ³ / ₄ male screw or Rc ¹ / ₂ female screw	25mm R ¹ / ₄ male screw or Rc1 female screw
Fluid	For liquid	Water, pure water, or others (non-corrosive, non-inflammable)			
	For gas	Air, nitrogen, oxygen, argon, or others (non-inflammable gas)			
Flow rate range (L/min) *	Water	0.4 to 4	1.17 to 15	2.8 to 45	8.3 to 133
	Air	7.2 to 17	18 to 90	55 to 283	167 to 850
Permissible ambient temperature range	Fluid	-10 to +80°C (no condensation allowed)			
	Environment	-20 to +50°C			
Maximum pressure		0.98MPa			
Accuracy		±3% of full-scale measurement (see Fig. 1)			
Reproducibility		±0.5%			
Length of straight pipe		Upstream side: 7D or more, downstream side: 3D or more (see Fig. 2)			
Pressure loss (kPa) [see Fig. 1]	Water	0.31 to 31	0.12 to 34.3		
	Air	0.13 to 0.7	0.06 to 1.52		
Main body material		PPS resin (polyphenylene sulfide)			
Indicator (LCD digital display)		(1) Total flow: 8 digits (2) Instantaneous flow rate (per hour): 5 digits (3) Instantaneous flow rate (per minute): 5 digits (4) Resettable total flow: 7 digits			
		(1), (2), (3), or (4) can be selected by push button. Flow rate unit [L, m ³ , g, kg, t, L (normal), m ³ (normal)] and decimal point are indicated on LCD. (Orientation of the indicator can be adjusted freely over 360°.) * Alarm is indicated with LED (red).			
Output signal	Battery type	None			
	Externally energized type	4 to 20 mA DC analog (instantaneous flow rate) (see Fig. 3 Load Resistance Range); or Pulse output (open collector). Rated values: 30 V DC, 20 mA. ON voltage: 1 V or less. Pulse width: 30 ms (correct pulse) or 1 ms (non-correct pulse). ... If with indicator Duty ratio about 1:1 (non-correct pulse) ... If without indicator Alarm output (H, L) ... Open collector. Rated values: 30 V DC, 20 mA. ON voltage: 1 V or less.			
Cable		5-core shielded cable (1 m) ... if with indicator, for externally energized type 3-core shielded cable (1 m) ... if without indicator			
Power supply	Battery type	Lithium battery unit. Life time: 4 years (at normal temperature) ... With weak battery alarm function.			
	Externally energized type	12 to 45 V DC (type code 6th digit: 1) 12 to 24 V DC (type code 6th digit: 0)			
Structure		Outdoor use (rainproof type), non-explosion-proof type. Direct sunshine not allowed.			
Backup (if with indicator)		Parameter settings and total value are held in EEPROM			

*: Flow rate range may vary according to the viscosity, temperature, and pressure of the fluid.

CODE SYMBOLS

< Eggs DELTA >				4	5	6	7	8	9	10	← Digit		
Digit	Description	Note	FMP										
4	<Applicable fluid> Liquid Gas			2	3								
5	<Nominal diameter> 4mm equivalent 8mm equivalent 15mm equivalent 25mm equivalent			S	0	1	2						
6	<Indicator> With indicator					1							
7	<Output signal> Without (battery type) Correct pulse output Analog output Non-correct pulse output Upper/lower limit alarm output Output of correct pulse and upper/lower limit alarm Output of non-correct pulse and upper/lower limit alarm						0	1	2	3	4	5	6
8	<Modification No.>								2				
9	<Material of connection part> PPS (R male screw) SUS (Rc female screw)										P	S	
10	<Structure> Waterproof type												W

< Eggs DELTA Pulse >				4	5	6	7	8	9	10	← Digit		
Digit	Description	Note	FMP										
4	<Applicable fluid> Liquid Gas			2	3								
5	<Nominal diameter> 4mm equivalent 8mm equivalent 15mm equivalent 25mm equivalent				S	0	1	2					
6	<Indicator> Without					0							
7	<Output signal> Non-correct pulse output, dividing frequency 1/1 (for liquid) Non-correct pulse output, dividing frequency 1/10 (for gas) Non-correct pulse output, dividing frequency 1/100 (for special fluid)							7	8	9			
8	<Modification No.>								1				
9	<Material of connection part> PPS (R male screw) SUS (Rc female screw)										P	S	
10	<Structure> Waterproof type												W

INDICATION AND OUTPUT UNIT (STANDARD SETTING)

(1) Liquid

Nomal diameter (mm)	Units of integration and corrected output	Nominal output pulse unit (mL/P)	Instantaneous flow rate	
			1 L/h	0.01 L/min
4	0.01 L	0.08900	1 L/h	0.01 L/min
8	0.1 L	0.4408	10 L/h	0.1 L/min
15	1 L	2.363	100 L/h	1 L/min
25	1 L	12.66	100 L/h	1 L/min

(2) Gas

Nomal diameter (mm)	Units of integration and corrected output	Nominal output pulse unit (mL/P)	Instantaneous flow rate	
			10 L/h	0.1 L/min
4	0.1 L	0.8900	10 L/h	0.1 L/min
8	1 L	4.408	100 L/h	1 L/min
15	1 L	23.63	100 L/h	1 L/min
25	10 L	126.6	1000 L/h	10 L/min

INSTRUMENTAL DEVIATION AND PRESSURE LOSS [FIG. 1]

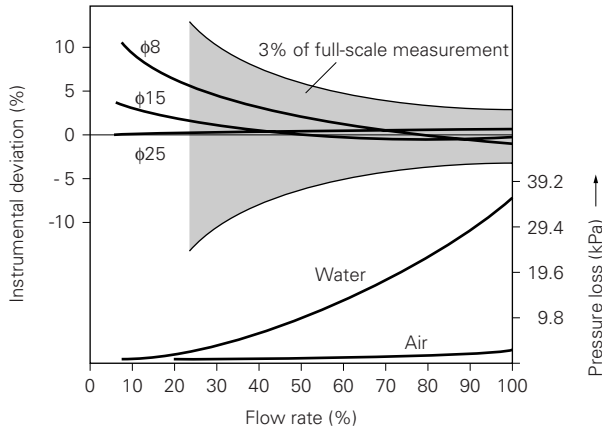

LOAD RESISTANCE RANGE [FIG. 3]

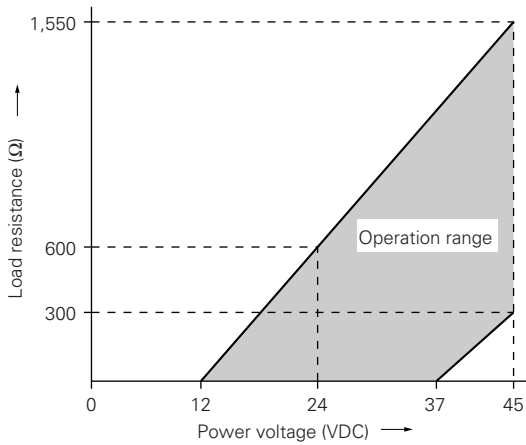

STRAIGHT PIPE LENGTH [FIG. 2]

As a rule, secure the straight pipe length of at least 7D upstream and 3D downstream (D: Flowmeter inner diameter). For actual straight pipe length, see table below. Pay attention to following items for securing the accuracy.

Nominal diameter (mm)	Inner diameter (mm)	Upstream (L1) (mm)	Downstream (L2) (mm)
4	8.5	59 or more	25 or more
8 (PPS)	13	91 or more	39 or more
8 (SCS14A)	8.5	59 or more	25 or more
15	14	98 or more	42 or more
25	24.5	171 or more	73 or more

- (1) Use a connecting pipe of an inner diameter same as or more than that of main body.
- (2) If there is "abrupt expansion of piping diameter" upstream the flowmeter such as metering valve, diffuser, etc., get at least 50D away.
- (3) Provide a regulating valve downstream the flowmeter.

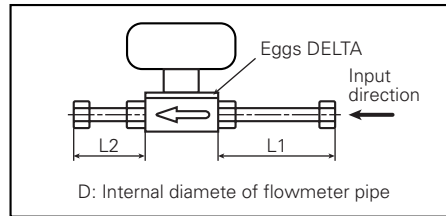

OUTLINE DIAGRAM (Unit: mm)

With indicator (Code symbol 6th digit:1)

Alarm 1 indicator LED * Alarm 2 indicator LED *

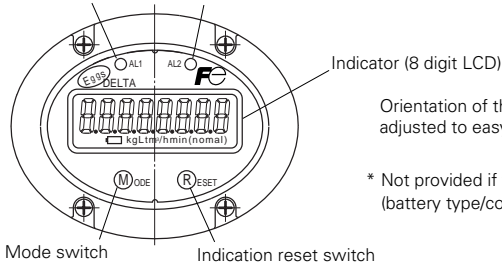

Indicator (8 digit LCD)
Orientation of the indicator can be adjusted to easy-to-see direction.

* Not provided if without output signal (battery type/code symbol 7th digit: 0)

< In case of PPS (R male screw) ... Code symbol 9th digit:P >

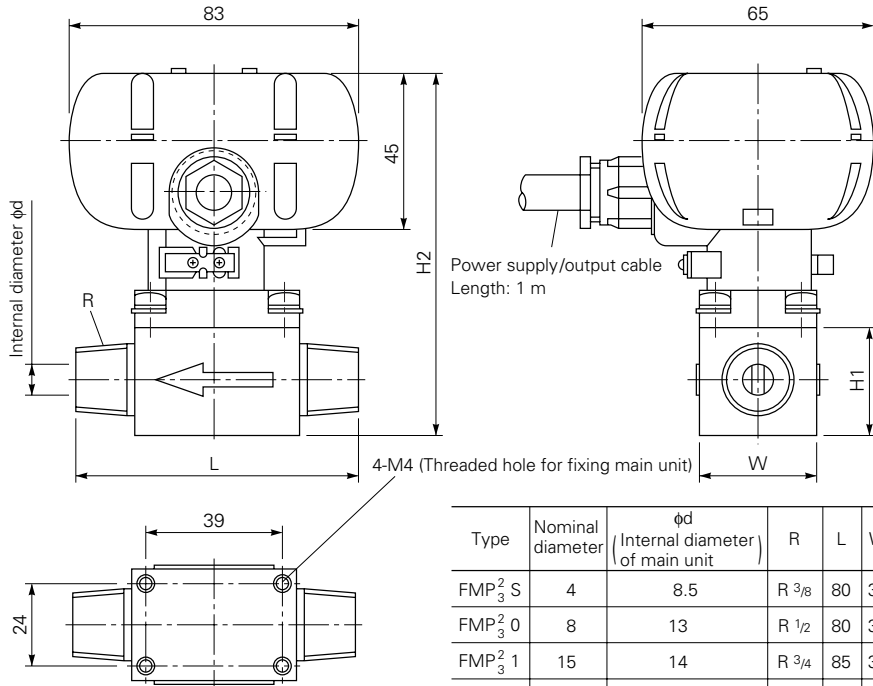

Type	Nominal diameter	ϕd (Internal diameter of main unit)	R	L	W	H1	H2	Mass (g)
FMP ₃ ² S	4	8.5	R ³ / ₈	80	32	29	102	285
FMP ₃ ² 0	8	13	R ¹ / ₂	80	32	29	102	285
FMP ₃ ² 1	15	14	R ³ / ₄	85	32	29	102	290
FMP ₃ ² 2	25	24.5	R ¹ / ₄	120	46	46	119	420

< In case of SUS (Rc female screw) ... Code symbol 9th digit:S >

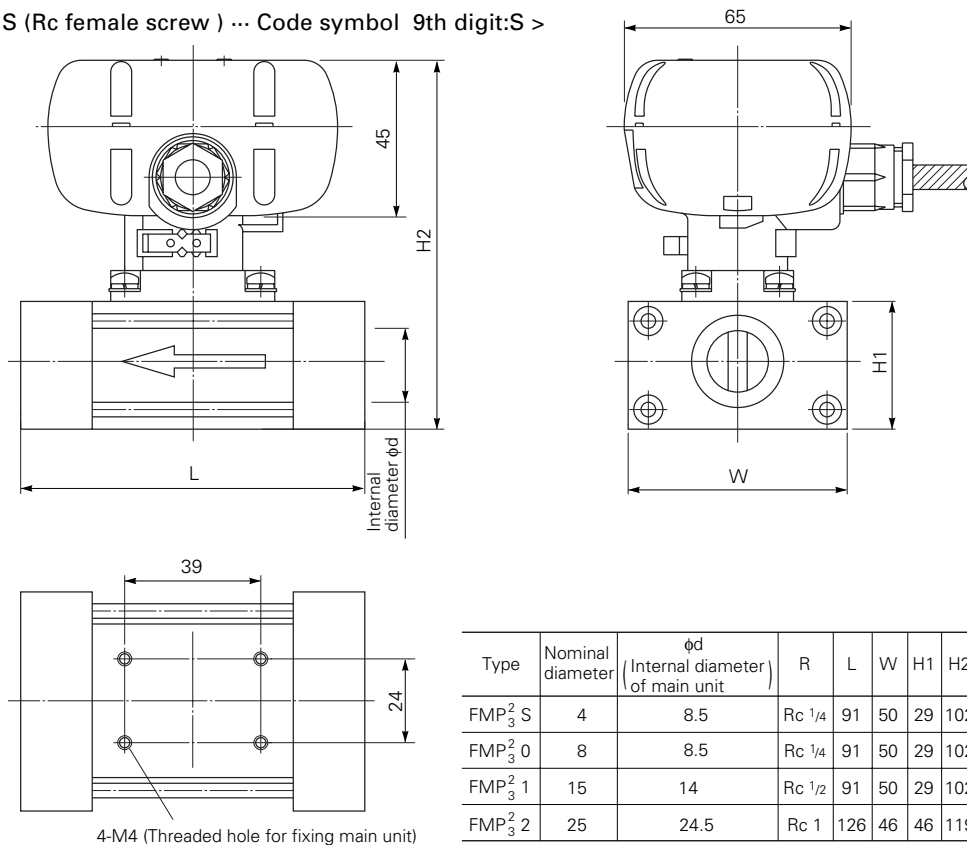

Type	Nominal diameter	ϕd (Internal diameter of main unit)	R	L	W	H1	H2	Mass (g)
FMP ₃ ² S	4	8.5	Rc ¹ / ₄	91	50	29	102	660
FMP ₃ ² 0	8	8.5	Rc ¹ / ₄	91	50	29	102	660
FMP ₃ ² 1	15	14	Rc ¹ / ₂	91	50	29	102	660
FMP ₃ ² 2	25	24.5	Rc 1	126	46	46	119	960

OUTLINE DIAGRAM (Unit: mm)

Without indicator (Code symbol 6th digit:0)

< In case of PPS (R male screw) ... Code symbol 9th digit:P >

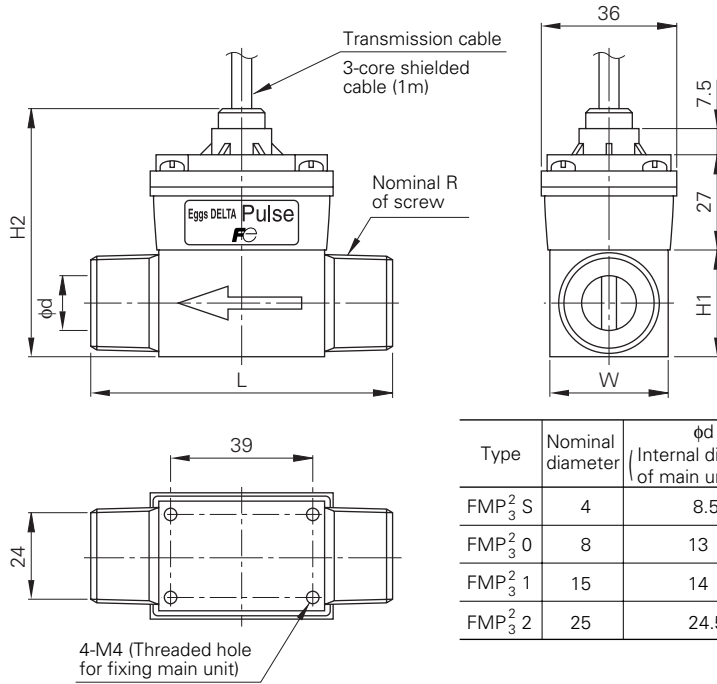

Type	Nominal diameter	ϕd (Internal diameter of main unit)	R	L	W	H1	H2	Mass (g)
FMP ₃ ² S	4	8.5	R 3/8	80	32	29	68	270
FMP ₃ ² 0	8	13	R 1/2	80	32	29	68	270
FMP ₃ ² 1	15	14	R 3/4	85	32	29	68	280
FMP ₃ ² 2	25	24.5	R 1 1/4	120	46	46	85	410

< In case of SUS (Rc female screw) ... Code symbol 9th digit:S >

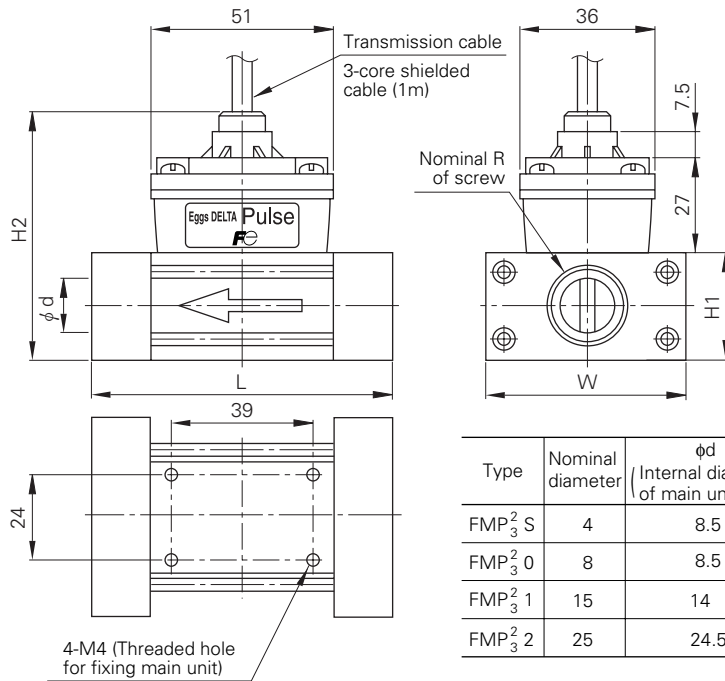

Type	Nominal diameter	ϕd (Internal diameter of main unit)	R	L	W	H1	H2	Mass (g)
FMP ₃ ² S	4	8.5	Rc 1/4	91	50	29	68	650
FMP ₃ ² 0	8	8.5	Rc 1/4	91	50	29	68	650
FMP ₃ ² 1	15	14	Rc 1/2	91	50	29	68	650
FMP ₃ ² 2	25	24.5	Rc 1	126	46	46	85	950

CONNECTION DIAGRAM (WITH 1m CABLE)

With indicator (Code symbol 6th digit:1)

<Analog output>

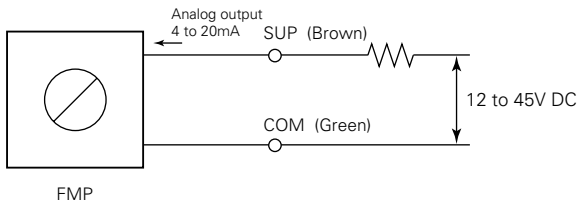

<Correct or non-correct pulse output>

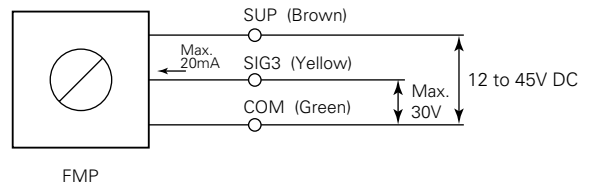

<Upper and lower limit alarm output>

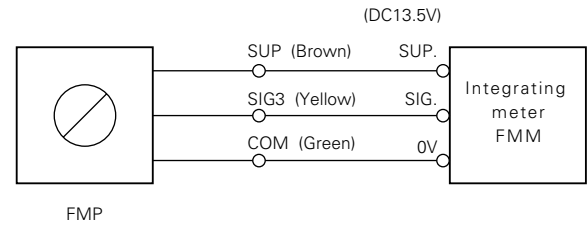
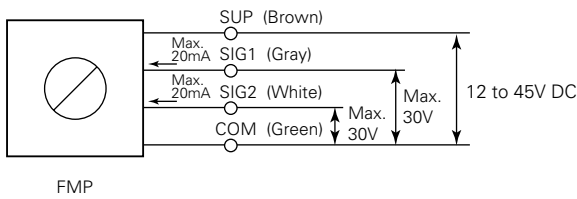

● Polarity

Wire color	Description
Brown	SUP (and analog output)
Gray	SIG. 1 ... Alarm 1 output (upper limit/lower limit)
White	SIG. 2 ... Alarm 2 output (upper limit/lower limit)
Yellow	SIG. 3 ... Correct/non-correct pulse output
Green	COM

<Correct or non-correct pulse output + upper and lower limit alarm output>

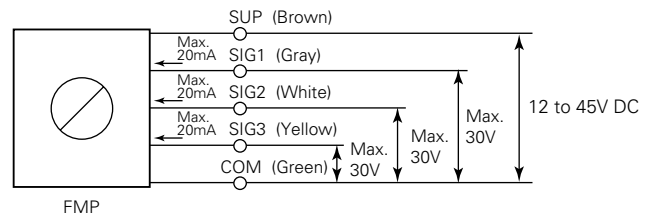

Note: Analog output and pulse output or upper/lower limit alarm cannot be combined.

Without indicator (Code symbol 6th digit:0)

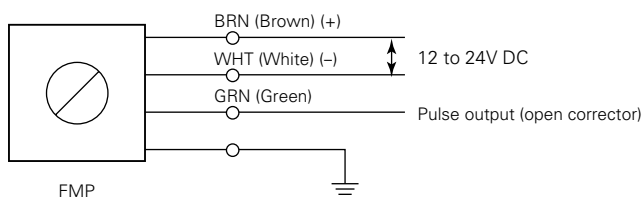

INTEGRATING METER (Type: FMM)

OVERVIEW

This instrument is a compact type LCD display counter that receives pulse signal from vortex flowmeter and indicates total flow and digital instantaneous flow rate (with power supply for the oscillator built in).



Flush mount type



Wall type

FEATURES

- One-chip CPU mounted on this instrument has permitted many functions.
Pressing pushbutton enables switching to the following 4 display modes.
① Total flow, ② Zero reset total, ③ Instantaneous flow rate (switching between per hour display and per minute display is possible.), ④ Meter coefficient
- This instrument has a function of a scaler and of a divider.
- It converts input pulse signal representing flow rate into an analog signal through built-in F/I conversion circuit. (Option)
- Equipped with pulse output before or after the correction

SPECIFICATIONS

Item	Description																																
Display method	LCD Height of letters: 12.7mm																																
Display Items to be displayed	Pressing "MODE" switch allows the following display modes to rotate. (Mode display such as b1, b2, and c is displayed on the most significant and the second digit of the display window.)																																
	<table border="1"> <thead> <tr> <th>Mode</th> <th>Display</th> <th>Digit</th> <th>Description</th> </tr> </thead> <tbody> <tr> <td>—</td> <td>Total flow</td> <td>8</td> <td>Not resettable to 0</td> </tr> <tr> <td>b1</td> <td>Instantaneous flow rate</td> <td>5</td> <td>Per hour **</td> </tr> <tr> <td>b2</td> <td>Instantaneous flow rate</td> <td>5</td> <td>Per minute **</td> </tr> <tr> <td>c</td> <td>Total flow</td> <td>7</td> <td>Resettable to 0</td> </tr> <tr> <td>d</td> <td>Divided value*</td> <td>1</td> <td>0 (1/1), 1 (1/10), 2 (1/100)</td> </tr> <tr> <td>F</td> <td>Meter coefficient*</td> <td>5</td> <td>0.0001 to 1.9999</td> </tr> <tr> <td>A</td> <td>Number of cycle samples</td> <td>3</td> <td>1 to 128</td> </tr> </tbody> </table>	Mode	Display	Digit	Description	—	Total flow	8	Not resettable to 0	b1	Instantaneous flow rate	5	Per hour **	b2	Instantaneous flow rate	5	Per minute **	c	Total flow	7	Resettable to 0	d	Divided value*	1	0 (1/1), 1 (1/10), 2 (1/100)	F	Meter coefficient*	5	0.0001 to 1.9999	A	Number of cycle samples	3	1 to 128
	Mode	Display	Digit	Description																													
	—	Total flow	8	Not resettable to 0																													
	b1	Instantaneous flow rate	5	Per hour **																													
	b2	Instantaneous flow rate	5	Per minute **																													
	c	Total flow	7	Resettable to 0																													
	d	Divided value*	1	0 (1/1), 1 (1/10), 2 (1/100)																													
	F	Meter coefficient*	5	0.0001 to 1.9999																													
	A	Number of cycle samples	3	1 to 128																													
*: Not displayed when "SELECT" switch is turned to "0" or "8". When "SELECT" switch is turned to "4" or "c", the values of the above 7 items are displayed. The setting of "Divided value", "Meter coefficient", and "Number of cycle samples" can be changed easily by the operation on the front panel of this instrument. However, do not change them except when the change is unavoidable, because the setting has been adjusted to meet the specifications of the flowmeter combined to this instrument.																																	
** : Effectively indicated only when the input pulse has small frequency variation.																																	
Weak battery voltage alarm	"BATT" blinks.																																
Input signal Trigger level	3V DC hysteresis 0.8V DC																																
Input signal Response pulse	200Hz (50Hz in the case of contact input).....Standard Note that it can be followed up to 2kHz by setting the input division to 1/10 or 1/100. When the scaler value is more than 1, 150Hz max.																																
Power supply for the oscillator	13.5V DC or 24V DC, 50mA, with overcurrent protection																																
Output signal	Pulse	Types of signals	Open collector pulse, Corrective pulse (the same unit as the display), Standard...or non-corrective pulse																														
		Capacity	30V DC, 50mA max.																														
		ON-state voltage	1.5V DC max.																														
		Pulse width	1ms, 50ms, 100ms, 250ms																														
	Analog (option)	Signal	4 to 20mA DC and 1 to 5V DC																														
		Load resistance	Current output: 350Ω max. When output voltage is short-circuited: 600Ω max. Output voltage: 1MΩ min.																														
		Conversion accuracy	Within ±0.1% of the full scale																														
		Ripple	Within 1% of the full scale at 10% of the full scale																														
	Upper/lower limit alarm (option)	Time constant	Full scale puls	4(2) to 19.99Hz: 6.5s [The value in () shows the value when an internal step-up circuit is used.] 20 to 199.9Hz: 2.1s 200 to 2000Hz: 1.5s																													
		Output signal	Open MOS-FET × 2																														
Capacity		230 V AC/340 V DC, 200 mA or less																															
Upper/lower limit alarm (option)	ON resistance	16 Ω or less (leakage current 1 μA or less when OFF)																															
Setting Scaler	0.0001 to 1.9999, Adjustable in steps of 0.0001																																
Setting Dividing	Selection of the unit to be displayed: 1/1, 1/10, or 1/100																																
Backup function	The counter display value and setting are backed up by built-in E ² PROM																																
Ambient temperature	-10 to +50 C																																
Power voltage	85 to 264V AC, 50/60Hz																																
Power consumption	16VA max.																																
Insulation resistance	Batch power terminals and ground terminal, 10MΩ or more, 500V DC megger																																
Withstand voltage	Batch power terminals and ground terminal, 1500V AC, 1 minute																																
Mass	Approx. 0.6kg (flush mount type), approx. 0.8kg (wall type)																																
Case	Resin frame and aluminum case (flush mount type), plastic case (wall type)																																
Finish color of the instrument frame	Munsell color code N1.5 equivalent																																

CODE SYMBOLS

Digit	Description	FMM	Digit ←												
			4	5	6	7	8	9	10						
4	<Power voltage> 85 to 264V AC 50/60Hz							3							
5	Input signal 3-wire open corrector pulse				6										
6	Output signal (open collector) Pulse width: Approx. 1ms Pulse width: Approx. 50ms Pulse Width: Approx. 100ms Pulse width: Approx. 250ms					2	5	6	7						
7	<Analog output and alarm output signal> None (Standard) Analog output (4 to 20mA DC / 1 to 5V DC) and upper/lower limit alarm output							0	1						
8	<Modification No.>									3					
9	Additional function None (Standard) With a battery for lighting the LCD when power is OFF											0	1		
10	<Construction> Flush mount type Wall type													1	2

OUTLINE DIAGRAM (Unit: mm)

(Flush mount type)

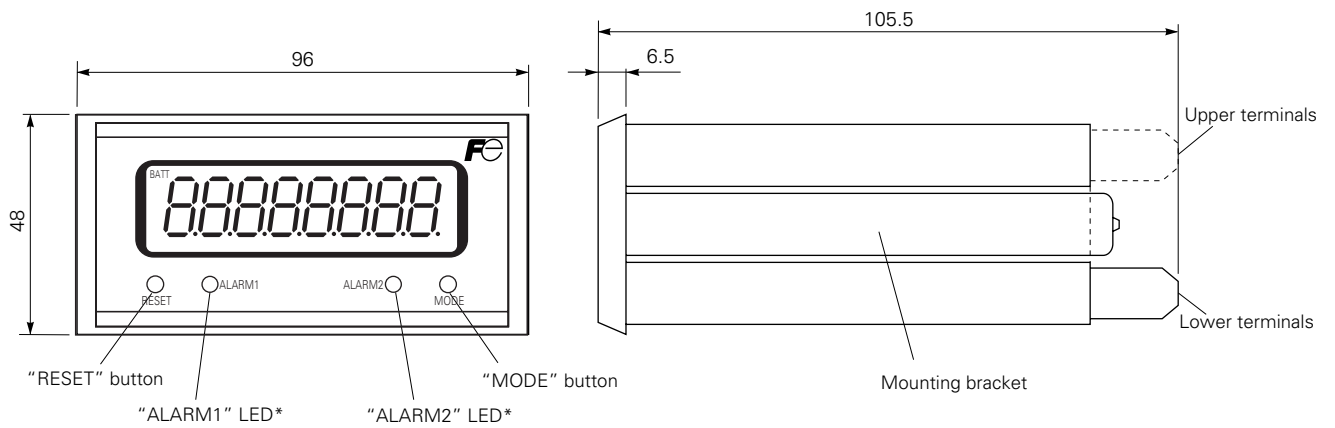

* Only for analog/alarm output (Code symbol 7th digit: "1")

PANEL CUTOUT DIMENSIONS

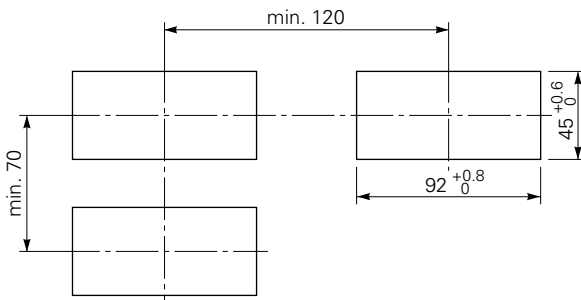

OUTLINE DIAGRAM (Unit: mm)

(Wall type)

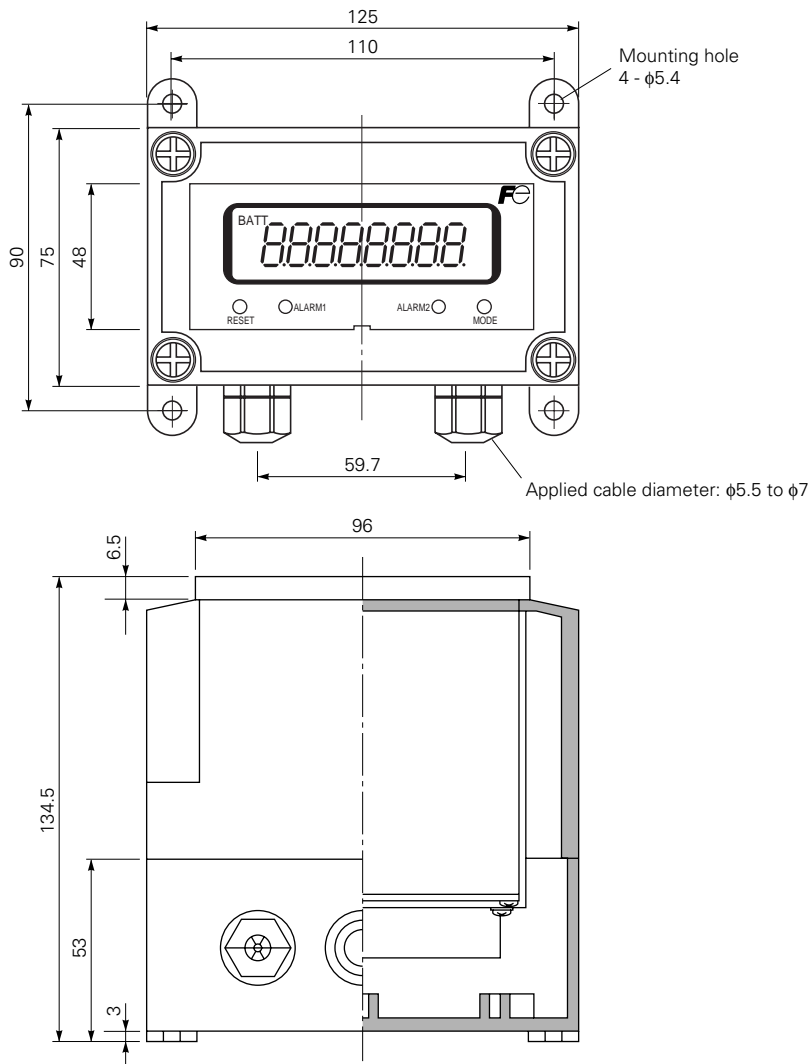

CONNECTIONS

Category	Terminal No.	Display	Description
Lower terminals	1	SUP.	FLOW INPUT Flow rate input ← 3-wire pulse input
	2	SIG.	
	3	0V	
	4	+	PULSE OUT Pulse output ← Open collector output
	5	-	
	6	L1 (+)	POWER Power ← AC power
	7	L2 (-)	
	8		Grounding Grounded (Earth)
Upper terminals	1	+	ANALOG OUT Current output ← 4 to 20mA DC <option>
	2	-	
	3	+	Voltage output ← 1 to 5V DC <option>
	4	-	
	5	ALARM1 OUT	Alarm output ← Open MOS-FET <option> (non polar)
	6	OUT	
	7	ALARM2 OUT	Alarm output ← Open MOS-FET <option> (non polar)
	8	OUT	

Terminal connecting screw: M3.5

WHEN PLACING AN ORDER, SPECIFY:

1. Integrating meter type
2. Type of combined flowmeter
3. Unit of integration and output pulse
4. Kind of output signal
 Correct pulse / Non-correct pulse
5. Source voltage
6. Installation site conditions, etc.

For enquiry, show us the following specifications.

Fill out the required portions or make check marks in the squares.

Setting item	Specification
1. Measured fluid	
2. Range of flow rate	Max. _____ Usual _____ Min. _____ L/min (actual)* ¹ * Analog full scale corresponds to maximum value.
3. Temperature range	Max. _____ Usual _____ Min. _____ °C
4. Pressure range	Max. _____ Usual _____ Min. _____ MPa [gauge]
5. Gravity or density	Gravity _____ <input type="checkbox"/> kg/m ³ [normal] <input type="checkbox"/> kg/m ³ [actual] Density _____
6. Viscosity* ²	_____ <input type="checkbox"/> mPa·s (cP) <input type="checkbox"/> mm ² /s at _____ °C
7. Pulse signal	<input type="checkbox"/> Non-correct pulse, <input type="checkbox"/> Correct pulse
8. Special comment	

*1: Instead of standard unit L/min (actual), you can use a combination of an item each in (1), (2), and (3).
If the maximum flow rate exceeds 50000 L/h (normal), the combination must include m³ and (normal).

(1) kL m³ g kg

(2) /h /min

(3) normal (for kL or m³) actual

If "normal" was selected in (3), specify reference temperature and reference pressure.

Reference temperature _____ °C Reference pressure _____ MPa [gauge]

*2: Depending on the viscosity, the measurement could be impossible [3 mPa·s (cP) or less is recommended].

⚠ Caution on Safety

*Before using this product, be sure to read its instruction manual in advance.

Fuji Electric Systems Co., Ltd.

Head Office

Gate City Ohsaki, East Tower, 11-2, Osaki 1-chome,
Shinagawa-ku, Tokyo 141-0032, Japan

<http://www.fesys.co.jp/eng>

Instrumentation Div.

International Sales Dept.

No.1, Fuji-machi, Hino-city, Tokyo, 191-8502 Japan

Phone: 81-42-585-6201, 6202 Fax: 81-42-585-6187

<http://www.fic-net.jp/eng>

Information in this catalog is subject to change without notice.

Printed in Japan