

## 600-067 Tie-Dex II® Pneumatic Standard Banding Tool

**The 600-067 Tie-Dex II® Standard Banding Tool** accommodates standard 600-052 and 600-090 bands (see page 36) in a tension range of from 100-180 lbs. Calibrate at 150 lbs. ± 5 lbs for most shield terminations. Weight of the tool is 2.52 lbs (1.14 Kg); the control box weighs 2.74 lbs (1.24 Kg).

Reference: **BAND-IT®** part number A35199.

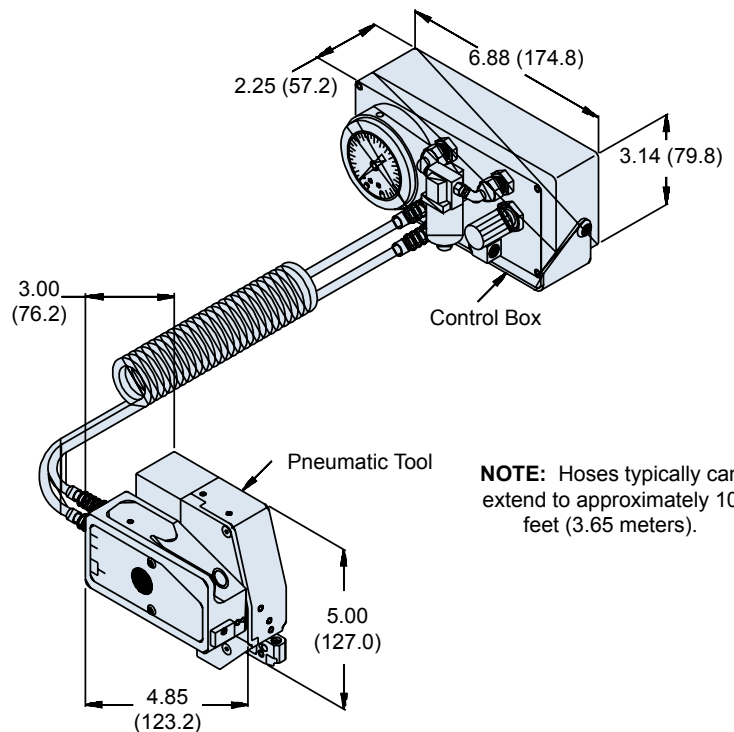

## 600-068 Tie-Dex II® Pneumatic Micro Banding Tool

**The 600-068 Tie-Dex II® Pneumatic Micro Banding Tool** accommodates 600-057 and 600-083 Micro Bands (see page 36) in a tension range of from 50 to 80 lbs. Calibrate at 75 lbs. +2 lbs. -7 lbs. for most shield terminations. Weight of the tool is 2.52 lbs (1.14 Kg); the control box weighs 2.74 lbs (1.24 Kg).

Reference: **BAND-IT®** part number A35599.

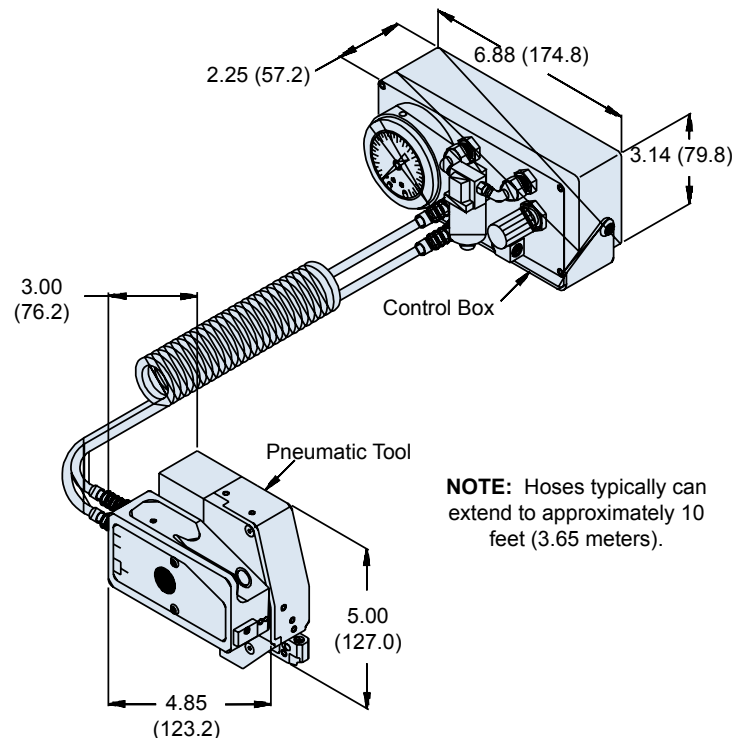

Metric Dimensions (mm) are indicated in parentheses.