

4 TERMINAL LOW DROP VOLTAGE REGULATOR

The KIA78MR × × series are Low Drop Voltage Regulator suitable for various electronic equipments. It provides constant voltage power source with TO-220 4 terminal lead full molded PKG.

The Regulator has multi function such as over current protection, overheat protection and ON/OFF control.

FEATURES

- 0.5A Output Low Drop Voltage Regulator.
- Built in ON/OFF Control Terminal.
- Built in Over Current Protection, Over Heat Protection Function.

LINE UP

ITEM	OUTPUT VOLTAGE (Typ.)	UNIT
* KIA78MR18PI	1.8	V
* KIA78MR25PI	2.5	
* KIA78MR30PI	3.0	
* KIA78MR33PI	3.3	
* KIA78MR35PI	3.5	
* KIA78MR37PI	3.7	

Note) * : Under development

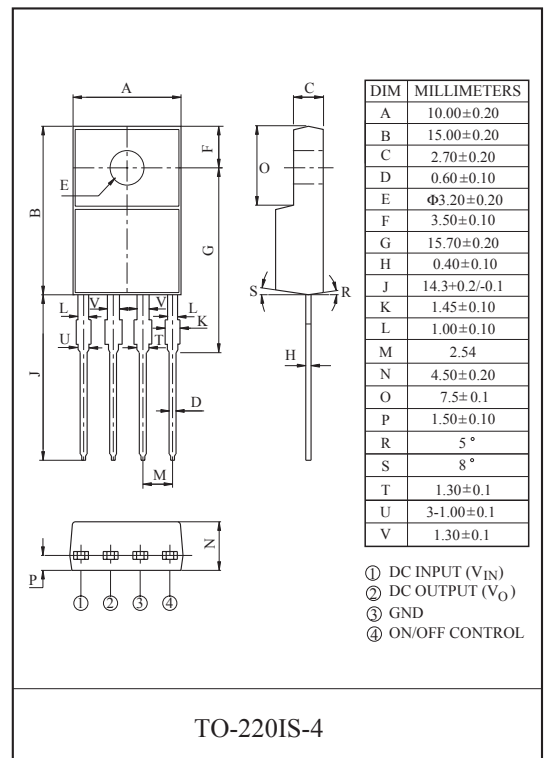

MAXIMUM RATING (Ta=25°C)

CHARACTERISTIC	SYMBOL	RATING	UNIT	Remark
Input Voltage	V _{IN}	35	V	-
ON/OFF Control Voltage	V _C	35	V	-
Output Current	I _O	0.5	A	-
Power Dissipation 1	P _{d1}	1.5	W	No heatsink
Power Dissipation 2	P _{d2}	15	W	with heatsink
Junction Temperature	T _j	125	°C	-
Operating Temperature	T _{opr}	-20 ~ 80	°C	-
Storage Temperature	T _{stg}	-30 ~ 125	°C	-
Soldering Temperature (10sec)	T _{sol}	260	°C	-

KIA78MR18PI~KIA78MR37PI

ELECTRICAL CHARACTERISTICS

(Unless otherwise specified, $I_O=0.25A$, $T_a=25^\circ C$, Note1.)

CHARACTERISTIC		SYMBOL	CONDITIONS	MIN.	TYP.	MAX.	UNIT
Output Voltage	KIA78MR18	V_O	-	1.764	1.80	1.836	V
	KIA78MR25		-	2.438	2.50	2.562	
	KIA78MR30		-	2.925	3.00	3.075	
	KIA78MR33		-	3.220	3.30	3.380	
	KIA78MR35		-	3.413	3.50	3.587	
	KIA78MR37		-	3.608	3.70	3.792	
Load Regulation		Reg Load	$I_O=5mA \sim 0.5A$	-	0.1	2.0	%
Line Regulation		Reg Line	(Note 2)	-	0.5	2.5	%
Temperature Coefficient of Output Voltage		$T_C V_O$	$T_j=0 \sim 125^\circ C$	-	± 0.02	± 0.05	%/ $^\circ C$
Ripple Rejection		$R \cdot R$	-	55	65	-	dB
Drop Out Voltage		V_D	$I_O=0.5A$ (Note3)	-	-	0.5	V
Output ON state for control Voltage		$V_{C(ON)}$	-	2.0	-	-	V
Output ON state for control Current		$I_{C(ON)}$	$V_C=2.7V$	-	-	20	μA
Output OFF state for control Voltage		$V_{C(OFF)}$	-	-	-	0.8	V
Output OFF state for control Current		$I_{C(OFF)}$	$V_C=0.4V$	-	-	-0.4	mA
Quiescent Current		I_Q	$I_O=0$	-	-	10	mA

Note1) V_{IN} of KIA78MR18=3.5V

" KIA78MR25=4.2V

" KIA78MR30=4.7V

" KIA78MR33=5.0V

" KIA78MR35=5.2V

" KIA78MR37=5.4V

Note2) V_{IN} of KIA78MR18=2.5 ~ 10V

" KIA78MR25=3.2 ~ 10V

" KIA78MR30=3.7 ~ 10V

" KIA78MR33=4.0 ~ 10V

" KIA78MR35=4.2 ~ 10V

" KIA78MR37=4.4 ~ 10V

Note3) At $V_{IN}=0.95V_O$

BLOCK DIAGRAM

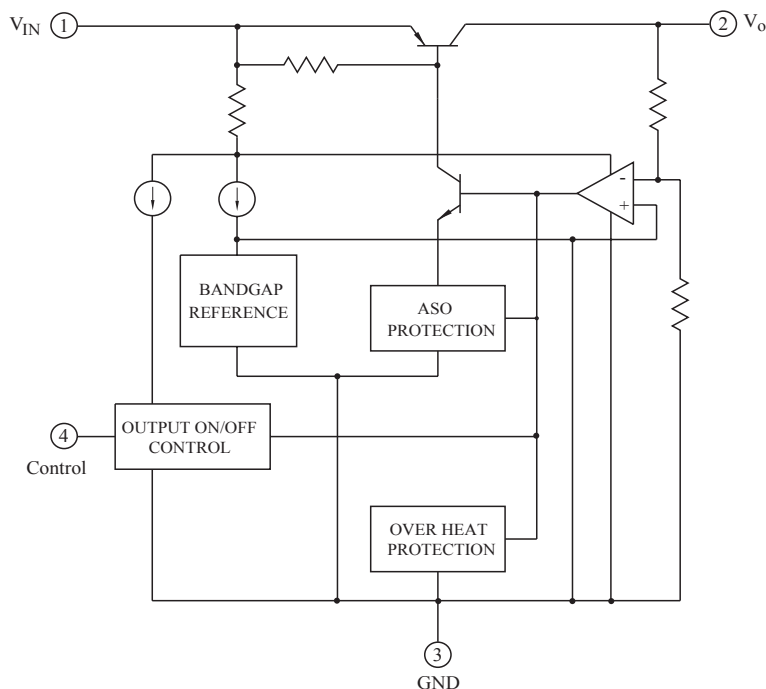

KIA78MR18PI~KIA78MR37PI

Fig. 1 Standard Test Circuit

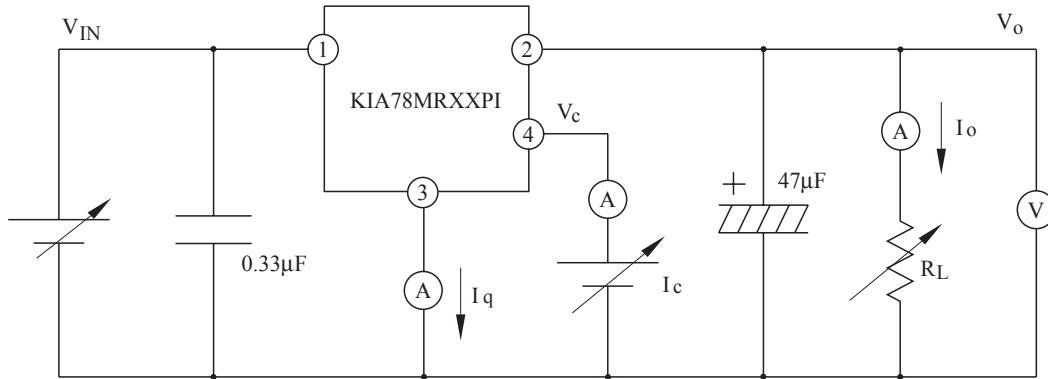

Fig. 1-2 Ripple Rejection Test Circuit

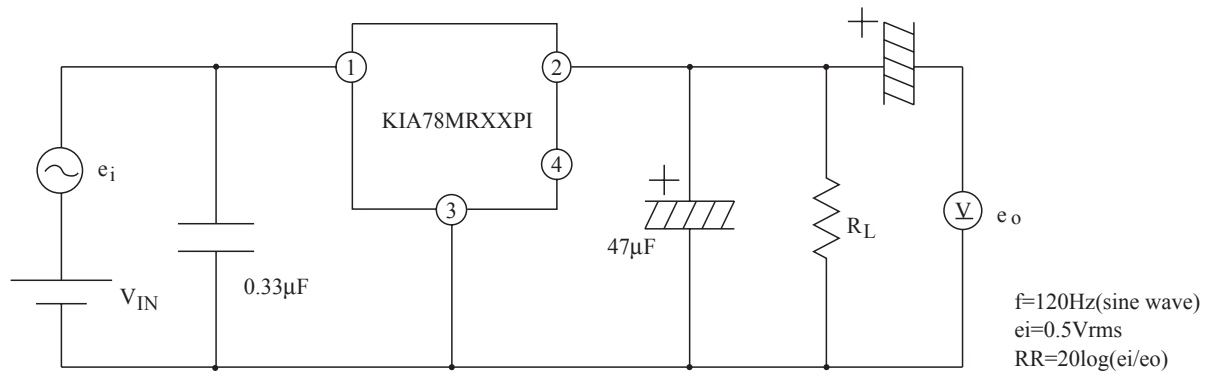
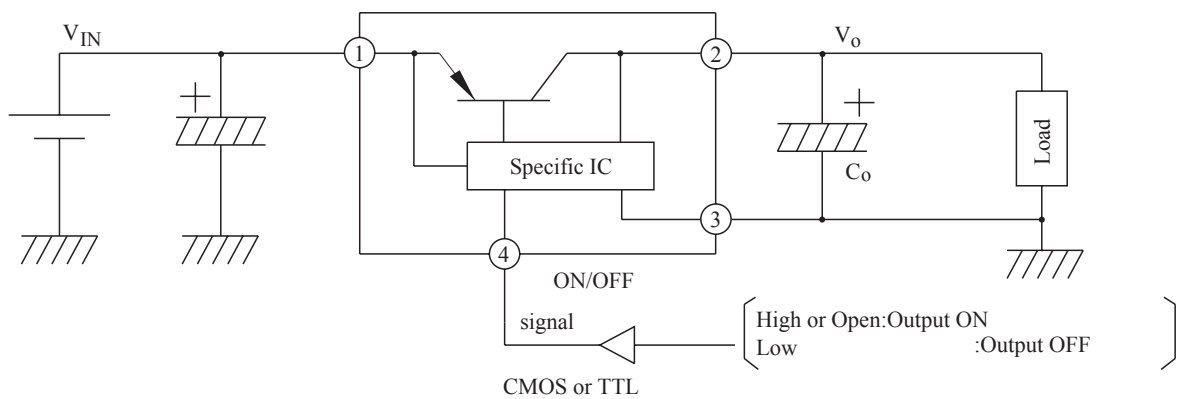
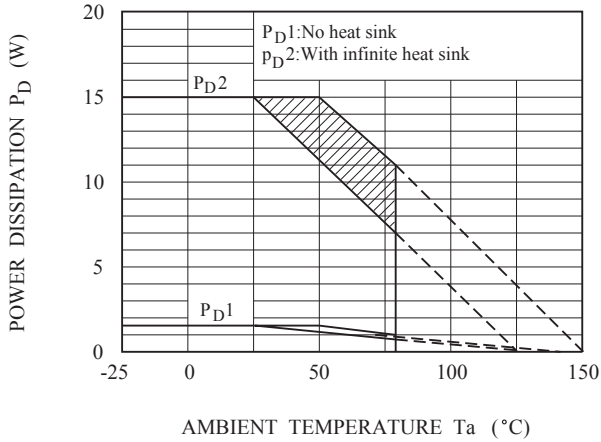

Fig. 2 Application Circuit for Standard



KIA78MR18PI~KIA78MR37PI

Fig.3 $T_a - P_D$



Note) Oblique line portion : Overheat protection may operate in this area.

Fig.4 $I_O - V_O$

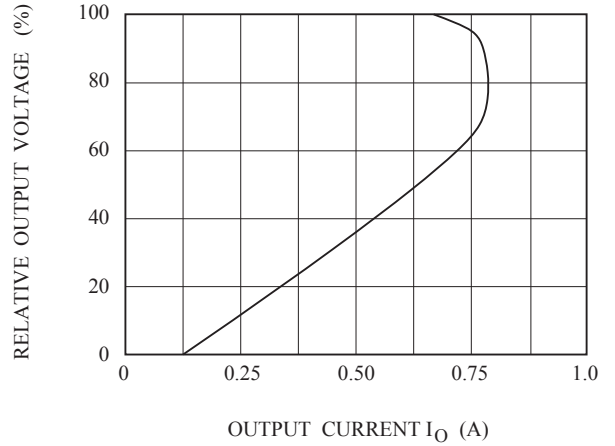

Fig.5-1 $T_j - \Delta V_O$ (KIA78MR25)

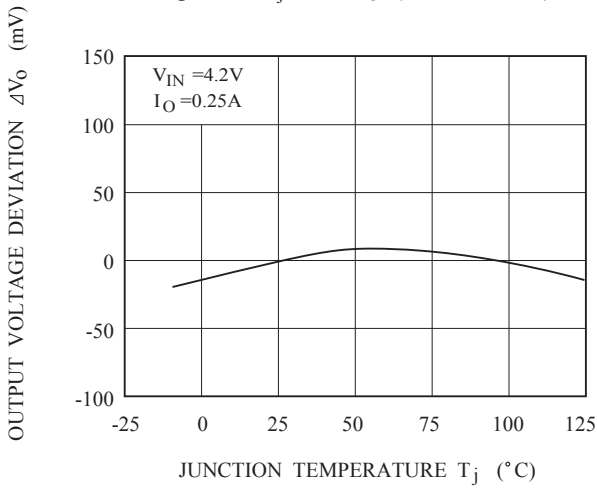

Fig.5-2 $T_j - \Delta V_O$ (KIA78MR30)

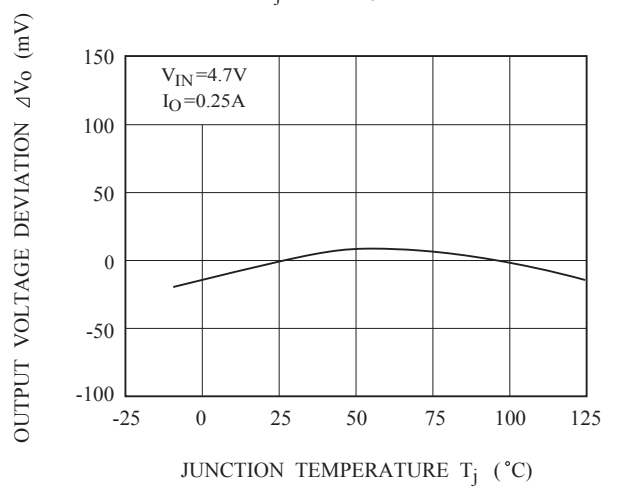

Fig.5-3 $T_j - \Delta V_O$ (KIA78MR33)

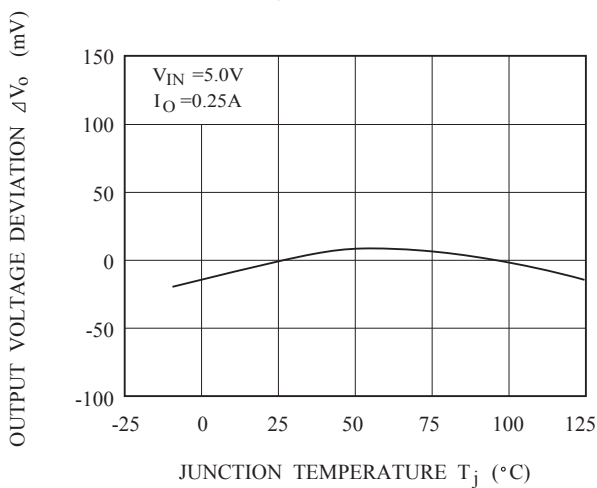
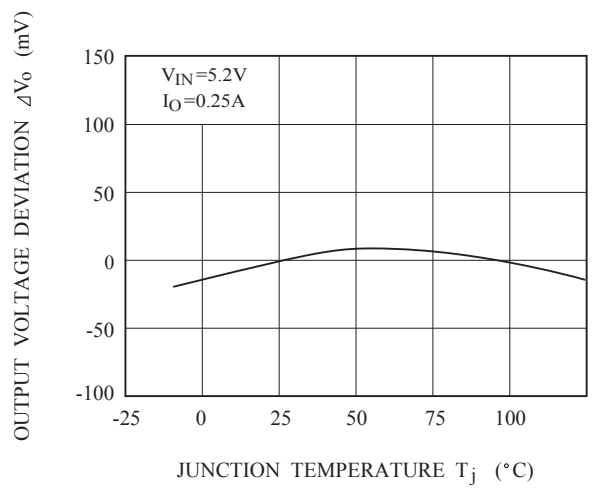

Fig.5-4 $T_j - \Delta V_O$ (KIA78MR35)



KIA78MR18PI~KIA78MR37PI

Fig.5-5 $T_j - \Delta V_o$ (KIA78MR37)

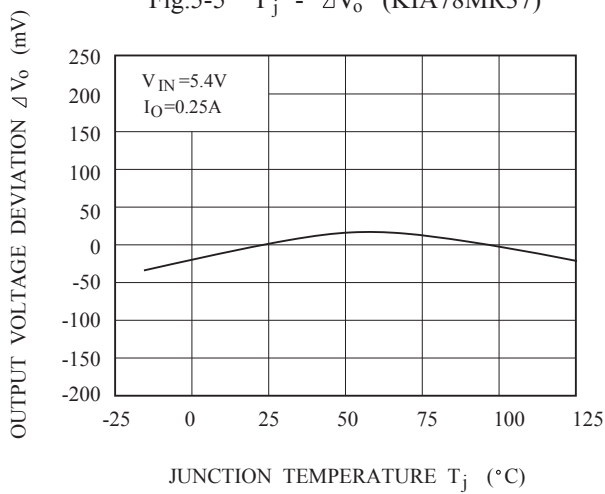

Fig.6 $T_j - V_D$

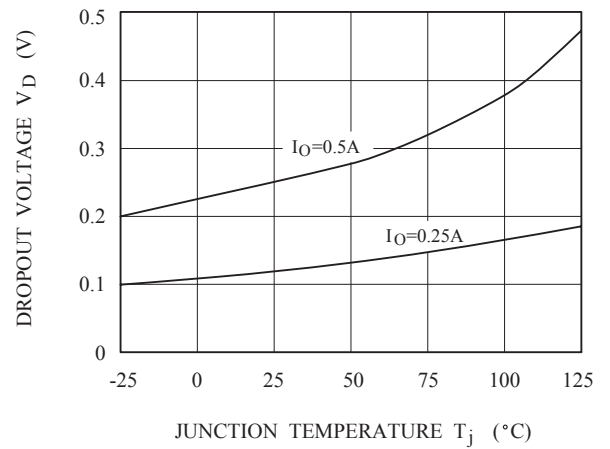

Fig.7 $T_j - I_Q$

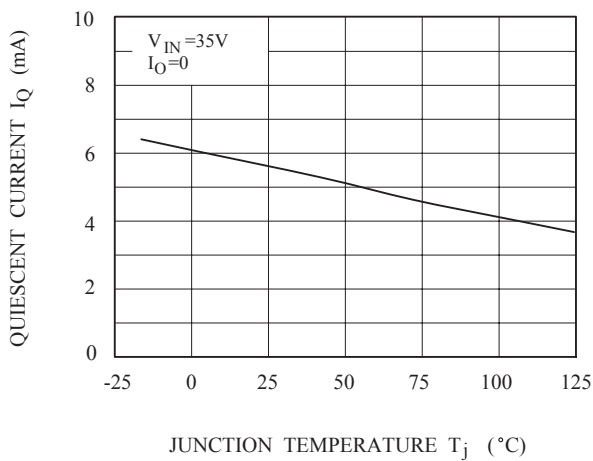

Fig.8 $f - \text{RR}$

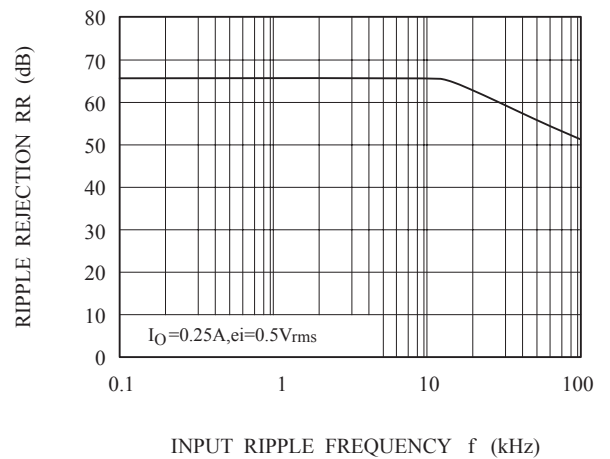

Fig.9 $I_O - \text{RR}$

