

## Silicon NPN Power Transistors

2SD1680

## DESCRIPTION

- With TO-3PFa package
- High speed switching
- High  $V_{CBO}$
- Large collector power dissipation

## APPLICATIONS

- For horizontal deflection output applications

## PINNING

PIN	DESCRIPTION
1	Base
2	Collector;connected to mounting base
3	Emitter

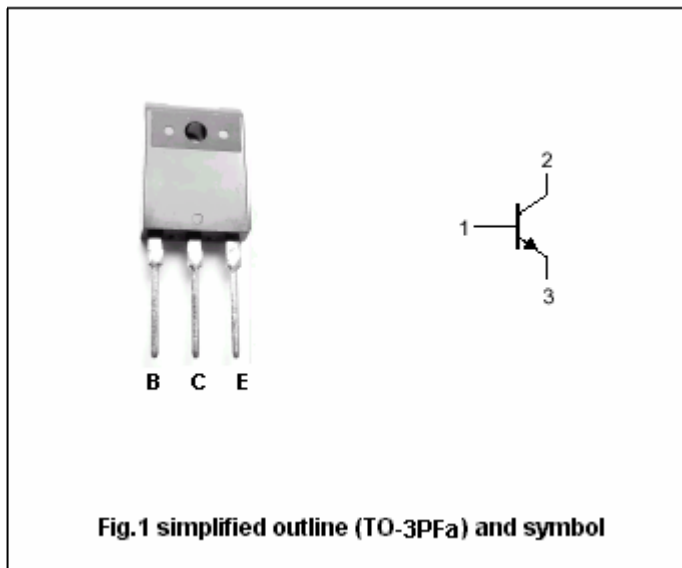
Absolute maximum ratings ( $T_a=25^\circ\text{C}$ )

SYMBOL	PARAMETER	CONDITIONS	VALUE	UNIT
$V_{CBO}$	Collector-base voltage	Open emitter	330	V
$V_{CEO}$	Collector-emitter voltage	Open base	200	V
$V_{EBO}$	Emitter-base voltage	Open collector	6	V
$I_C$	Collector current (DC)		7	A
$I_{CM}$	Collector current (Pulse)		10	A
$P_C$	Collector power dissipation	$T_a=25^\circ\text{C}$	3	W
		$T_c=25^\circ\text{C}$	70	
$T_j$	Junction temperature		150	$^\circ\text{C}$
$T_{stg}$	Storage temperature		-55~150	$^\circ\text{C}$

## Silicon NPN Power Transistors

## 2SD1680

## CHARACTERISTICS

T<sub>j</sub>=25 °C unless otherwise specified

SYMBOL	PARAMETER	CONDITIONS	MIN	TYP.	MAX	UNIT
V <sub>(BR)CEO</sub>	Collector-emitter breakdown voltage	I <sub>C</sub> =30mA ; I <sub>B</sub> =0	200			V
V <sub>(BR)CBO</sub>	Collector-base breakdown voltage	I <sub>C</sub> =1mA; I <sub>E</sub> =0	330			V
V <sub>CEsat</sub>	Collector-emitter saturation voltage	I <sub>C</sub> =5A; I <sub>B</sub> =0.5A			1.0	V
V <sub>BEsat</sub>	Base-emitter saturation voltage	I <sub>C</sub> =5A; I <sub>B</sub> =0.5A			1.2	V
I <sub>CES</sub>	Collector cut-off current	V <sub>CE</sub> =330V; V <sub>BE</sub> =0 T <sub>a</sub> =100 °C			1 15	mA
I <sub>EBO</sub>	Emitter cut-off current	V <sub>EB</sub> =6V; I <sub>C</sub> =0			1	mA
h <sub>FE</sub>	DC current gain	I <sub>C</sub> =5A ; V <sub>CE</sub> =4V	15			
t <sub>f</sub>	Fall time	I <sub>C</sub> =5A I <sub>B1</sub> =0.8A, V <sub>EB</sub> =-5V, R <sub>B</sub> =0.5Ω			0.75	μs

Silicon NPN Power Transistors

2SD1680

PACKAGE OUTLINE

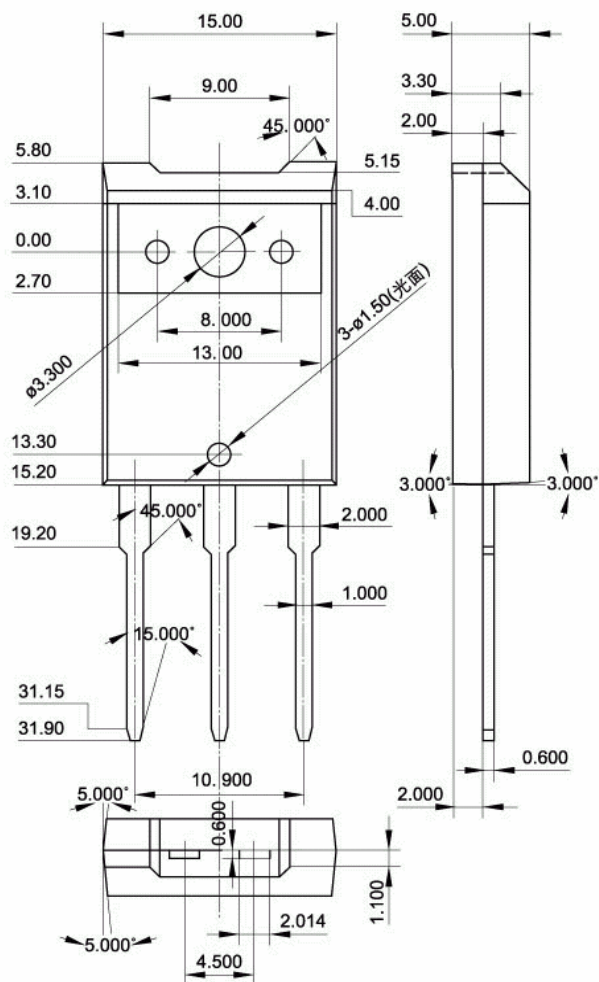

Fig.2 outline dimensions (unindicated tolerance:±0.10 mm)