

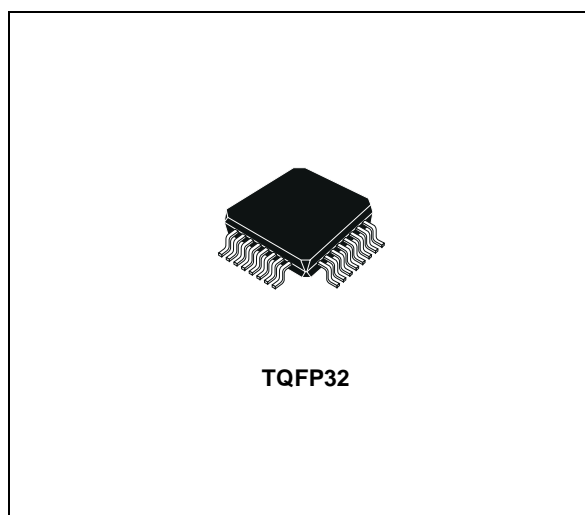

# STLVD111

## PROGRAMMABLE LOW VOLTAGE 1:10 DIFFERENTIAL LVDS CLOCK DRIVER

- 100ps PART-TO PART SKEW
- 50ps BANK SKEW
- DIFFERENTIAL DESIGN
- MEETS LVDS SPEC. FOR DRIVER OUTPUTS AND RECEIVER INPUTS
- REFERENCE VOLTAGE AVAILABLE OUTPUT  $V_{BB}$
- LOW VOLTAGE  $V_{CC}$  RANGE OF 2.375V TO 2.625V
- HIGH SIGNALLING RATE CAPABILITY (EXCEEDS 622MHz)
- SUPPORT OPEN, SHORT AND TERMINATED INPUT FAIL-SAFE (LOW OUTPUT STATE)
- PROGRAMMABLE DRIVERS POWER OFF CONTROL



### DESCRIPTION

The STLVD111 is a low skew programmable 1 to 10 differential LVDS driver, designed for clock distribution. The select signal is fanned out to 10 identical differential outputs.

The STLVD111 is provided with a 11 bit shift register with a serial in and a Control Register. The purpose is to enable or power off each output clock channel and to select the clock input. The STLVD111 is specifically designed, modelled and

produced with low skew as the key goal. Optimal design and layout serve to minimize gate to gate skew within a device. The net result is a dependable guaranteed low skew device. The STLVD111 can be used for high performance clock distribution in 2.5V systems with LVDS levels. Designers can take advantage of the device's performance to distribute low skew clocks across the backplane or the board.

### ORDERING CODES

Type	Temperature Range	Package	Comments
STLVD111BF	-40 to 85 °C	TQFP32 (Tray)	250 parts per Tray
STLVD111BFR	-40 to 85 °C	TQFP32 (Tape & Reel)	2400 parts per reel

PIN CONFIGURATION

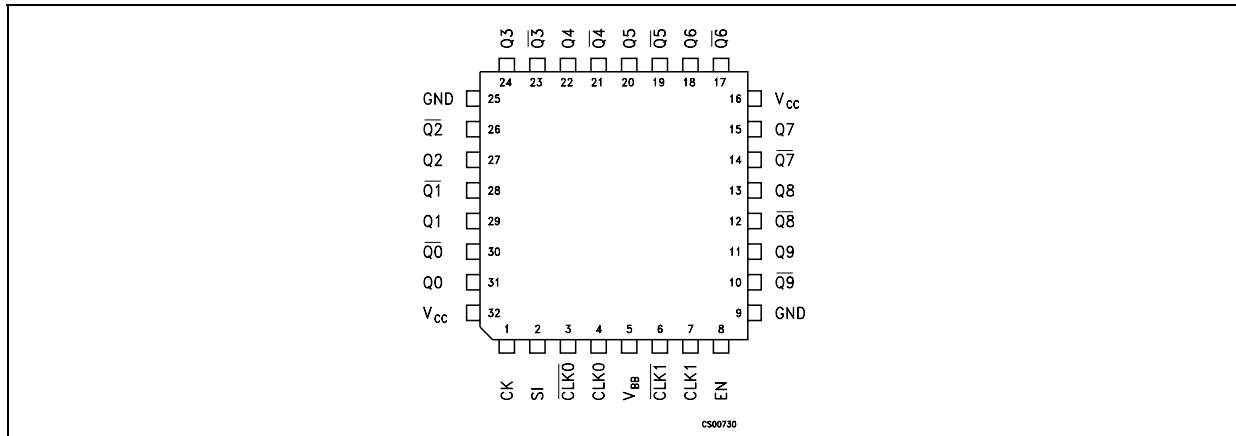

PIN DESCRIPTION

PIN N°	SYMBOL	NAME AND FUNCTION
1	CK	Control Register Clock
2	SI	Control Register Serial IN/CLK_SEL
3	CLK0	Differential Input
4	CLK0	Differential Input
5	V <sub>BB</sub>	Output Reference Voltage
6	CLK1	Differential Input
7	CLK1	Differential Input
8	EN	Device Enable/Program
9	GND	Ground
10	Q9	Differential Outputs
11	Q9	Differential Outputs
12	Q8	Differential Outputs
13	Q8	Differential Outputs
14	Q7	Differential Outputs
15	Q7	Differential Outputs
16	V <sub>CC</sub>	Supply Voltage
17	Q6	Differential Outputs
18	Q6	Differential Outputs
19	Q5	Differential Outputs
20	Q5	Differential Outputs
21	Q4	Differential Outputs
22	Q4	Differential Outputs
23	Q3	Differential Outputs
24	Q3	Differential Outputs
25	GND	Ground
26	Q2	Differential Outputs
27	Q2	Differential Outputs
28	Q1	Differential Outputs
29	Q1	Differential Outputs
30	Q0	Differential Outputs
31	Q0	Differential Outputs
32	V <sub>CC</sub>	Supply Voltage

**ABSOLUTE MAXIMUM RATINGS**

Symbol	Parameter	Value	Unit
$V_{CC}$	Supply Voltage	-0.3 to 2.8	V
$V_I$	Input Voltage	-0.2 to ( $V_{CC}+0.2$ )	V
$V_O$	Output Voltage	-0.2 to ( $V_{CC}+0.2$ )	V
$I_{OSD}$	Driver Short Circuit Current	Continuous	
ESD	Electrostatic Discharge (HBM 1.5K $\Omega$ , 100pF)	>2	KV

Absolute Maximum Ratings are those values beyond which damage to the device may occur. Functional operation under these condition is not implied.

**THERMAL DATA**

Symbol	Parameter	Value	Unit
$R_{Tj-c}$	Thermal Resistance Junction-Case	13	$^{\circ}\text{C}/\text{W}$

**RECOMMENDED OPERATING CONDITIONS**

Symbol	Parameter	Min	TYP	Max	Unit
$V_{CC}$	Supply Voltage	2.375		2.625	V
$V_{IC}$	Receiver Common Mode Input Voltage	$0.5(V_{ID})$		$2-0.5(V_{ID})$	V
$T_A$	Operating Free-Air Temperature Range	-40		85	$^{\circ}\text{C}$
$T_J$	Operating Junction Temperature	-40		105	$^{\circ}\text{C}$

**DRIVER ELECTRICAL CHARACTERISTICS** ( $T_A = -40$  to  $85^{\circ}\text{C}$ ,  $V_{CC} = 2.5\text{V} \pm 5\%$ , unless otherwise specified (Note 1, 2))

Symbol	Parameter	Test Conditions	Value			Unit
			Min.	Typ.	Max.	
$V_{OD}$	Output Differential Voltage (Fig. 2)	$R_L = 100\ \Omega$	400	500	600	mV
$\Delta V_{OD}$	$V_{OD}$ Magnitude Change				30	mV
$V_{OS}$	Offset Voltage	$-40 \leq T_A \leq 85^{\circ}\text{C}$	1.05	1.15	1.25	V
$\Delta V_{OS}$	$V_{OS}$ Magnitude Change				30	V
$I_{OS}$	Output Short Circuit Current	$V_O = 0\text{V}$		15	30	mA
		$V_{OD} = 0\text{V}$		7	15	

NOTE 1: All currents into device pins are positive; all currents out of device pins are negative. All voltages are referenced to device ground unless otherwise specified.

NOTE 2: All typical values are given for  $V_{CC} = 2.5\text{V}$  and  $T_A = 25^{\circ}\text{C}$  unless otherwise stated.

**RECEIVER ELECTRICAL CHARACTERISTICS** ( $T_A = -40$  to  $85^{\circ}\text{C}$ ,  $V_{CC} = 2.5\text{V} \pm 5\%$ , unless otherwise specified (Note 1, 2))

Symbol	Parameter	Test Conditions	Value			Unit
			Min.	Typ.	Max.	
$V_{IDH}$	Input Threshold High				100	mV
$V_{IDL}$	Input Threshold Low		-100			mV
$I_{IN}$	Input Current	$V_I = 0\text{V}$		42	100	$\mu\text{A}$
		$V_I = 0V_{CC}$		2	10	

NOTE 1: All currents into device pins are positive; all currents out of device pins are negative. All voltages are referenced to device ground unless otherwise specified.

NOTE 2: All typical values are given for  $V_{CC} = 2.5\text{V}$  and  $T_A = 25^{\circ}\text{C}$  unless otherwise stated.

**DRIVER ELECTRICAL CHARACTERISTICS** ( $T_A = -40$  to  $85$  °C,  $V_{CC} = 2.5V \pm 5\%$ , unless otherwise specified (Note 1, 2))

Symbol	Parameter	Test Conditions	Value			Unit
			Min.	Typ.	Max.	
$V_{BB}$	Output Reference Voltage	$V_{CC} = 2.5 V$	1.15	1.25	1.35	V
$I_{CCD}$	Power Supply Current	All driver enabled and loaded		125	160	mA
$C_{IN}$	Input Capacitance	$V_I = 0V$ to $V_{CC}$		5		pF
$C_{OUT}$	Output Capacitance			5		pF
$V_{IH}$	Logic Input High Threshold	$V_{CC} = 2.5 V$	2			V
$V_{IL}$	Logic Input Low Threshold	$V_{CC} = 2.5 V$			0.8	V
$I_I$	Logic Input Current	$V_{CC} = 2.5 V$ , $V_{IN} = V_{CC}$ or GND			$\pm 10$	$\mu A$

NOTE 1: All currents into device pins are positive; all currents out of device pins are negative. All voltages are referenced to device ground unless otherwise specified.

NOTE 2: All typical values are given for  $V_{CC} = 2.5V$  and  $T_A = 25^\circ C$  unless otherwise stated.

**LVDS TIMING CHARACTERISTICS** ( $T_A = -40$  to  $85$  °C,  $V_{CC} = 2.5V \pm 5\%$ , unless otherwise specified (Note 4))

Symbol	Parameter	Test Conditions	Value			Unit
			Min.	Typ.	Max.	
$t_{TLH}$ , $t_{THL}$	Transition Time	$R_L = 100 \Omega$ , $C_L = 5 pF$ , Fig. 5, 6)		220	300	ps
$t_{PHL}$ , $t_{PLH}$	Propagation Delay Time	(Fig. 5, 6)		2	2.5	ns
$f_{MAX}$	Maximum Input Frequency		700	900		MHz
$t_{SKEW}$	Bank Skew	(Fig. 1)		50		ps
	Part to Part Skew	(Fig. 2)		100		
	Pulse Skew	(Fig. 3)		50		

NOTE 4: Generator waveforms for all test conditions:  $f = 1MHz$ ,  $Z_O = 50 \Omega$  (unless otherwise specified).

**CONTROL REGISTER TIMING CHARACTERISTICS** ( $T_A = -40$  to  $85$  °C,  $V_{CC} = 2.5V \pm 5\%$ ,  $EN = H$ , unless otherwise specified (Figure 4))

Symbol	Parameter	Test Conditions	Value			Unit
			Min.	Typ.	Max.	
$f_{MAX}$	Maximum Frequency of Shift Register	(Fig. 7)	100	150		MHz
$t_s$	Clock to SI Setup Time	(Fig. 7)			2	ns
$t_h$	Clock to SI Hold Time	(Fig. 7)			1.5	ns
$t_{rem}$	Enable to Clock Removal Time	(Fig. 7)			1.5	ns
$t_w$	Minimum Clock Pulse Width	(Fig. 7)	3			ns

## SPECIFICATION OF CONTROL REGISTER

The STLVD111 is provided with a 11 bit shift register with a Serial In and a Control Register. The purpose is to enable or power of each output clock channel and to select the clock input. The STLVD111 provides two working modality:

### PROGRAMMED MODE (EN=1)

The shift register have a serial input to load the working configuration. Once the configuration is loaded with 11 clock pulse, another clock pulse load the configuration into the control register. The first bit on the serial input line enables the outputs Q9 and  $\overline{Q9}$ , the second bit enables the outputs Q8 and  $\overline{Q8}$  and so on. The last bit is the clock selection bit. To restart the configuration of the shift register a reset of the state machine must be done with a clock pulse on CK and the EN set to Low. The control register shift register can be configured on time after each reset.

### STANDARD MODE (EN=0)

In Standard Mode the STLVD111 isn't programmable, all the clock outputs are enabled. The LVDS clock input is selected from Clock 0 or Clock 1 with the SI pin as shown in the Truth Table below.

## TRUTH TABLE OF STATE MACHINE INPUTS

EN	SI	CK	OUTPUT
L	L	X	All Output Enabled, Clock 0 selected, Control Register disabled
L	H	X	All Output Enabled, Clock 1 selected, Control Register disabled
H	L	$\downarrow$	First stage stores "L", other stages store the data of previous stage
H	H	$\downarrow$	First stage stores "H", other stages store the data of previous stage
L	X	$\downarrow$	Reset of the state machine, Shift register and Control Register

## SERIAL INPUT SEQUENCE

BIT#10	BIT#9	BIT#8	BIT#7	BIT#6	BIT#5	BIT#4	BIT#3	BIT#2	BIT#1	BIT#0
CLK_SEL	Q0	Q1	Q2	Q3	Q4	Q5	Q6	Q7	Q8	Q9

## TRUTH TABLE OF THE CONTROL REGISTER

BIT#10	BIT#(0-9)	Qn(0-9)
L	H	Clock 0
H	H	Clock 1
X	L	Qn Output Disabled

## TRUTH TABLE

CK	EN	SI	CLK 0	$\overline{\text{CLK 0}}$	CLK 1	$\overline{\text{CLK 1}}$	Q (0-9)	$\overline{Q(0-9)}$
L	L	L	L	H	X	X	L	H
L	L	L	H	L	X	X	H	L
L	L	L	Open	Open	X	X	L	H
L	L	H	X	X	L	H	L	H
L	L	H	X	X	H	L	H	L
L	L	H	X	X	Open	Open	L	H
All drivers enable								

LOGIC DIAGRAM

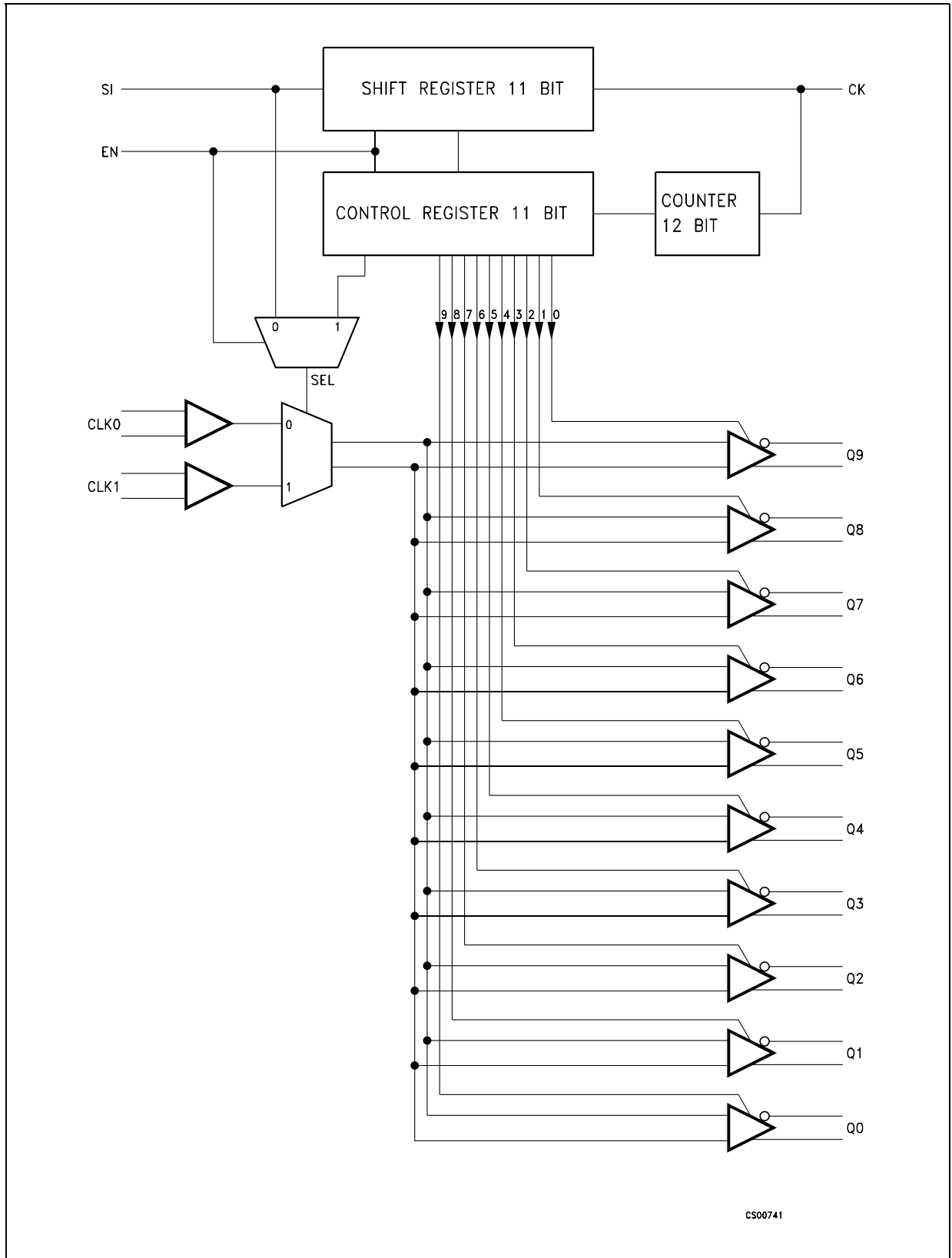

Figure 1 : BANK SKEW -  $t_{sk(b)}$

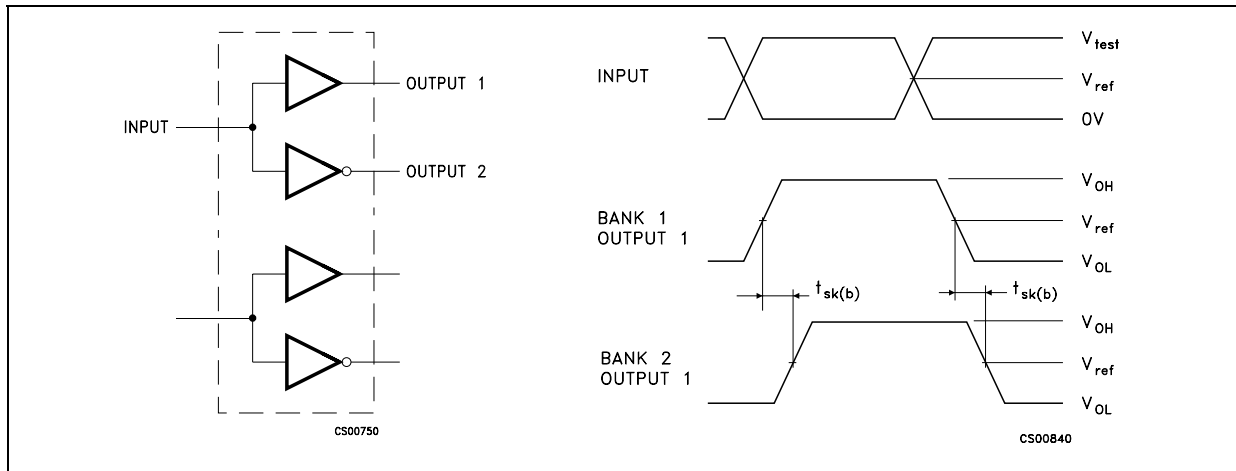

Figure 2 : PART TO PART SKEW -  $t_{sk(PP)}$

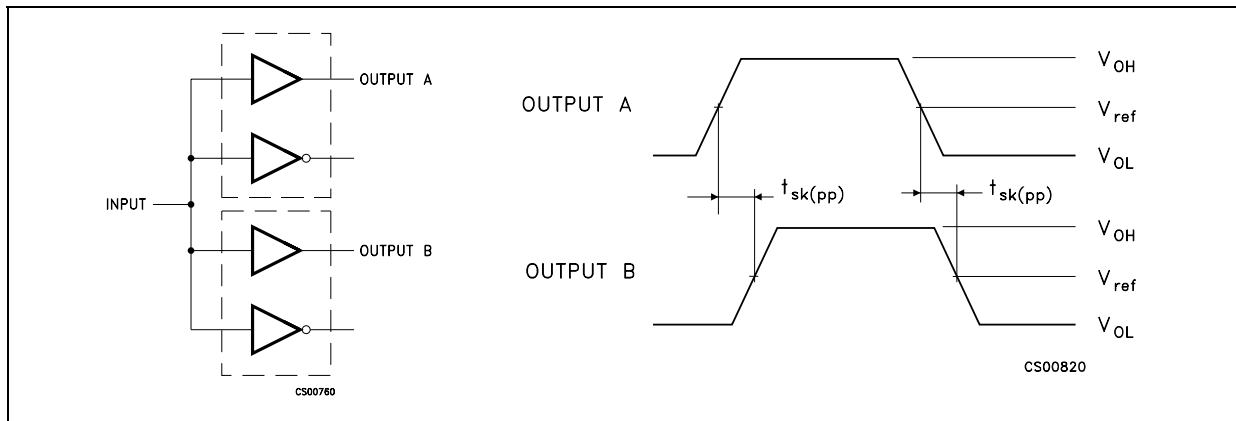
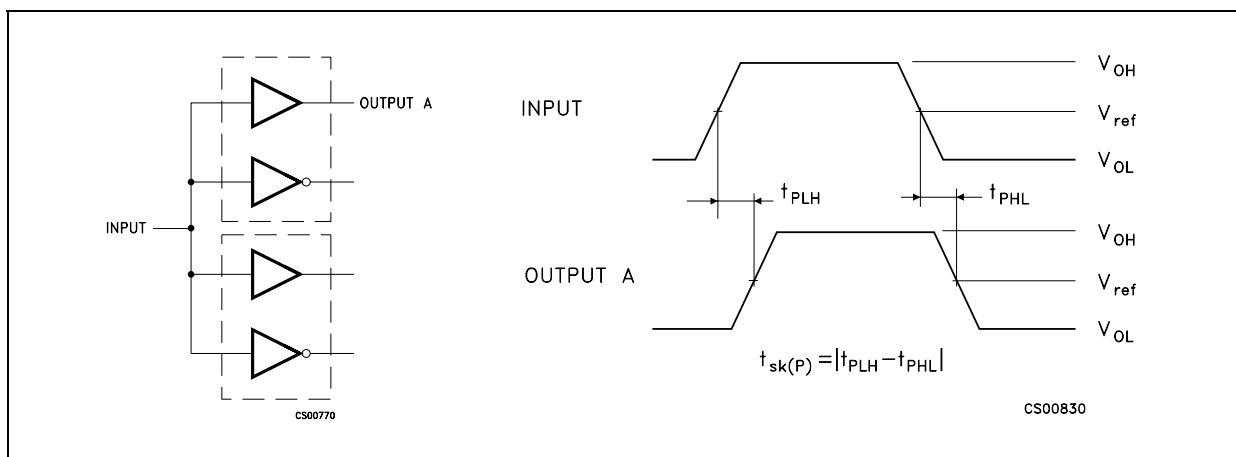

Figure 3 : PULSE SKEW -  $t_{sk(P)}$



$t_{sk(b)}$ : BANKSKEW is the magnitude of the time difference between outputs with a single driving input terminal

$t_{sk(PP)}$ : PART TO PART SKEW is the magnitude of the difference in propagation delay times between any specific terminals of two devices when both devices operate with the same input signals, the same supply voltages, and the same temperature, and have identical packages and test circuits.

$t_{sk(P)}$ : PULSE SKEW is the magnitude of the time difference between the high to low and low to high propagation delay times at an output.

Figure 4 : VOLTAGE AND CURRENT DEFINITION

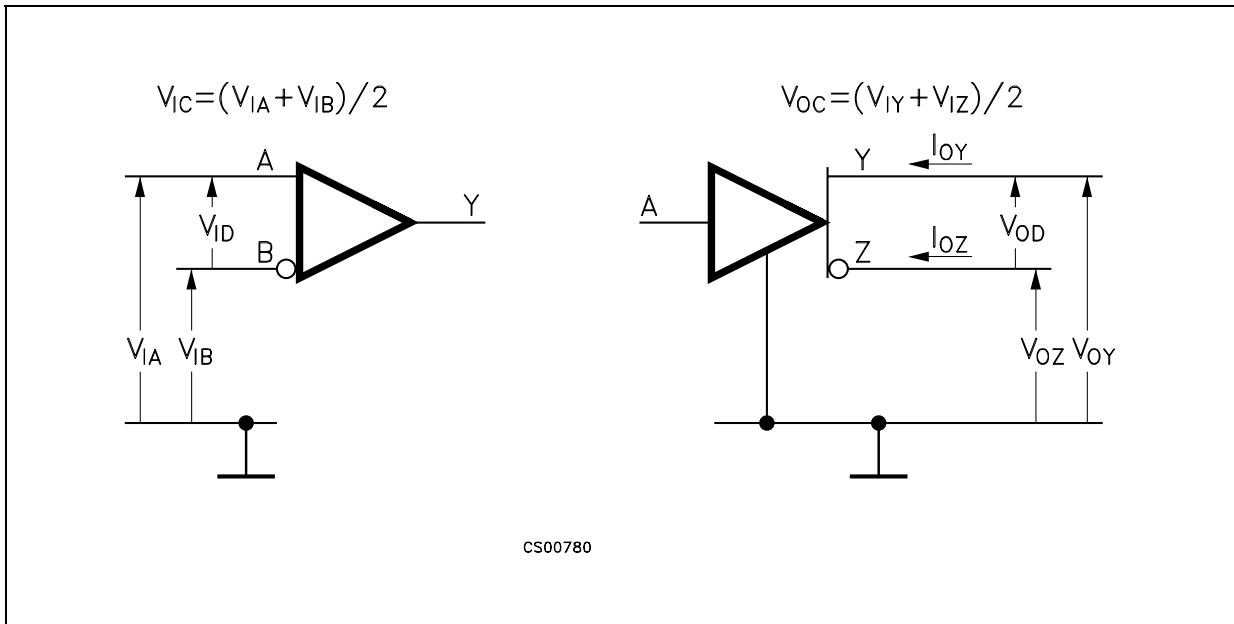
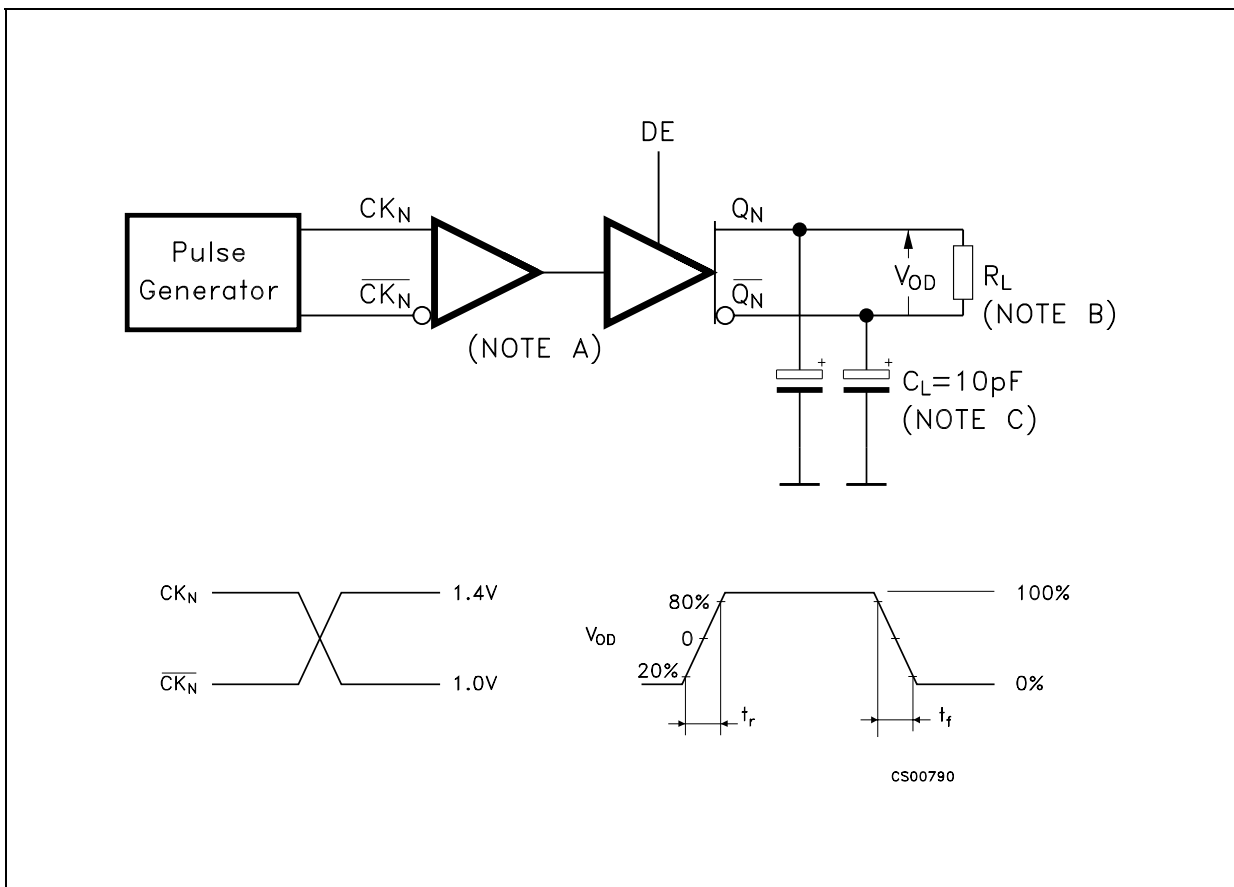
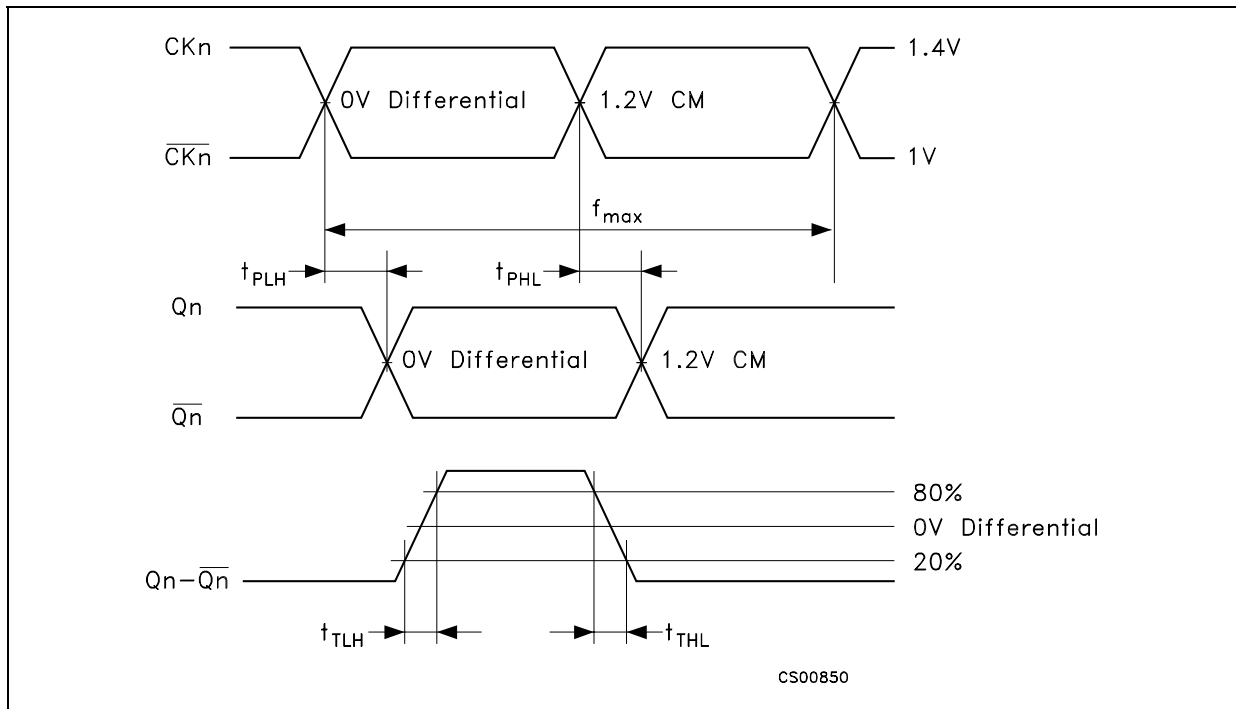

Figure 5 : TEST CIRCUIT AND VOLTAGE DEFINITION FOR THE DIFFERENTIAL OUTPUT SIGNAL

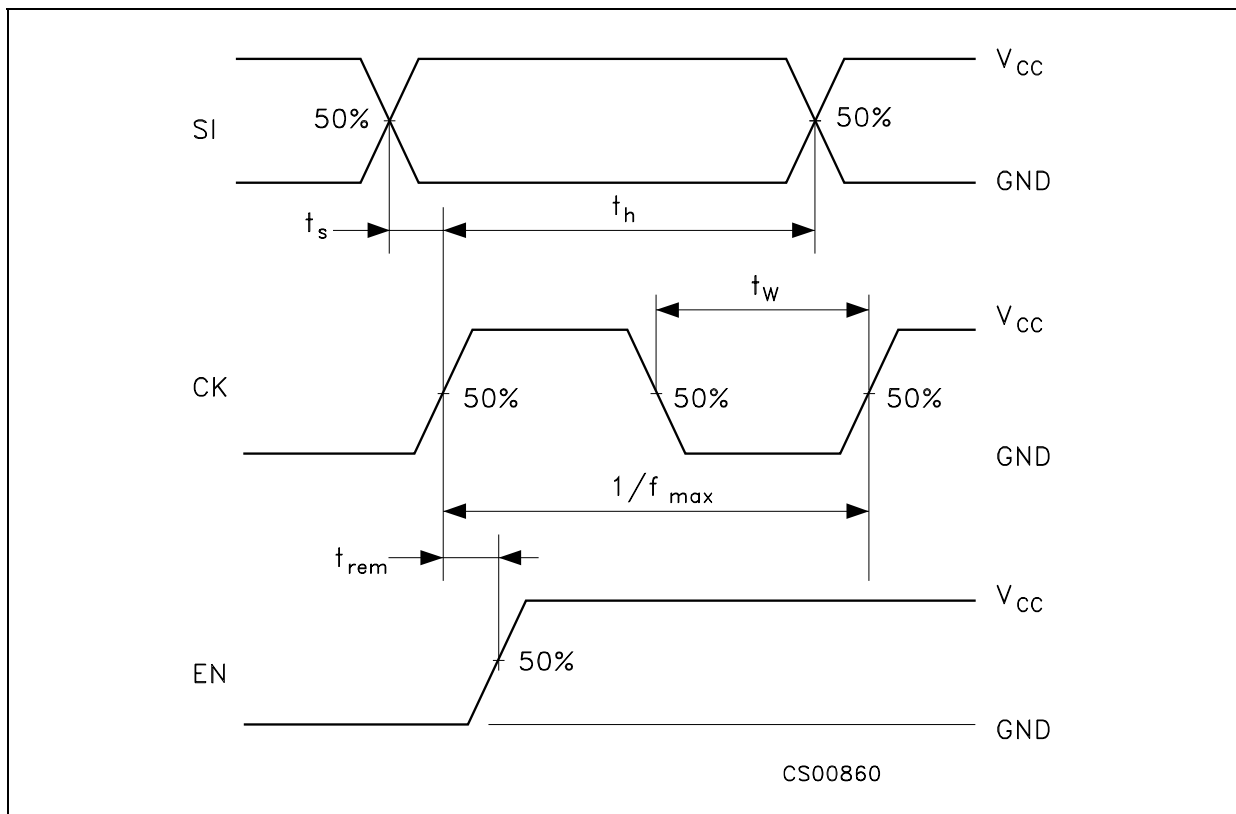



**Figure 6 : DIFFERENTIAL RECEIVER TO DRIVE PROPAGATION DELAY AND DRIVE TRANSITION TIME WAVEFORMS**

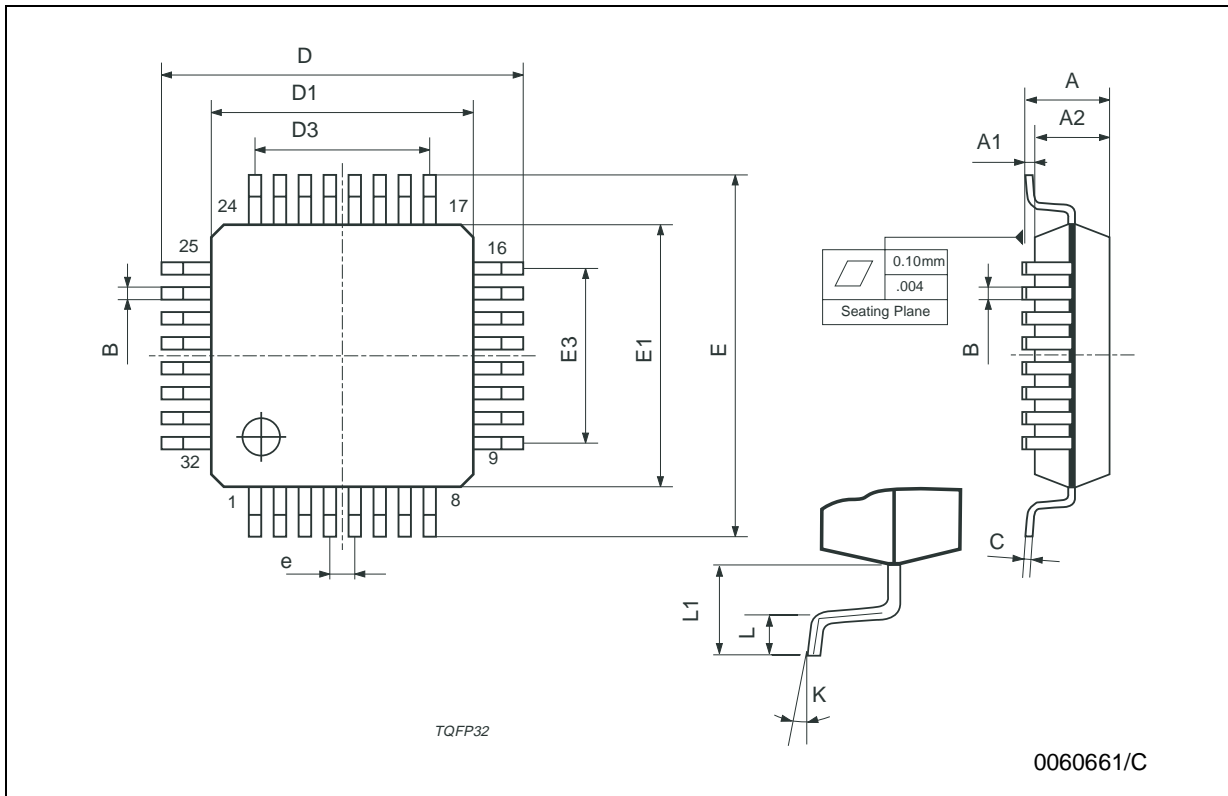

**Figure 7 : SET-UP, HOLD AND THE REMOVAL TIME, MAXIMUM FREQUENCY, MINIMUM PULSE WIDTH WAVEFORMS**



**TQFP32 MECHANICAL DATA**

DIM.	mm.			inch		
	MIN.	TYP	MAX.	MIN.	TYP.	MAX.
A			1.6			0.063
A1	0.05		0.15	0.002		0.006
A2	1.35	1.40	1.45	0.053	0.055	0.057
B	0.30	0.37	0.45	0.012	0.015	0.018
C	0.09		0.20	0.0035		0.0079
D		9.00			0.354	
D1		7.00			0.276	
D3		5.60			0.220	
E		0.80			0.031	
E		9.00			0.354	
E1		7.00			0.276	
E3		5.60			0.220	
L	0.45	0.60	0.75	0.018	0.024	0.030
L1		1.00			0.039	
K	0°	3.5°	7°	0°	3.5°	7°



## Tape &amp; Reel TQFP32 MECHANICAL DATA

DIM.	mm.			inch		
	MIN.	TYP	MAX.	MIN.	TYP.	MAX.
A			330			12.992
C	12.8		13.2	0.504		0.519
D	20.2			0.795		
N	60			2.362		
T			22.4			0.882
Ao	9.5		9.7	0.374		0.382
Bo	9.5		9.7	0.374		0.382
Ko	2.1		2.3	0.083		0.091
Po	3.9		4.1	0.153		0.161
P	11.9		12.1	0.468		0.476



Information furnished is believed to be accurate and reliable. However, STMicroelectronics assumes no responsibility for the consequences of use of such information nor for any infringement of patents or other rights of third parties which may result from its use. No license is granted by implication or otherwise under any patent or patent rights of STMicroelectronics. Specifications mentioned in this publication are subject to change without notice. This publication supersedes and replaces all information previously supplied. STMicroelectronics products are not authorized for use as critical components in life support devices or systems without express written approval of STMicroelectronics.

© The ST logo is a registered trademark of STMicroelectronics

© 2002 STMicroelectronics - Printed in Italy - All Rights Reserved  
STMicroelectronics GROUP OF COMPANIES

Australia - Brazil - Canada - China - Finland - France - Germany - Hong Kong - India - Israel - Italy - Japan - Malaysia - Malta - Morocco  
Singapore - Spain - Sweden - Switzerland - United Kingdom - United States.

© <http://www.st.com>