

# 36-Mbit (1 M × 36/2 M × 18/512 K × 72) Flow-Through SRAM with NoBL™ Architecture

## Features

- No Bus Latency™ (NoBL™) architecture eliminates dead cycles between write and read cycles
- Supports up to 133 MHz bus operations with zero wait states
  - Data is transferred on every clock
- Pin compatible and functionally equivalent to ZBT™ devices
- Internally self timed output buffer control to eliminate the need to use OE
- Registered inputs for flow through operation
- Byte write capability
- 3.3 V and 2.5 V IO power supply
- Fast clock-to-output times
  - 6.5 ns (for 133 MHz device)
- Clock Enable ( $\overline{CEN}$ ) pin to enable clock and suspend operation
- Synchronous self timed writes
- Asynchronous Output Enable
- CY7C1461AV33, CY7C1463AV33 available in JEDEC-standard Pb-free 100-pin TQFP package, Pb-free and non Pb-free 165-ball FBGA package. CY7C1465AV33 available in Pb-free and non-Pb-free 209-ball FBGA package
- Three chip enables for simple depth expansion
- Automatic power down feature available using ZZ mode or CE deselect
- IEEE 1149.1 JTAG-compatible boundary scan
- Burst capability — linear or interleaved burst order
- Low standby power

## Selection Guide

|                              | 133 MHz | 100 MHz | Unit |
|------------------------------|---------|---------|------|
| Maximum Access Time          | 6.5     | 8.5     | ns   |
| Maximum Operating Current    | 310     | 290     | mA   |
| Maximum CMOS Standby Current | 120     | 120     | mA   |

## Functional Description

The CY7C1461AV33/CY7C1463AV33/CY7C1465AV33<sup>[1]</sup> are 3.3 V, 1 M × 36/2 M × 18/512 K × 72 Synchronous Flow-Through Burst SRAMs designed specifically to support unlimited true back-to-back read and write operations without the insertion of wait states. The CY7C1461AV33/CY7C1463AV33/CY7C1465AV33 is equipped with the advanced NoBL logic required to enable consecutive read and write operations with data being transferred on every clock cycle. This feature dramatically improves the throughput of data through the SRAM, especially in systems that require frequent write-read transitions.

All synchronous inputs pass through input registers controlled by the rising edge of the clock. The clock input is qualified by the Clock Enable ( $\overline{CEN}$ ) signal, which when deasserted suspends operation and extends the previous clock cycle. Maximum access delay from the clock rise is 6.5 ns (133 MHz device).

Write operations are controlled by the two or four Byte Write Select ( $\overline{BW}_x$ ) and a Write Enable ( $\overline{WE}$ ) input. All writes are conducted with on-chip synchronous self timed write circuitry.

Three synchronous Chip Enables ( $\overline{CE}_1$ ,  $\overline{CE}_2$ ,  $\overline{CE}_3$ ) and an asynchronous Output Enable ( $\overline{OE}$ ) provide for easy bank selection and output tri-state control. To avoid bus contention, the output drivers are synchronously tri-stated during the data portion of a write sequence.

### Note

1. For best practices recommendations, refer to the Cypress application note *System Design Guidelines* on [www.cypress.com](http://www.cypress.com).

**Logic Block Diagram – CY7C1461AV33 (1 M × 36)**

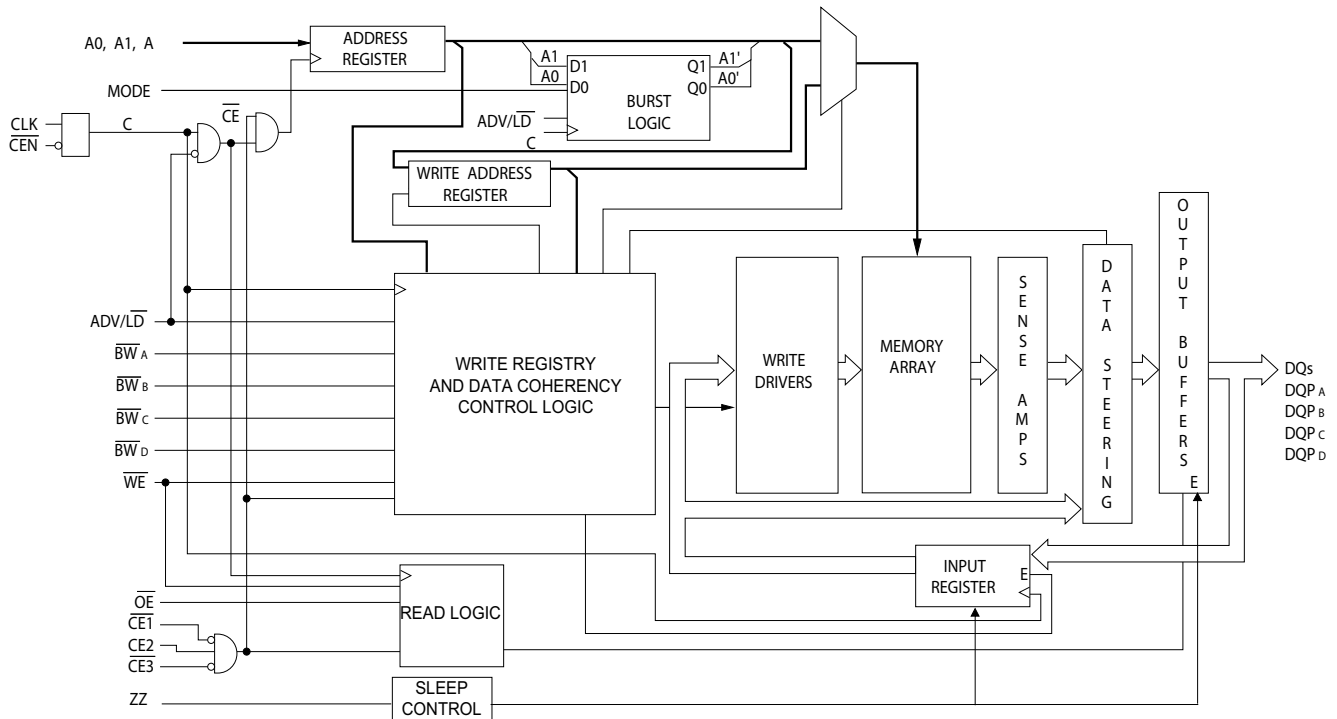

**Logic Block Diagram – CY7C1463AV33 (2 M × 18)**

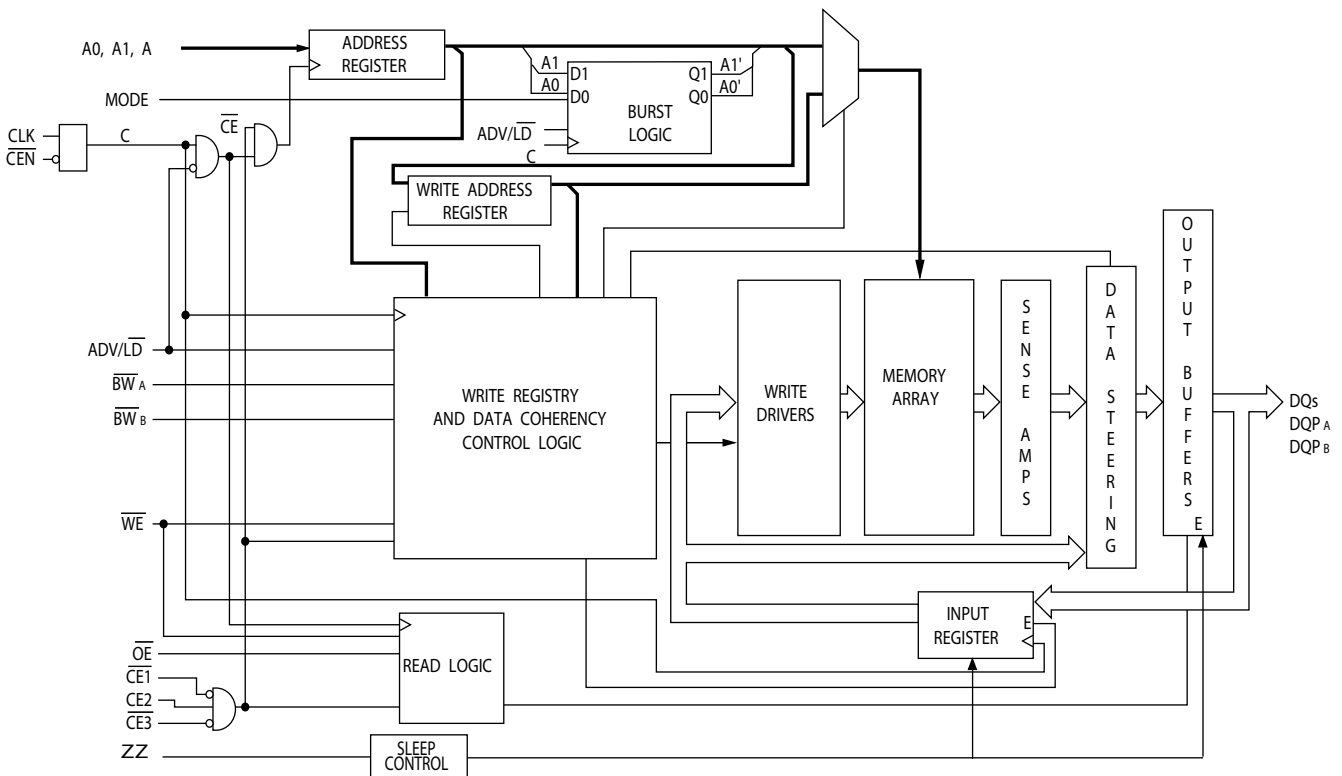

**Logic Block Diagram – CY7C1465AV33 (512 K × 72)**

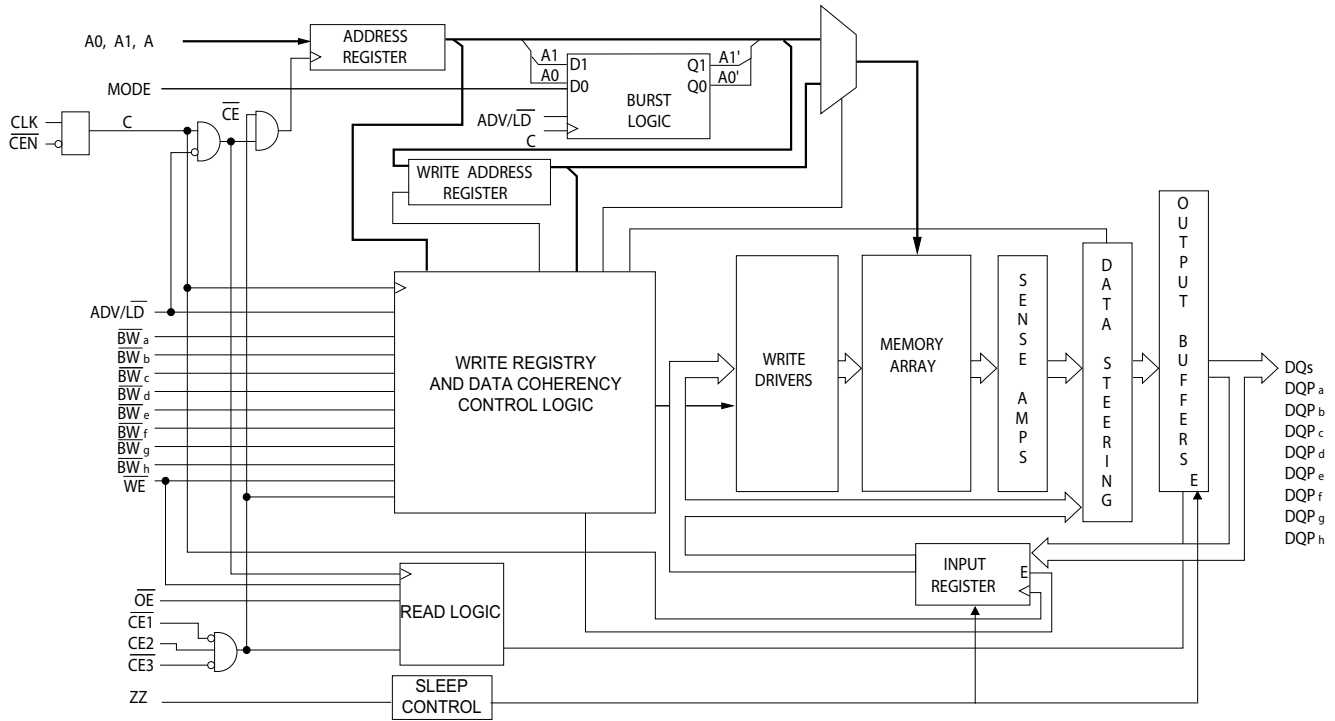

## Contents

|  |           |  |           |
|--|-----------|--|-----------|
| <b>Pin Configurations</b> .....                      | <b>5</b>  | <b>3.3 V TAP AC Test Conditions</b> .....            | <b>18</b> |
| <b>Pin Definitions</b> .....                         | <b>9</b>  | <b>3.3 V TAP AC Output Load Equivalent</b> .....     | <b>18</b> |
| <b>Functional Overview</b> .....                     | <b>10</b> | <b>2.5 V TAP AC Test Conditions</b> .....            | <b>18</b> |
| Single Read Accesses .....                           | 10        | <b>2.5 V TAP AC Output Load Equivalent</b> .....     | <b>18</b> |
| Burst Read Accesses .....                            | 10        | <b>TAP DC Electrical Characteristics and</b>         |           |
| Single Write Accesses .....                          | 11        | <b>Operating Conditions</b> .....                    | <b>18</b> |
| Burst Write Accesses .....                           | 11        | <b>Identification Register Definitions</b> .....     | <b>19</b> |
| <b>Interleaved Burst Address Table</b>               |           | <b>Scan Register Sizes</b> .....                     | <b>19</b> |
| <b>(MODE = Floating or VDD)</b> .....                | <b>11</b> | <b>Identification Codes</b> .....                    | <b>19</b> |
| <b>Linear Burst Address Table (MODE = GND)</b> ..... | <b>11</b> | <b>165-ball FBGA Boundary Scan Order</b> .....       | <b>20</b> |
| Sleep Mode .....                                     | 11        | <b>209-ball FBGA Boundary Scan Order</b> .....       | <b>21</b> |
| <b>ZZ Mode Electrical Characteristics</b> .....      | <b>11</b> | <b>Maximum Ratings</b> .....                         | <b>22</b> |
| <b>Truth Table</b> .....                             | <b>12</b> | <b>Operating Range</b> .....                         | <b>22</b> |
| <b>Truth Table for Read/Write</b> .....              | <b>13</b> | <b>Electrical Characteristics</b> .....              | <b>22</b> |
| <b>Truth Table for Read/Write</b> .....              | <b>13</b> | <b>Capacitance</b> .....                             | <b>23</b> |
| <b>Truth Table for Read/Write</b> .....              | <b>13</b> | <b>Thermal Resistance</b> .....                      | <b>23</b> |
| <b>IEEE 1149.1 Serial Boundary Scan (JTAG)</b> ..... | <b>14</b> | <b>Switching Characteristics</b> .....               | <b>24</b> |
| Disabling the JTAG Feature .....                     | 14        | <b>Switching Waveforms</b> .....                     | <b>25</b> |
| <b>TAP Controller State Diagram</b> .....            | <b>14</b> | <b>Ordering Information</b> .....                    | <b>28</b> |
| Test Access Port (TAP) .....                         | 14        | Ordering Code Definitions .....                      | 28        |
| <b>TAP Controller Block Diagram</b> .....            | <b>14</b> | <b>Package Diagrams</b> .....                        | <b>29</b> |
| PERFORMING A TAP RESET .....                         | 14        | <b>Document History Page</b> .....                   | <b>32</b> |
| TAP REGISTERS .....                                  | 14        | <b>Sales, Solutions, and Legal Information</b> ..... | <b>34</b> |
| TAP Instruction Set .....                            | 15        | Worldwide Sales and Design Support .....             | 34        |
| <b>TAP Timing</b> .....                              | <b>16</b> | Products .....                                       | 34        |
| <b>TAP AC Switching Characteristics</b> .....        | <b>17</b> | PSoC Solutions .....                                 | 34        |

### Pin Configurations

#### 100-pin TQFP Pinout

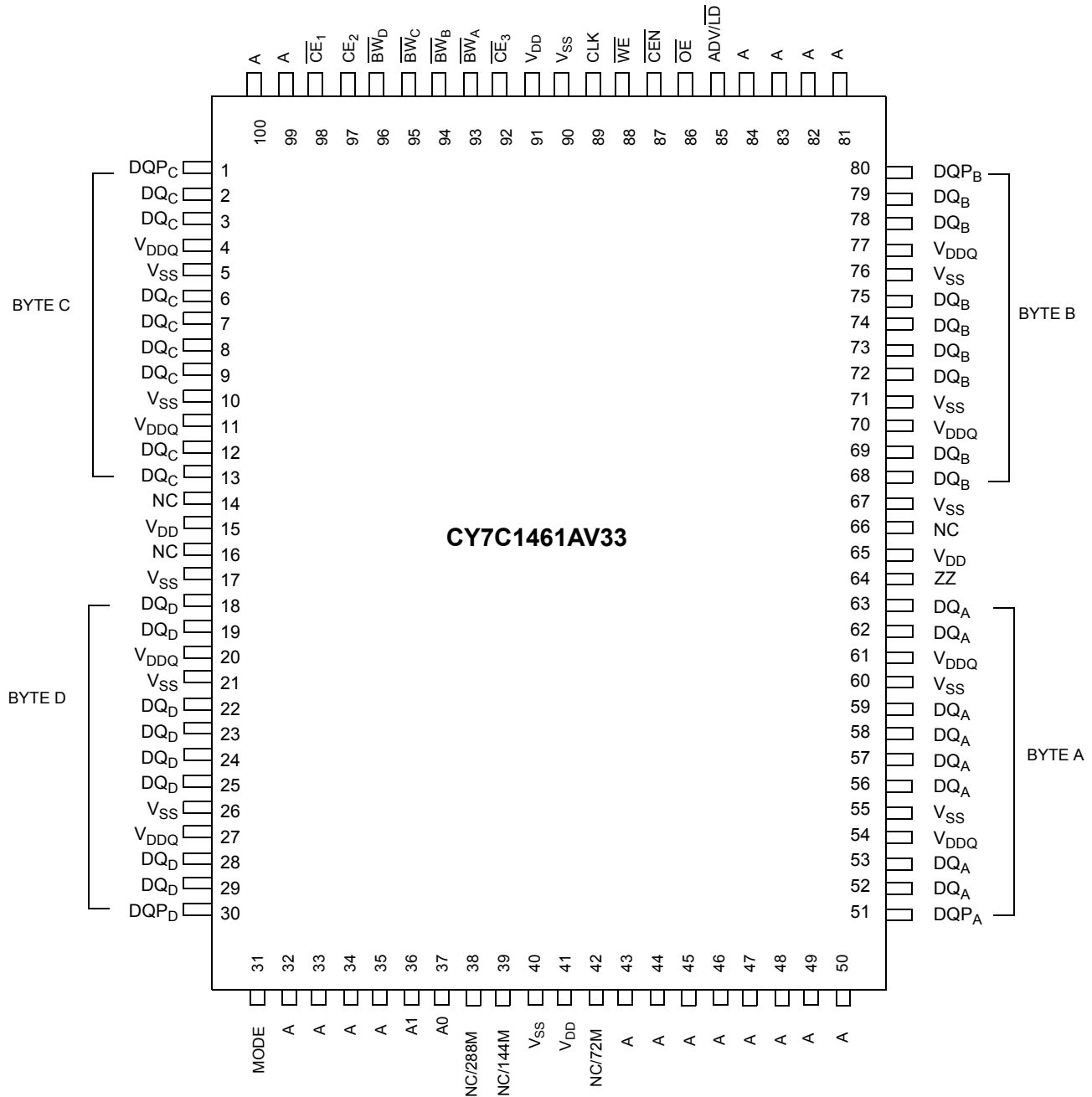

**Pin Configurations** (continued)

**100-pin TQFP Pinout**

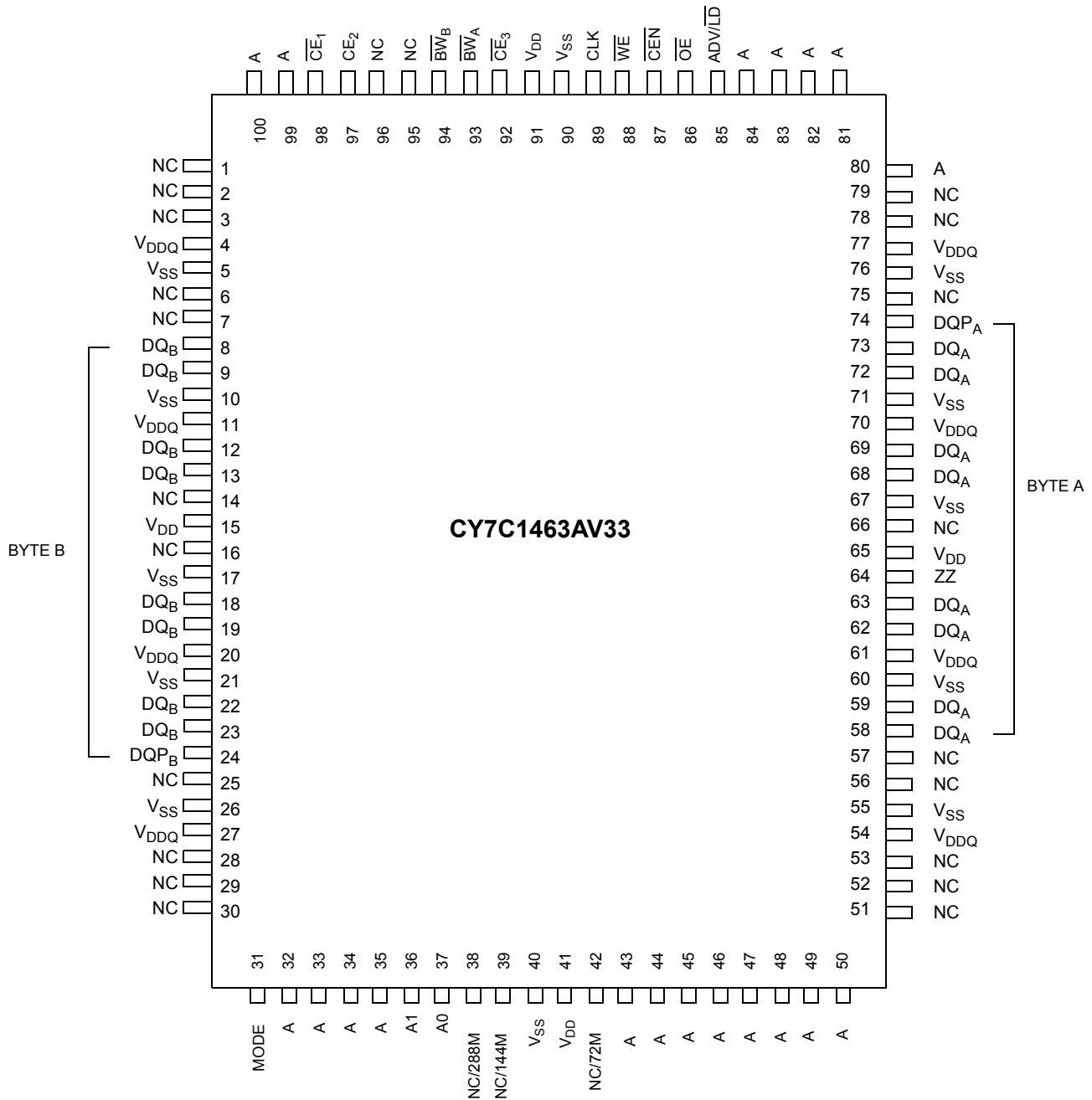

**Pin Configurations** (continued)

**165-ball FBGA (15 × 17 × 1.4 mm) Pinout**

**CY7C1461AV33 (1 M × 36)**

|          | 1                            | 2               | 3                 | 4                 | 5                 | 6                 | 7                | 8               | 9                | 10              | 11                           |
|----------|------------------------------|-----------------|-------------------|-------------------|-------------------|-------------------|------------------|-----------------|------------------|-----------------|------------------------------|
| <b>A</b> | NC/576M                      | A               | $\overline{CE}_1$ | $\overline{BW}_C$ | $\overline{BW}_B$ | $\overline{CE}_3$ | $\overline{CEN}$ | ADV/LD          | A                | A               | NC                           |
| <b>B</b> | NC/1G                        | A               | CE2               | $\overline{BW}_D$ | $\overline{BW}_A$ | CLK               | $\overline{WE}$  | $\overline{OE}$ | A                | A               | NC                           |
| <b>C</b> | DQ <sub>C</sub>              | NC              | V <sub>DDQ</sub>  | V <sub>SS</sub>   | V <sub>SS</sub>   | V <sub>SS</sub>   | V <sub>SS</sub>  | V <sub>SS</sub> | V <sub>DDQ</sub> | NC              | DQ <sub>P</sub> <sub>B</sub> |
| <b>D</b> | DQ <sub>C</sub>              | DQ <sub>C</sub> | V <sub>DDQ</sub>  | V <sub>DD</sub>   | V <sub>SS</sub>   | V <sub>SS</sub>   | V <sub>SS</sub>  | V <sub>DD</sub> | V <sub>DDQ</sub> | DQ <sub>B</sub> | DQ <sub>B</sub>              |
| <b>E</b> | DQ <sub>C</sub>              | DQ <sub>C</sub> | V <sub>DDQ</sub>  | V <sub>DD</sub>   | V <sub>SS</sub>   | V <sub>SS</sub>   | V <sub>SS</sub>  | V <sub>DD</sub> | V <sub>DDQ</sub> | DQ <sub>B</sub> | DQ <sub>B</sub>              |
| <b>F</b> | DQ <sub>C</sub>              | DQ <sub>C</sub> | V <sub>DDQ</sub>  | V <sub>DD</sub>   | V <sub>SS</sub>   | V <sub>SS</sub>   | V <sub>SS</sub>  | V <sub>DD</sub> | V <sub>DDQ</sub> | DQ <sub>B</sub> | DQ <sub>B</sub>              |
| <b>G</b> | DQ <sub>C</sub>              | DQ <sub>C</sub> | V <sub>DDQ</sub>  | V <sub>DD</sub>   | V <sub>SS</sub>   | V <sub>SS</sub>   | V <sub>SS</sub>  | V <sub>DD</sub> | V <sub>DDQ</sub> | DQ <sub>B</sub> | DQ <sub>B</sub>              |
| <b>H</b> | NC                           | NC              | NC                | V <sub>DD</sub>   | V <sub>SS</sub>   | V <sub>SS</sub>   | V <sub>SS</sub>  | V <sub>DD</sub> | NC               | NC              | ZZ                           |
| <b>J</b> | DQ <sub>D</sub>              | DQ <sub>D</sub> | V <sub>DDQ</sub>  | V <sub>DD</sub>   | V <sub>SS</sub>   | V <sub>SS</sub>   | V <sub>SS</sub>  | V <sub>DD</sub> | V <sub>DDQ</sub> | DQ <sub>A</sub> | DQ <sub>A</sub>              |
| <b>K</b> | DQ <sub>D</sub>              | DQ <sub>D</sub> | V <sub>DDQ</sub>  | V <sub>DD</sub>   | V <sub>SS</sub>   | V <sub>SS</sub>   | V <sub>SS</sub>  | V <sub>DD</sub> | V <sub>DDQ</sub> | DQ <sub>A</sub> | DQ <sub>A</sub>              |
| <b>L</b> | DQ <sub>D</sub>              | DQ <sub>D</sub> | V <sub>DDQ</sub>  | V <sub>DD</sub>   | V <sub>SS</sub>   | V <sub>SS</sub>   | V <sub>SS</sub>  | V <sub>DD</sub> | V <sub>DDQ</sub> | DQ <sub>A</sub> | DQ <sub>A</sub>              |
| <b>M</b> | DQ <sub>D</sub>              | DQ <sub>D</sub> | V <sub>DDQ</sub>  | V <sub>DD</sub>   | V <sub>SS</sub>   | V <sub>SS</sub>   | V <sub>SS</sub>  | V <sub>DD</sub> | V <sub>DDQ</sub> | DQ <sub>A</sub> | DQ <sub>A</sub>              |
| <b>N</b> | DQ <sub>P</sub> <sub>D</sub> | NC              | V <sub>DDQ</sub>  | V <sub>SS</sub>   | NC                | NC                | NC               | V <sub>SS</sub> | V <sub>DDQ</sub> | NC              | DQ <sub>P</sub> <sub>A</sub> |
| <b>P</b> | NC/144M                      | NC/72M          | A                 | A                 | TDI               | A1                | TDO              | A               | A                | A               | NC/288M                      |
| <b>R</b> | MODE                         | A               | A                 | A                 | TMS               | A0                | TCK              | A               | A                | A               | A                            |

**CY7C1463AV33 (2 M × 18)**

|          | 1                            | 2               | 3                 | 4                 | 5                 | 6                 | 7                | 8               | 9                | 10              | 11                           |
|----------|------------------------------|-----------------|-------------------|-------------------|-------------------|-------------------|------------------|-----------------|------------------|-----------------|------------------------------|
| <b>A</b> | NC/576M                      | A               | $\overline{CE}_1$ | $\overline{BW}_B$ | NC                | $\overline{CE}_3$ | $\overline{CEN}$ | ADV/LD          | A                | A               | A                            |
| <b>B</b> | NC/1G                        | A               | CE2               | NC                | $\overline{BW}_A$ | CLK               | $\overline{WE}$  | $\overline{OE}$ | A                | A               | NC                           |
| <b>C</b> | NC                           | NC              | V <sub>DDQ</sub>  | V <sub>SS</sub>   | V <sub>SS</sub>   | V <sub>SS</sub>   | V <sub>SS</sub>  | V <sub>SS</sub> | V <sub>DDQ</sub> | NC              | DQ <sub>P</sub> <sub>A</sub> |
| <b>D</b> | NC                           | DQ <sub>B</sub> | V <sub>DDQ</sub>  | V <sub>DD</sub>   | V <sub>SS</sub>   | V <sub>SS</sub>   | V <sub>SS</sub>  | V <sub>DD</sub> | V <sub>DDQ</sub> | NC              | DQ <sub>A</sub>              |
| <b>E</b> | NC                           | DQ <sub>B</sub> | V <sub>DDQ</sub>  | V <sub>DD</sub>   | V <sub>SS</sub>   | V <sub>SS</sub>   | V <sub>SS</sub>  | V <sub>DD</sub> | V <sub>DDQ</sub> | NC              | DQ <sub>A</sub>              |
| <b>F</b> | NC                           | DQ <sub>B</sub> | V <sub>DDQ</sub>  | V <sub>DD</sub>   | V <sub>SS</sub>   | V <sub>SS</sub>   | V <sub>SS</sub>  | V <sub>DD</sub> | V <sub>DDQ</sub> | NC              | DQ <sub>A</sub>              |
| <b>G</b> | NC                           | DQ <sub>B</sub> | V <sub>DDQ</sub>  | V <sub>DD</sub>   | V <sub>SS</sub>   | V <sub>SS</sub>   | V <sub>SS</sub>  | V <sub>DD</sub> | V <sub>DDQ</sub> | NC              | DQ <sub>A</sub>              |
| <b>H</b> | NC                           | NC              | NC                | V <sub>DD</sub>   | V <sub>SS</sub>   | V <sub>SS</sub>   | V <sub>SS</sub>  | V <sub>DD</sub> | NC               | NC              | ZZ                           |
| <b>J</b> | DQ <sub>B</sub>              | NC              | V <sub>DDQ</sub>  | V <sub>DD</sub>   | V <sub>SS</sub>   | V <sub>SS</sub>   | V <sub>SS</sub>  | V <sub>DD</sub> | V <sub>DDQ</sub> | DQ <sub>A</sub> | NC                           |
| <b>K</b> | DQ <sub>B</sub>              | NC              | V <sub>DDQ</sub>  | V <sub>DD</sub>   | V <sub>SS</sub>   | V <sub>SS</sub>   | V <sub>SS</sub>  | V <sub>DD</sub> | V <sub>DDQ</sub> | DQ <sub>A</sub> | NC                           |
| <b>L</b> | DQ <sub>B</sub>              | NC              | V <sub>DDQ</sub>  | V <sub>DD</sub>   | V <sub>SS</sub>   | V <sub>SS</sub>   | V <sub>SS</sub>  | V <sub>DD</sub> | V <sub>DDQ</sub> | DQ <sub>A</sub> | NC                           |
| <b>M</b> | DQ <sub>B</sub>              | NC              | V <sub>DDQ</sub>  | V <sub>DD</sub>   | V <sub>SS</sub>   | V <sub>SS</sub>   | V <sub>SS</sub>  | V <sub>DD</sub> | V <sub>DDQ</sub> | DQ <sub>A</sub> | NC                           |
| <b>N</b> | DQ <sub>P</sub> <sub>B</sub> | NC              | V <sub>DDQ</sub>  | V <sub>SS</sub>   | NC                | NC                | NC               | V <sub>SS</sub> | V <sub>DDQ</sub> | NC              | NC                           |
| <b>P</b> | NC/144M                      | NC/72M          | A                 | A                 | TDI               | A1                | TDO              | A               | A                | A               | NC/288M                      |
| <b>R</b> | MODE                         | A               | A                 | A                 | TMS               | A0                | TCK              | A               | A                | A               | A                            |

**Pin Configurations** (continued)

**209-ball FBGA (14 × 22 × 1.76 mm) Pinout**  
**CY7C1465AV33 (512 K × 72)**

|          | 1    | 2    | 3                | 4                | 5               | 6               | 7               | 8                | 9                | 10   | 11   |
|----------|------|------|------------------|------------------|-----------------|-----------------|-----------------|------------------|------------------|------|------|
| <b>A</b> | DQg  | DQg  | A                | CE <sub>2</sub>  | A               | ADV/LD          | A               | CE <sub>3</sub>  | A                | DQb  | DQb  |
| <b>B</b> | DQg  | DQg  | BWS <sub>c</sub> | BWS <sub>g</sub> | NC              | WE              | A               | BWS <sub>b</sub> | BWS <sub>f</sub> | DQb  | DQb  |
| <b>C</b> | DQg  | DQg  | BWS <sub>h</sub> | BWS <sub>d</sub> | NC/576M         | CE <sub>1</sub> | NC              | BWS <sub>e</sub> | BWS <sub>a</sub> | DQb  | DQb  |
| <b>D</b> | DQg  | DQg  | V <sub>SS</sub>  | NC               | NC/1G           | OE              | NC              | NC               | V <sub>SS</sub>  | DQb  | DQb  |
| <b>E</b> | DQPg | DQPc | V <sub>DDQ</sub> | V <sub>DDQ</sub> | V <sub>DD</sub> | V <sub>DD</sub> | V <sub>DD</sub> | V <sub>DDQ</sub> | V <sub>DDQ</sub> | DQPf | DQPb |
| <b>F</b> | DQc  | DQc  | V <sub>SS</sub>  | V <sub>SS</sub>  | V <sub>SS</sub> | NC              | V <sub>SS</sub> | V <sub>SS</sub>  | V <sub>SS</sub>  | DQf  | DQf  |
| <b>G</b> | DQc  | DQc  | V <sub>DDQ</sub> | V <sub>DDQ</sub> | V <sub>DD</sub> | NC              | V <sub>DD</sub> | V <sub>DDQ</sub> | V <sub>DDQ</sub> | DQf  | DQf  |
| <b>H</b> | DQc  | DQc  | V <sub>SS</sub>  | V <sub>SS</sub>  | V <sub>SS</sub> | NC              | V <sub>SS</sub> | V <sub>SS</sub>  | V <sub>SS</sub>  | DQf  | DQf  |
| <b>J</b> | DQc  | DQc  | V <sub>DDQ</sub> | V <sub>DDQ</sub> | V <sub>DD</sub> | NC              | V <sub>DD</sub> | V <sub>DDQ</sub> | V <sub>DDQ</sub> | DQf  | DQf  |
| <b>K</b> | NC   | NC   | CLK              | NC               | V <sub>SS</sub> | CEN             | V <sub>SS</sub> | NC               | NC               | NC   | NC   |
| <b>L</b> | DQh  | DQh  | V <sub>DDQ</sub> | V <sub>DDQ</sub> | V <sub>DD</sub> | NC              | V <sub>DD</sub> | V <sub>DDQ</sub> | V <sub>DDQ</sub> | DQa  | DQa  |
| <b>M</b> | DQh  | DQh  | V <sub>SS</sub>  | V <sub>SS</sub>  | V <sub>SS</sub> | NC              | V <sub>SS</sub> | V <sub>SS</sub>  | V <sub>SS</sub>  | DQa  | DQa  |
| <b>N</b> | DQh  | DQh  | V <sub>DDQ</sub> | V <sub>DDQ</sub> | V <sub>DD</sub> | NC              | V <sub>DD</sub> | V <sub>DDQ</sub> | V <sub>DDQ</sub> | DQa  | DQa  |
| <b>P</b> | DQh  | DQh  | V <sub>SS</sub>  | V <sub>SS</sub>  | V <sub>SS</sub> | ZZ              | V <sub>SS</sub> | V <sub>SS</sub>  | V <sub>SS</sub>  | DQa  | DQa  |
| <b>R</b> | DQPd | DQPh | V <sub>DDQ</sub> | V <sub>DDQ</sub> | V <sub>DD</sub> | V <sub>DD</sub> | V <sub>DD</sub> | V <sub>DDQ</sub> | V <sub>DDQ</sub> | DQPa | DQPe |
| <b>T</b> | DQd  | DQd  | V <sub>SS</sub>  | NC               | NC              | MODE            | NC              | NC               | V <sub>SS</sub>  | DQe  | DQe  |
| <b>U</b> | DQd  | DQd  | NC/144M          | A                | NC/72M          | A               | A               | A                | NC/288M          | DQe  | DQe  |
| <b>V</b> | DQd  | DQd  | A                | A                | A               | A1              | A               | A                | A                | DQe  | DQe  |
| <b>W</b> | DQd  | DQd  | TMS              | TDI              | A               | A0              | A               | TDO              | TCK              | DQe  | DQe  |



## Pin Definitions

| Pin Name   | IO                 | Description   |
|--|--------------------|---|
| A <sub>0</sub> , A <sub>1</sub> , A  | Input-Synchronous  | <b>Address Inputs.</b> Used to select one of the address locations. Sampled at the rising edge of the CLK. A <sub>[1:0]</sub> are fed to the two-bit burst counter.   |
| $\overline{BW}_A$ , $\overline{BW}_B$ ,<br>$\overline{BW}_C$ , $\overline{BW}_D$ ,<br>$\overline{BW}_E$ , $\overline{BW}_F$ ,<br>$\overline{BW}_G$ , $\overline{BW}_H$ | Input-Synchronous  | <b>Byte Write Inputs, Active LOW.</b> Qualified with $\overline{WE}$ to conduct writes to the SRAM. Sampled on the rising edge of CLK.  |
| $\overline{WE}$  | Input-Synchronous  | <b>Write Enable Input, Active LOW.</b> Sampled on the rising edge of CLK if $\overline{CEN}$ is active LOW. This signal must be asserted LOW to initiate a write sequence.  |
| ADV/LD   | Input-Synchronous  | <b>Advance or Load Input.</b> Used to advance the on-chip address counter or load a new address. When HIGH (and $\overline{CEN}$ is asserted LOW) the internal burst counter is advanced. When LOW, a new address can be loaded into the device for an access. After deselection, drive ADV/LD LOW to load a new address.   |
| CLK  | Input-Clock        | <b>Clock Input.</b> Used to capture all synchronous inputs to the device. CLK is qualified with $\overline{CEN}$ . CLK is only recognized if $\overline{CEN}$ is active LOW.  |
| $\overline{CE}_1$  | Input-Synchronous  | <b>Chip Enable 1 Input, Active LOW.</b> Sampled on the rising edge of CLK. Used in conjunction with $\overline{CE}_2$ and $\overline{CE}_3$ to select or deselect the device.   |
| $\overline{CE}_2$  | Input-Synchronous  | <b>Chip Enable 2 Input, Active HIGH.</b> Sampled on the rising edge of CLK. Used in conjunction with $\overline{CE}_1$ and $\overline{CE}_3$ to select or deselect the device.  |
| $\overline{CE}_3$  | Input-Synchronous  | <b>Chip Enable 3 Input, Active LOW.</b> Sampled on the rising edge of CLK. Used in conjunction with $\overline{CE}_1$ and $\overline{CE}_2$ to select or deselect the device.   |
| $\overline{OE}$  | Input-Asynchronous | <b>Output Enable, Asynchronous Input, Active LOW.</b> Combined with the synchronous logic block inside the device to control the direction of the IO pins. When LOW, the IO pins are allowed to behave as outputs. When deasserted HIGH, IO pins are tri-stated and act as input data pins. OE is masked during the data portion of a write sequence, during the first clock when emerging from a deselected state, and when the device is deselected.  |
| $\overline{CEN}$   | Input-Synchronous  | <b>Clock Enable Input, Active LOW.</b> When asserted LOW the clock signal is recognized by the SRAM. When deasserted HIGH the clock signal is masked. Because deasserting $\overline{CEN}$ does not deselect the device, use $\overline{CEN}$ to extend the previous cycle when required.   |
| ZZ   | Input-Asynchronous | <b>ZZ “Sleep” Input.</b> This active HIGH input places the device in a non time critical sleep condition with data integrity preserved. During normal operation, this pin has to be LOW or left floating. ZZ pin has an internal pull down.   |
| DQ <sub>s</sub>  | IO-Synchronous     | <b>Bidirectional Data IO lines.</b> As inputs, they feed into an on-chip data register that is triggered by the rising edge of CLK. As outputs, they deliver the data contained in the memory location specified by the addresses presented during the previous clock rise of the read cycle. The direction of the pins is controlled by $\overline{OE}$ . When $\overline{OE}$ is asserted LOW, the pins behave as outputs. When HIGH, DQ <sub>s</sub> and DQP <sub>[A:D]</sub> are placed in a tri-state condition. The outputs are automatically tri-stated during the data portion of a write sequence, during the first clock when emerging from a deselected state, and when the device is deselected, regardless of the state of $\overline{OE}$ . |
| DQP <sub>x</sub>   | IO-Synchronous     | <b>Bidirectional Data Parity IO Lines.</b> Functionally, these signals are identical to DQ <sub>s</sub> . During write sequences, DQP <sub>x</sub> is controlled by $\overline{BW}_x$ correspondingly.  |
| MODE   | Input Strap Pin    | <b>Mode Input.</b> Selects the burst order of the device. When tied to Gnd selects linear burst sequence. When tied to V <sub>DD</sub> or left floating selects interleaved burst sequence.   |
| V <sub>DD</sub>  | Power Supply       | <b>Power Supply Inputs to the Core of the Device.</b>   |
| V <sub>DDQ</sub>   | IO Power Supply    | <b>Power Supply for IO Circuitry.</b>   |
| V <sub>SS</sub>  | Ground             | <b>Ground for the Device.</b>   |

## Pin Definitions (continued)

| Pin Name | IO                             | Description   |
|----------|--------------------------------|---|
| TDO      | JTAG Serial Output Synchronous | <b>Serial Data-Out to the JTAG Circuit.</b> Delivers data on the negative edge of TCK. If the JTAG feature is not used, leave this pin unconnected. This pin is not available on TQFP packages.   |
| TDI      | JTAG Serial Input Synchronous  | <b>Serial Data-In to the JTAG Circuit.</b> Sampled on the rising edge of TCK. If the JTAG feature is not used, this pin can be left floating or connected to $V_{DD}$ through a pull up resistor. This pin is not available on TQFP packages. |
| TMS      | JTAG Serial Input Synchronous  | <b>Serial Data-In to the JTAG Circuit.</b> Sampled on the rising edge of TCK. If the JTAG feature is not used, this pin can be disconnected or connected to $V_{DD}$ . This pin is not available on TQFP packages.                            |
| TCK      | JTAG-Clock                     | <b>Clock Input to the JTAG Circuitry.</b> If the JTAG feature is not used, this pin must be connected to $V_{SS}$ . This pin is not available on TQFP packages.   |
| NC       | N/A                            | <b>No Connects.</b> Not internally connected to the die.  |
| NC/72M   | N/A                            | <b>Not Connected to the Die.</b> Can be tied to any voltage level.  |
| NC/144M  | N/A                            | <b>Not Connected to the Die.</b> Can be tied to any voltage level.  |
| NC/288M  | N/A                            | <b>Not Connected to the Die.</b> Can be tied to any voltage level.  |
| NC/576M  | N/A                            | <b>Not Connected to the Die.</b> Can be tied to any voltage level.  |
| NC/1G    | N/A                            | <b>Not Connected to the Die.</b> Can be tied to any voltage level.  |

## Functional Overview

The CY7C1461AV33/CY7C1463AV33/CY7C1465AV33 is a synchronous flow through burst SRAM designed specifically to eliminate wait states during Write-Read transitions. All synchronous inputs pass through input registers controlled by the rising edge of the clock. The clock signal is qualified with the clock enable input signal ( $\overline{CEN}$ ). If  $\overline{CEN}$  is HIGH, the clock signal is not recognized and all internal states are maintained. All synchronous operations are qualified with  $\overline{CEN}$ . Maximum access delay from the clock rise ( $t_{CDV}$ ) is 6.5 ns (133 MHz device).

Accesses can be initiated by asserting all three chip enables ( $\overline{CE}_1$ ,  $\overline{CE}_2$ ,  $\overline{CE}_3$ ) active at the rising edge of the clock. If  $\overline{CEN}$  is active LOW and  $\overline{ADV/LD}$  is asserted LOW, the address presented to the device is latched. The access can either be a read or write operation, depending on the status of the write enable ( $\overline{WE}$ ).  $\overline{BW}_X$  can be used to conduct byte write operations.

Write operations are qualified by the Write Enable ( $\overline{WE}$ ). All writes are simplified with on-chip synchronous self timed write circuitry.

Three synchronous chip enables ( $\overline{CE}_1$ ,  $\overline{CE}_2$ ,  $\overline{CE}_3$ ) and an asynchronous output enable ( $\overline{OE}$ ) simplify depth expansion. All operations (reads, writes, and deselections) are pipelined.  $\overline{ADV/LD}$  must be driven LOW after the device is deselected to load a new address for the next operation.

### Single Read Accesses

A read access is initiated when these conditions are satisfied at clock rise:

- $\overline{CEN}$  is asserted LOW

- $\overline{CE}_1$ ,  $\overline{CE}_2$ , and  $\overline{CE}_3$  are ALL asserted active

- The write enable input signal  $\overline{WE}$  is deasserted HIGH

- $\overline{ADV/LD}$  is asserted LOW

The address presented to the address inputs is latched into the address register and presented to the memory array and control logic. The control logic determines that a read access is in progress and allows the requested data to propagate to the output buffers. The data is available within 6.5 ns (133 MHz device) provided  $\overline{OE}$  is active LOW. After the first clock of the read access, the output buffers are controlled by  $\overline{OE}$  and the internal control logic.  $\overline{OE}$  must be driven LOW for the device to drive out the requested data. On the subsequent clock, another operation (Read/Write/Deselect) can be initiated. When the SRAM is deselected at clock rise by one of the chip enable signals, its output is tri-stated immediately.

### Burst Read Accesses

The CY7C1461AV33/CY7C1463AV33/CY7C1465AV33 has an on-chip burst counter that provides the ability to supply a single address and conduct up to four reads without reasserting the address inputs.  $\overline{ADV/LD}$  must be driven LOW to load a new address into the SRAM, as described in the [Single Read Accesses](#) section. The sequence of the burst counter is determined by the MODE input signal. A LOW input on MODE selects a linear burst mode, a HIGH selects an interleaved burst sequence. Both burst counters use A0 and A1 in the burst sequence, and wraps around when incremented sufficiently. A HIGH input on  $\overline{ADV/LD}$  increments the internal burst counter regardless of the state of chip enable inputs or  $\overline{WE}$ .  $\overline{WE}$  is latched at the beginning of a burst cycle. Therefore, the type of access (read or write) is maintained throughout the burst sequence.

### Single Write Accesses

Write access are initiated when the following conditions are satisfied at clock rise: (1)  $\overline{CEN}$  is asserted LOW, (2)  $\overline{CE}_1$ ,  $\overline{CE}_2$ , and  $\overline{CE}_3$  are ALL asserted active, and (3) the write signal  $\overline{WE}$  is asserted LOW. The address presented to the address bus is loaded into the address register. The write signals are latched into the control logic block. The data lines are automatically tri-stated regardless of the state of the  $\overline{OE}$  input signal. This allows the external logic to present the data on DQs and DQP<sub>X</sub>.

On the next clock rise the data presented to DQs and DQP<sub>X</sub> (or a subset for byte write operations, see [Truth Table](#) for details) inputs is latched into the device and the write is complete. Additional accesses (read/write/deselect) can be initiated on this cycle.

The data written during the write operation is controlled by  $\overline{BW}_X$  signals. The CY7C1461AV33/CY7C1463AV33/CY7C1465AV33 provides byte write capability that is described in the truth table. Asserting the ( $\overline{WE}$ ) with the selected byte write select input selectively writes to only the desired bytes. Bytes not selected during a byte write operation remains unaltered. A synchronous self timed write mechanism is provided to simplify the write operations. Byte write capability is included to greatly simplify Read/Modify/Write sequences, which can be reduced to simple byte write operations.

Because the CY7C1461AV33/CY7C1463AV33/CY7C1465AV33 is a common IO device, data must not be driven into the device when the outputs are active. The  $\overline{OE}$  can be deasserted HIGH before presenting data to the DQs and DQP<sub>X</sub> inputs. This tri-states the output drivers. As a safety precaution, DQs and DQP<sub>X</sub> are automatically tri-stated during the data portion of a write cycle, regardless of the state of  $\overline{OE}$ .

### Burst Write Accesses

The CY7C1461AV33/CY7C1463AV33/CY7C1465AV33 has an on-chip burst counter that provides the ability to supply a single address and conduct up to four write operations without reasserting the address inputs.  $\overline{ADV/LD}$  must be driven LOW to load the initial address, as described in the [Single Write Accesses](#) section. When  $\overline{ADV/LD}$  is driven HIGH on the

subsequent clock rise, the chip enables ( $\overline{CE}_1$ ,  $\overline{CE}_2$ , and  $\overline{CE}_3$ ) and  $\overline{WE}$  inputs are ignored and the burst counter is incremented. The correct  $\overline{BW}_X$  inputs must be driven in each cycle of the burst write, to write the correct bytes of data.

### Interleaved Burst Address Table (MODE = Floating or V<sub>DD</sub>)

| First Address<br>A1: A0 | Second Address<br>A1: A0 | Third Address<br>A1: A0 | Fourth Address<br>A1: A0 |
|-------------------------|--------------------------|-------------------------|--------------------------|
| 00                      | 01                       | 10                      | 11                       |
| 01                      | 00                       | 11                      | 10                       |
| 10                      | 11                       | 00                      | 01                       |
| 11                      | 10                       | 01                      | 00                       |

### Linear Burst Address Table (MODE = GND)

| First Address<br>A1: A0 | Second Address<br>A1: A0 | Third Address<br>A1: A0 | Fourth Address<br>A1: A0 |
|-------------------------|--------------------------|-------------------------|--------------------------|
| 00                      | 01                       | 10                      | 11                       |
| 01                      | 10                       | 11                      | 00                       |
| 10                      | 11                       | 00                      | 01                       |
| 11                      | 00                       | 01                      | 10                       |

### Sleep Mode

The ZZ input pin is an asynchronous input. Asserting ZZ places the SRAM in a power conservation sleep mode. Two clock cycles are required to enter into or exit from this sleep mode. When in this mode, data integrity is guaranteed. Accesses pending when entering the sleep mode are not considered valid nor is the completion of the operation guaranteed. The device must be deselected prior to entering the sleep mode.  $\overline{CE}_1$ ,  $\overline{CE}_2$ , and  $\overline{CE}_3$ , must remain inactive for the duration of  $t_{ZZREC}$  after the ZZ input returns LOW.

## ZZ Mode Electrical Characteristics

| Parameter   | Description                       | Test Conditions           | Min        | Max        | Unit |
|-------------|-----------------------------------|---------------------------|------------|------------|------|
| $I_{DDZZ}$  | Sleep mode standby current        | $ZZ \geq V_{DD} - 0.2 V$  | –          | 100        | mA   |
| $t_{ZZS}$   | Device operation to ZZ            | $ZZ \geq V_{DD} - 0.2 V$  | –          | $2t_{CYC}$ | ns   |
| $t_{ZZREC}$ | ZZ recovery time                  | $ZZ \leq 0.2 V$           | $2t_{CYC}$ | –          | ns   |
| $t_{ZZI}$   | ZZ active to sleep current        | This parameter is sampled | –          | $2t_{CYC}$ | ns   |
| $t_{RZZI}$  | ZZ Inactive to exit sleep current | This parameter is sampled | 0          | –          | ns   |

## Truth Table

The truth table for CY7C1461AV33/CY7C1463AV33/CY7C1465AV33 follows. [2, 3, 4, 5, 6, 7, 8]

| Operation                     | Address Used | $\overline{CE}_1$ | $CE_2$ | $\overline{CE}_3$ | ZZ | ADV/LD | $\overline{WE}$ | $\overline{BW}_x$ | $\overline{OE}$ | $\overline{CEN}$ | CLK  | DQ           |
|-------------------------------|--------------|-------------------|--------|-------------------|----|--------|-----------------|-------------------|-----------------|------------------|------|--------------|
| Deselect Cycle                | None         | H                 | X      | X                 | L  | L      | X               | X                 | X               | L                | L->H | Tri-State    |
| Deselect Cycle                | None         | X                 | X      | H                 | L  | L      | X               | X                 | X               | L                | L->H | Tri-State    |
| Deselect Cycle                | None         | X                 | L      | X                 | L  | L      | X               | X                 | X               | L                | L->H | Tri-State    |
| Continue Deselect Cycle       | None         | X                 | X      | X                 | L  | H      | X               | X                 | X               | L                | L->H | Tri-State    |
| Read Cycle (Begin Burst)      | External     | L                 | H      | L                 | L  | L      | H               | X                 | L               | L                | L->H | Data Out (Q) |
| Read Cycle (Continue Burst)   | Next         | X                 | X      | X                 | L  | H      | X               | X                 | L               | L                | L->H | Data Out (Q) |
| NOP/Dummy Read (Begin Burst)  | External     | L                 | H      | L                 | L  | L      | H               | X                 | H               | L                | L->H | Tri-State    |
| Dummy Read (Continue Burst)   | Next         | X                 | X      | X                 | L  | H      | X               | X                 | H               | L                | L->H | Tri-State    |
| Write Cycle (Begin Burst)     | External     | L                 | H      | L                 | L  | L      | L               | L                 | X               | L                | L->H | Data In (D)  |
| Write Cycle (Continue Burst)  | Next         | X                 | X      | X                 | L  | H      | X               | L                 | X               | L                | L->H | Data In (D)  |
| NOP/Write Abort (Begin Burst) | None         | L                 | H      | L                 | L  | L      | L               | H                 | X               | L                | L->H | Tri-State    |
| Write Abort (Continue Burst)  | Next         | X                 | X      | X                 | L  | H      | X               | H                 | X               | L                | L->H | Tri-State    |
| Ignore Clock Edge (Stall)     | Current      | X                 | X      | X                 | L  | X      | X               | X                 | X               | H                | L->H | -            |
| Sleep Mode                    | None         | X                 | X      | X                 | H  | X      | X               | X                 | X               | X                | X    | Tri-State    |

### Notes

- X = "Don't Care." H = logic HIGH, L = logic LOW.  $\overline{BW}_x = L$  signifies at least one byte write select is active,  $\overline{BW}_x = Valid$  signifies that the desired byte write selects are asserted, see truth table for details.
- Write is defined by  $\overline{BW}_x$  and  $\overline{WE}$ . See truth table for read or write.
- When a write cycle is detected, all IOs are tri-stated, even during byte writes.
- The DQs and  $DQP_x$  pins are controlled by the current cycle and the  $\overline{OE}$  signal.  $\overline{OE}$  is asynchronous and is not sampled with the clock.
- $\overline{CEN} = H$ , inserts wait states.
- Device powers up deselected and the IOs in a tri-state condition, regardless of  $\overline{OE}$ .
- $\overline{OE}$  is asynchronous and is not sampled with the clock rise. It is masked internally during write cycles. During a read cycle DQs and  $DQP_x = Tri-state$  when  $\overline{OE}$  is inactive or when the device is deselected, and DQs and  $DQP_x = data$  when  $\overline{OE}$  is active.

**Truth Table for Read/Write<sup>[9, 10]</sup>**

| Function (CY7C1461AV33)                                | $\overline{WE}$ | $\overline{BW}_A$ | $\overline{BW}_B$ | $\overline{BW}_C$ | $\overline{BW}_D$ |
|--|-----------------|-------------------|-------------------|-------------------|-------------------|
| Read   | H               | X                 | X                 | X                 | X                 |
| Write – No Bytes Written                               | L               | H                 | H                 | H                 | H                 |
| Write Byte A – (DQ <sub>A</sub> and DQP <sub>A</sub> ) | L               | L                 | H                 | H                 | H                 |
| Write Byte B – (DQ <sub>B</sub> and DQP <sub>B</sub> ) | L               | H                 | L                 | H                 | H                 |
| Write Byte C – (DQ <sub>C</sub> and DQP <sub>C</sub> ) | L               | H                 | H                 | L                 | H                 |
| Write Byte D – (DQ <sub>D</sub> and DQP <sub>D</sub> ) | L               | H                 | H                 | H                 | L                 |
| Write All Bytes  | L               | L                 | L                 | L                 | L                 |

**Truth Table for Read/Write<sup>[9, 10]</sup>**

| Function (CY7C1463AV33)                                | $\overline{WE}$ | $\overline{BW}_b$ | $\overline{BW}_a$ |
|--|-----------------|-------------------|-------------------|
| Read   | H               | X                 | X                 |
| Write – No Bytes Written                               | L               | H                 | H                 |
| Write Byte a – (DQ <sub>a</sub> and DQP <sub>a</sub> ) | L               | H                 | L                 |
| Write Byte b – (DQ <sub>b</sub> and DQP <sub>b</sub> ) | L               | L                 | H                 |
| Write Both Bytes                                       | L               | L                 | L                 |

**Truth Table for Read/Write<sup>[9, 10]</sup>**

| Function (CY7C1465AV33)                                | $\overline{WE}$ | $\overline{BW}_x$       |
|--|-----------------|-------------------------|
| Read   | H               | X                       |
| Write – No Bytes Written                               | L               | H                       |
| Write Byte X – (DQ <sub>x</sub> and DQP <sub>x</sub> ) | L               | L                       |
| Write All Bytes  | L               | All $\overline{BW} = L$ |

**Notes**

9. X = "Don't Care." H = logic HIGH, L = logic LOW.  $\overline{BW}_x = L$  signifies at least one byte write select is active,  $\overline{BW}_x = \text{Valid}$  signifies that the desired byte write selects are asserted, see truth table for details.
10. Table only lists a partial listing of the byte write combinations. Any combination of  $\overline{BW}_x$  is valid. Appropriate write is done based on which byte write is active

## IEEE 1149.1 Serial Boundary Scan (JTAG)

The CY7C1461AV33/CY7C1463AV33/CY7C1465AV33 incorporates a serial boundary scan test access port (TAP). This part is fully compliant with 1149.1. The TAP operates using JEDEC-standard 3.3 V and 2.5 V IO logic level.

The CY7C1461AV33/CY7C1463AV33/CY7C1465AV33 contains a TAP controller, instruction register, boundary scan register, bypass register, and ID register.

### Disabling the JTAG Feature

It is possible to operate the SRAM without using the JTAG feature. To disable the TAP controller, TCK must be tied LOW ( $V_{SS}$ ) to prevent clocking of the device. TDI and TMS are internally pulled up and may be unconnected. They may alternately be connected to  $V_{DD}$  through a pull up resistor. TDO must be left unconnected. On power up, the device is up in a reset state which does not interfere with the operation of the device.

### TAP Controller State Diagram

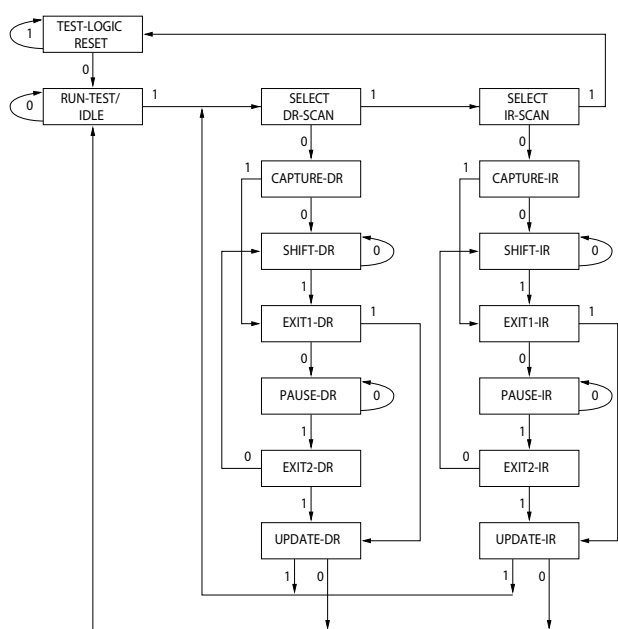

The 0/1 next to each state represents the value of TMS at the rising edge of TCK.

### Test Access Port (TAP)

#### Test Clock (TCK)

The test clock is used only with the TAP controller. All inputs are captured on the rising edge of TCK. All outputs are driven from the falling edge of TCK.

#### Test Mode Select (TMS)

The TMS input is used to give commands to the TAP controller and is sampled on the rising edge of TCK. It is allowable to leave this ball unconnected if the TAP is not used. The ball is pulled up internally, resulting in a logic HIGH level.

#### Test Data-In (TDI)

The TDI ball is used to serially input information into the registers and can be connected to the input of any of the registers. The register between TDI and TDO is chosen by the instruction that is loaded into the TAP instruction register. TDI is internally pulled up and can be unconnected if the TAP is unused in an application. TDI is connected to the most significant bit (MSB) of any register (see [TAP Controller Block Diagram](#)).

#### Test Data-Out (TDO)

The TDO output ball is used to serially clock data-out from the registers. The output is active depending on the current state of the TAP state machine. The output changes on the falling edge of TCK. TDO is connected to the least significant bit (LSB) of any register (see [TAP Controller State Diagram](#)).

### TAP Controller Block Diagram

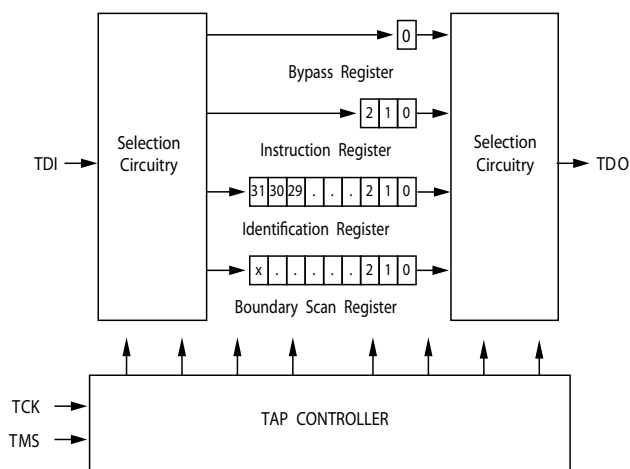

### Performing a TAP Reset

A RESET is performed by forcing TMS HIGH ( $V_{DD}$ ) for five rising edges of TCK. This RESET does not affect the operation of the SRAM and may be performed while the SRAM is operating.

At power up, the TAP is reset internally to ensure that TDO comes up in a High Z state.

### TAP Registers

Registers are connected between the TDI and TDO balls and enable data to be scanned into and out of the SRAM test circuitry. Only one register can be selected at a time through the instruction register. Data is serially loaded into the TDI ball on the rising edge of TCK. Data is output on the TDO ball on the falling edge of TCK.

#### Instruction Register

Three-bit instructions can be serially loaded into the instruction register. This register is loaded when it is placed between the TDI and TDO balls as shown in the [TAP Controller Block Diagram](#). On power up, the instruction register is loaded with the IDCODE instruction. It is also loaded with the IDCODE instruction if the controller is placed in a reset state as described in the previous section.

When the TAP controller is in the Capture-IR state, the two least significant bits are loaded with a binary “01” pattern to enable fault isolation of the board level serial test data path.

#### *Bypass Register*

To save time when serially shifting data through registers, it is sometimes advantageous to skip certain chips. The bypass register is a single-bit register that can be placed between the TDI and TDO balls. This enables data to be shifted through the SRAM with minimal delay. The bypass register is set LOW ( $V_{SS}$ ) when the BYPASS instruction is executed.

#### *Boundary Scan Register*

The boundary scan register is connected to all the input and bidirectional balls on the SRAM. The length of the boundary scan register for the SRAM in different packages is listed in the [Scan Register Sizes](#) table.

The boundary scan register is loaded with the contents of the RAM IO ring when the TAP controller is in the Capture-DR state and is then placed between the TDI and TDO balls when the controller is moved to the Shift-DR state. The EXTEST, SAMPLE/PRELOAD, and SAMPLE Z instructions can be used to capture the contents of the IO ring.

The Boundary Scan Order tables show the order in which the bits are connected. Each bit corresponds to one of the bumps on the SRAM package. The MSB of the register is connected to TDI, and the LSB is connected to TDO.

#### *Identification (ID) Register*

The ID register is loaded with a vendor-specific, 32-bit code during the Capture-DR state when the IDCODE command is loaded in the instruction register. The IDCODE is hardwired into the SRAM and can be shifted out when the TAP controller is in the Shift-DR state. The ID register has a vendor code and other information described in the [Identification Register Definitions](#) table.

### **TAP Instruction Set**

#### *Overview*

Eight different instructions are possible with the three bit instruction register. All combinations are listed in the Instruction Codes table. Three of these instructions are listed as RESERVED and must not be used. The other five instructions are described in the following section in detail.

Instructions are loaded into the TAP controller during the Shift-IR state when the instruction register is placed between TDI and TDO. During this state, instructions are shifted through the instruction register through the TDI and TDO balls. To execute the instruction after it is shifted in, the TAP controller must be moved into the Update-IR state.

#### *IDCODE*

The IDCODE instruction causes a vendor specific, 32-bit code to be loaded into the instruction register. It also places the instruction register between the TDI and TDO balls and enables the IDCODE to be shifted out of the device when the TAP controller enters the Shift-DR state.

The IDCODE instruction is loaded into the instruction register on power up or whenever the TAP controller is supplied a test logic reset state.

#### *SAMPLE Z*

The SAMPLE Z instruction causes the boundary scan register to be connected between the TDI and TDO pins when the TAP controller is in a Shift-DR state. The SAMPLE Z command puts the output bus into a High Z state until the next command is supplied during the Update IR state.

#### *SAMPLE/PRELOAD*

SAMPLE/PRELOAD is a 1149.1 mandatory instruction. When the SAMPLE/PRELOAD instructions are loaded into the instruction register and the TAP controller is in the Capture-DR state, a snapshot of data on the inputs and output pins is captured in the boundary scan register.

The TAP controller clock can only operate at a frequency up to 20 MHz, while the SRAM clock operates more than an order of magnitude faster. Because there is a large difference in the clock frequencies, it is possible that during the Capture-DR state, an input or output undergoes a transition. The TAP may then try to capture a signal while in transition (metastable state). This does not harm the device, but there is no guarantee as to the value that is captured. Repeatable results may not be possible.

To guarantee that the boundary scan register captures the correct value of a signal, the SRAM signal must be stabilized long enough to meet the TAP controller’s capture setup plus hold times ( $t_{CS}$  and  $t_{CH}$ ). The SRAM clock input might not be captured correctly if there is no way in a design to stop (or slow) the clock during a SAMPLE/PRELOAD instruction. If this is an issue, it is still possible to capture all other signals and simply ignore the value of the CK and CK captured in the boundary scan register.

After the data is captured, it is possible to shift out the data by putting the TAP into the Shift-DR state. This places the boundary scan register between the TDI and TDO pins.

PRELOAD enables an initial data pattern to be placed at the latched parallel outputs of the boundary scan register cells prior to the selection of another boundary scan test operation.

The shifting of data for the SAMPLE and PRELOAD phases can occur concurrently when required—that is, while data captured is shifted out, the preloaded data can be shifted in.

#### *BYPASS*

When the BYPASS instruction is loaded in the instruction register and the TAP is placed in a Shift-DR state, the bypass register is placed between the TDI and TDO pins. The advantage of the BYPASS instruction is that it shortens the boundary scan path when multiple devices are connected together on a board.

#### *EXTEST*

The EXTEST instruction enables the preloaded data to be driven out through the system output pins. This instruction also selects the boundary scan register to be connected for serial access between the TDI and TDO in the Shift-DR controller state.

#### *EXTEST OUTPUT BUS TRI-STATE*

IEEE Standard 1149.1 mandates that the TAP controller be able to put the output bus into a tri-state mode.

The boundary scan register has a special bit located at bit #89 (for 165-ball FBGA package) or bit #138 (for 209-ball FBGA package). When this scan cell, called the “extest output bus tri-state”, is latched into the preload register during the “Update-DR” state in the TAP controller, it directly controls the state of the output (Q-bus) pins when the EXTEST is entered as the current instruction. When HIGH, it enables the output buffers to drive the output bus. When LOW, this bit places the output bus into a High Z condition.

This bit can be set by entering the SAMPLE/PRELOAD or EXTEST command and then shifting the desired bit into that cell,

during the Shift-DR state. During Update-DR, the value loaded into that shift register cell latches into the preload register. When the EXTEST instruction is entered, this bit directly controls the output Q-bus pins. Note that this bit is pre-set HIGH to enable the output when the device is powered-up, and also when the TAP controller is in the Test-Logic-Reset state.

**Reserved**

These instructions are not implemented but are reserved for future use. Do not use these instructions.

**TAP Timing**

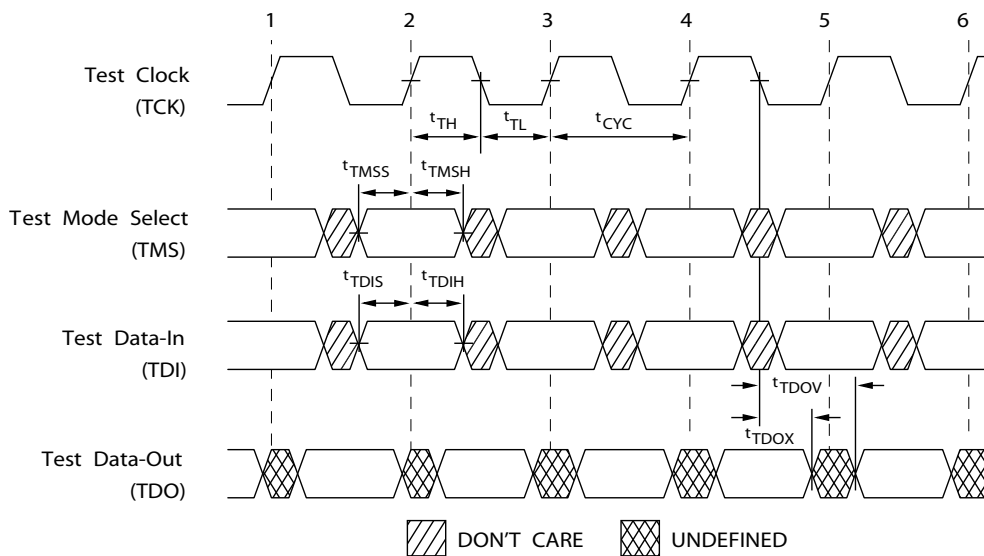



## TAP AC Switching Characteristics

Over the Operating Range<sup>[11, 12]</sup>

| Parameter           | Description                   | Min | Max | Unit |
|---------------------|-------------------------------|-----|-----|------|
| <b>Clock</b>        |                               |     |     |      |
| $t_{TCYC}$          | TCK Clock Cycle Time          | 50  | –   | ns   |
| $t_{TF}$            | TCK Clock Frequency           | –   | 20  | MHz  |
| $t_{TH}$            | TCK Clock HIGH time           | 20  | –   | ns   |
| $t_{TL}$            | TCK Clock LOW time            | 20  | –   | ns   |
| <b>Output Times</b> |                               |     |     |      |
| $t_{TDOV}$          | TCK Clock LOW to TDO Valid    | –   | 10  | ns   |
| $t_{TDOX}$          | TCK Clock LOW to TDO Invalid  | 0   | –   | ns   |
| <b>Setup Times</b>  |                               |     |     |      |
| $t_{TMSS}$          | TMS Setup to TCK Clock Rise   | 5   | –   | ns   |
| $t_{TDIS}$          | TDI Setup to TCK Clock Rise   | 5   | –   | ns   |
| $t_{CS}$            | Capture Setup to TCK Rise     | 5   | –   | ns   |
| <b>Hold Times</b>   |                               |     |     |      |
| $t_{TMSh}$          | TMS Hold after TCK Clock Rise | 5   | –   | ns   |
| $t_{TDIH}$          | TDI Hold after Clock Rise     | 5   | –   | ns   |
| $t_{CH}$            | Capture Hold after Clock Rise | 5   | –   | ns   |

### Notes

11.  $t_{CS}$  and  $t_{CH}$  refer to the setup and hold time requirements of latching data from the boundary scan register.  
 12. Test conditions are specified using the load in TAP AC test Conditions.  $t_R/t_F = 1$  ns.

### 3.3 V TAP AC Test Conditions

Input pulse levels .....  $V_{SS}$  to 3.3 V  
 Input rise and fall times ..... 1 ns  
 Input timing reference levels ..... 1.5 V  
 Output reference levels ..... 1.5 V  
 Test load termination supply voltage ..... 1.5 V

### 3.3 V TAP AC Output Load Equivalent

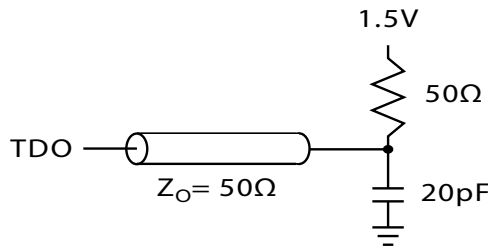

### 2.5 V TAP AC Test Conditions

Input pulse levels .....  $V_{SS}$  to 2.5 V  
 Input rise and fall time ..... 1 ns  
 Input timing reference levels ..... 1.25 V  
 Output reference levels ..... 1.25 V  
 Test load termination supply voltage ..... 1.25 V

### 2.5 V TAP AC Output Load Equivalent

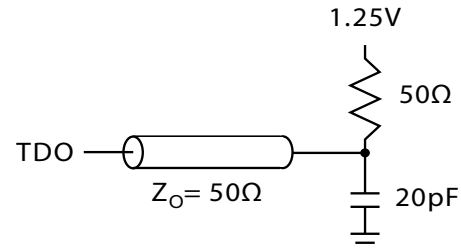

## TAP DC Electrical Characteristics and Operating Conditions

( $0\text{ }^{\circ}\text{C} < T_A < +70\text{ }^{\circ}\text{C}$ ;  $V_{DD} = 3.135$  to  $3.6\text{ V}$  unless otherwise noted)<sup>[13]</sup>

| Parameter        | Description         | Test Conditions                                     | Min                      | Max  | Unit                  |   |
|------------------|---------------------|---|--------------------------|------|-----------------------|---|
| V <sub>OH1</sub> | Output HIGH Voltage | I <sub>OH</sub> = -4.0 mA, V <sub>DDQ</sub> = 3.3 V | 2.4                      | -    | V                     |   |
|                  |                     | I <sub>OH</sub> = -1.0 mA, V <sub>DDQ</sub> = 2.5 V | 2.0                      | -    | V                     |   |
| V <sub>OH2</sub> | Output HIGH Voltage | I <sub>OH</sub> = -100 μA                           | V <sub>DDQ</sub> = 3.3 V | 2.9  | -                     | V |
|                  |                     |   | V <sub>DDQ</sub> = 2.5 V | 2.1  | -                     | V |
| V <sub>OL1</sub> | Output LOW Voltage  | I <sub>OL</sub> = 8.0 mA                            | V <sub>DDQ</sub> = 3.3 V | -    | 0.4                   | V |
|                  |                     | I <sub>OL</sub> = 1.0 mA                            | V <sub>DDQ</sub> = 2.5 V | -    | 0.4                   | V |
| V <sub>OL2</sub> | Output LOW Voltage  | I <sub>OL</sub> = 100 μA                            | V <sub>DDQ</sub> = 3.3 V | -    | 0.2                   | V |
|                  |                     |   | V <sub>DDQ</sub> = 2.5 V | -    | 0.2                   | V |
| V <sub>IH</sub>  | Input HIGH Voltage  |   | V <sub>DDQ</sub> = 3.3 V | 2.0  | V <sub>DD</sub> + 0.3 | V |
|                  |                     |   | V <sub>DDQ</sub> = 2.5 V | 1.7  | V <sub>DD</sub> + 0.3 | V |
| V <sub>IL</sub>  | Input LOW Voltage   |   | V <sub>DDQ</sub> = 3.3 V | -0.3 | 0.8                   | V |
|                  |                     |   | V <sub>DDQ</sub> = 2.5 V | -0.3 | 0.7                   | V |
| I <sub>X</sub>   | Input Load Current  | GND ≤ V <sub>IN</sub> ≤ V <sub>DDQ</sub>            | -5                       | 5    | μA                    |   |

**Note**  
13. All voltages referenced to V<sub>SS</sub> (GND).

### Identification Register Definitions

| Instruction Field                       | CY7C1461AV33<br>(1 M × 36) | CY7C1463AV33<br>(2 M × 18) | CY7C1465AV33<br>(512 K × 72) | Description                                 |
|---|----------------------------|----------------------------|------------------------------|---|
| Revision Number (31:29)                 | 000                        | 000                        | 000                          | Describes the version number                |
| Device Depth (28:24) <sup>[14]</sup>    | 01011                      | 01011                      | 01011                        | Reserved for internal use                   |
| Architecture and Memory Type<br>(23:18) | 001001                     | 001001                     | 001001                       | Defines memory type and architecture        |
| Bus Width and Density(17:12)            | 100111                     | 010111                     | 110111                       | Defines width and density                   |
| Cypress JEDEC ID Code (11:1)            | 00000110100                | 00000110100                | 00000110100                  | Allows unique identification of SRAM vendor |
| ID Register Presence Indicator (0)      | 1                          | 1                          | 1                            | Indicates the presence of an ID register    |

### Scan Register Sizes

| Register Name                               | Bit Size (× 36) | Bit Size (× 18) | Bit Size (× 72) |
|---|-----------------|-----------------|-----------------|
| Instruction                                 | 3               | 3               | 3               |
| Bypass                                      | 1               | 1               | 1               |
| ID  | 32              | 32              | 32              |
| Boundary Scan Order (165-ball FBGA Package) | 89              | 89              | –               |
| Boundary Scan Order (209-ball FBGA Package) | –               | –               | 138             |

### Identification Codes

| Instruction    | Code | Description  |
|----------------|------|--|
| EXTEST         | 000  | Captures IO ring contents. Places the boundary scan register between TDI and TDO. Forces all SRAM outputs to High Z state.                 |
| IDCODE         | 001  | Loads the ID register with the vendor ID code and places the register between TDI and TDO. This operation does not affect SRAM operations. |
| SAMPLE Z       | 010  | Captures IO ring contents. Places the boundary scan register between TDI and TDO. Forces all SRAM output drivers to a High Z state.        |
| RESERVED       | 011  | Do Not Use: This instruction is reserved for future use.   |
| SAMPLE/PRELOAD | 100  | Captures IO ring contents. Places the boundary scan register between TDI and TDO. Does not affect SRAM operation.                          |
| RESERVED       | 101  | Do Not Use: This instruction is reserved for future use.   |
| RESERVED       | 110  | Do Not Use: This instruction is reserved for future use.   |
| BYPASS         | 111  | Places the bypass register between TDI and TDO. This operation does not affect SRAM operations.  |

**Note**

14. Bit #24 is "1" in the ID Register Definitions for both 2.5 V and 3.3 V versions of this device.



**209-ball FBGA Boundary Scan Order <sup>[16]</sup>**

**CY7C1465AV33 (512 K × 72)**

| Bit# | Ball ID |
|------|---------|
| 1    | W6      |
| 2    | V6      |
| 3    | U6      |
| 4    | W7      |
| 5    | V7      |
| 6    | U7      |
| 7    | T7      |
| 8    | V8      |
| 9    | U8      |
| 10   | T8      |
| 11   | V9      |
| 12   | U9      |
| 13   | P6      |
| 14   | W11     |
| 15   | W10     |
| 16   | V11     |
| 17   | V10     |
| 18   | U11     |
| 19   | U10     |
| 20   | T11     |
| 21   | T10     |
| 22   | R11     |
| 23   | R10     |
| 24   | P11     |
| 25   | P10     |
| 26   | N11     |
| 27   | N10     |
| 28   | M11     |
| 29   | M10     |
| 30   | L11     |
| 31   | L10     |
| 32   | K11     |
| 33   | M6      |
| 34   | L6      |
| 35   | J6      |

| Bit# | Ball ID |
|------|---------|
| 36   | F6      |
| 37   | K8      |
| 38   | K9      |
| 39   | K10     |
| 40   | J11     |
| 41   | J10     |
| 42   | H11     |
| 43   | H10     |
| 44   | G11     |
| 45   | G10     |
| 46   | F11     |
| 47   | F10     |
| 48   | E10     |
| 49   | E11     |
| 50   | D11     |
| 51   | D10     |
| 52   | C11     |
| 53   | C10     |
| 54   | B11     |
| 55   | B10     |
| 56   | A11     |
| 57   | A10     |
| 58   | C9      |
| 59   | B9      |
| 60   | A9      |
| 61   | D8      |
| 62   | C8      |
| 63   | B8      |
| 64   | A8      |
| 65   | D7      |
| 66   | C7      |
| 67   | B7      |
| 68   | A7      |
| 69   | D6      |
| 70   | G6      |

| Bit# | Ball ID |
|------|---------|
| 71   | H6      |
| 72   | C6      |
| 73   | B6      |
| 74   | A6      |
| 75   | A5      |
| 76   | B5      |
| 77   | C5      |
| 78   | D5      |
| 79   | D4      |
| 80   | C4      |
| 81   | A4      |
| 82   | B4      |
| 83   | C3      |
| 84   | B3      |
| 85   | A3      |
| 86   | A2      |
| 87   | A1      |
| 88   | B2      |
| 89   | B1      |
| 90   | C2      |
| 91   | C1      |
| 92   | D2      |
| 93   | D1      |
| 94   | E1      |
| 95   | E2      |
| 96   | F2      |
| 97   | F1      |
| 98   | G1      |
| 99   | G2      |
| 100  | H2      |
| 101  | H1      |
| 102  | J2      |
| 103  | J1      |
| 104  | K1      |
| 105  | N6      |

| Bit# | Ball ID  |
|------|----------|
| 106  | K3       |
| 107  | K4       |
| 108  | K6       |
| 109  | K2       |
| 110  | L2       |
| 111  | L1       |
| 112  | M2       |
| 113  | M1       |
| 114  | N2       |
| 115  | N1       |
| 116  | P2       |
| 117  | P1       |
| 118  | R2       |
| 119  | R1       |
| 120  | T2       |
| 121  | T1       |
| 122  | U2       |
| 123  | U1       |
| 124  | V2       |
| 125  | V1       |
| 126  | W2       |
| 127  | W1       |
| 128  | T6       |
| 129  | U3       |
| 130  | V3       |
| 131  | T4       |
| 132  | T5       |
| 133  | U4       |
| 134  | V4       |
| 135  | W5       |
| 136  | V5       |
| 137  | U5       |
| 138  | Internal |
|      |          |
|      |          |

**Note**  
16. Bit# 138 is preset HIGH.

## Maximum Ratings

Exceeding maximum ratings may impair the useful life of the device. These user guidelines are not tested.

Storage Temperature ..... -65 °C to +150 °C  
 Ambient Temperature with  
 Power Applied ..... -55 °C to +125 °C  
 Supply Voltage on V<sub>DD</sub> Relative to GND ..... -0.5 V to +4.6 V  
 Supply Voltage on V<sub>DDQ</sub> Relative to GND ..... -0.5 V to +V<sub>DD</sub>  
 DC Voltage Applied to Outputs  
 in Tri-State ..... -0.5 V to V<sub>DDQ</sub> + 0.5 V

DC Input Voltage ..... -0.5 V to V<sub>DD</sub> + 0.5 V  
 Current into Outputs (LOW)..... 20 mA  
 Static Discharge Voltage..... > 2001 V  
 (MIL-STD-883, Method 3015)  
 Latch Up Current ..... > 200 mA

## Operating Range

| Range      | Ambient Temperature | V <sub>DD</sub>    | V <sub>DDQ</sub>              |
|------------|---------------------|--------------------|-------------------------------|
| Commercial | 0 °C to +70 °C      | 3.3 V – 5% / + 10% | 2.5 V – 5% to V <sub>DD</sub> |
| Industrial | -40 °C to +85 °C    |                    |                               |

## Electrical Characteristics

Over the Operating Range<sup>[17, 18]</sup>

| Parameter               | Description                                 | Test Conditions   | Min                   | Max                     | Unit |    |
|-------------------------|---|---|-----------------------|-------------------------|------|----|
| V <sub>DD</sub>         | Power Supply Voltage                        |   | 3.135                 | 3.6                     | V    |    |
| V <sub>DDQ</sub>        | IO Supply Voltage                           | for 3.3 V IO  | 3.135                 | V <sub>DD</sub>         | V    |    |
|                         |   | for 2.5 V IO  | 2.375                 | 2.625                   | V    |    |
| V <sub>OH</sub>         | Output HIGH Voltage                         | for 3.3 V IO, I <sub>OH</sub> = -4.0 mA   | 2.4                   | -                       | V    |    |
|                         |   | for 2.5 V IO, I <sub>OH</sub> = -1.0 mA   | 2.0                   | -                       | V    |    |
| V <sub>OL</sub>         | Output LOW Voltage                          | for 3.3 V IO, I <sub>OL</sub> = 8.0 mA  | -                     | 0.4                     | V    |    |
|                         |   | for 2.5 V IO, I <sub>OL</sub> = 1.0 mA  | -                     | 0.4                     | V    |    |
| V <sub>IH</sub>         | Input HIGH Voltage <sup>[17]</sup>          | for 3.3 V IO  | 2.0                   | V <sub>DD</sub> + 0.3 V | V    |    |
|                         |   | for 2.5 V IO  | 1.7                   | V <sub>DD</sub> + 0.3 V | V    |    |
| V <sub>IL</sub>         | Input LOW Voltage <sup>[17]</sup>           | for 3.3 V IO  | -0.3                  | 0.8                     | V    |    |
|                         |   | for 2.5 V IO  | -0.3                  | 0.7                     | V    |    |
| I <sub>X</sub>          | Input Leakage Current except ZZ and MODE    | GND ≤ V <sub>I</sub> ≤ V <sub>DDQ</sub>   | -5                    | 5                       | μA   |    |
|                         | Input Current of MODE                       | Input = V <sub>SS</sub>   | -30                   | -                       | μA   |    |
|                         |   | Input = V <sub>DD</sub>   | -                     | 5                       | μA   |    |
|                         | Input Current of ZZ                         | Input = V <sub>SS</sub>   | -5                    | -                       | μA   |    |
| Input = V <sub>DD</sub> |   | -   | 30                    | μA                      |      |    |
| I <sub>OZ</sub>         | Output Leakage Current                      | GND ≤ V <sub>I</sub> ≤ V <sub>DDQ</sub> , Output Disabled   | -5                    | 5                       | μA   |    |
| I <sub>DD</sub>         | V <sub>DD</sub> Operating Supply Current    | V <sub>DD</sub> = Max, I <sub>OUT</sub> = 0 mA, f = f <sub>MAX</sub> = 1/t <sub>CYC</sub>   | 7.5 ns cycle, 133 MHz | -                       | 310  | mA |
|                         |   |   | 10 ns cycle, 100 MHz  | -                       | 290  | mA |
| I <sub>SB1</sub>        | Automatic CE Power Down Current—TTL Inputs  | V <sub>DD</sub> = Max, Device Deselected, V <sub>IN</sub> ≥ V <sub>IH</sub> or V <sub>IN</sub> ≤ V <sub>IL</sub> ; f = f <sub>MAX</sub> , Inputs Switching  | 7.5 ns cycle, 133 MHz | -                       | 180  | mA |
|                         |   |   | 10 ns cycle, 100 MHz  | -                       | 180  | mA |
| I <sub>SB2</sub>        | Automatic CE Power Down Current—CMOS Inputs | V <sub>DD</sub> = Max, Device Deselected, V <sub>IN</sub> ≤ 0.3 V or V <sub>IN</sub> ≥ V <sub>DD</sub> - 0.3 V, f = 0, Inputs Static                        | -                     | 120                     | mA   |    |
| I <sub>SB3</sub>        | Automatic CE Power Down Current—CMOS Inputs | V <sub>DD</sub> = Max, Device Deselected, or V <sub>IN</sub> ≤ 0.3 V or V <sub>IN</sub> ≥ V <sub>DDQ</sub> - 0.3 V, f = f <sub>MAX</sub> , Inputs Switching | 7.5 ns cycle, 133 MHz | -                       | 180  | mA |
|                         |   |   | 10 ns cycle, 100 MHz  | -                       | 180  | mA |
| I <sub>SB4</sub>        | Automatic CE Power Down Current—TTL Inputs  | V <sub>DD</sub> = Max, Device Deselected, V <sub>IN</sub> ≥ V <sub>DD</sub> - 0.3 V or V <sub>IN</sub> ≤ 0.3 V, f = 0, Inputs Static                        | -                     | 135                     | mA   |    |

### Notes

17. Overshoot: V<sub>IH</sub>(AC) < V<sub>DD</sub> + 1.5 V (Pulse width less than t<sub>CYC</sub>/2), undershoot: V<sub>IL</sub>(AC) > -2 V (Pulse width less than t<sub>CYC</sub>/2).  
 18. T<sub>Power-up</sub>: Assumes a linear ramp from 0 V to V<sub>DD</sub>(min.) within 200 ms. During this time V<sub>IH</sub> < V<sub>DD</sub> and V<sub>DDQ</sub> ≤ V<sub>DD</sub>.

## Capacitance

In the following table, the capacitance parameters are listed.<sup>[19]</sup>

| Parameter        | Description              | Test Conditions  | 100-pin TQFP Max | 165-ball FBGA Max | 209-ball FBGA Max | Unit |
|------------------|--------------------------|--|------------------|-------------------|-------------------|------|
| C <sub>IN</sub>  | Input Capacitance        | T <sub>A</sub> = 25°C, f = 1 MHz,<br>V <sub>DD</sub> = 3.3V<br>V <sub>DDQ</sub> = 2.5V | 6.5              | 7                 | 5                 | pF   |
| C <sub>CLK</sub> | Clock Input Capacitance  |  | 3                | 7                 | 5                 | pF   |
| C <sub>IO</sub>  | Input/Output Capacitance |  | 5.5              | 6                 | 7                 | pF   |

## Thermal Resistance

In the following table, the thermal resistance parameters are listed<sup>[19]</sup>

| Parameter       | Description                              | Test Conditions   | 100-pin TQFP Package | 165-ball FBGA Package | 209-ball FBGA Package | Unit |
|-----------------|--|---|----------------------|-----------------------|-----------------------|------|
| Θ <sub>JA</sub> | Thermal Resistance (Junction to Ambient) | Test conditions follow standard test methods and procedures for measuring thermal impedance, according to EIA/JESD51. | 25.21                | 20.8                  | 25.31                 | °C/W |
| Θ <sub>JC</sub> | Thermal Resistance (Junction to Case)    |   | 2.28                 | 3.2                   | 4.48                  | °C/W |

Figure 1. AC Test Loads and Waveforms

### 3.3V IO Test Load

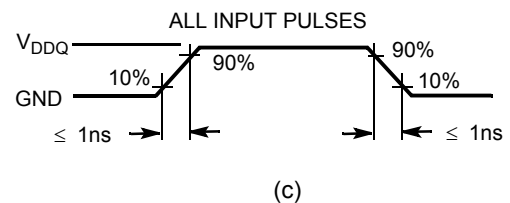
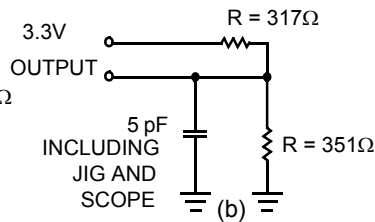
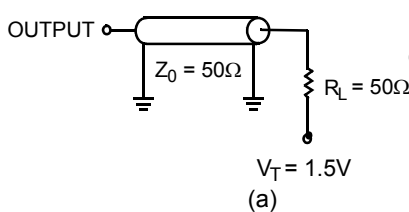

### 2.5V IO Test Load

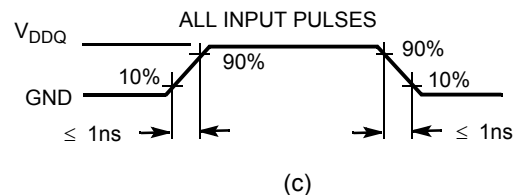
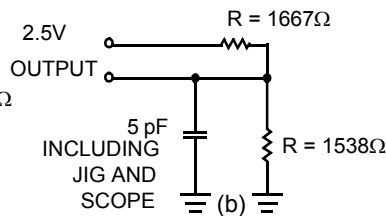
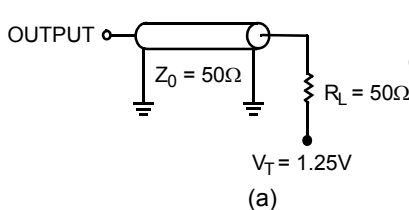

**Note**

19. Tested initially and after any design or process change that may affect these parameters.

## Switching Characteristics

 Over the Operating Range<sup>[20, 21]</sup>

| Parameter           | Description   | 133 MHz |     | 100 MHz |     | Unit |
|---------------------|---|---------|-----|---------|-----|------|
|                     |   | Min     | Max | Min     | Max |      |
| $t_{POWER}^{[22]}$  |   | 1       | –   | 1       | –   | ms   |
| <b>Clock</b>        |   |         |     |         |     |      |
| $t_{CYC}$           | Clock Cycle Time  | 7.5     | –   | 10      | –   | ns   |
| $t_{CH}$            | Clock HIGH  | 2.5     | –   | 3.0     | –   | ns   |
| $t_{CL}$            | Clock LOW   | 2.5     | –   | 3.0     | –   | ns   |
| <b>Output Times</b> |   |         |     |         |     |      |
| $t_{CDV}$           | Data Output Valid After CLK Rise                              | –       | 6.5 | –       | 8.5 | ns   |
| $t_{DOH}$           | Data Output Hold After CLK Rise                               | 2.5     | –   | 2.5     | –   | ns   |
| $t_{CLZ}$           | Clock to Low Z <sup>[23, 24, 25]</sup>                        | 2.5     | –   | 2.5     | –   | ns   |
| $t_{CHZ}$           | Clock to High Z <sup>[23, 24, 25]</sup>                       | –       | 3.8 | 0       | 4.5 | ns   |
| $t_{OEV}$           | $\overline{OE}$ LOW to Output Valid                           | –       | 3.0 | –       | 3.8 | ns   |
| $t_{OELZ}$          | $\overline{OE}$ LOW to Output Low Z <sup>[23, 24, 25]</sup>   | 0       | –   | 0       | –   | ns   |
| $t_{OEZH}$          | $\overline{OE}$ HIGH to Output High Z <sup>[23, 24, 25]</sup> | –       | 3.0 | –       | 4.0 | ns   |
| <b>Setup Times</b>  |   |         |     |         |     |      |
| $t_{AS}$            | Address Setup Before CLK Rise                                 | 1.5     | –   | 1.5     | –   | ns   |
| $t_{ALS}$           | $\overline{ADV}/\overline{LD}$ Setup Before CLK Rise          | 1.5     | –   | 1.5     | –   | ns   |
| $t_{WES}$           | $\overline{WE}$ , $\overline{BW}_X$ Setup Before CLK Rise     | 1.5     | –   | 1.5     | –   | ns   |
| $t_{CENS}$          | $\overline{CEN}$ Setup Before CLK Rise                        | 1.5     | –   | 1.5     | –   | ns   |
| $t_{DS}$            | Data Input Setup Before CLK Rise                              | 1.5     | –   | 1.5     | –   | ns   |
| $t_{CES}$           | Chip Enable Setup Before CLK Rise                             | 1.5     | –   | 1.5     | –   | ns   |
| <b>Hold Times</b>   |   |         |     |         |     |      |
| $t_{AH}$            | Address Hold After CLK Rise                                   | 0.5     | –   | 0.5     | –   | ns   |
| $t_{ALH}$           | $\overline{ADV}/\overline{LD}$ Hold After CLK Rise            | 0.5     | –   | 0.5     | –   | ns   |
| $t_{WEH}$           | $\overline{WE}$ , $\overline{BW}_X$ Hold After CLK Rise       | 0.5     | –   | 0.5     | –   | ns   |
| $t_{CENH}$          | $\overline{CEN}$ Hold After CLK Rise                          | 0.5     | –   | 0.5     | –   | ns   |
| $t_{DH}$            | Data Input Hold After CLK Rise                                | 0.5     | –   | 0.5     | –   | ns   |
| $t_{CEH}$           | Chip Enable Hold After CLK Rise                               | 0.5     | –   | 0.5     | –   | ns   |

### Notes

20. Timing reference level is 1.5 V when  $V_{DDQ} = 3.3$  V and is 1.25 V when  $V_{DDQ} = 2.5$  V.

21. Test conditions shown in (a) of Figure 1 on page 23 unless otherwise noted.

22. This part has a voltage regulator internally;  $t_{POWER}$  is the time that the power needs to be supplied above  $V_{DD}$ (minimum) initially, before a read or write operation can be initiated.

23.  $t_{CHZ}$ ,  $t_{CLZ}$ ,  $t_{OELZ}$ , and  $t_{OEZH}$  are specified with AC test conditions shown in part (b) of Figure 1 on page 23. Transition is measured  $\pm 200$  mV from steady-state voltage.

24. At any voltage and temperature,  $t_{OEZH}$  is less than  $t_{OELZ}$  and  $t_{CHZ}$  is less than  $t_{CLZ}$  to eliminate bus contention between SRAMs when sharing the same data bus.

These specifications do not imply a bus contention condition, but reflect parameters guaranteed over worst case user conditions. Device is designed to achieve High Z prior to Low Z under the same system conditions.

25. This parameter is sampled and not 100% tested.



## Switching Waveforms

Figure 2. Read/Write Waveforms<sup>[26, 27, 28]</sup>

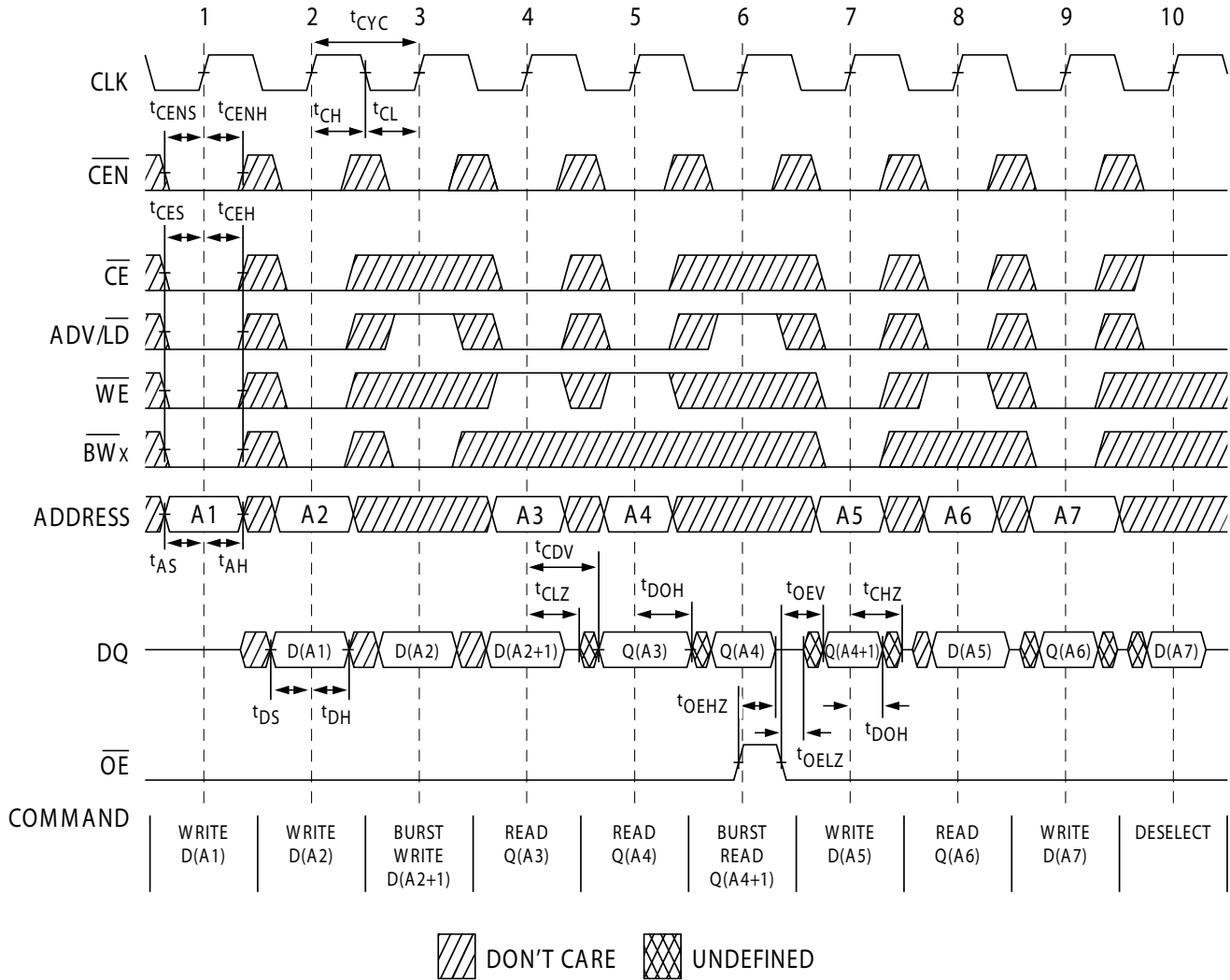

### Notes

26. For this waveform ZZ is tied LOW.

27. When  $\overline{CE}$  is LOW,  $\overline{CE}_1$  is LOW,  $\overline{CE}_2$  is HIGH and  $\overline{CE}_3$  is LOW. When  $\overline{CE}$  is HIGH,  $\overline{CE}_1$  is HIGH or  $\overline{CE}_2$  is LOW or  $\overline{CE}_3$  is HIGH.

28. Order of the burst sequence is determined by the status of the MODE (0 = Linear, 1 = Interleaved). Burst operations are optional.

**Switching Waveforms** (continued)

**Figure 3. NOP, STALL, and DESELECT Cycles**<sup>[29, 30, 31]</sup>

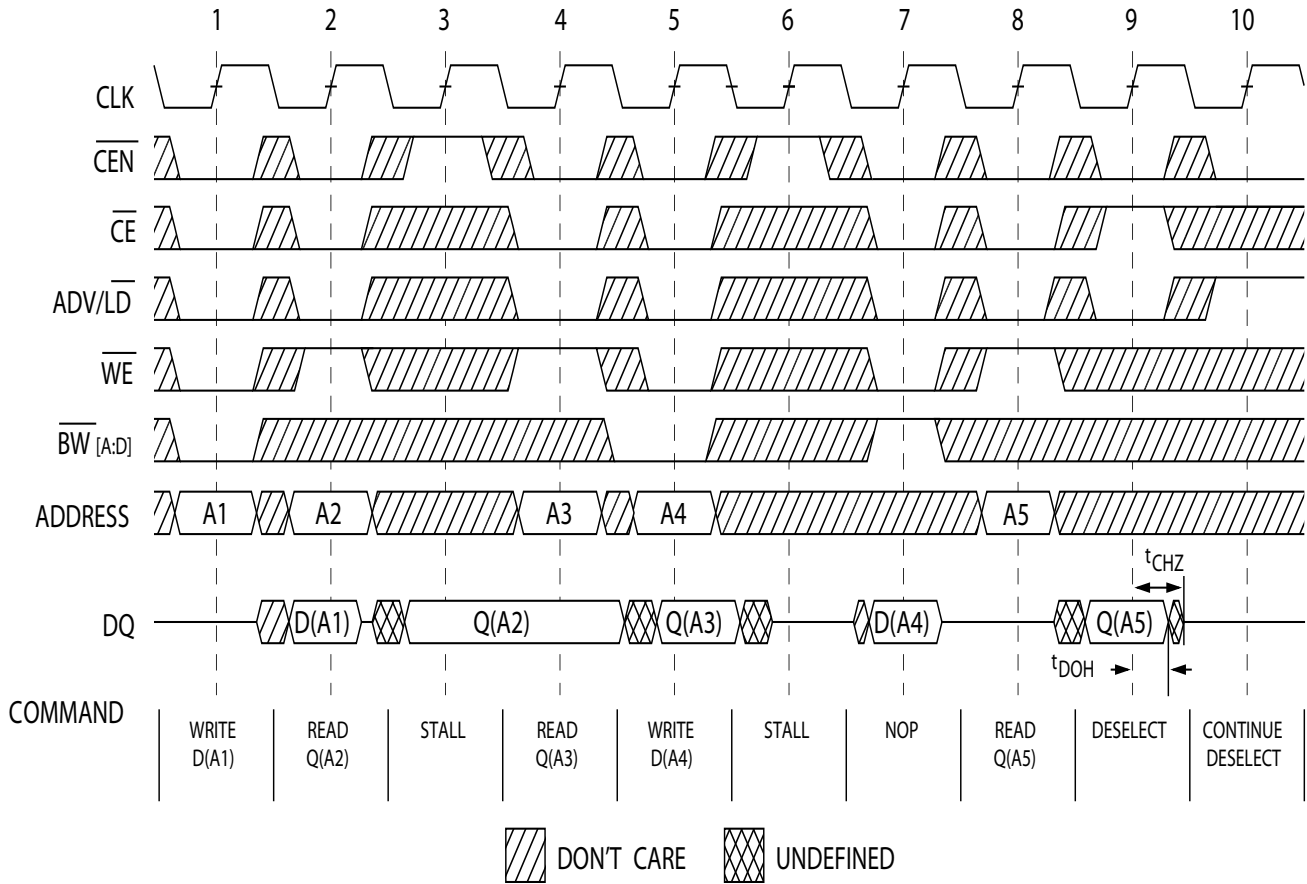

**Notes**

29. For this waveform ZZ is tied LOW.

30. When  $\overline{CE}$  is LOW,  $\overline{CE}_1$  is LOW,  $CE_2$  is HIGH and  $\overline{CE}_3$  is LOW. When  $\overline{CE}$  is HIGH,  $\overline{CE}_1$  is HIGH or  $CE_2$  is LOW or  $\overline{CE}_3$  is HIGH.

31. The IGNORE CLOCK EDGE or STALL cycle (Clock 3) illustrates  $\overline{CEN}$  being used to create a pause. A write is not performed during this cycle.

**Switching Waveforms** (continued)

**Figure 4. ZZ Mode Timing**<sup>[32, 33]</sup>

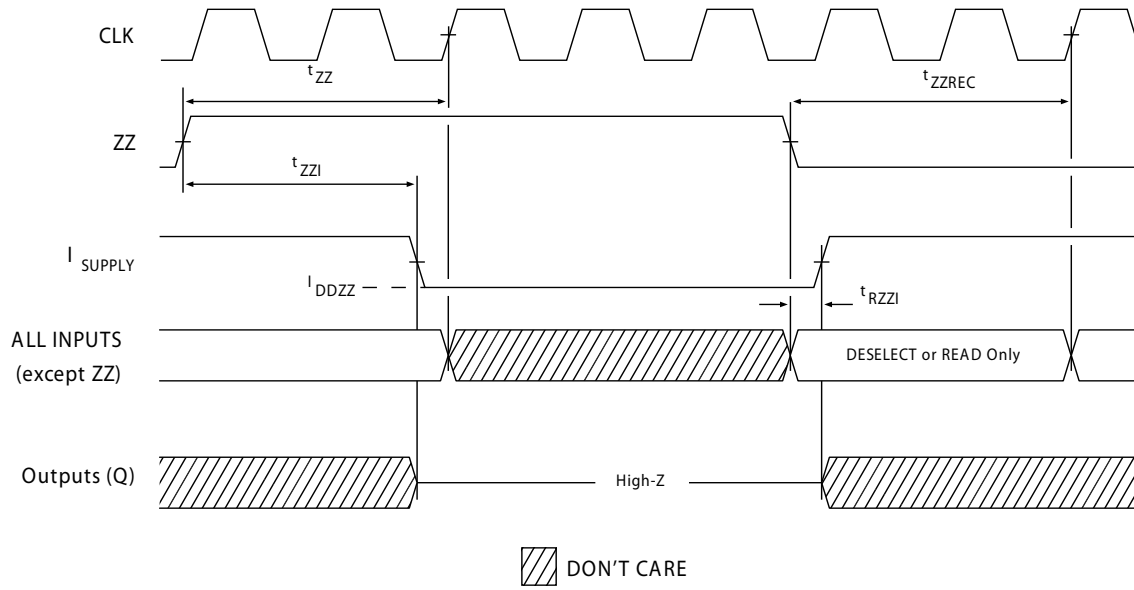

**Notes**

- 32. Device must be deselected when entering ZZ mode. See truth table for all possible signal conditions to deselect the device.
- 33. DQs are in High Z when exiting ZZ sleep mode.

## Ordering Information

Cypress offers other versions of this type of product in different configurations and features. The following table contains only the list of parts that are currently available.

For a complete listing of all options, visit the Cypress website at [www.cypress.com](http://www.cypress.com) and refer to the product summary page at <http://www.cypress.com/products>, or contact your local sales representative.

Cypress maintains a worldwide network of offices, solution centers, manufacturer's representatives and distributors. To find the office closest to you, visit us at <http://www.cypress.com/go/datasheet/offices>.

| Speed (MHz) | Ordering Code       | Package Diagram | Part and Package Type                                  | Operating Range |
|-------------|---------------------|-----------------|--|-----------------|
| 133         | CY7C1461AV33-133AXC | 51-85050        | 100-pin Thin Quad Flat Pack (14 × 20 × 1.4 mm) Pb-free | Commercial      |
|             | CY7C1463AV33-133AXC |                 |  |                 |
|             | CY7C1461AV33-133AXI | 51-85050        | 100-pin Thin Quad Flat Pack (14 × 20 × 1.4 mm) Pb-free | Industrial      |

## Ordering Code Definitions

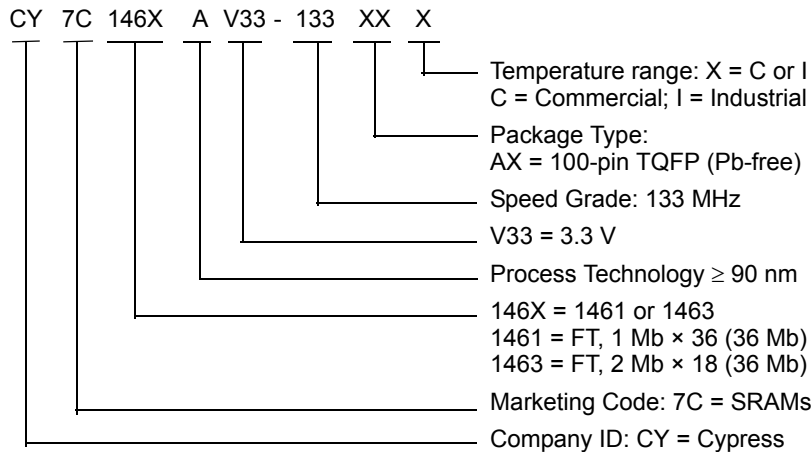

**Package Diagrams**

**Figure 5. 100-pin TQFP (14 × 20 × 1.4 mm), 51-85050**

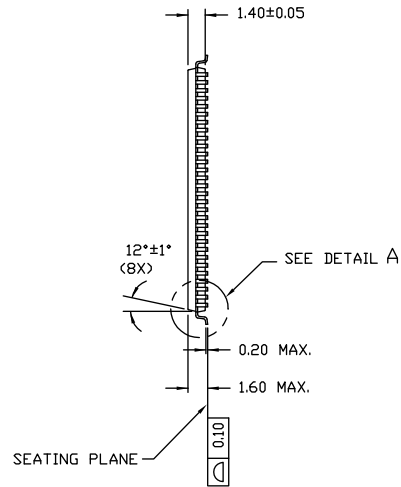
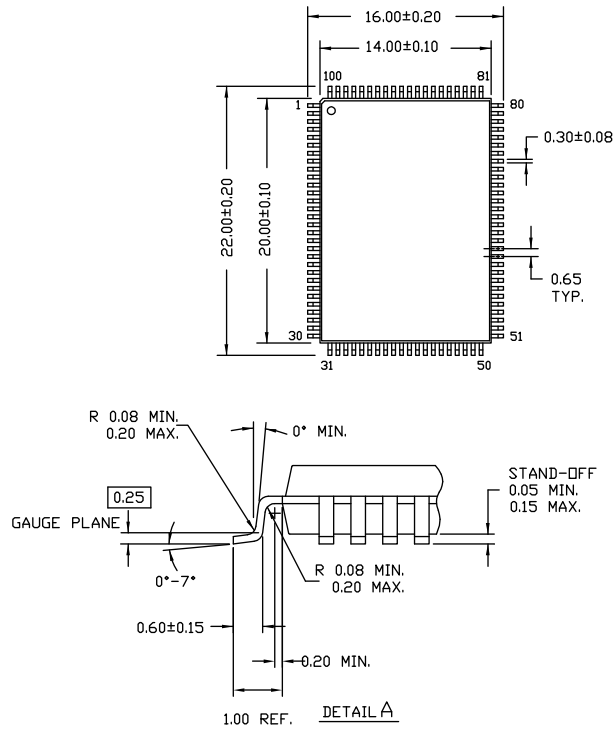

NOTE:

1. JEDEC STD REF MS-026
2. BODY LENGTH DIMENSION DOES NOT INCLUDE MOLD PROTRUSION/END FLASH  
 MOLD PROTRUSION/END FLASH SHALL NOT EXCEED 0.0098 in (0.25 mm) PER SIDE  
 BODY LENGTH DIMENSIONS ARE MAX PLASTIC BODY SIZE INCLUDING MOLD MISMATCH
3. DIMENSIONS IN MILLIMETERS

51-85050 \*D

**Package Diagrams** (continued)

**Figure 6. 165-ball FBGA (15 × 17 × 1.4 mm), 51-85165**

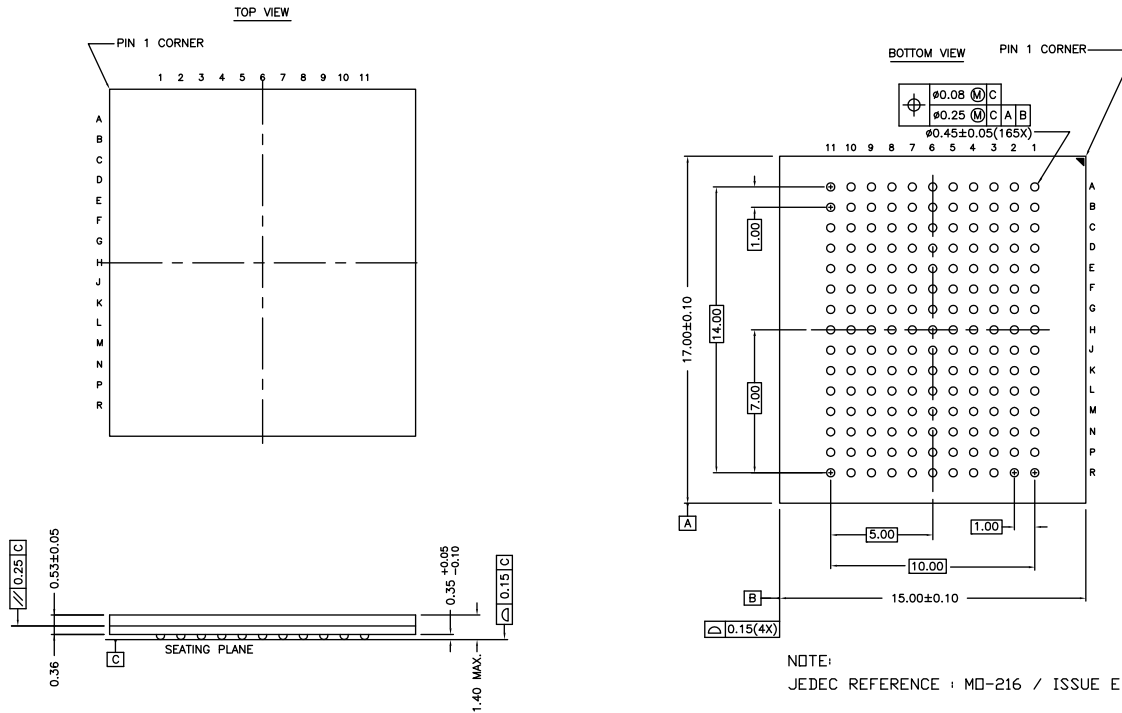

51-85165 \*B

**Package Diagrams** (continued)

**Figure 7. 209-ball FBGA (14 × 22 × 1.76 mm), 51-85167**

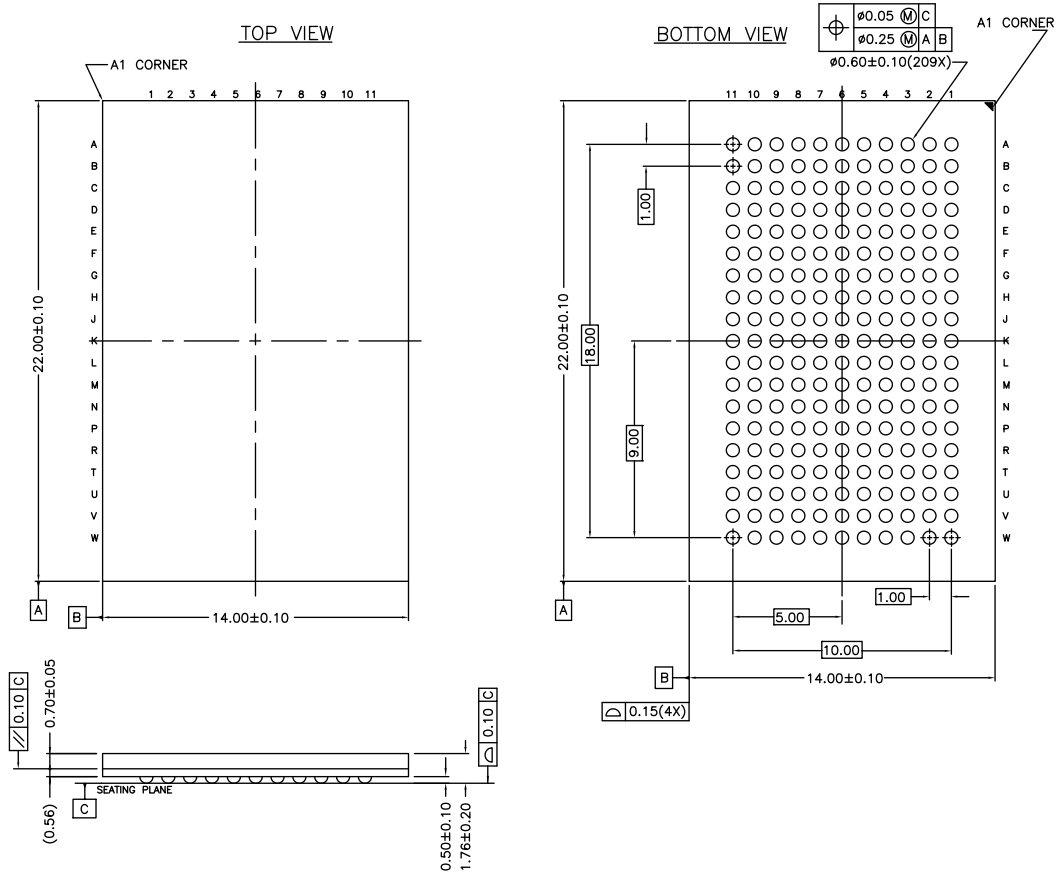

51-85167 \*A

## Document History Page

| Document Title: CY7C1461AV33/CY7C1463AV33/CY7C1465AV33 36-Mbit (1 M × 36/2 M × 18/512 K × 72) Flow-Through SRAM with NoBL™ Architecture<br>Document Number: 38-05356 |         |            |                 |   |
|--|---------|------------|-----------------|---|
| REV.   | ECN NO. | Issue Date | Orig. of Change | Description of Change   |
| **   | 254911  | See ECN    | SYT             | New data sheet<br>Part number changed from previous revision. New and old part number differ by the letter "A"  |
| *A   | 300131  | See ECN    | SYT             | Removed 150- and 117-MHz Speed Bins<br>Changed $\Theta_{JA}$ and $\Theta_{JC}$ from TBD to 25.21 and 2.58 °C/W, respectively, for TQFP package<br>Added Pb-free information for 100-pin TQFP, 165 FBGA and 209 FBGA packages<br>Added "Pb-free BG and BZ packages availability" below the Ordering Information  |
| *B   | 320813  | See ECN    | SYT             | Changed H9 pin from $V_{SSQ}$ to $V_{SS}$ on the Pin Configuration table for 209 FBGA<br>Changed the test condition from $V_{DD} = \text{Min.}$ to $V_{DD} = \text{Max}$ for $V_{OL}$ in the Electrical Characteristics table<br>Replaced the TBD's for $I_{DD}$ , $I_{SB1}$ , $I_{SB2}$ , $I_{SB3}$ and $I_{SB4}$ to their respective values<br>Replaced TBD's for $\Theta_{JA}$ and $\Theta_{JC}$ to their respective values on the Thermal Resistance table for 165 FBGA and 209 FBGA Packages<br>Changed $C_{IN}$ , $C_{CLK}$ and $C_{IO}$ to 6.5, 3 and 5.5 pF from 5, 5 and 7 pF for TQFP Package<br>Removed "Pb-free BG packages availability" comment below the Ordering Information  |
| *C   | 331551  | See ECN    | SYT             | Modified Address Expansion balls in the pinouts for 165 FBGA and 209 FBGA Packages according to JEDEC standards and updated the Pin Definitions accordingly<br>Modified $V_{OL}$ , $V_{OH}$ test conditions<br>Replaced TBD to 100 mA for $I_{DDZZ}$<br>Changed $C_{IN}$ , $C_{CLK}$ and $C_{IO}$ to 7, 7 and 6 pF from 5, 5 and 7 pF for 165 FBGA Package<br>Added Industrial Temperature Grade<br>Changed $I_{SB2}$ and $I_{SB4}$ from 100 and 110 mA to 120 and 135 mA respectively<br>Updated the Ordering Information by shading and unshading MPNs according to availability  |
| *D   | 417547  | See ECN    | R XU            | Converted from Preliminary to Final<br>Changed address of Cypress Semiconductor Corporation on Page# 1 from "3901 North First Street" to "198 Champion Court"<br>Changed $I_X$ current value in MODE from -5 & 30 $\mu\text{A}$ to -30 & 5 $\mu\text{A}$ respectively and also Changed $I_X$ current value in ZZ from -30 & 5 $\mu\text{A}$ to -5 & 30 $\mu\text{A}$ respectively on page# 20<br>Modified test condition from $V_{IH} \leq V_{DD}$ to $V_{IH} < V_{DD}$<br>Modified "Input Load" to "Input Leakage Current except ZZ and MODE" in the Electrical Characteristics Table<br>Replaced Package Name column with Package Diagram in the Ordering Information table<br>Replaced Package Diagram of 51-85050 from *A to *B<br>Updated the Ordering Information |



**Document History Page** (continued)

| Document Title: CY7C1461AV33/CY7C1463AV33/CY7C1465AV33 36-Mbit (1 M × 36/2 M × 18/512 K × 72) Flow-Through SRAM with NoBL™ Architecture<br>Document Number: 38-05356 |         |            |                 |   |
|--|---------|------------|-----------------|---|
| REV.   | ECN NO. | Issue Date | Orig. of Change | Description of Change   |
| *E   | 473650  | See ECN    | VKN             | Added the Maximum Rating for Supply Voltage on V <sub>DDQ</sub> Relative to GND. Changed t <sub>TH</sub> , t <sub>TL</sub> from 25 ns to 20 ns and t <sub>TDOV</sub> from 5 ns to 10 ns in TAP AC Switching Characteristics table.<br>Updated the Ordering Information table. |
| *F   | 1274733 | See ECN    | VKN/AESA        | Corrected typo in the “NOP, STALL and DESELECT Cycles” waveform   |
| *G   | 2499107 | See ECN    | VKN/PYRS        | Corrected typo in the CY7C1465AV33 's Logic Block diagram   |
| *H   | 2897278 | 03/22/2010 | NJY             | Removed obsolete part numbers from Ordering Information table and updated package diagrams.   |
| *I   | 3208774 | 03/29/2011 | NJY             | Updated <a href="#">Ordering Information</a> and added <a href="#">Ordering Code Definitions</a> .<br>Updated <a href="#">Package Diagrams</a> .<br>Updated in new template.  |

## Sales, Solutions, and Legal Information

### Worldwide Sales and Design Support

Cypress maintains a worldwide network of offices, solution centers, manufacturer's representatives, and distributors. To find the office closest to you, visit us at [Cypress Locations](#).

### Products

|                          |  |
|--------------------------|--|
| Automotive               | <a href="http://cypress.com/go/automotive">cypress.com/go/automotive</a>   |
| Clocks & Buffers         | <a href="http://cypress.com/go/clocks">cypress.com/go/clocks</a>   |
| Interface                | <a href="http://cypress.com/go/interface">cypress.com/go/interface</a>   |
| Lighting & Power Control | <a href="http://cypress.com/go/powerpsoc">cypress.com/go/powerpsoc</a><br><a href="http://cypress.com/go/plc">cypress.com/go/plc</a> |
| Memory                   | <a href="http://cypress.com/go/memory">cypress.com/go/memory</a>   |
| Optical & Image Sensing  | <a href="http://cypress.com/go/image">cypress.com/go/image</a>   |
| PSoC                     | <a href="http://cypress.com/go/psoc">cypress.com/go/psoc</a>   |
| Touch Sensing            | <a href="http://cypress.com/go/touch">cypress.com/go/touch</a>   |
| USB Controllers          | <a href="http://cypress.com/go/USB">cypress.com/go/USB</a>   |
| Wireless/RF              | <a href="http://cypress.com/go/wireless">cypress.com/go/wireless</a>   |

### PSoC Solutions

[psoc.cypress.com/solutions](http://psoc.cypress.com/solutions)  
PSoC 1 | PSoC 3 | PSoC 5

---

© Cypress Semiconductor Corporation, 2004-2011. The information contained herein is subject to change without notice. Cypress Semiconductor Corporation assumes no responsibility for the use of any circuitry other than circuitry embodied in a Cypress product. Nor does it convey or imply any license under patent or other rights. Cypress products are not warranted nor intended to be used for medical, life support, life saving, critical control or safety applications, unless pursuant to an express written agreement with Cypress. Furthermore, Cypress does not authorize its products for use as critical components in life-support systems where a malfunction or failure may reasonably be expected to result in significant injury to the user. The inclusion of Cypress products in life-support systems application implies that the manufacturer assumes all risk of such use and in doing so indemnifies Cypress against all charges.

Any Source Code (software and/or firmware) is owned by Cypress Semiconductor Corporation (Cypress) and is protected by and subject to worldwide patent protection (United States and foreign), United States copyright laws and international treaty provisions. Cypress hereby grants to licensee a personal, non-exclusive, non-transferable license to copy, use, modify, create derivative works of, and compile the Cypress Source Code and derivative works for the sole purpose of creating custom software and or firmware in support of licensee product to be used only in conjunction with a Cypress integrated circuit as specified in the applicable agreement. Any reproduction, modification, translation, compilation, or representation of this Source Code except as specified above is prohibited without the express written permission of Cypress.

Disclaimer: CYPRESS MAKES NO WARRANTY OF ANY KIND, EXPRESS OR IMPLIED, WITH REGARD TO THIS MATERIAL, INCLUDING, BUT NOT LIMITED TO, THE IMPLIED WARRANTIES OF MERCHANTABILITY AND FITNESS FOR A PARTICULAR PURPOSE. Cypress reserves the right to make changes without further notice to the materials described herein. Cypress does not assume any liability arising out of the application or use of any product or circuit described herein. Cypress does not authorize its products for use as critical components in life-support systems where a malfunction or failure may reasonably be expected to result in significant injury to the user. The inclusion of Cypress' product in a life-support systems application implies that the manufacturer assumes all risk of such use and in doing so indemnifies Cypress against all charges.

Use may be limited by and subject to the applicable Cypress software license agreement.