

TOSHIBA CMOS DIGITAL INTEGRATED CIRCUIT SILICON MONOLITHIC

TC74VHCT540AF, TC74VHCT540AFW, TC74VHCT540AFT
TC74VHCT541AF, TC74VHCT541AFW, TC74VHCT541AFT

OCTAL BUS BUFFER

TC74VHCT540AF / AFW / AFT INVERTED, 3 - STATE OUTPUTS

TC74VHCT541AF / AFW / AFT NON - INVERTED, 3 - STATE OUTPUTS

(Note) The JEDEC SOP (FW) is not available in Japan.

The TC74VHCT540A and 541A are advanced high speed CMOS OCTAL BUS BUFFERS fabricated with silicon gate C²MOS technology. They achieve the high speed operation similar to equivalent Bipolar Schottky TTL while maintaining the CMOS low power dissipation.

The TC74VHCT540A is an inverting type and, the TC74VHCT541A is a non-inverting type.

When either $\bar{G}1$ or $\bar{G}2$ are high, the terminal outputs are in the high-impedance state.

The input voltage are compatible with TTL output voltage.

These devices may be used as a level converter for interfacing 3.3V to 5V system.

Input protection and output circuit ensure that 0 to 5.5V can be applied to the input and output*1 pins without regard to the supply voltage. These structure prevents device destruction due to mismatched supply and input/output voltages such as battery back up, hot board insertion, etc.

*1: output in off-state

FEATURES:

- High Speed..... $t_{pd} = 5.4ns$ (typ.) at $V_{CC} = 5V$
- Low Power Dissipation..... $I_{CC} = 4\mu A$ (Max.) at $T_a = 25^\circ C$
- Compatible with TTL outputs ... $V_{IL} = 0.8 V$ (Max.)
 $V_{IH} = 2.0 V$ (Min.)
- Power Down Protection is provided on all inputs and outputs
- Balanced Propagation Delays..... $t_{pLH} \approx t_{pHL}$
- Low Noise $V_{OLP} = 1.6V$ (Max.)
- Pin and Function Compatible with the 74 series (74AC/HC / F / ALS / LS etc.) 540 / 541 type.

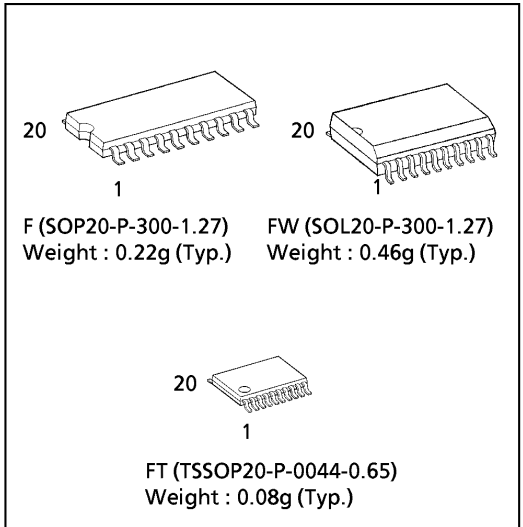

TRUTH TABLE

INPUTS			OUTPUTS	
$\bar{G}1$	$\bar{G}2$	A _n	Y _n *	\bar{Y}_n *
H	X	X	Z	Z
X	H	X	Z	Z
L	L	H	H	L
L	L	L	L	H

X : Don't Care
 Z : High Impedance
 * : Y_n VHCT541A
 \bar{Y}_n VHCT540A

PIN ASSIGNMENT

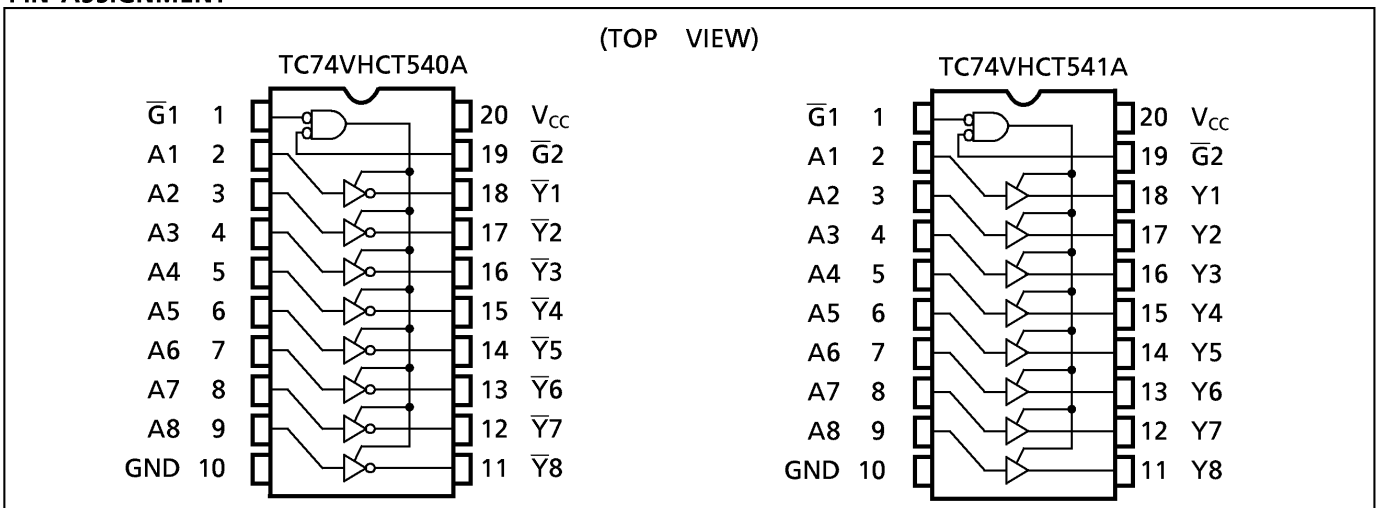

IEC LOGIC SYMBOL

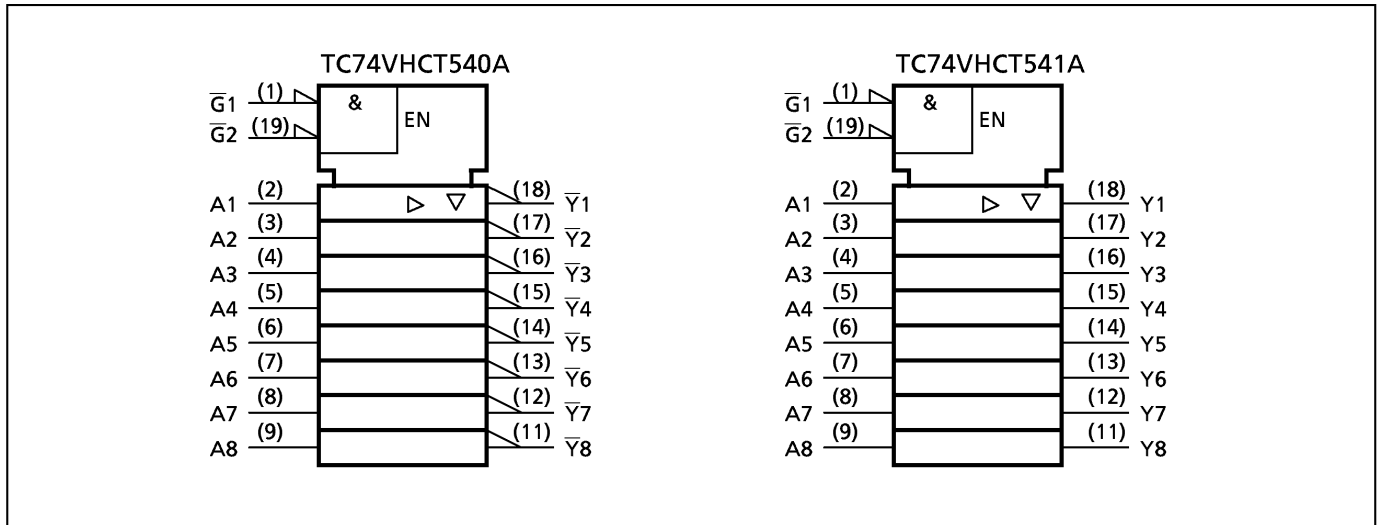

ABSOLUTE MAXIMUM RATINGS

PARAMETER	SYMBOL	VALUE	UNIT
Supply Voltage Range	V_{CC}	-0.5~7.0	V
DC Input Voltage	V_{IN}	-0.5~7.0	V
DC Output Voltage	V_{OUT}	-0.5~7.0 (Note 1)	V
		-0.5~ $V_{CC} + 0.5$ (Note 2)	
Input Diode Current	I_{IK}	-20	mA
Output Diode Current	I_{OK}	±20 (Note 3)	mA
DC Output Current	I_{OUT}	±25	mA
DC Vcc/Ground Current	I_{CC}	±75	mA
Power Dissipation	P_D	180	mW
Storage Temperature	T_{stg}	-65~150	°C

(Note 1) Output in Off-State

(Note 2) High or Low State. I_{OUT} absolute maximum rating must be observed.

(Note 3) $V_{OUT} < GND$, $V_{OUT} > V_{CC}$

RECOMMENDED OPERATING CONDITIONS

PARAMETER	SYMBOL	VALUE	UNIT
Supply Voltage	V_{CC}	4.5~5.5	V
Input Voltage	V_{IN}	0~5.5	V
Output Voltage	V_{OUT}	0~5.5 (Note 4)	V
		0~ V_{CC} (Note 5)	
Operating Temperature	T_{opr}	-40~85	°C
Input Rise and Fall Time	dt/dV	0~20	ns/V

(Note 4) Output in Off-State

(Note 5) High or Low State

DC ELECTRICAL CHARACTERISTICS

PARAMETER	SYMBOL	CONDITON		V _{CC} (V)	Ta = 25°C			Ta = -40~85°C		UNIT
					MIN.	TYP.	MAX.	MIN.	MAX.	
High - Level Input Voltage	V _{IH}			4.5~5.5	2.0	—	—	2.0	—	V
Low - Level Input Voltage	V _{IL}			4.5~5.5	—	—	0.8	—	0.8	V
High - Level Output Voltage	V _{OH}	V _{IN} = V _{IH} or V _{IL}	I _{OH} = -50μA	4.5	4.40	4.50	—	4.40	—	V
			I _{OH} = -8mA	4.5	3.94	—	—	3.80	—	
Low - Level Output Voltage	V _{OL}	V _{IN} = V _{IH} or V _{IL}	I _{OL} = 50μA	4.5	—	0.0	0.10	—	0.10	V
			I _{OL} = 8mA	4.5	—	—	0.36	—	0.44	
3 - State Output Off - State Current	I _{OZ}	V _{IN} = V _{IH} or V _{IL} V _{OUT} = V _{CC} or GND		5.5	—	—	±0.25	—	±2.50	μA
Input Leakage Current	I _{IN}	V _{IN} = 5.5V or GND		0~5.5	—	—	±0.1	—	±1.0	
Quiescent Supply Current	I _{CC}	V _{IN} = V _{CC} or GND		5.5	—	—	4.0	—	40.0	
	I _{CCT}	PER INPUT : V _{IN} = 3.4V OTHER INPUT : V _{CC} or GND		5.5	—	—	1.35	—	1.50	mA
Output Leakage Current	I _{OPD}	V _{OUT} = 5.5V		0	—	—	+0.5	—	+5.0	μA

AC ELECTRICAL CHARACTERISTICS (Input t_r = t_f = 3ns)

PARAMETER	SYMBOL	TEST CONDITION			Ta = 25°C			Ta = -40~85°C		UNIT
		V _{CC} (V)	C _L (pF)		MIN.	TYP.	MAX.	MIN.	MAX.	
Propagation Delay Time (TC74VHCT540A)	t _{pLH}	5.0 ± 0.5	15	—	5.4	7.4	1.0	8.5	ns	
	t _{pHL}		50	—	5.9	8.4	1.0	9.5		
Propagation Delay Time (TC74VHCT541A)	t _{pLH}	5.0 ± 0.5	15	—	5.0	6.9	1.0	8.0		
	t _{pHL}		50	—	5.5	7.9	1.0	9.0		
3-State Output Enable Time	t _{pZL}	R _L = 1kΩ	5.0 ± 0.5	15	—	8.3	11.3	1.0		13.0
	t _{pZH}			50	—	8.8	12.3	1.0		14.0
3-State Output Disable Time	t _{pLZ}	R _L = 1kΩ	5.0 ± 0.5	50	—	9.4	11.9	1.0		13.5
	t _{pHZ}									
Output to Output Skew	t _{osLH} t _{osHL}	(Note 6)	5.0 ± 0.5	50	—	—	1.0	—	1.0	
Input Capacitance	C _{IN}				—	4	10	—	10	pF
Output Capacitance	C _{OUT}				—	9	—	—	—	
Power Dissipation Capacitance	C _{PD}	(Note 7)			—	19	—	—	—	

(Note 6) Parameter guaranteed by design. t_{osLH} = |t_{pLHm} - t_{pLHn}|, t_{osHL} = |t_{pHLm} - t_{pHLn}|

(Note 7) C_{PD} is defined as the value of the internal equivalent capacitance which is calculated from the operating current consumption without load.

Average operating current can be obtained by the equation :

$$I_{CC(opr.)} = C_{PD} \cdot V_{CC} \cdot f_{IN} + I_{CC} / 8 \text{ (per bit)}$$

NOISE CHARACTERISTICS (Input $t_r = t_f = 3ns$)

PARAMETER	SYMBOL	TEST CONDITION	Ta = 25°C		UNIT	
			V _{CC} (V)	TYP. / LIMIT		
Quiet Output Maximum Dynamic V _{OL}	V _{OLP}	C _L = 50pF	5.0	1.1 (1.2)	1.5 (1.6)	V
Quiet Output Minimum Dynamic V _{OL}	V _{OLV}	C _L = 50pF	5.0	-1.1 (-1.2)	-1.5 (-1.6)	V
Minimum High Level Dynamic Input Voltage	V _{IHD}	C _L = 50pF	5.0	—	2.0	V
Maximum Low Level Dynamic Input Voltage	V _{ILD}	C _L = 50pF	5.0	—	0.8	V

(Note) The value in () only applies to JEDEC SOP (FW) devices.

SOP 20PIN (200mil BODY) PACKAGE DIMENSIONS (SOP20-P-300-1.27)

Unit in mm

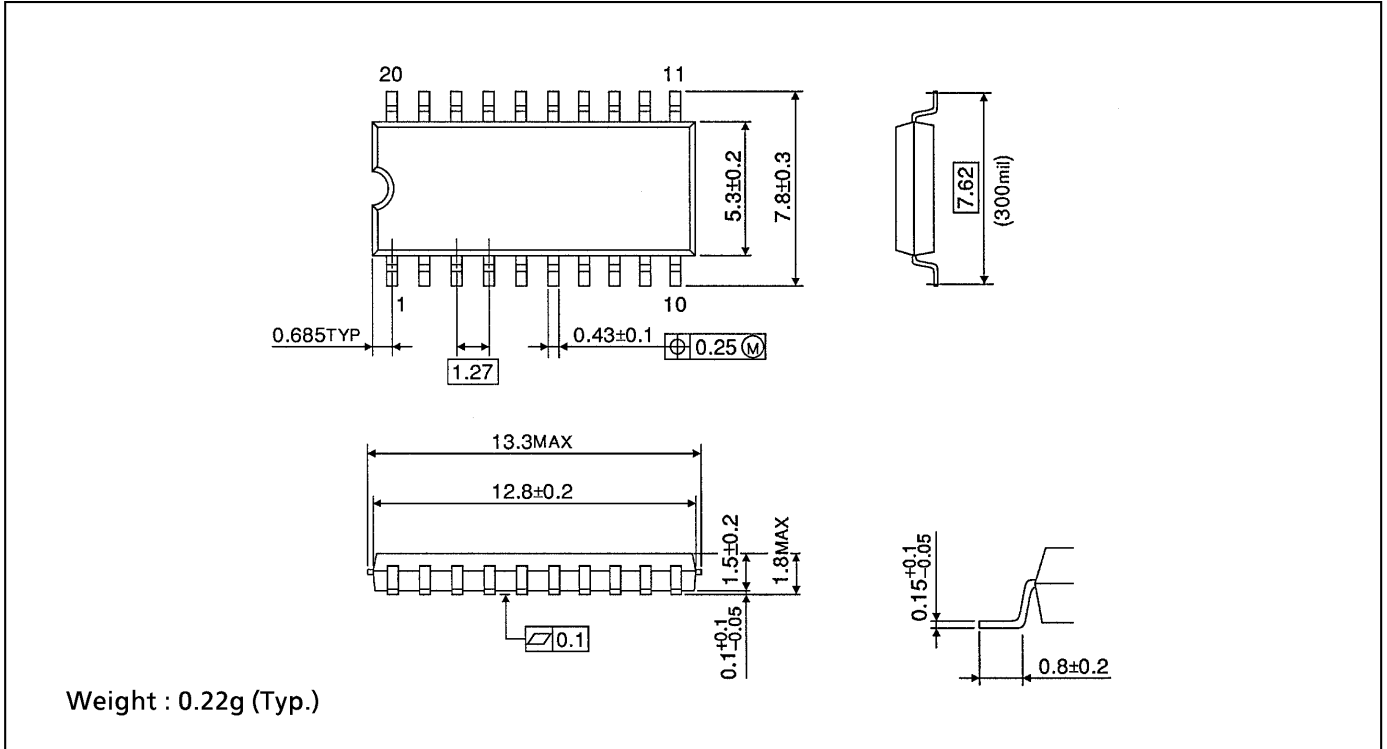

SOP 20PIN (300mil BODY) PACKAGE DIMENSIONS (SOL20-P-300-1.27)

Unit in mm

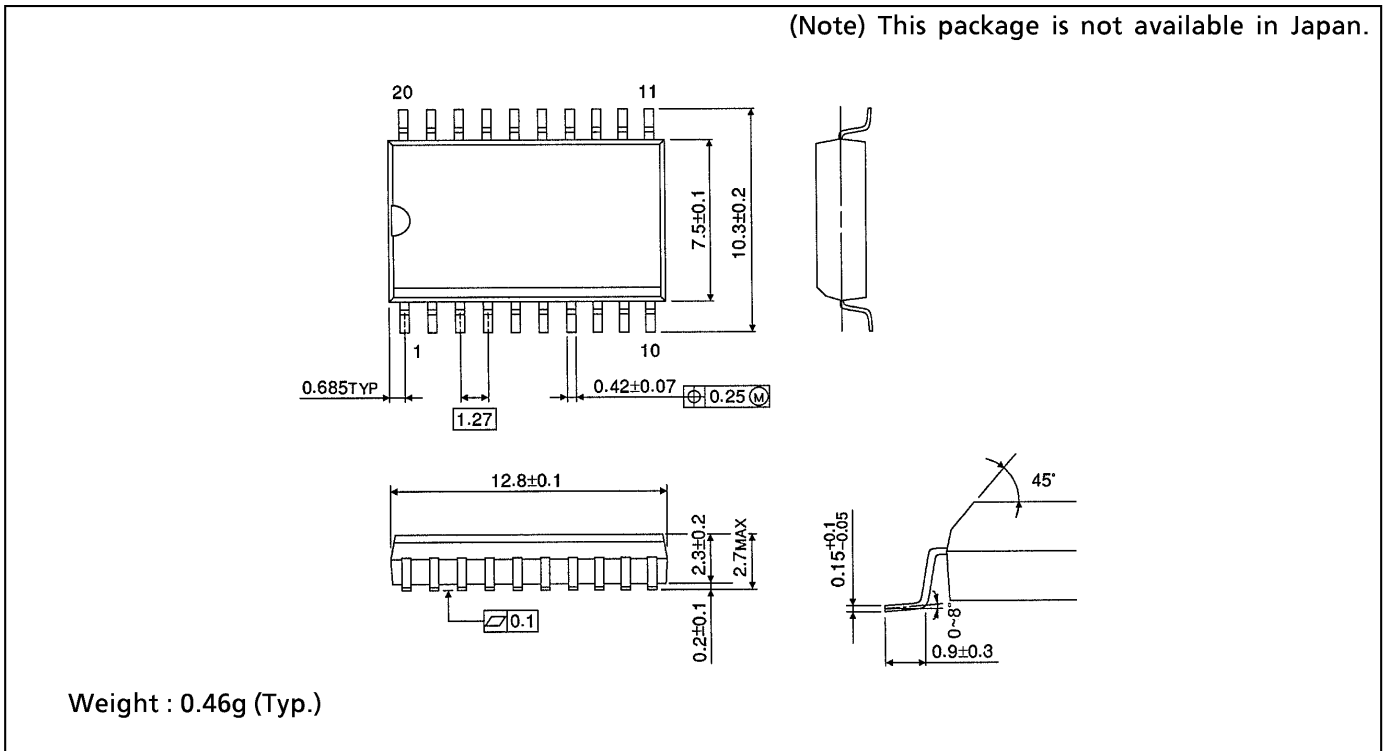

TSSOP 20PIN PACKAGE DIMENSIONS (TSSOP20-P-0044-0.65)

Unit in mm

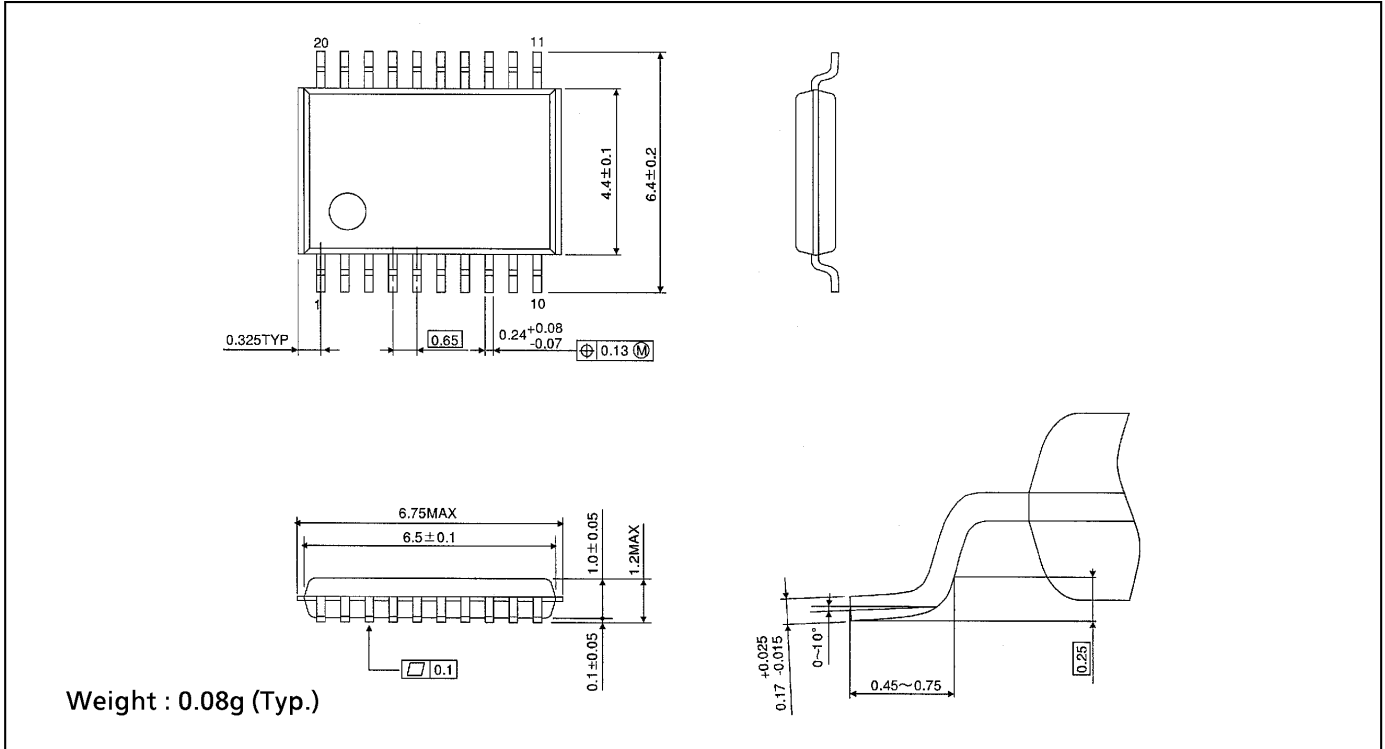

RESTRICTIONS ON PRODUCT USE

000707EBA

- TOSHIBA is continually working to improve the quality and reliability of its products. Nevertheless, semiconductor devices in general can malfunction or fail due to their inherent electrical sensitivity and vulnerability to physical stress. It is the responsibility of the buyer, when utilizing TOSHIBA products, to comply with the standards of safety in making a safe design for the entire system, and to avoid situations in which a malfunction or failure of such TOSHIBA products could cause loss of human life, bodily injury or damage to property. In developing your designs, please ensure that TOSHIBA products are used within specified operating ranges as set forth in the most recent TOSHIBA products specifications. Also, please keep in mind the precautions and conditions set forth in the "Handling Guide for Semiconductor Devices," or "TOSHIBA Semiconductor Reliability Handbook" etc..
- The TOSHIBA products listed in this document are intended for usage in general electronics applications (computer, personal equipment, office equipment, measuring equipment, industrial robotics, domestic appliances, etc.). These TOSHIBA products are neither intended nor warranted for usage in equipment that requires extraordinarily high quality and/or reliability or a malfunction or failure of which may cause loss of human life or bodily injury ("Unintended Usage"). Unintended Usage include atomic energy control instruments, airplane or spaceship instruments, transportation instruments, traffic signal instruments, combustion control instruments, medical instruments, all types of safety devices, etc.. Unintended Usage of TOSHIBA products listed in this document shall be made at the customer's own risk.
- The products described in this document are subject to the foreign exchange and foreign trade laws.
- The information contained herein is presented only as a guide for the applications of our products. No responsibility is assumed by TOSHIBA CORPORATION for any infringements of intellectual property or other rights of the third parties which may result from its use. No license is granted by implication or otherwise under any intellectual property or other rights of TOSHIBA CORPORATION or others.
- The information contained herein is subject to change without notice.