

# 3A, 30V, 340KHz Synchronous Step-Down Converter

## DESCRIPTION

The EUP3484 is a synchronous current mode buck regulator capable of driving 3A continuous load current with excellent line and load regulation. The EUP3484 can operate with an input range 4.5V to 30V and the output can be externally set from 0.925V to 20V with a resistor divider.

Fault condition protection includes cycle-by-cycle current limiting and thermal shutdown. In shutdown mode the regulator draws 1 $\mu$ A of supply current. Programmable soft-start minimizes the inrush supply current and the output overshoot at initial startup.

The EUP3484 require a minimum number of external components.

## FEATURES

- 3A Output Current
- 220ns Minimum On Time
- 35V Input Surge Protection
- Integrated 160m $\Omega$ /110m $\Omega$  DMOS Switches
- 4.5V to 30V Input Operating Range
- Output Adjustable from 0.925V to 20V
- Up to 95% Efficiency
- 1 $\mu$ A Shutdown Current
- Fixed 340KHz Frequency
- Programmable Soft-Start
- Thermal Shutdown and Overcurrent Protection
- Input Supply Overvoltage and Undervoltage Lockout
- Available in SOP-8 (EP) Package
- RoHS Compliant and 100% Lead(Pb)-Free Halogen-Free

## APPLICATIONS

- Distributed Power Systems
- Networking Systems
- PC Monitors
- Portable Electronics

## Typical Application Circuit

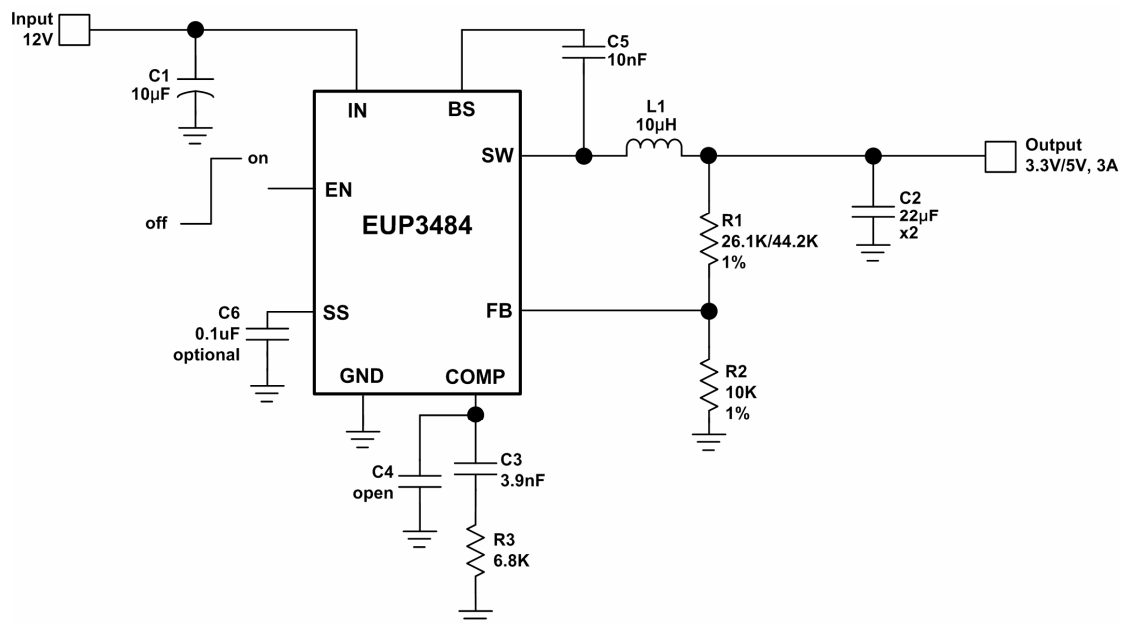

Figure 1. 12V to 3.3V/5V Application Circuit