



GM23V16000A

2M × 8/1M × 16BIT
CMOS MASK ROM

Description

The GM23V16000A high performance read only memory is organized either as 2,097,152 × 8 bit (Byte Mode) or as 1,048,576 × 16 bit (Word Mode) followed by BHE mode select. The GM23V16000A offers automatic power down controlled by the mask programmed CE or \overline{CE} input. This device operates with a 3V or 3.3V single power supply and all input and output are TTL compatible. The large size of 16M bit memory density is ideal for character generator, data or program memory in micro processor application.

Features

- Switchable organization
 - Byte mode: 2M × 8 bit
 - Word mode: 1M × 16bit
- Supply voltage: Single +3V or +3.3V
- Access Time: 3.0V-200ns/250ns/300ns (Max)
3.3V-150ns/200ns/250ns (Max)
- Operating current:
 - 25mA (Max) at $V_{CC}=3.0V \pm 0.3V$
 - 30mA (Max) at $V_{CC}=3.3V \pm 0.3V$
- Standby current: 50 μ A (Max)
- TTL-compatible inputs and outputs
- Programmable Chip Enable and Out Enable
- 3-state outputs for wired-OR expansion
- Fully static operation
- Package:

GM23V16000A: 42 pin Plastic DIP (600mil)

GM23V16000AFW: 44 pin Plastic SOP (600mil)

Pin Description

Pin	Function
A0 ~ A19	Address Input
O0 ~ O14	Data Output
O15/A-1	Output Data 15 (Word Mode) LSB Address (Byte Mode)
BHE	WORD/BYTE Selection
CE/ \overline{CE} *	Chip Enable Input
OE/ \overline{OE} *	Output Enable Input
V _{CC}	Power (+3V or 3.3V)
V _{SS}	GND
N.C	No Connection

* User Selectable Polarity

Pin Configuration

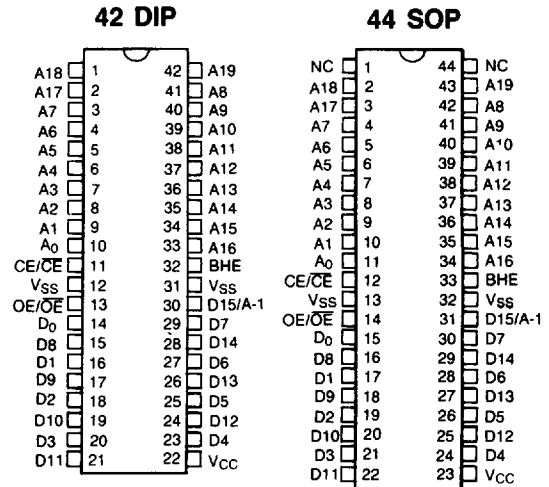

(Top View)

(Top View)

Block Diagram

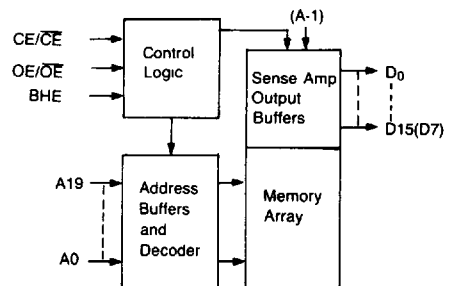

Absolute Maximum Ratings*

Symbol	Parameter	Rating	Unit
T _A	Ambient Temperature	-10 ~ +85	°C
T _{STG}	Storage Temperature	-65 ~ 150	°C
V _{CC}	Supply Voltage to Ground Potential	-0.5 ~ 7.0	V
V _{OUT}	Output Voltage	-0.5 ~ V _{CC} + 0.5	V
V _{IN}	Input Voltage	-0.5 ~ V _{CC} + 0.5	V

*Stresses above those listed under "Absolute Maximum Ratings" may cause permanent damage to the device. These are stress ratings only. Function operating of this device at these or any other conditions above those indicated in the operational sections of this specification is not implied and exposure to absolute maximum rating conditions for extended periods may affect device reliability.

Recommended DC Operating Condition (T_A = 0 ~ 70°C)

Symbol	Parameter	Min	Typ	Max	Unit
V _{CC}	Supply Voltage	2.7	3.0/3.3	3.6	V
V _{SS}	Supply Voltage	0	0	0	V
V _{IH}	Input High Voltage	2.2	—	V _{CC} + 0.3	V
V _{IL}	Input Low Voltage	-0.3	—	0.8	V

DC Electrical Characteristics

Symbol	Parameter	Condition	Min	Typ	Max	Unit
V _{OH}	Output High Voltage	I _{OH} = -1mA	2.4			V
V _{OL}	Output Low Voltage	I _{OL} = 2.1mA			0.4	V
I _{I(L)}	Input Leakage Current	V _{IN} = 0V to V _{CC}			±10	μA
I _{O(L)}	Output Leakage Current	V _{OUT} = 0V to V _{CC}			±10	μA
I _{CC}	Operating Supply Current	V _{CC} = 3.0V ± 0.3	$\overline{CE} = V_{IL}, CE = V_{IH}$		25	mA
		V _{CC} = 3.3V ± 0.3			30	mA
I _{SB1}	Standby Current (TTL)	$\overline{CE} = V_{IH}$, all Output Open			1	mA
I _{SB2}	Standby Current (CMOS)	$\overline{CE} = V_{CC}$, ALL Output Open			50	μA

Capacitance (T_A = 25°C, f = 1.0 MHz)

Symbol	Parameter	Condition	Min	Max	Unit
C _I	Input Capacitance	V _{IN} = 0V		10	pF
C _O	Output Capacitance	V _{OUT} = 0V		10	pF

Mode Selection

Mode	CE/ $\overline{\text{CE}}$	OE/ $\overline{\text{OE}}$	BHE	00 ~ 07	08 ~ 014	015/A-1	Power
Standby	L/H	X	X	High Z		High Z	Standby
16 Bit Operating	H/L	H/L	H	Data Out			Active
8 Bit Operating			L	Data Out (Lower 8 Bit)	High Z	L	
				Data Out (Upper 8 Bit)		H	
Output Disable	L/H	X	X	High Z		X	

AC Operating Characteristics ($V_{CC}=3.0V \pm 0.3$, $T_A=0 \sim 70^\circ\text{C}$)

Symbol	Parameter	GM23V16000A-20		GM23V16000A-25		GM23V16000A-30		Unit
		Min	Max	Min	Max	Min	Max	
t_{RC}	Read Cycle Time	200		250		300		ns
t_{ACE}	Chip Enable Access Time		200		250		300	ns
t_{AA}	Address Access Time		200		250		300	ns
t_{AOE}	Output Enable Access Time		90		110		130	ns
t_{OH}	Output Hold From Address Change	10		10		10		ns
t_{OHZ} t_{CHZ}	Output or Chip Disable to Output High-Z		40		50		60	ns
t_{OLZ} t_{CLZ}	Output or Chip Enable to Output Low-Z	10		10		10		ns

AC Operating Characteristics ($V_{CC}=3.3V \pm 0.3$, $T_A=0 \sim 70^\circ\text{C}$)

Symbol	Parameter	GM23V16000A-15		GM23V16000A-20		GM23V16000A-25		Unit
		Min	Max	Min	Max	Min	Max	
t_{RC}	Read Cycle Time	150		200		250		ns
t_{ACE}	Chip Enable Access Time		150		200		250	ns
t_{AA}	Address Access Time		150		200		250	ns
t_{OE}	Output Enable Access Time		70		90		110	ns
t_{OH}	Output Hold From Address Change	10		10		10		ns
t_{OHZ} t_{CHZ}	Output or Chip Disable to Output High-Z		30		40		50	ns
t_{OLZ} t_{CLZ}	Output or Chip Enable to Output Low-Z	10		10		10		ns

AC Test Condition

Input Pulse Level	0.4V to 2.4V
Input Rise and Fall Time	10ns
Input and Output Timing Level	1.5V
Output Load	See Fig. 1

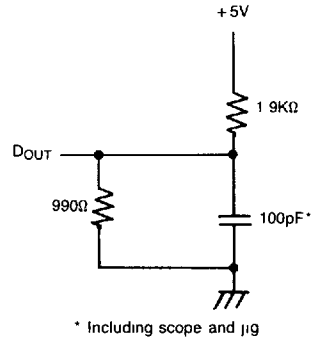
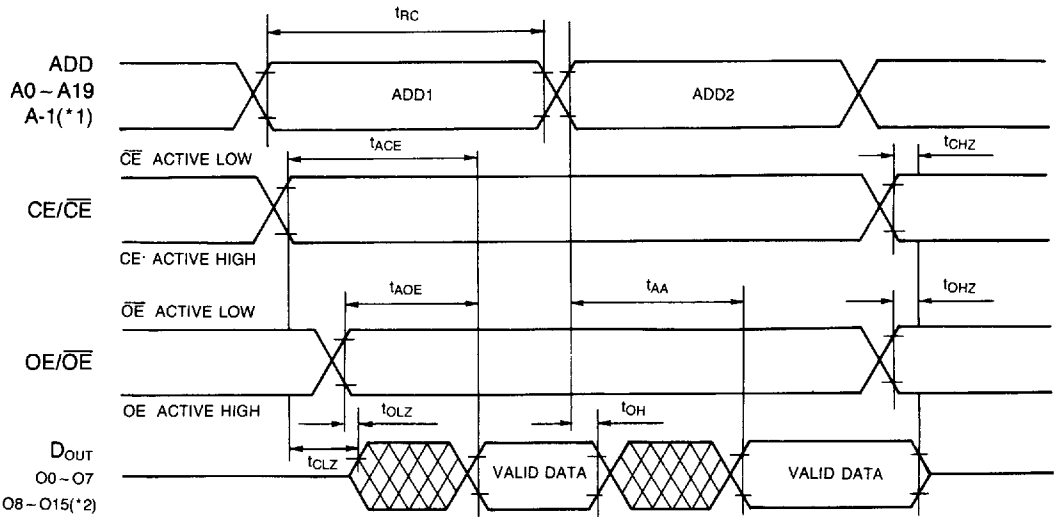

Fig. 1 Output Load Circuit

TIMING WAVEFORMS

Word Mode (BHE = V_{IH})/Byte Mode (BHE = V_{IL})



(*1) Byte Mode only. A-1 is Least Significant Bit Address. (BHE = V_{IL})

(*2) Word Mode only. (BHE = V_{IH})

Package Dimension

42 DIP

Unit Inches (mm)

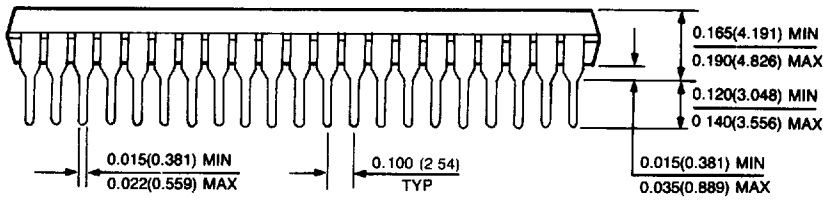
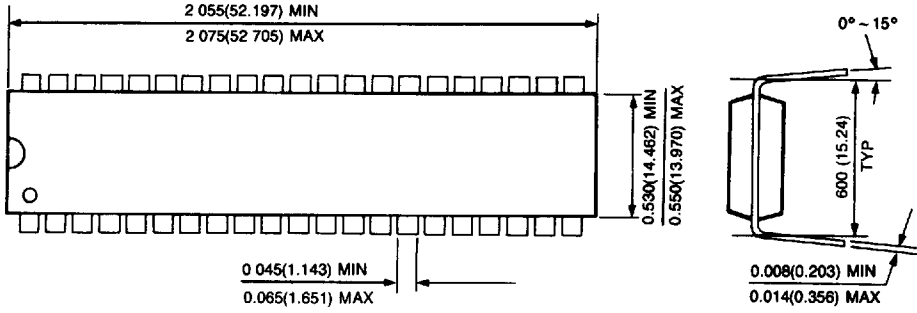

44 SOP

